

September 2007

 No. OCS08
 REVISED EDITION-A

TECHNICAL DATA BOOK **R410A**

<Indoor unit>

[Model names]

INVERTER

PLA-RP-BA
PEAD-RP-EA
PEAD-RP-EA2
PEAD-RP-GA
PEA-RP-GA
PKA-RP-GAL
PKA-RP-FAL
PKA-RP-FAL2
PCA-RP-GA
PCA-RP-GA2
PCA-RP-HA
PSA-RP-GA

Revision:

- PUAZ-P.YHA and PEA-RP-GA are added in REVISED EDITION-A.
- Some descriptions have been modified.

- Please void OCS08.

<Outdoor unit>

[Model names]

PUHZ-P100/125/140VHA2
PUHZ-P200/250YHA

CONTENTS

1. REFERENCE SERVICE MANUAL.....	2
2. SPECIFICATIONS	3
3. OUTLINES AND DIMENSIONS.....	12
4. WIRING DIAGRAM.....	34
5. REFRIGERANT SYSTEM DIAGRAM	46
6. PERFORMANCE CURVES	50
7. CORRECTION FACTORS.....	52
8. APPLICABLE EXTENSION PIPE FOR EACH MODEL	53
9. AIR FLOW DATA	57
10. NOISE CRITERION CURVES	69
11. OPTIONAL PARTS.....	80

kW Model

For information on service, please refer to the service manual as follows.

1-1. INDOOR UNIT

Model name	Service Ref.	Service Manual No.
PLA-RP50/60/71/100/125/140BA	PLA-RP50/60/71/100/125/140BA.UK	OCH412 OCB412
PCA-RP50/60/71/100/125/140GA PCA-RP50GA2	PCA-RP50/60/71/100/125/140GA PCA-RP50GA2	OC328
PCA-RP71/125HA	PCA-RP71/125HA	OC329
PKA-RP50GAL	PKA-RP50GAL	OC330
PKA-RP60/71/100FAL PKA-RP50FAL2	PKA-RP60/71/100FAL PKA-RP50FAL2	OC331
PSA-RP71/100/125/140GA	PSA-RP71/100/125/140GA	OC332
PEAD-RP50/60/71/125/140EA PEAD-RP100EA2	PEAD-RP50/60/71/125/140EA.UK PEAD-RP100EA2.UK	HWE05210
PEAD-RP60/71/100GA	PEAD-RP60/71/100GA.UK	HWE05060
PEA-RP200/250/400/500GA	PEA-RP200/250/400/500GA.TH-AF PEA-RP200/250GA.TH-AFMF	HWE0708A

1-2. OUTDOOR UNIT

Model name	Service Ref.	Service Manual No.
PUHZ-P100/125/140VHA2	PUHZ-P100/125/140VHA2.UK	OCH415 OCB415
PUHZ-P200/250YHA	PUHZ-P200/250YHA	OCH424 OCB424

2-1. CEILING CASSETTE TYPE

Model name	Indoor unit		PLA-RP100BA	PLA-RP125BA	PLA-RP140BA	
	Outdoor unit		PUHZ-P100VHA2	PUHZ-P125VHA2	PUHZ-P140VHA2	
Cooling	Capacity	Btu/h	32,100	42,000	46,400	
		kW	9.4(4.9-11.2)	12.3(5.5-14.0)	13.6(5.5-15.0)	
	Total input	kW	3.12	4.09	5.21	
	EER		3.01	3.01	2.61	
	Energy label class		B	B	D	
	SHF		0.74	0.71	0.71	
Heating	Capacity	Btu/h	38,200	47,800	54,600	
		kW	11.2(4.5-12.5)	14.0(5.0-16.0)	16.0(5.0-18.0)	
	Total input	kW	3.28	4.11	4.98	
	COP		3.41	3.41	3.21	
	Energy label class		B	B	C	
	Booster heater	kW	-	-	-	
Power supply	Phase	φ	1			
	Cycle	Hz	50			
	Voltage	V	230			
	Breaker size	A	32		40	
Indoor unit	Air flow	CMM	20-23-26-30	22-25-28-31	24-26-29-32	
		(Low-Medium2-Medium1-High)	CFM	710-810-920-1060	780-880-990-1090	850-920-1020-1130
	External pressure	Pa	0			
	Sound level	dB(A)	32-34-37-40	34-36-39-41	36-39-42-44	
	(Low-Medium2-Medium1-High)					
	External finish (Panel)		White Munsell 6.4Y 8.9/0.4			
	Dimension	Unit (Panel)	W : mm	840 (950)		
			D : mm	840 (950)		
			H : mm	298 (35)		
			W : inch	33-1/16 (37-3/8)		
			D : inch	33-1/16 (37-3/8)		
			H : inch	11-3/4 (1-3/8)		
	Weight	Unit (Panel)	kg	25 (6)		27 (6)
			lbs	55 (13)		60 (13)
Field drain pipe O.D.		mm	32			
		inch	1-1/4			
Outdoor unit	Air flow	CMM	60	100		
		CFM	2,120	3,530		
	Sound level at cooling	dB(A)	50	51	52	
	Sound level at heating	dB(A)	54	55	56	
	External finish		Ivory Munsell 5Y 7/1			
	Dimension	Unit (Panel)	W : mm	950		
			D : mm	330+30		
			H : mm	943	1350	
			W : inch	37-3/8		
			D : inch	13 + 1-3/16		
			H : inch	37-1/8	53-1/8	
Weight	Unit (Panel)	kg	75	99		
		lbs	165	218		
Refrigerant pipe size	Gas side O.D.	mm	15.88			
		inch	5/8			
	Liquid side O.D.	mm	9.52			
		inch	3/8			
Refrigerant pipe length	Height difference	m	Max. 30			
	Length	m	Max. 50			

- NOTE:**
- Rating conditions (ISO T1)
Cooling Indoor : D.B. 27°C (80°F) W.B. 19°C (66°F) Outdoor : D.B. 35°C (95°F) W.B. 24°C (75°F)
Heating Indoor : D.B. 20°C (68°F) Outdoor : D.B. 7°C (45°F) W.B. 6°C (43°F)
Refrigerant piping length (one way) : 5m (16ft.)
 - Guaranteed operating range
 - Guaranteed voltage
198~264V, 50Hz

		Indoor	Outdoor
Cooling	Upper limit	D.B. 35°C, W.B. 22.5°C	D.B. 46°C
	Lower limit	D.B. 19°C, W.B. 15°C	D.B. -5°C *
Heating	Upper limit	D.B. 28°C	D.B. 21°C, W.B. 15°C
	Lower limit	D.B. 17°C	D.B. -11°C, W.B. -12°C

- Above data are based on the indicated voltage.
Indoor unit Single phase 230V 50Hz
Outdoor unit Single phase 230V 50Hz
* If optional air protect guide is installed : D.B.-15°C

2-2. CEILING-CONCEALED TYPE

Model name	Indoor unit		PEAD-RP100EA2	PEAD-RP125EA	PEAD-RP140EA	
	Outdoor unit		PUHZ-P100VHA2	PUHZ-P125VHA2	PUHZ-P140VHA2	
Cooling	Capacity	Btu/h	32,100	42,000	46,400	
		kW	9.4(4.9-11.2)	12.3(5.5-14.0)	13.6(5.5-15.0)	
	Total input	kW	3.12	4.38	5.21	
	EER		3.01	2.81	2.61	
	Energy label class		B	C	D	
	SHF		0.86	0.83	0.84	
Heating	Capacity	Btu/h	38,200	47,800	54,600	
		kW	11.2(4.5-12.5)	14.0(5.0-16.0)	16.0(5.0-18.0)	
	Total input	kW	3.28	4.11	4.98	
	COP		3.41	3.41	3.21	
	Energy label class		B	B	C	
	Booster heater		kW	-	-	-
Power supply	Phase	φ	1			
	Cycle	Hz	50			
	Voltage	V	230			
	Breaker size	A	32	40		
Indoor unit	Air flow (Low-High)	CMM	33.5-42	33.5-42	36.5-46	
		CFM	1183-1483	1183-1483	1288-1624	
	External pressure	Pa	70(130)			
	Sound level (Low-High)	dB(A)	44-50 (130Pa : 46-52)	44-50 (130Pa : 46-52)	46-51 (130Pa : 47-53)	
			Galvanized sheets			
	Dimension	W : mm	1415		1715	
			740			
		H : mm		325		
		W : inch	55-11/16		67-1/2	
			29-1/8			
		H : inch		12-13/16		
Weight	kg	65	65	70		
	lbs	143	143	154		
Unit drain pipe		R1(External thread)				
Outdoor unit	Air flow	CMM	60	100		
		CFM	2,120	3,530		
	Sound level at cooling	dB(A)	50	51	52	
	Sound level at heating	dB(A)	54	55	56	
	External finish		Ivory Munsell 5Y 7/1			
	Dimension	W : mm	950			
			330+30			
		H : mm		943	1350	
		W : inch		37-3/8		
		D : inch		13 + 1-3/16		
		H : inch		37-1/8	53-1/8	
Weight	kg	75	99			
	lbs	165	218			
Refrigerant pipe size	Gas side O.D.	mm	15.88			
		inch	5/8			
	Liquid side O.D.	mm	9.52			
		inch	3/8			
Refrigerant pipe length	Height difference	m	Max. 30			
	Length	m	Max. 50			

NOTE: 1. Rating conditions (ISO T1)

Cooling Indoor : D.B. 27°C (80°F) W.B. 19°C (66°F) Outdoor : D.B. 35°C (95°F) W.B. 24°C (75°F)
 Heating Indoor : D.B. 20°C (68°F) Outdoor : D.B. 7°C (45°F) W.B. 6°C (43°F)

Refrigerant piping length (one way) : 5m (16ft.)

2. Guaranteed operating range

		Indoor	Outdoor
Cooling	Upper limit	D.B. 35°C, W.B. 22.5°C	D.B. 46°C
	Lower limit	D.B. 19°C, W.B. 15°C	D.B. -5°C *
Heating	Upper limit	D.B. 28°C	D.B. 21°C, W.B. 15°C
	Lower limit	D.B. 17°C	D.B. -11°C, W.B. -12°C

3. Guaranteed voltage
198~264V, 50Hz

4. Above data are based on the indicated voltage.

Indoor unit Single phase 230V 50Hz
 Outdoor unit Single phase 230V 50Hz

* If optional air protect guide is installed : D.B. -15°C

Model name	Indoor unit		PEAD-RP100GA
	Outdoor unit		PUHZ-P100VHA2
Cooling	Capacity	Btu/h	32,100
		kW	9.4(4.9-11.2)
	Total input	kW	3.60
	EER		2.61
	Energy label class		D
	SHF		0.85
Heating	Capacity	Btu/h	38,200
		kW	11.2(4.5-12.5)
	Total input	kW	3.49
	COP		3.21
	Energy label class		C
	Booster heater	kW	-
Power supply	Phase	ϕ	1
	Cycle	Hz	50
	Voltage	V	230
	Breaker size	A	32
Indoor unit	Air flow (Low-High)	CMM	26.5-33
		CFM	935-1165
	External pressure	Pa	10/50/70
	Sound level (Low-High)	dB(A)	40-43/42-45/42-46 (10/50/70Pa)
	External finish		Galvanized sheets
	Dimension	W : mm	1411
		D : mm	740
		H : mm	275
		W : inch	55-9/16
		D : inch	29-1/8
		H : inch	10-13/16
	Weight	kg	50
		lbs	111
Unit drain pipe O.D.	mm	32	
	inch	1-1/4	
Outdoor unit	Air flow	CMM	60
		CFM	2,120
	Sound level at cooling	dB(A)	50
	Sound level at heating	dB(A)	54
	External finish		Ivory Munsell 5Y 7/1
	Dimension	W : mm	950
		D : mm	330+30
		H : mm	943
		W : inch	37-3/8
		D : inch	13 + 1-3/16
		H : inch	37-1/8
Weight	kg	75	
	lbs	165	
Refrigerant pipe size	Gas side O.D.	mm	15.88
		inch	5/8
	Liquid side O.D.	mm	9.52
		inch	3/8
Refrigerant pipe length	Height difference	m	Max. 30
	Length	m	Max. 50

NOTE: 1. Rating conditions (ISO T1)
Cooling Indoor : D.B. 27°C (80°F) W.B. 19°C (66°F) Outdoor : D.B. 35°C (95°F) W.B. 24°C (75°F)
Heating Indoor : D.B. 20°C (68°F) Outdoor : D.B. 7°C (45°F) W.B. 6°C (43°F)
Refrigerant piping length (one way) : 5m (16ft.)

2. Guaranteed operating range

		Indoor	Outdoor
Cooling	Upper limit	D.B. 35°C, W.B. 22.5°C	D.B. 46°C
	Lower limit	D.B. 19°C, W.B. 15°C	D.B. -5°C ※1
Heating	Upper limit	D.B. 28°C	D.B. 21°C, W.B. 15°C
	Lower limit	D.B. 17°C	D.B. -11°C, W.B. -12°C

3. Guaranteed voltage
198~264V, 50Hz

4. Above data are based on the indicated voltage.
Indoor unit Single phase 230V 50Hz
Outdoor unit Single phase 230V 50Hz

※1. If optional air protect guide is installed : D.B.-15°C

Model name	Indoor unit	PEA-RP200GA		PEA-RP250GA	
	Outdoor unit	PUHZ-P200YHA		PUHZ-P250YHA	
Cooling	Capacity	Btu/h	65,000		75,000
		kW	19.0(9.0-22.4)		22.0(11.2-28.0)
	Total input	kW	7.21		8.44
	EER		2.64		2.61
	Energy label class		D		D
	SHF		0.81		0.86
Heating	Capacity	Btu/h	76,000		92,000
		kW	22.4(9.5-25.0)		27.0(12.5-31.5)
	Total input	kW	7.36		8.47
	COP		3.04		3.19
	Energy label class		D		D
	Booster heater	kW	-		-
Power supply	Phase	ϕ	3		
	Cycle	Hz	50		
	Voltage	V	400		
	Breaker size	A	Indoor 15 / Outdoor 32		
Indoor unit	Air flow (Low-High)	CMM	52-65		64-80
		CFM	1835-2295		2260-2825
	External pressure	Pa	150		
	Sound level (Low-High)	dB(A)	48-51		49-52
	External finish		Galvanized steel		
	Dimension	W : mm	1400		1600
		D : mm	634		
		H : mm	400		
		W : inch	55-1/8		63
		D : inch	25		
		H : inch	15-3/4		
	Weight	kg	70		77
		lbs	155		170
Unit drain pipe		R1			
Outdoor unit	Air flow	CMM	130		
		CFM	4590		
	Sound level at cooling	dB(A)	59		
	Sound level at heating	dB(A)	59		
	External finish		Ivory Munsell 3Y 7.8/1.1		
	Dimension	W : mm	950		
		D : mm	330+30		
		H : mm	1350		
		W : inch	37-3/8		
		D : inch	13 + 1-3/16		
		H : inch	53-1/8		
Weight	kg	126		133	
	lbs	278		294	
Refrigerant pipe size	Gas side O.D.	mm	25.4		
		inch	1		
	Liquid side O.D.	mm	9.52		12.7
		inch	3/8		1/2
Refrigerant pipe length	Height difference	m	Max. 30		
	Length	m	Max. 70		

NOTE: 1. Rating conditions (ISO T1)
Cooling Indoor : D.B. 27°C (80°F) W.B. 19°C (66°F) Outdoor : D.B. 35°C (95°F) W.B. 24°C (75°F)
Heating Indoor : D.B. 20°C (68°F) Outdoor : D.B. 7°C (45°F) W.B. 6°C (43°F)
Refrigerant piping length (one way) : 5m (16ft.)

2. Guaranteed operating range

		Indoor	Outdoor
Cooling	Upper limit	D.B. 35°C, W.B. 22.5°C	D.B. 46°C
	Lower limit	D.B. 19°C, W.B. 15°C	D.B. -5°C ※1
Heating	Upper limit	D.B. 28°C	D.B. 21°C, W.B. 15°C
	Lower limit	D.B. 17°C	D.B. -11°C, W.B. -12°C

3. Guaranteed voltage
342~457V, 50Hz

4. Above data are based on the indicated voltage.

Indoor unit 3 phase 400V 50Hz

Outdoor unit 3 phase 400V 50Hz

※1. If optional air protect guide is installed : D.B. -15°C



Model name	Indoor unit		PEA-RP400GA	PEA-RP500GA	
	Outdoor unit		PUHZ-P200YHA×2	PUHZ-P250YHA×2	
Cooling	Capacity	Btu/h	130,000	150,000	
		kW	38.0(18.0-44.8)	44.0(22.4-56.0)	
	Total input	kW	13.97	17.36	
	EER		2.72	2.53	
	Energy label class		D	E	
	SHF		0.75	0.77	
Heating	Capacity	Btu/h	153,000	184,000	
		kW	44.8(19.0-50.0)	54.0(25.0-63.0)	
	Total input	kW	14.27	17.42	
	COP		3.14	3.10	
	Energy label class		D	D	
	Booster heater		kW	-	-
Power supply	Phase	φ	3		
	Cycle	Hz	50		
	Voltage	V	400		
	Breaker size	A	Indoor 15 / Outdoor 32 ×2		
Indoor unit	Air flow (High)	CMM	120	160	
		CFM	4240	5650	
	External pressure	Pa	150		
	Sound level (High)	dB(A)	52	53	
	External finish		Galvanized steel		
	Dimension	W : mm	1947		
		D : mm	764		
		H : mm	595		
		W : inch	79-11/16		
		D : inch	30-1/8		
		H : inch	23-7/16		
	Weight	kg	130	133	
		lbs	286	293	
	Unit drain pipe		R1		
Outdoor unit (Per 1 outdoor unit)	Air flow	CMM	130		
		CFM	4590		
	Sound level at cooling	dB(A)	59		
	Sound level at heating	dB(A)	59		
	External finish		Ivory Munsell 3Y 7.8/1.1		
	Dimension	W : mm	950		
		D : mm	330+30		
		H : mm	1350		
		W : inch	37-3/8		
		D : inch	13 + 1-3/16		
H : inch		53-1/8			
Weight	kg	126	133		
	lbs	278	294		
Refrigerant pipe size	Gas side O.D.	mm	25.4 × 2		
		inch	1 × 2		
	Liquid side O.D.	mm	9.52 × 2	12.7 × 2	
		inch	3/8 × 2	1/2 × 2	
Refrigerant pipe length	Height difference	m	Max. 30		
	Length	m	Max. 70 (per 1 outdoor unit)		

NOTE: 1. Rating conditions (ISO T1)

Cooling Indoor : D.B. 27°C (80°F) W.B. 19°C (66°F) Outdoor : D.B. 35°C (95°F) W.B. 24°C (75°F)
 Heating Indoor : D.B. 20°C (68°F) Outdoor : D.B. 7°C (45°F) W.B. 6°C (43°F)
 Refrigerant piping length (one way) : 5m (16ft.)

2. Guaranteed operating range

		Indoor	Outdoor
Cooling	Upper limit	D.B. 35°C, W.B. 22.5°C	D.B. 46°C
	Lower limit	D.B. 19°C, W.B. 15°C	D.B. -5°C ※1
Heating	Upper limit	D.B. 28°C	D.B. 21°C, W.B. 15°C
	Lower limit	D.B. 17°C	D.B. -11°C, W.B. -12°C

3. Guaranteed voltage
342-457V, 50Hz

4. Above data are based on the indicated voltage.
 Indoor unit 3 phase 400V 50Hz
 Outdoor unit 3 phase 400V 50Hz

※1. If optional air protect guide is installed : D.B.-15°C

2-3. WALL-MOUNTED TYPE

Model name	Indoor unit		PKA-RP100FAL
	Outdoor unit		PUHZ-P100VHA2
Cooling	Capacity	Btu/h	32,100
		kW	9.4(4.9-11.2)
	Total input	kW	3.12
	EER		3.01
	Energy label class		B
	SHF		0.79
Heating	Capacity	Btu/h	38,200
		kW	11.2(4.5-12.5)
	Total input	kW	3.49
	COP		3.21
	Energy label class		C
	Booster heater		kW
Power supply	Phase	φ	1
	Cycle	Hz	50
	Voltage	V	230
	Breaker size	A	32
Indoor unit	Air flow (Low-High)	CMM	22-28
		CFM	780-990
	External pressure	Pa	0
	Sound level (Low-High)	dB(A)	41-46
	External finish		Munsell 3.4Y 7.7/0.8
	Dimension	W : mm	1680
		D : mm	235
		H : mm	340
		W : inch	66-1/8
		D : inch	9-1/4
		H : inch	13-3/8
	Weight	kg	28
		lbs	62
Field drain pipe I.D.	mm	20	
	inch	13/16	
Outdoor unit	Air flow	CMM	60
		CFM	2,120
	Sound level at cooling	dB(A)	50
	Sound level at heating	dB(A)	54
	External finish		Ivory Munsell 5Y 7/1
	Dimension	W : mm	950
		D : mm	330+30
		H : mm	943
		W : inch	37-3/8
		D : inch	13 + 1-3/16
H : inch		37-1/8	
Weight	kg	75	
	lbs	165	
Refrigerant pipe size	Gas side O.D.	mm	15.88
		inch	5/8
	Liquid side O.D.	mm	9.52
		inch	3/8
Refrigerant pipe length	Height difference	m	Max. 30
	Length	m	Max. 50

- NOTE:**
- Rating conditions (ISO T1)
 Cooling Indoor : D.B. 27°C (80°F) W.B. 19°C (66°F) Outdoor : D.B. 35°C (95°F) W.B. 24°C (75°F)
 Heating Indoor : D.B. 20°C (68°F) Outdoor : D.B. 7°C (45°F) W.B. 6°C (43°F)
 Refrigerant piping length (one way) : 5m (16ft.)

- Guaranteed operating range

		Indoor	Outdoor
Cooling	Upper limit	D.B. 35°C, W.B. 22.5°C	D.B. 46°C
	Lower limit	D.B. 19°C, W.B. 15°C	D.B. -5°C ※1
Heating	Upper limit	D.B. 28°C	D.B. 21°C, W.B. 15°C
	Lower limit	D.B. 17°C	D.B. -11°C, W.B. -12°C

- Guaranteed voltage
198~264V, 50Hz

- Above data are based on the indicated voltage.
 Indoor unit Single phase 230V 50Hz
 Outdoor unit Single phase 230V 50Hz

※1. If optional air protect guide is installed : D.B.-15°C

2-4. CEILING-SUSPENDED TYPE

Model name	Indoor unit		PCA-RP100GA	PCA-RP125GA	PCA-RP140GA
	Outdoor unit		PUHZ-P100VHA2	PUHZ-P125VHA2	PUHZ-P140VHA2
Cooling	Capacity	Btu/h	32,100	42,000	46,400
		kW	9.4(4.9-11.2)	12.3(5.5-14.0)	13.6(5.5-15.0)
	Total input	kW	3.35	4.38	5.21
	EER		2.81	2.81	2.61
	Energy label class		C	C	D
	SHF		0.77	0.78	0.76
Heating	Capacity	Btu/h	38,200	47,800	54,600
		kW	11.2(4.5-12.5)	14.0(5.0-16.0)	16.0(5.0-18.0)
	Total input	kW	3.49	4.98	4.98
	COP		3.21	2.81	3.21
	Energy label class		C	D	C
	Booster heater		kW	-	-
Power supply	Phase	φ	1		
	Cycle	Hz	50		
	Voltage	V	230		
	Breaker size	A	32		40
Indoor unit	Air flow	CMM	20-21-23-25	27-30-32-34	
	(Low-Medium2-Medium1-High)	CFM	705-840-810-885	955-1060-1130-1200	
	External pressure	Pa	0		
	Sound level	dB(A)	40-41-43-45	41-43-45-46	42-44-46-48
	(Low-Medium2-Medium1-High)				
	External finish		White Munsell 0.70Y 8.59/0.97		
	Dimension	W : mm	1310	1620	
		D : mm	680		
		H : mm	270		
		W : inch	51-9/16	63-3/4	
		D : inch	26-3/4		
		H : inch	10-5/8		
	Weight	kg	37	43	45
		lbs	82	95	99
Field drain pipe O.D.	mm	26			
	inch	1			
Outdoor unit	Air flow	CMM	60	100	
		CFM	2,120	3,530	
	Sound level at cooling	dB(A)	50	51	52
	Sound level at heating	dB(A)	54	55	56
	External finish		Ivory Munsell 5Y 7/1		
	Dimension	W : mm	950		
		D : mm	330+30		
		H : mm	943	1350	
		W : inch	37-3/8		
		D : inch	13 + 1-3/16		
H : inch		37-1/8	53-1/8		
Weight	kg	75	99		
	lbs	165	218		
Refrigerant pipe size	Gas side O.D.	mm	15.88		
		inch	5/8		
	Liquid side O.D.	mm	9.52		
		inch	3/8		
Refrigerant pipe length	Height difference	m	Max. 30		
	Length	m	Max. 50		

NOTE: 1. Rating conditions (ISO T1)

Cooling Indoor : D.B. 27°C (80°F) W.B. 19°C (66°F) Outdoor : D.B. 35°C (95°F) W.B. 24°C (75°F)
 Heating Indoor : D.B. 20°C (68°F) Outdoor : D.B. 7°C (45°F) W.B. 6°C (43°F)

Refrigerant piping length (one way) : 5m (16ft.)

2. Guaranteed operating range

		Indoor	Outdoor
Cooling	Upper limit	D.B. 35°C, W.B. 22.5°C	D.B. 46°C
	Lower limit	D.B. 19°C, W.B. 15°C	D.B. -5°C *
Heating	Upper limit	D.B. 28°C	D.B. 21°C, W.B. 15°C
	Lower limit	D.B. 17°C	D.B. -11°C, W.B. -12°C

3. Guaranteed voltage
198-264V, 50Hz

4. Above data are based on the indicated voltage.

Indoor unit Single phase 230V 50Hz

Outdoor unit Single phase 230V 50Hz

* If optional air protect guide is installed : D.B.-15°C

Model name	Indoor unit		PCA-RP125HA
	Outdoor unit		PUHZ-P125VHA2
Cooling	Capacity	Btu/h	42,000
		kW	12.3(5.5-14.0)
	Total input	kW	4.38
	EER		2.81
	Energy label class		C
	SHF		0.78
Heating	Capacity	Btu/h	47,100
		kW	13.8(5.0-16.0)
	Total input	kW	4.30
	COP		3.21
	Energy label class		C
	Booster heater		kW
Power supply	Phase	φ	1
	Cycle	Hz	50
	Voltage	V	230
	Breaker size	A	25
Indoor unit	Air flow (Low-High)	CMM	30-38
		CFM	1060-1350
	External pressure	Pa	0
	Sound level (Low-High)	dB(A)	44-50
	External finish		Stainless steel
	Dimension	W : mm	1520
		D : mm	650
		H : mm	280
		W : inch	59-7/8
		D : inch	25-5/8
		H : inch	11
	Weight	kg	56
		lbs	124
Field drain pipe O.D.	mm	26	
	inch	1	
Outdoor unit	Air flow	CMM	100
		CFM	3,530
	Sound level at cooling	dB(A)	51
	Sound level at heating	dB(A)	55
	External finish		Ivory Munsell 5Y 7/1
	Dimension	W : mm	950
		D : mm	330+30
		H : mm	1350
		W : inch	37-3/8
		D : inch	13 + 1-3/16
H : inch		53-1/8	
Weight	kg	99	
	lbs	218	
Refrigerant pipe size	Gas side O.D.	mm	15.88
		inch	5/8
	Liquid side O.D.	mm	9.52
		inch	3/8
Refrigerant pipe length	Height difference	m	Max. 30
	Length	m	Max. 50

NOTE: 1. Rating conditions (ISO T1)
Cooling Indoor : D.B. 27°C (80°F) W.B. 19°C (66°F) Outdoor : D.B. 35°C (95°F) W.B. 24°C (75°F)
Heating Indoor : D.B. 20°C (68°F) Outdoor : D.B. 7°C (45°F) W.B. 6°C (43°F)
Refrigerant piping length (one way) : 5m (16ft.)

2. Guaranteed operating range

		Indoor	Outdoor
Cooling	Upper limit	D.B. 35°C, W.B. 22.5°C	D.B. 46°C
	Lower limit	D.B. 19°C, W.B. 15°C	D.B. -5°C ※1
Heating	Upper limit	D.B. 28°C	D.B. 21°C, W.B. 15°C
	Lower limit	D.B. 17°C	D.B. -11°C, W.B. -12°C

3. Guaranteed voltage
198~264V, 50Hz

4. Above data are based on the indicated voltage.
Indoor unit Single phase 230V 50Hz
Outdoor unit Single phase 230V 50Hz

※1. If optional air protect guide is installed : D.B.-15°C

2-5. FLOOR STANDING TYPE

Model name	Indoor unit		PSA-RP100GA	PSA-RP125GA	PSA-RP140GA
	Outdoor unit		PUHZ-P100VHA2	PUHZ-P125VHA2	PUHZ-P140VHA2
Cooling	Capacity	Btu/h	32,100	42,000	46,400
		kW	9.4(4.9-11.2)	12.3(5.5-14.0)	13.6(5.5-15.0)
	Total input	kW	3.12	4.38	5.64
	EER		3.01	2.81	2.41
	Energy label class		B	C	E
	SHF		0.83	0.76	0.75
Heating	Capacity	Btu/h	38,200	47,800	54,600
		kW	11.2(4.5-12.5)	14.0(5.0-16.0)	16.0(5.0-18.0)
	Total input	kW	3.28	4.98	5.69
	COP		3.41	2.81	2.81
	Energy label class		B	D	D
	Booster heater	kW	-	-	-
Power supply	Phase	φ	1		
	Cycle	Hz	50		
	Voltage	V	230		
	Breaker size	A	32		40
Indoor unit	Air flow (Low-High)	CMM	24-31	26-33	27-35
		CFM	850-1060	920-1165	955-1240
	External pressure	Pa	0		
	Sound level (Low-High)	dB(A)	44-49	46-51	47-52
	External finish		White Munsell 0.70Y 8.59/0.97		
	Dimension	W : mm	600		
		D : mm	350		
		H : mm	1900		
		W : inch	23-5/8		
		D : inch	13-3/4		
		H : inch	74-13/16		
	Weight	kg	51		53
		lbs	112		117
Field drain pipe I.D.	mm	20			
	inch	13/16			
Outdoor unit	Air flow	CMM	60	100	
		CFM	2,120	3,530	
	Sound level at cooling	dB(A)	50	51	52
	Sound level at heating	dB(A)	54	55	56
	External finish		Ivory Munsell 5Y 7/1		
	Dimension	W : mm	950		
		D : mm	330+30		
		H : mm	943	1350	
		W : inch	37-3/8		
		D : inch	13 + 1-3/16		
H : inch		37-1/8	53-1/8		
Weight	kg	75	99		
	lbs	165	218		
Refrigerant pipe size	Gas side O.D.	mm	15.88		
		inch	5/8		
	Liquid side O.D.	mm	9.52		
		inch	3/8		
Refrigerant pipe length	Height difference	m	Max. 30		
	Length	m	Max. 50		

NOTE: 1. Rating conditions (ISO T1)

Cooling Indoor : D.B. 27°C (80°F) W.B. 19°C (66°F) Outdoor : D.B. 35°C (95°F) W.B. 24°C (75°F)

Heating Indoor : D.B. 20°C (68°F) Outdoor : D.B. 7°C (45°F) W.B. 6°C (43°F)

Refrigerant piping length (one way) : 5m (16ft.)

2. Guaranteed operating range

		Indoor	Outdoor
Cooling	Upper limit	D.B. 35°C, W.B. 22.5°C	D.B. 46°C
	Lower limit	D.B. 19°C, W.B. 15°C	D.B. -5°C *
Heating	Upper limit	D.B. 28°C	D.B. 21°C, W.B. 15°C
	Lower limit	D.B. 17°C	D.B. -11°C, W.B. -12°C

3. Guaranteed voltage

198-264V, 50Hz

4. Above data are based on the indicated voltage.

Indoor unit Single phase 230V 50Hz

Outdoor unit Single phase 230V 50Hz

* If optional air protect guide is installed : D.B.-15°C

Unit : mm

INDOOR UNIT
PLA-RP50BA **PLA-RP60BA** **PLA-RP71BA**
PLA-RP100BA **PLA-RP125BA** **PLA-RP140BA**

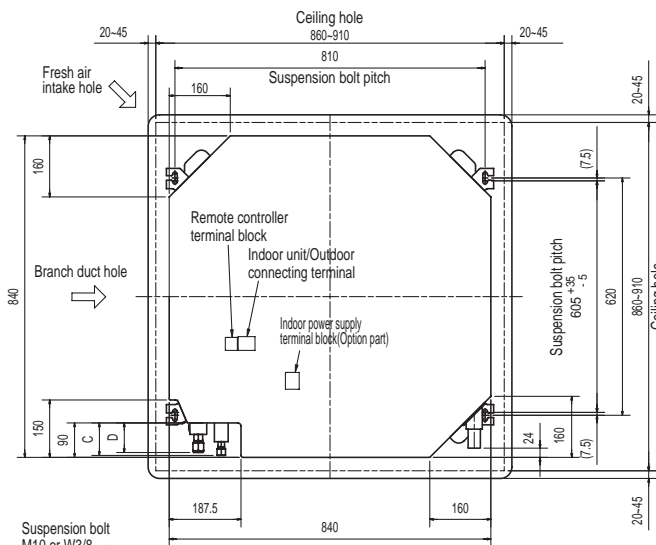

Detail connecting of branch duct(Both aspects)

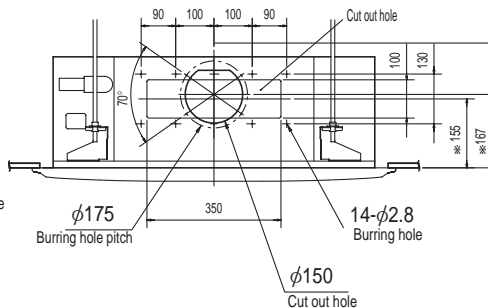

Detail drawing of fresh air intake hole

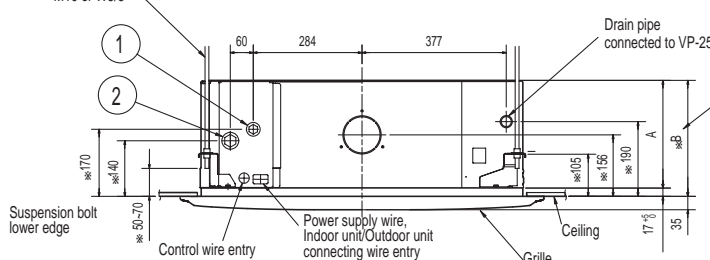
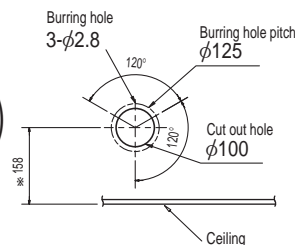

Drain pipe connected to VP-25 (Connected the attached flexible pipe or socket.)
 Keep approximately 10 to 15mm space between unit ceiling and ceiling slab.

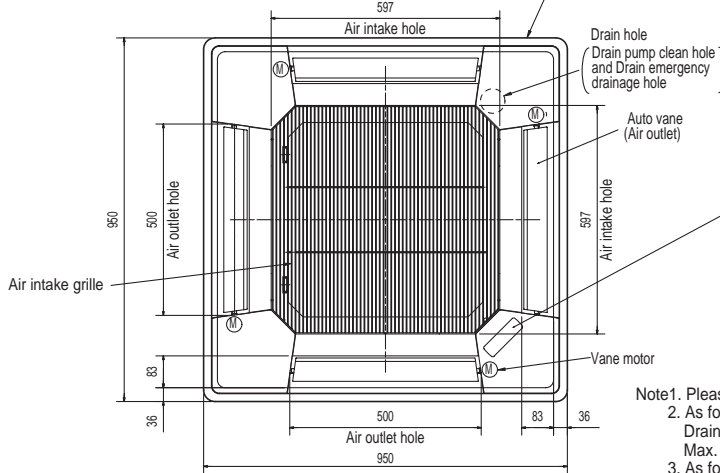

In case of standard grille : PLP-6BA / PLP-6BAMD



In case of Auto-Grille : PLP-6BAJ

In case of wireless remote controller : PLP-6BALM

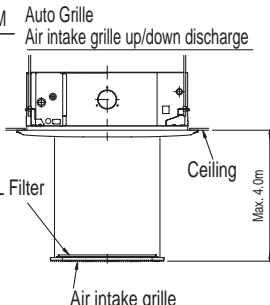
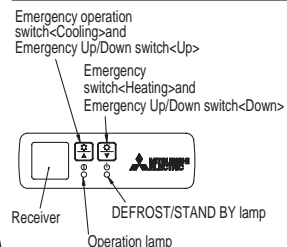

- Note1. Please choose the grille from a standard grille or Auto-Grille.
 2. As for drain pipe, please use VP-25(O.D. φ32 PVC TUBE). Drain pump is included. Max. lifting height is 850mm from the ceiling.
 3. As for suspension bolt, please use M10 or W3/8. (Procured at local site)
 4. Electrical box may be removed for the service purpose. Make sure to slack the electrical wire little bit for control/ power wires connection.
 5. The height of the indoor unit is able to be adjusted with the grille attached.
 6. For the installation of the optional high efficiency filter or optional multi-functional casement.
 1) Requires E or more space between transom and ceiling for the installation.
 2) Add 135 mm to the dimensions * marked on the figure.
 3) The optional high efficiency filter becomes optional multi-functional casement and concomitant use.
 7. When installing the branch ducts, be sure to insulate adequately. Otherwise condensation and dripping may occur. (It becomes the cause of dew drops/Water dew.)
 8. As for necessary installation/service space, please refer to the left figure.

Models	①	②	A	B	C	D	E
PLA-RP50BA	Refrigerant pipe ---φ6.35 Flared connection ---1/4 inch	Refrigerant pipe ---φ12.7 Flared connection ---1/2 inch			80		
PLA-RP60BA	Refrigerant pipe φ6.35 / φ9.52 Flared connection 1/4 inch/3/8 inch (compatible)	Refrigerant pipe ---φ15.88 Flared connection ---5/8 inch	241	258	87		400
PLA-RP71BA	Refrigerant pipe ---φ9.52 Flared connection ---3/8 inch				85	77	
PLA-RP100,125,140BA			281	298			440

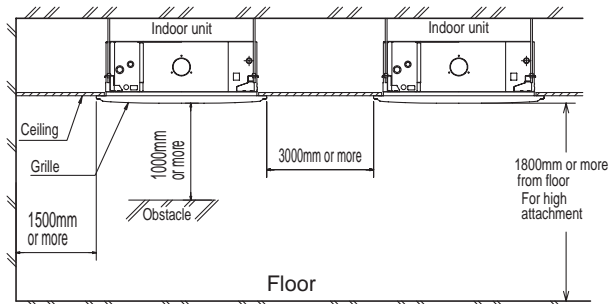

PEAD-RP50EA PEAD-RP60EA

Unit : mm

Model	A	B	C	D	E	F	G
RP50	772	305	-	830	804	R410A Outdoor unit : 6.35 * R407C Outdoor unit : 9.52	R410A Outdoor unit : 12.7 * R407C Outdoor unit : 15.88
RP60	1012	280	290	1070	1044	Outdoor unit (SUZ) : 6.35 R407C Outdoor unit : 9.52 *	15.88

* Initial setting

- ① Refrigerant piping flare connection (liquid ϕ F copper tube):HP
- ② Refrigerant piping flare connection (gas ϕ G copper tube):LP
- ③ Drain R1 (External thread)
- ④ Electrical parts box
- ⑤ Drain Pump (Option)
- ⑥ Drain Pipe (Option) ... Flexible joint VP-25(I.D. ϕ 32)
- ⑦ Filter

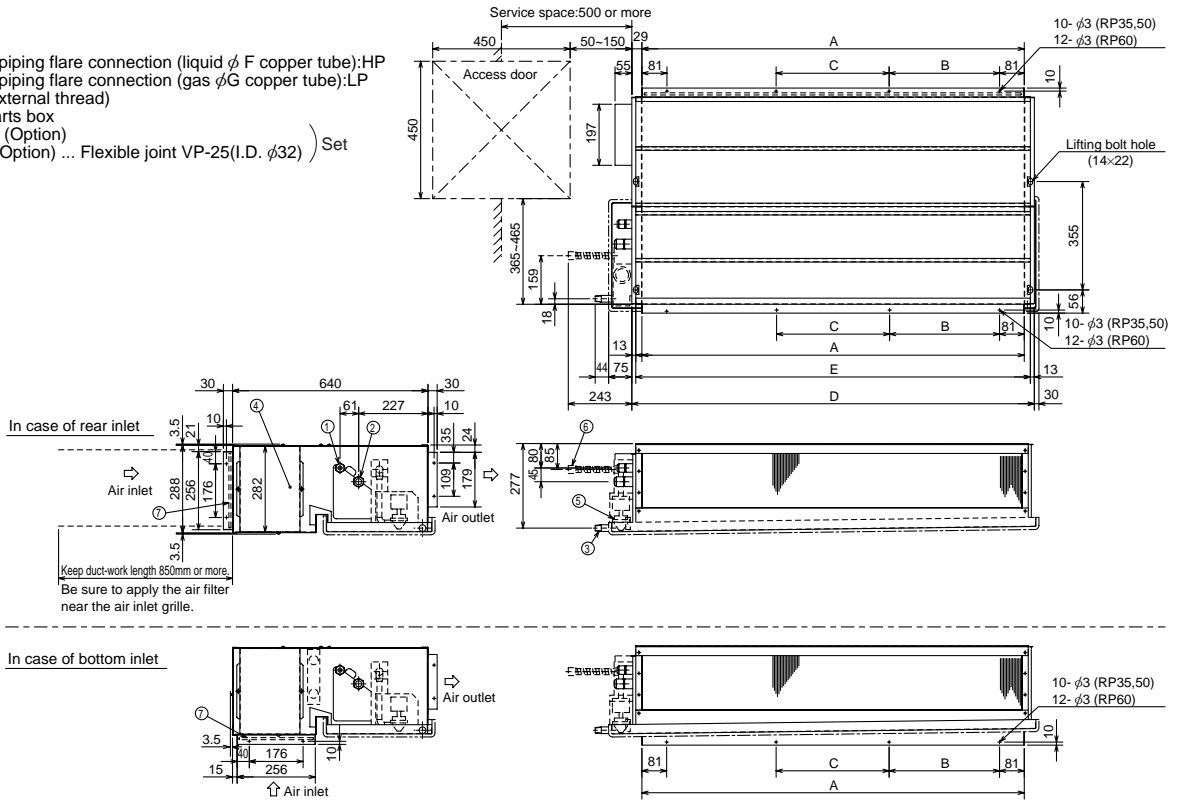

PEAD-RP71EA PEAD-RP100EA2 PEAD-RP125EA PEAD-RP140EA

Model	A	B	C	D	E	F
RP71	1012	280	290	1070	1044	15.88
RP100,125	1252	360	370	1310	1284	R410A Outdoor unit : 15.88 * R407C outdoor unit : 19.05
RP140	1552	460	470	1610	1584	

* Initial setting

- ① Refrigerant piping flare connection (liquid ϕ 9.52 copper tube):HP
- ② Refrigerant piping flare connection (gas ϕ F copper tube):LP
- ③ Drain R1 (External thread)
- ④ Electrical parts box
- ⑤ Drain Pump (Option)
- ⑥ Drain Pipe (Option) ... Flexible joint VP25(I.D. ϕ 32)
- ⑦ Filter

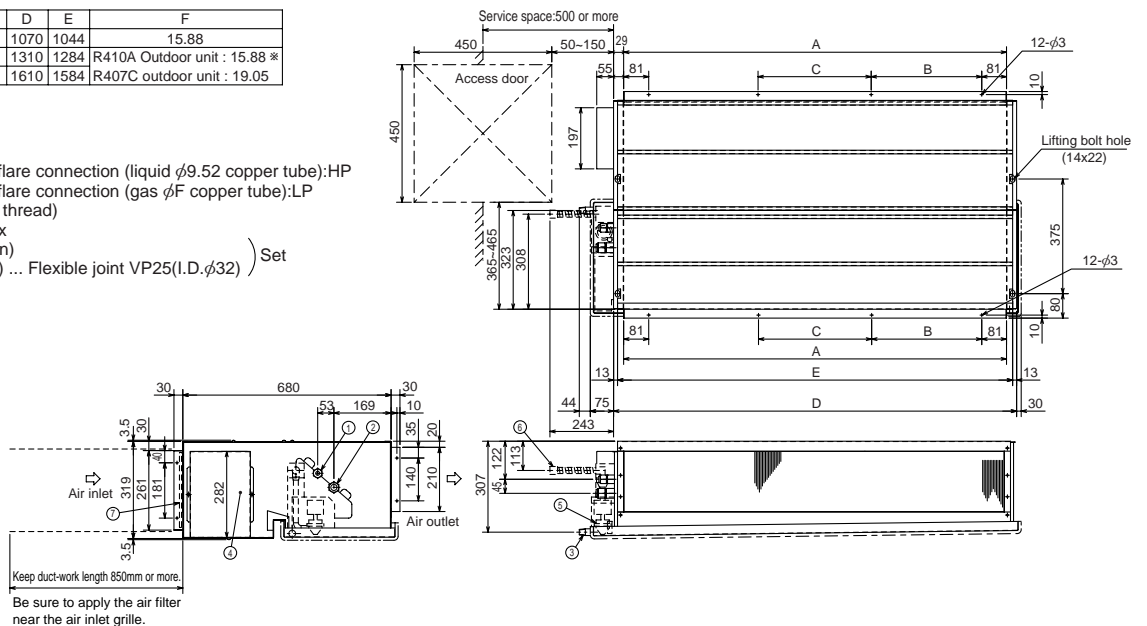

**PEAD-RP60GA
PEAD-RP71GA
PEAD-RP100GA**

Unit : mm

- ① Refrigerant piping flare connection(liquid øH copper tube): HP
- ② Refrigerant piping flare connection(gas øJ copper tube): LP
- ③ Electrical parts box *
- ④ Terminal bed : Power source
- ⑤ Terminal bed : Remote control
- ⑥ Filter
- ⑦ Drain pan (R1 External thread: ø34) (*:Fixable to opposition side.)

* NOTE: IT IS NECESSARY TO REMOVE THE CEILING PARTS OR TO KEEP THE MAINTENANCE HOLE OF OVER UNIT SIZE WHEN YOU HAVE A MAINTENANCE OR SERVICE THE FOLLOWING PARTS.
SERVICE: MOTOR,SIROCCO FAN,HEAT EXCHANGER,DRAIN PAN
(EXCHANGE) FILTER(IN CASE OF INDOOR UNIT HAVE INLET DUCT.)
MAINTENANCE: HEAT EXCHANGER,DRAIN PAN(SURFACE WASHING)
(WASHING) FILTER(IN CASE OF INDOOR UNIT HAVE INLET DUCT.)

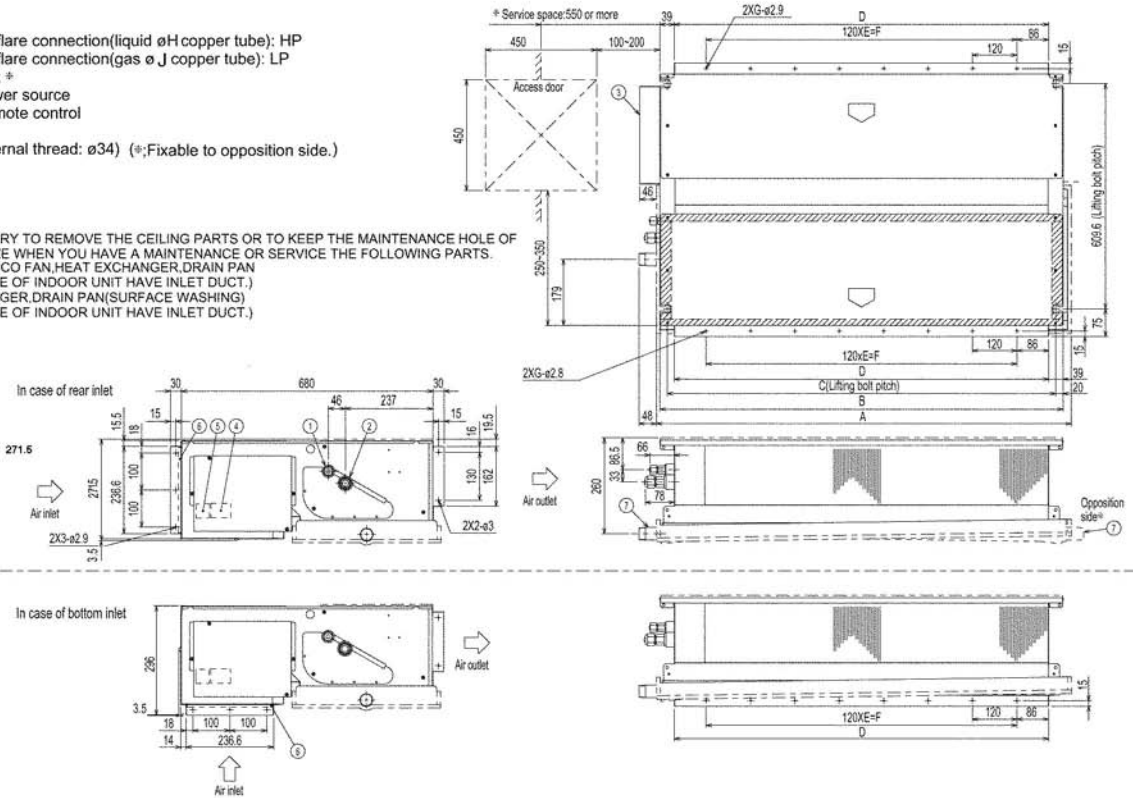

Model	A	B	C	D	E	F	G	H	J
RP60	1125	1090	1050	1012	7	840	8	Outdoor unit(SUZ) : 6.35 Other outdoor unit : 9.52 *	15.88
RP71	1125	1090	1050	1012	7	840	8	9.52	15.88
RP100	1365	1330	1290	1252	9	1080	10	9.52	R410A Outdoor unit : 15.88 * R407C Outdoor unit : 19.05

* Initial setting

<Accessory>
 Pipe cover.....2pcs.
 (For dew condensation prevention of local piping and unit connection)
 Remote controller.....1pc.

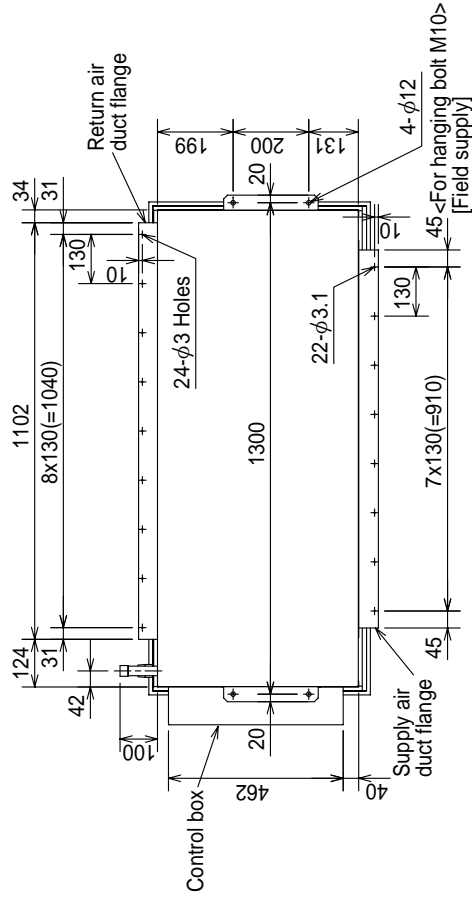
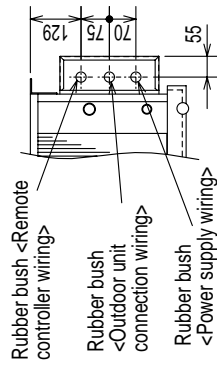

Top view

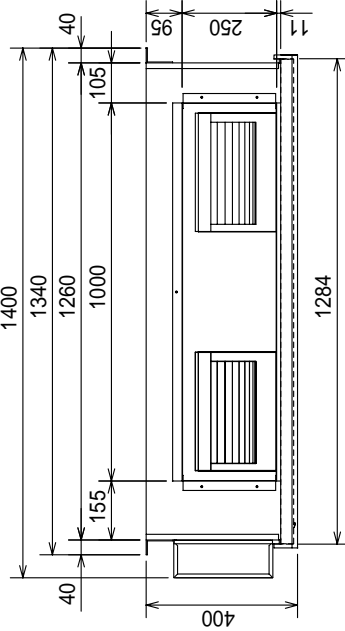

Front view

A

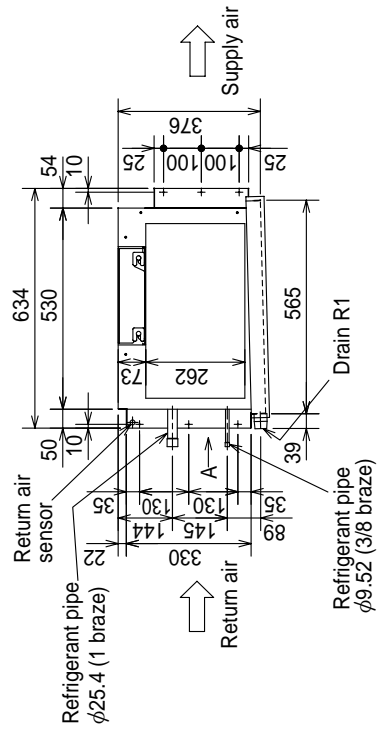

Left side view

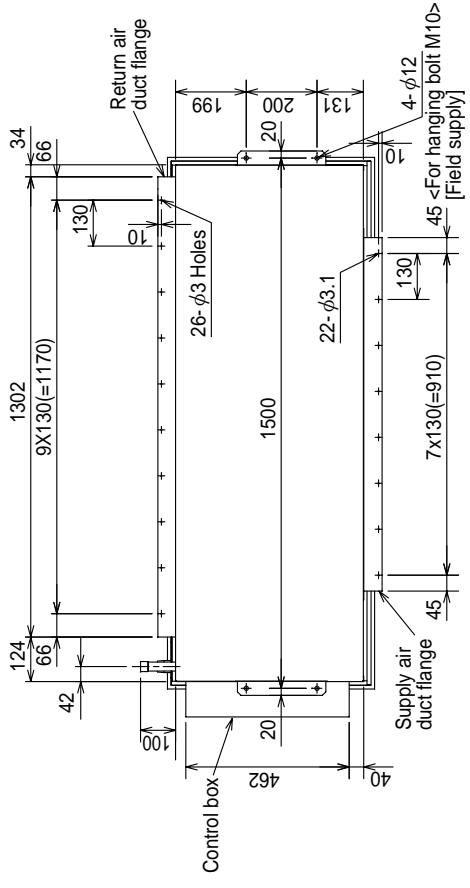

Top view

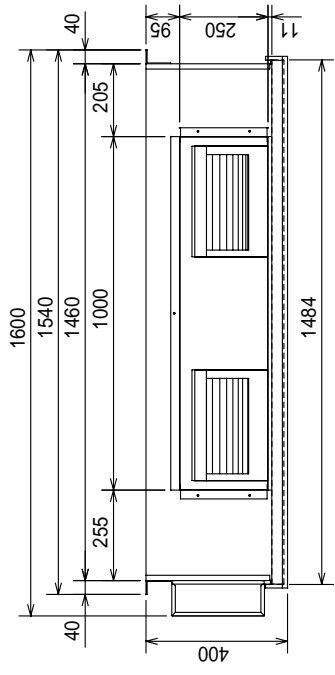

Front view

<Accessory>
 Pipe cover.....2pcs.
 (For dew condensation prevention of local piping and unit connection)
 Remote controller.....1pc.

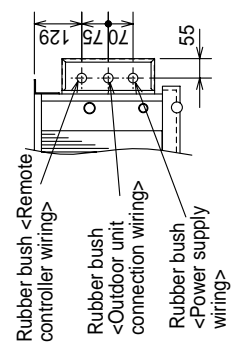

A

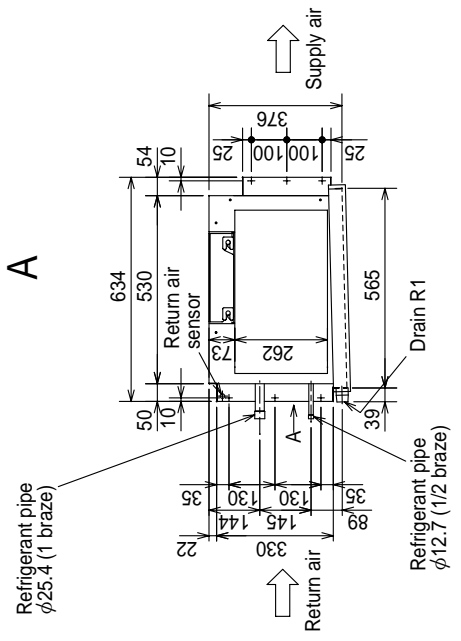

Left side view

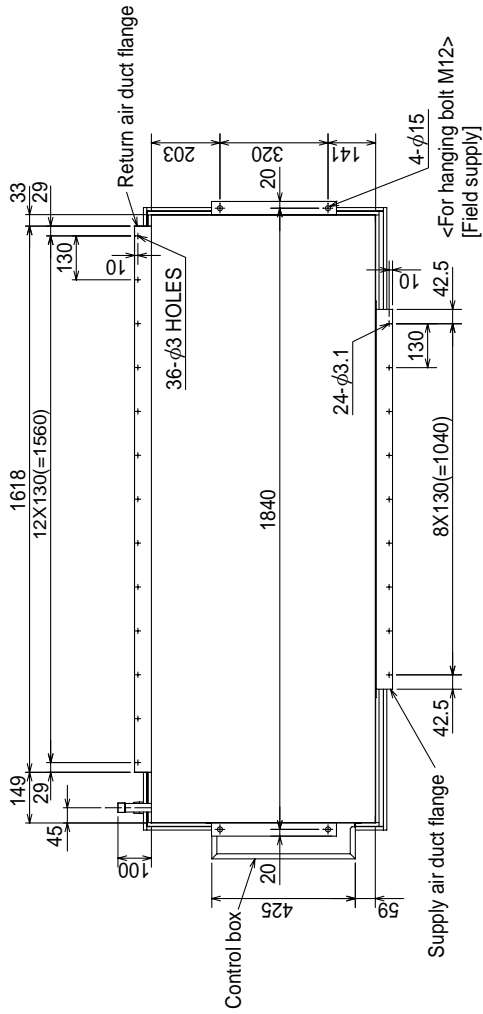

Top view

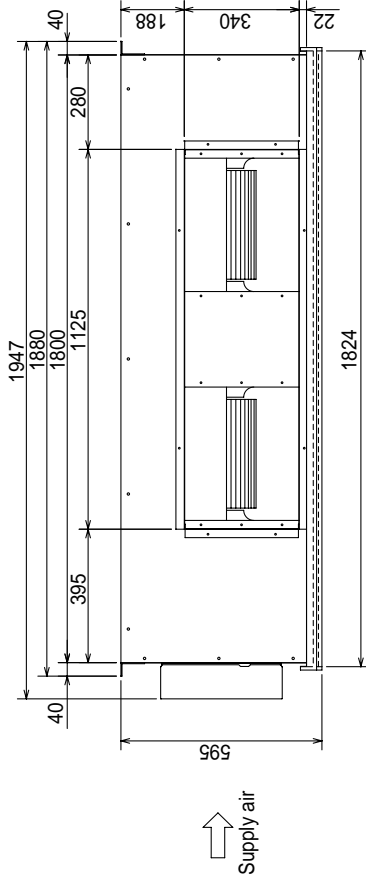

Front view

<Accessory>
 Pipe cover.....4pcs.
 (For dew condensation prevention of local piping and unit connection)
 Remote controller.....1pc.

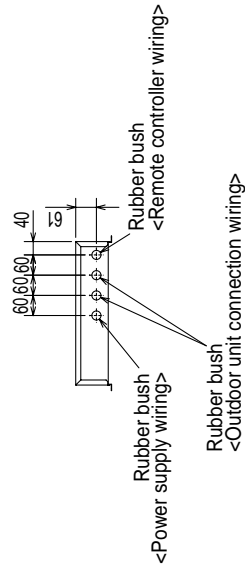

A

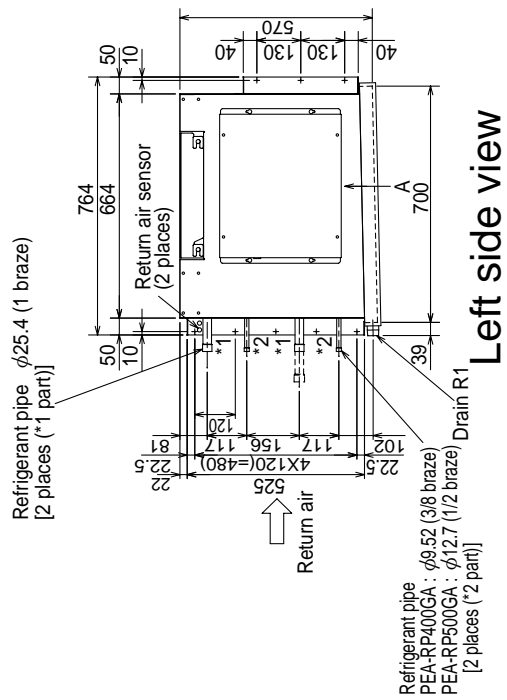

Left side view

PKA-RP50GAL

Unit : mm

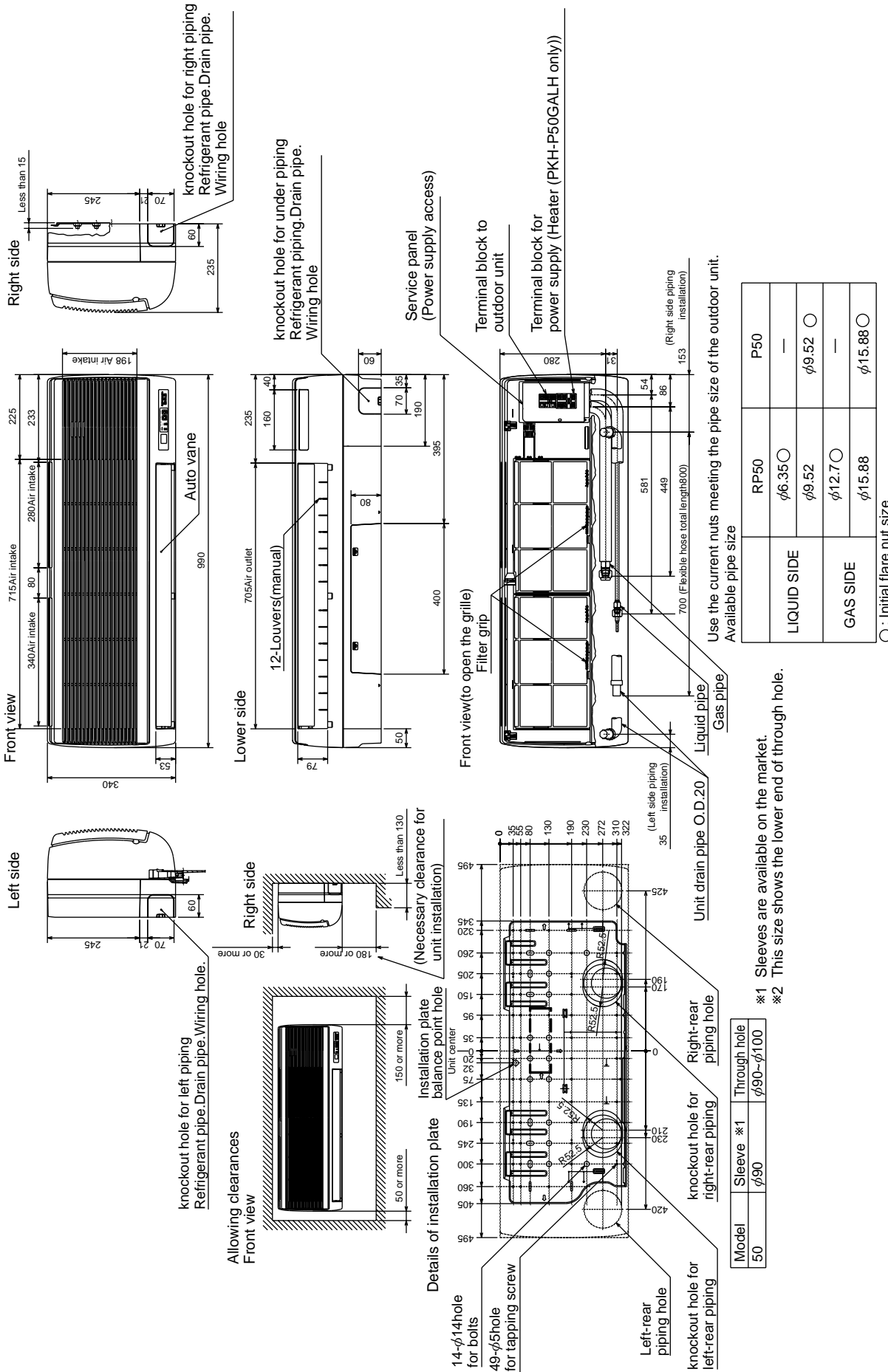

PKA-RP50FAL2
PKA-RP60FAL
PKA-RP71FAL

Unit : mm

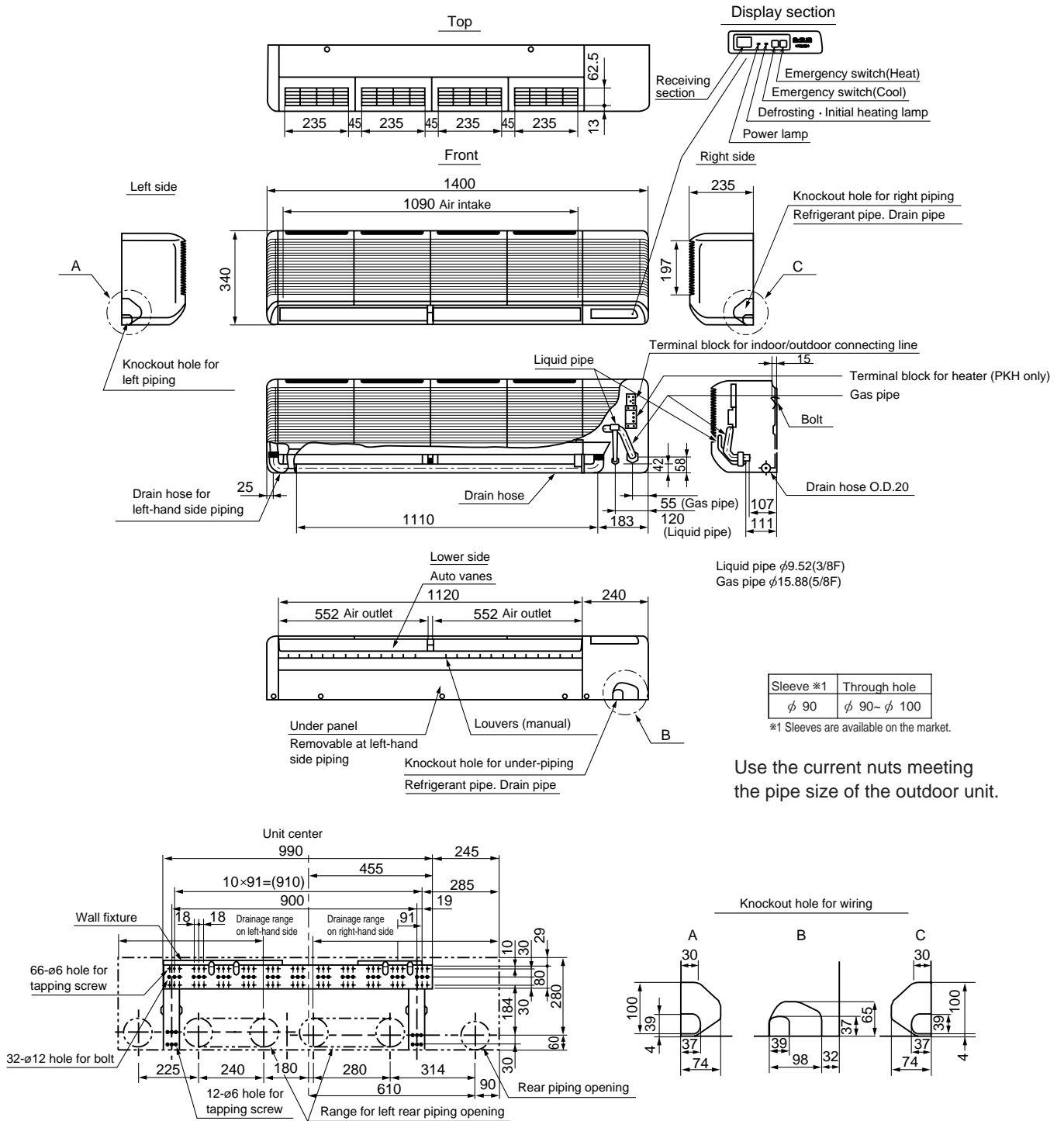

Available pipe size

	RP50	RP60,71 / P60,71
LIQUID SIDE	φ 6.35 ○	—
	φ 9.52	φ 9.52 ○
GAS SIDE	φ 12.7 ○	—
	φ 15.88	φ 15.88 ○

○:Initial flare nut size

PKA-RP100FAL

Unit : mm

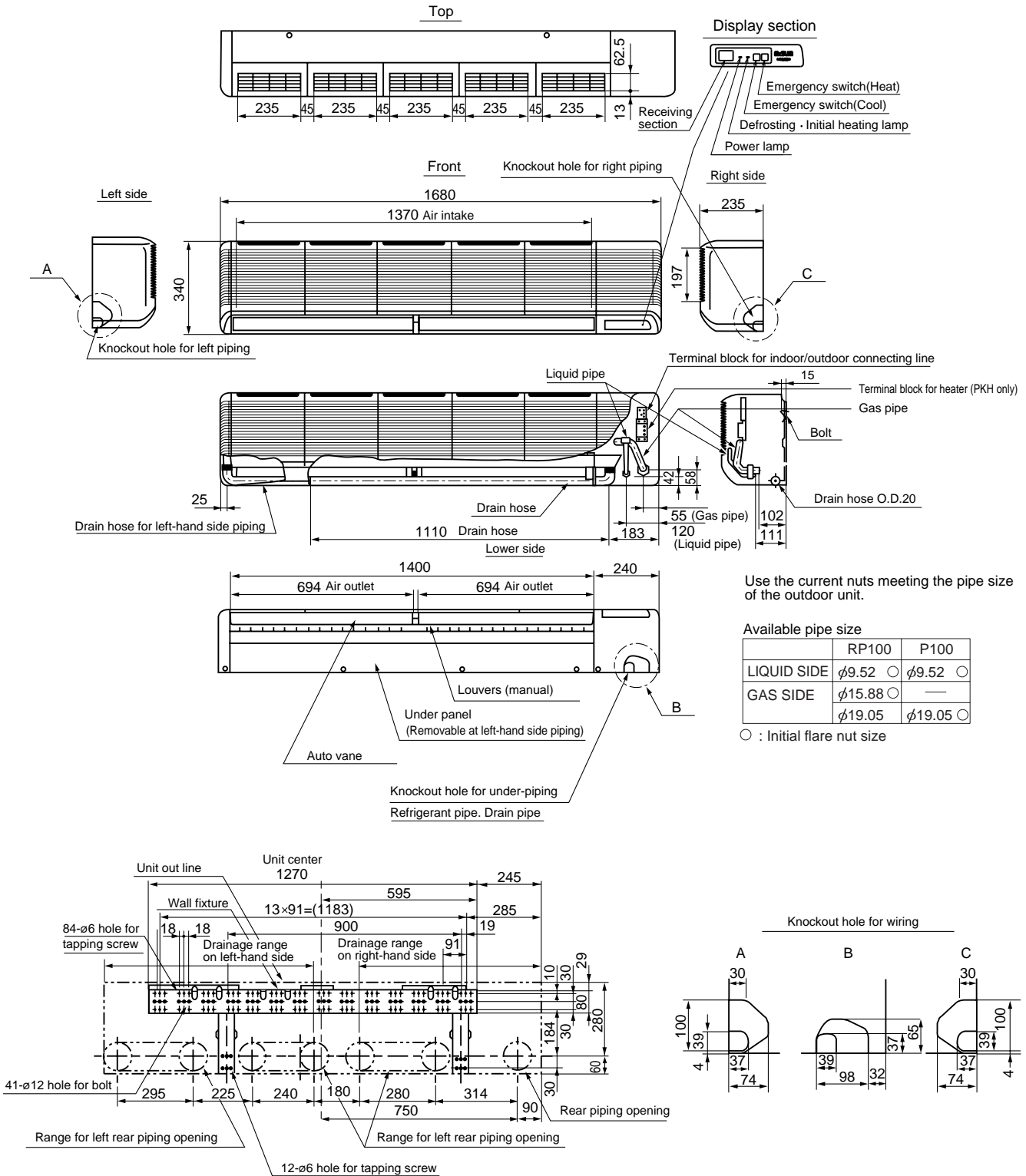

PCA-RP50GA

Unit : mm

NOTES:

1. Use M10 or W3/8 screws for anchor bolt.
2. When optional drain lift-up mechanism is installed, always provide upward piping for refrigerant piping.

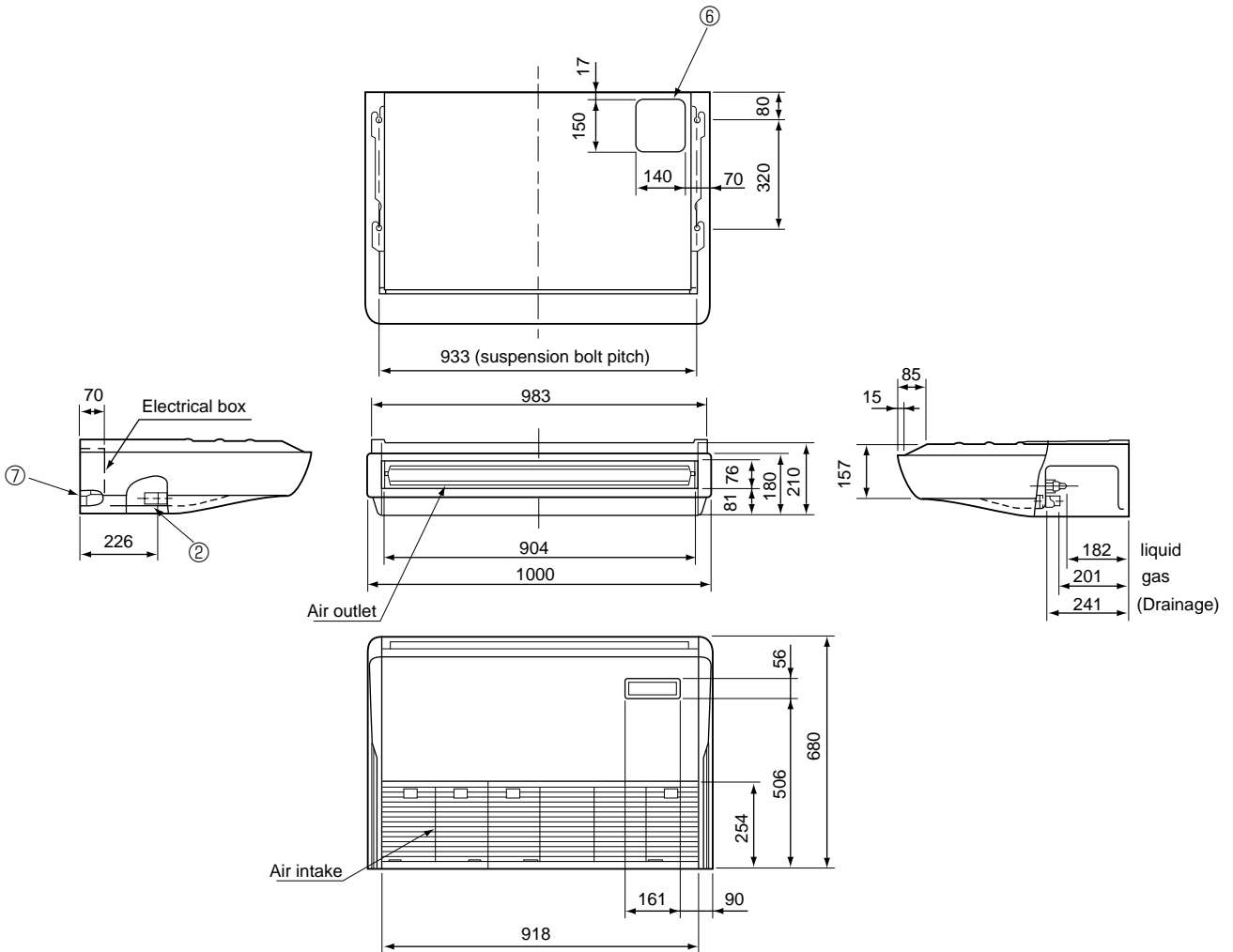

- ① Drainage pipe connection (26mm I.D.)
- ② Drainage pipe connection (for the left arrangement)
- ③ Knockout hole for left drain-piping arrangement
- ④ Refrigerant-pipe connection (gas pipe side/flared connection)
- ⑤ Refrigerant-pipe connection (liquid pipe side/flared connection)
- ⑥ Knockout hole for upper drain pipe arrangement
- ⑦ Knockout hole for left drain pipe arrangement
- ⑧ Knockout hole for wiring arrangement

Use the current nuts meeting the pipe size of the outdoor unit.

Available pipe size

	RP50	P50
⑥ LIQUID SIDE	$\phi 6.35$ ○	—
	$\phi 9.52$	$\phi 9.52$ ○
④ GAS SIDE	$\phi 12.7$ ○	—
	$\phi 15.88$	$\phi 15.88$ ○

○ : Initial flare nut size

PCA-RP50GA2
PCA-RP60GA
PCA-RP71GA

Unit : mm

NOTES:

1. Use M10 or W3/8 screws for anchor bolt.
2. When optional drain lift-up mechanism is installed, always provide upward piping for refrigerant piping.

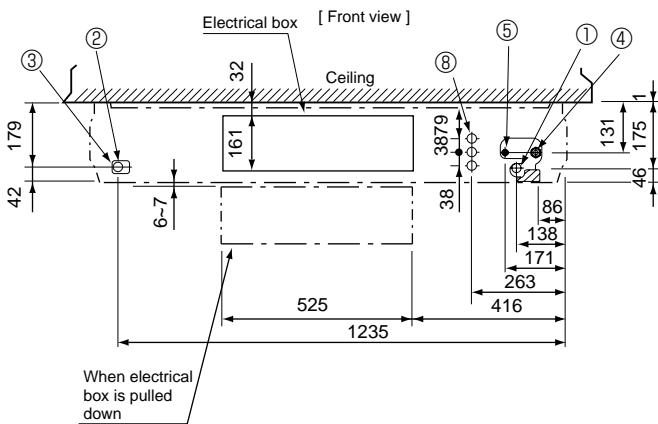
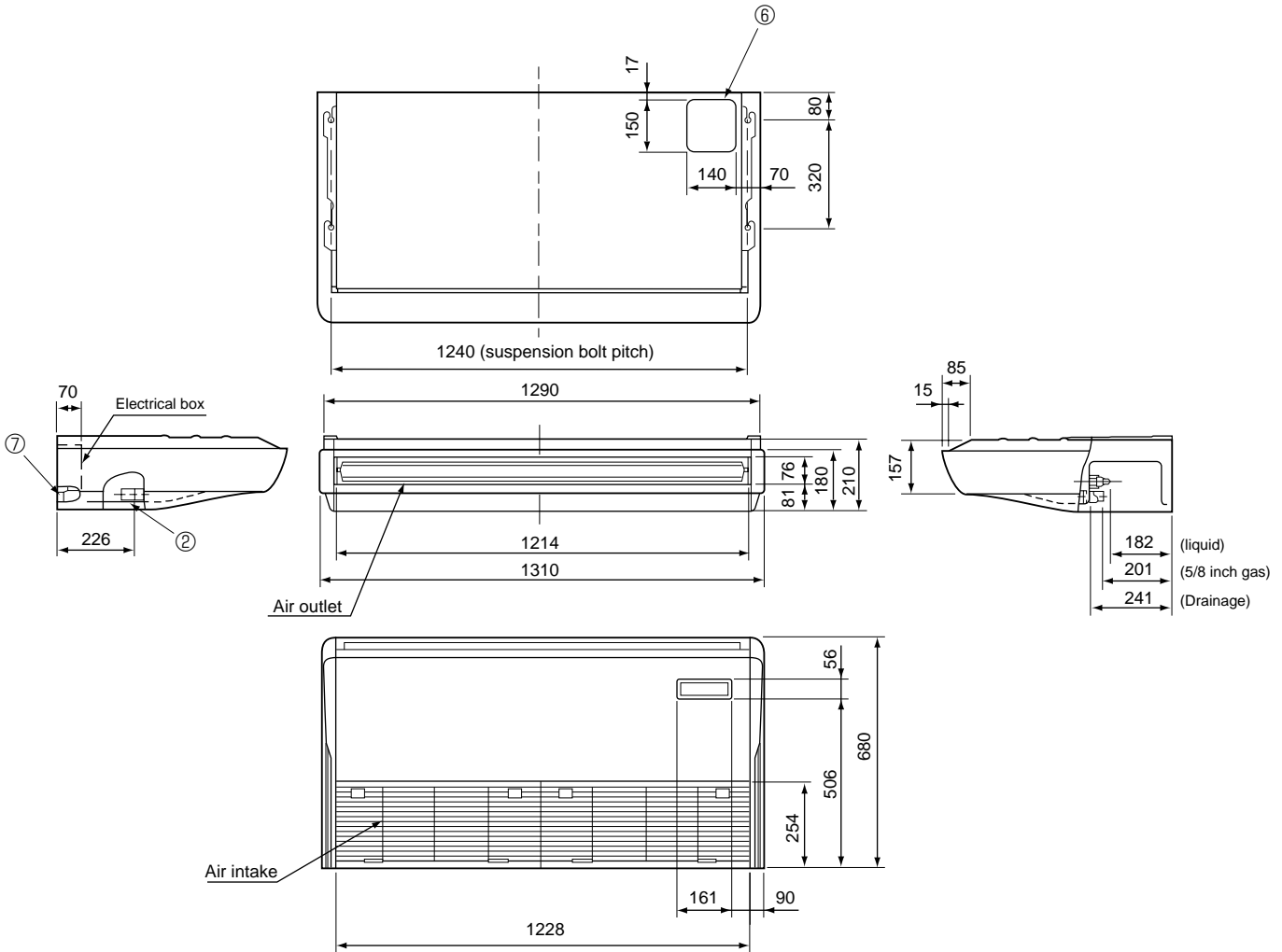

- ① Drainage pipe connection (26mm I.D.)
- ② Drainage pipe connection (for the left arrangement)
- ③ Knockout hole for left drain-piping arrangement
- ④ Refrigerant-pipe connection (gas pipe side/flared connection)
- ⑤ Refrigerant-pipe connection (liquid pipe side/flared connection)
- ⑥ Knockout hole for upper drain pipe arrangement
- ⑦ Knockout hole for left drain pipe arrangement
- ⑧ Knockout hole for wiring arrangement

Use the current nuts meeting the pipe size of the outdoor unit.

Available pipe size

	RP50	RP60	RP71,P60,P71
⑤ LIQUID SIDE	$\phi 6.35$ ○	$\phi 6.35$	—
	$\phi 9.52$	$\phi 9.52$ ○	$\phi 9.52$ ○
④ GAS SIDE	$\phi 12.7$ ○	—	—
	$\phi 15.88$	$\phi 15.88$ ○	$\phi 15.88$ ○
	—	—	—

○ : Initial flare nut size

PCA-RP100GA

Unit : mm

- NOTES:
1. Use M10 or W3/8 screws for anchor bolt.
 2. When optional drain lift-up mechanism is installed, always provide upward piping for refrigerant piping.

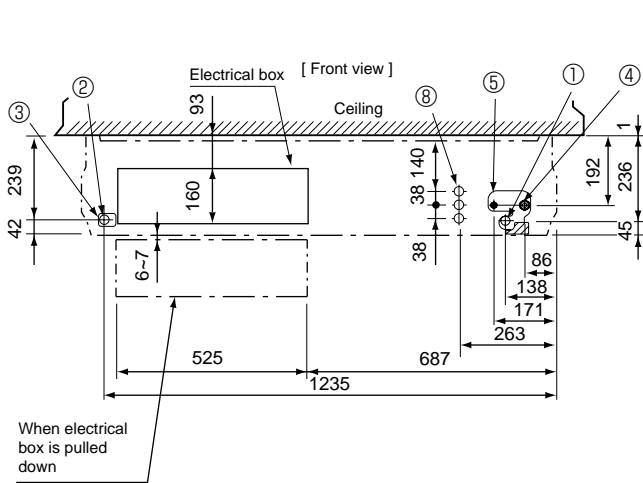
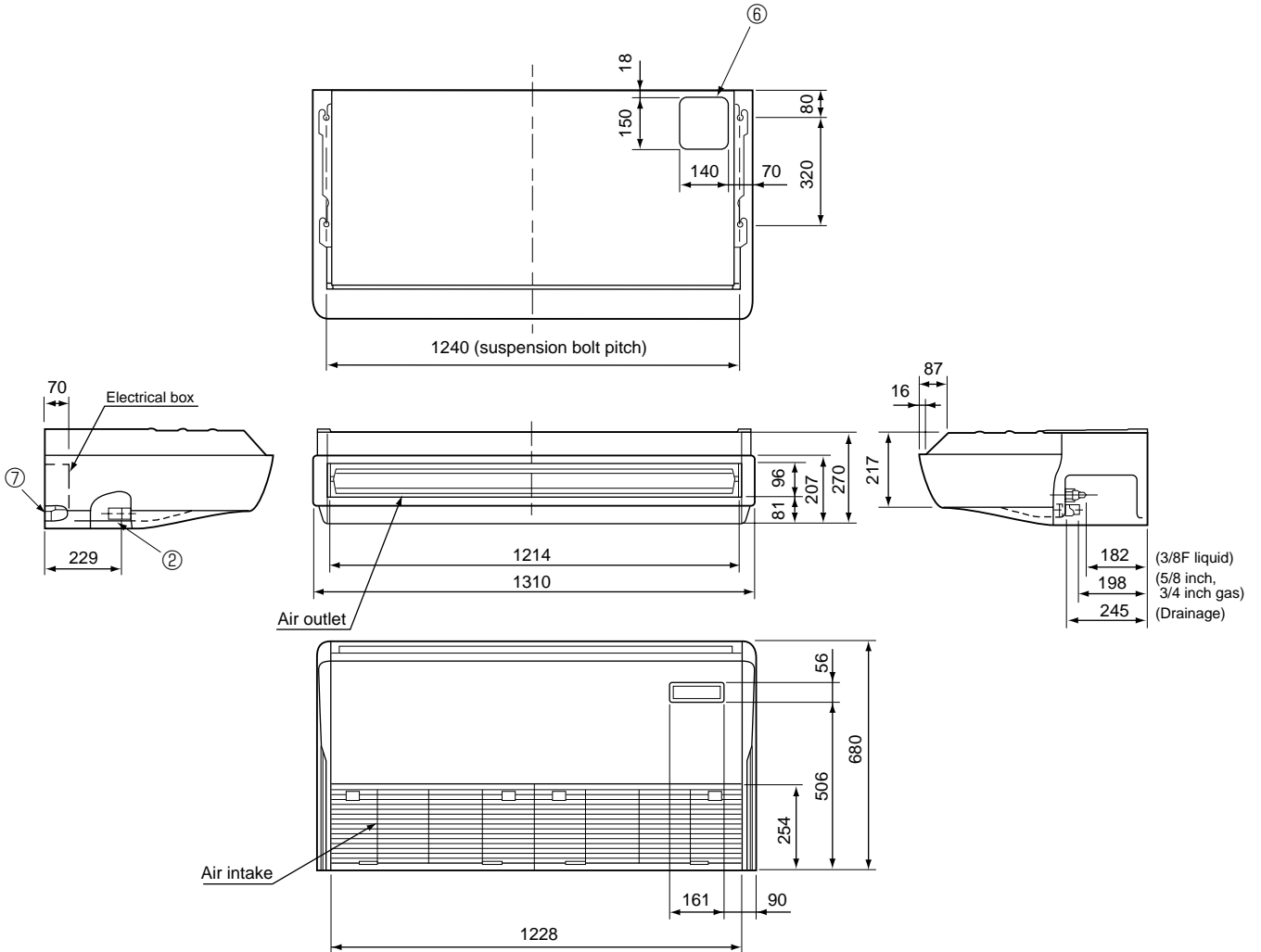

- 1 Drainage pipe connection (26mm I.D.)
- 2 Drainage pipe connection (for the left arrangement)
- 3 Knockout hole for left drain-piping arrangement
- 4 Refrigerant-pipe connection (gas pipe side/flared connection)
- 5 Refrigerant-pipe connection (liquid pipe side/flared connection)
- 6 Knockout hole for upper drain pipe arrangement
- 7 Knockout hole for left drain pipe arrangement
- 8 Knockout hole for wiring arrangement

Use the current nuts meeting the pipe size of the outdoor unit.

Available pipe size

	RP100	P100
⑤ LIQUID SIDE	—	—
	φ9.52 ○	φ9.52 ○
④ GAS SIDE	—	—
	φ15.88 ○	—
	φ19.05	φ19.05 ○

○ :Initial flare nut size

**PCA-RP125GA
PCA-RP140GA**

Unit : mm

NOTES:

1. Use M10 or W3/8 screws for anchor bolt.
2. When optional drain lift-up mechanism is installed, always provide upward piping for refrigerant piping.

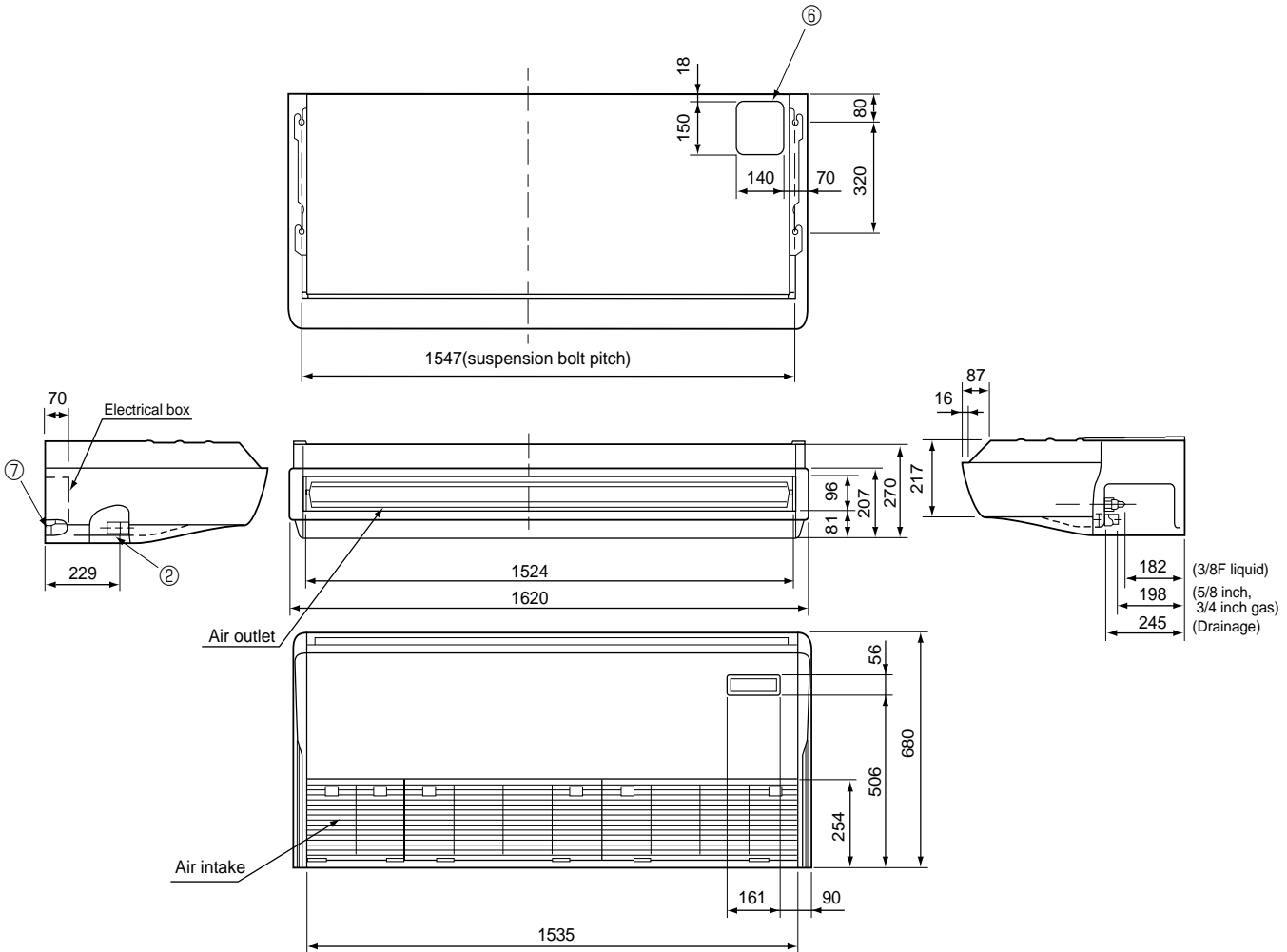

- ① Drainage pipe connection (26mm I.D.)
- ② Drainage pipe connection (for the left arrangement)
- ③ Knockout hole for left drain-piping arrangement
- ④ Refrigerant-pipe connection (gas pipe side/flared connection)
- ⑤ Refrigerant-pipe connection (liquid pipe side/flared connection)
- ⑥ Knockout hole for upper drain pipe arrangement
- ⑦ Knockout hole for left drain pipe arrangement
- ⑧ Knockout hole for wiring arrangement

Use the current nuts meeting the pipe size of the outdoor unit.

Available pipe size

	RP125,140	P125,140
⑤ LIQUID SIDE	—	—
	φ9.52 ○	φ9.52 ○
④ GAS SIDE	—	—
	φ15.88 ○	—
	φ19.05	φ19.05 ○

○ : Initial flare nut size

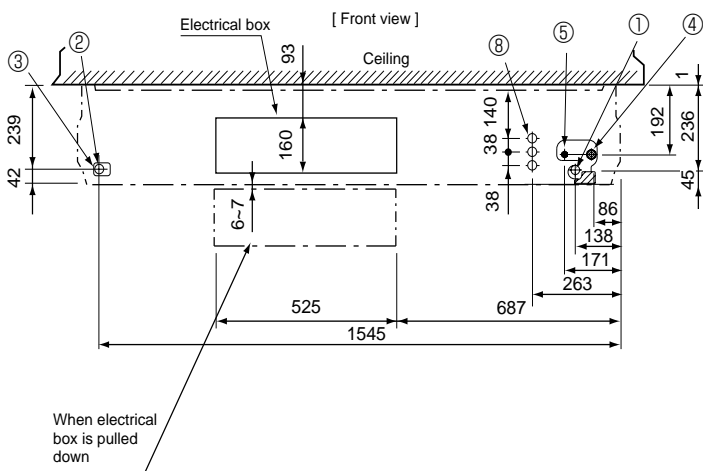

PCA-RP71HA

Unit : mm

- ① Refrigerant-pipe connection(gas pipe side/flared connection : 5/8 inch)
 - ② Refrigerant-pipe connection(liquid pipe side/flared connection : 3/8 inch)
 - ③ Flexible hose(accessory) → Drainage pipe connection(26mm I.D.)
 - ④ Knockout hole for behind refrigerant-piping arrangement
 - ⑤ Knockout hole for upper refrigerant-pipe arrangement
 - ⑥ Knockout hole for wiring arrangement : 2- ϕ 27
 - ⑦ Terminal block(indoor/outdoor connecting line)
 - ⑧ Terminal block(remote controller)
 - ⑨ Knockout hole (duct for fresh air intake): 2- ϕ 200
- Optional parts:duct flange(ϕ 200). model: PAC-SF28OF-E(1 pc.)

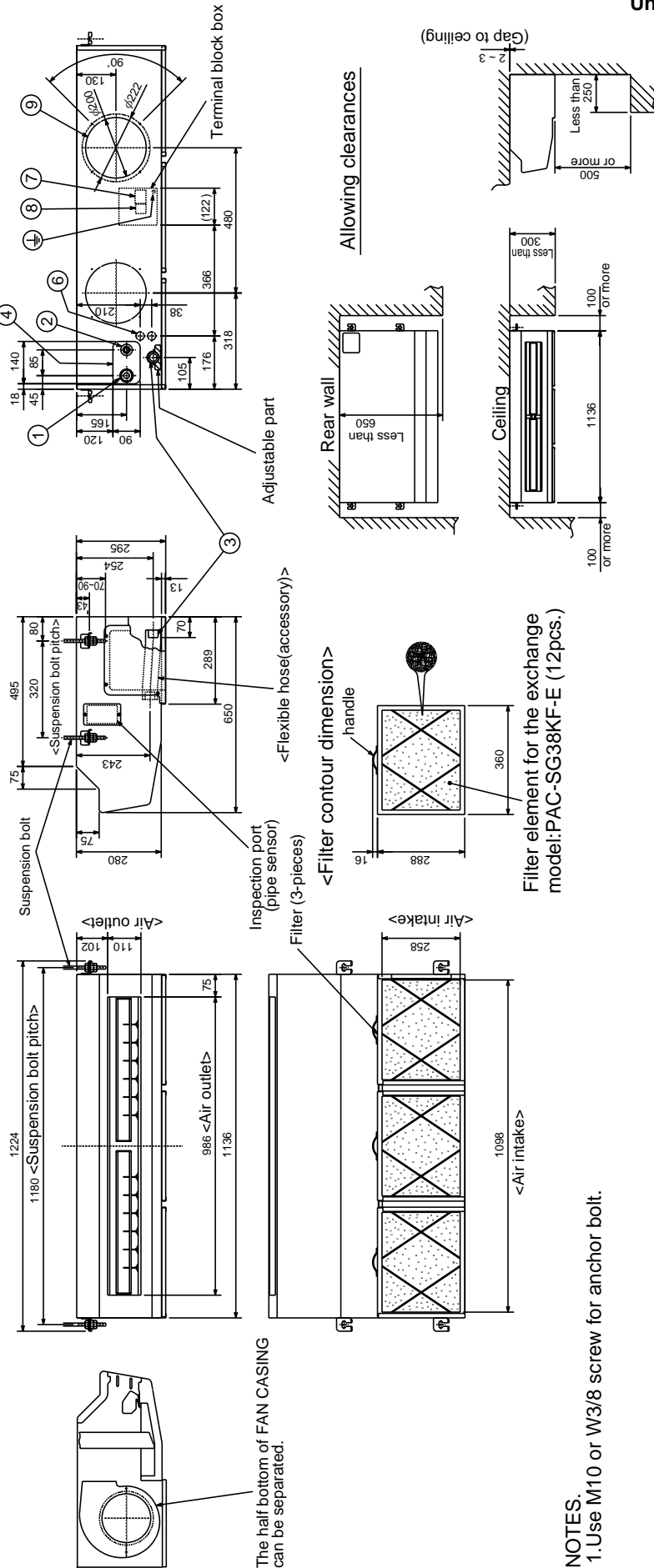
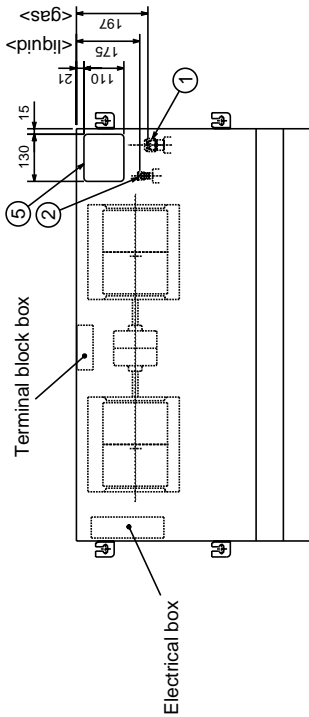

NOTES.
1. Use M10 or W3/8 screw for anchor bolt.

PCA-RP125HA

Unit : mm

- ① Refrigerant-pipe connection(gas pipe side/flared connection : 5/8 inch, 3/4 inch)
 - ② Refrigerant-pipe connection(liquid pipe side/flared connection : 3/8 inch)
 - ③ Flexible hose(accessory)→ Drainage pipe connection(26mm I.D.)
 - ④ Knockout hole for behind refrigerant-piping arrangement
 - ⑤ Knockout hole for upper refrigerant-pipe arrangement
 - ⑥ Knockout hole for wiring arrangement : 2-φ 27
 - ⑦ Terminal block(indoor/outdoor connecting line)
 - ⑧ Terminal block(remote controller)
 - ⑨ Knockout hole (duct for fresh air intake) : 2-φ 200
- Optional parts:duct flange(φ 200). model: PAC-SF280F-E(1 pc.)

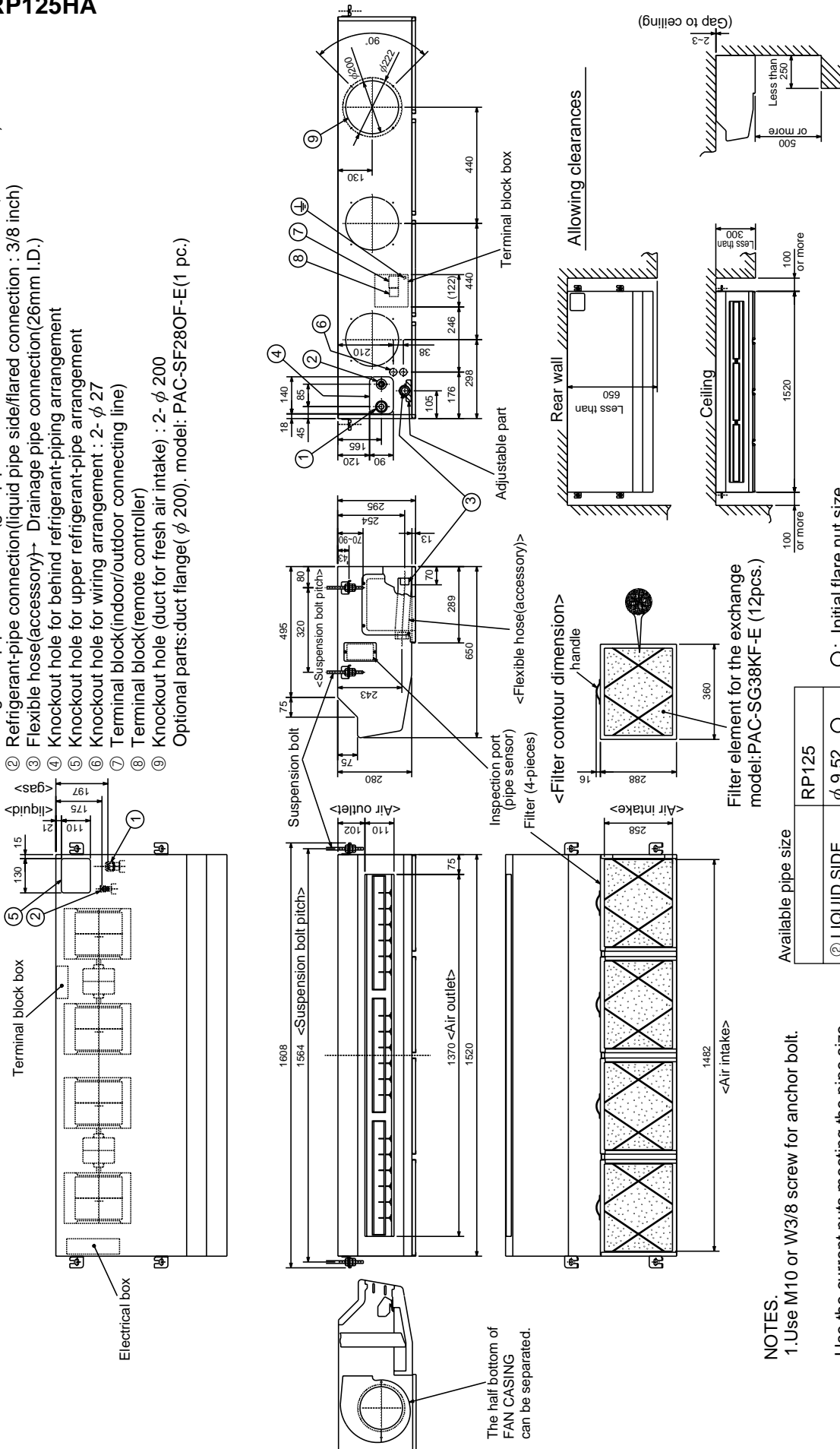

Filter element for the exchange
model:PAC-SG38KF-E (12pcs.)

Available pipe size	RP125
② LIQUID SIDE	φ 9.52 ○
① GAS SIDE	φ 15.88 ○
	φ 19.05 ○

NOTES.
1. Use M10 or W3/8 screw for anchor bolt.
Use the current nuts meeting the pipe size of the outdoor unit.

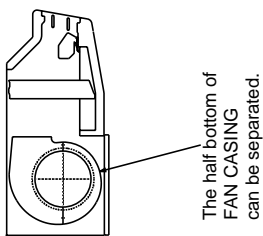

PSA-RP71GA

Unit : mm

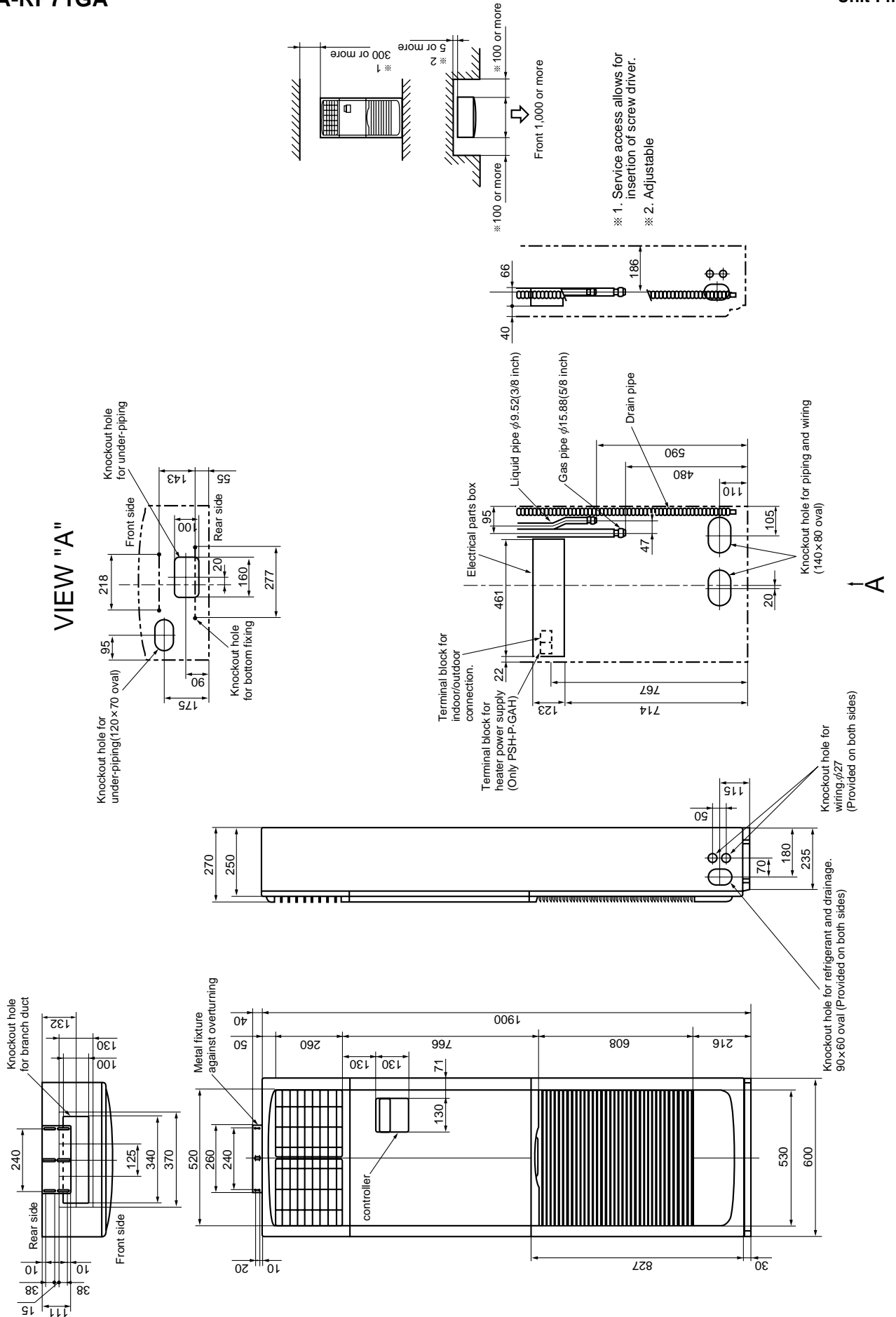

**PSA-RP100GA
PSA-RP125GA
PSA-RP140GA**

Unit : mm

Use the current nuts meeting the pipe size of the outdoor unit.

Available pipe size

	RP100,125,140	P100,125,140
LIQUID SIDE	φ 9.52 ○	φ 9.52 ○
GAS SIDE	φ 15.88 ○	φ 19.05 ○

○ : Initial flare nut size

VIEW "A"

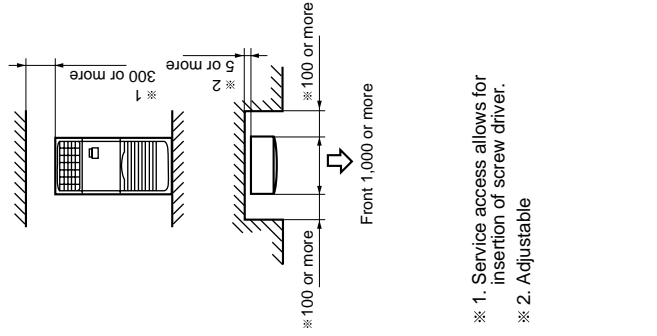
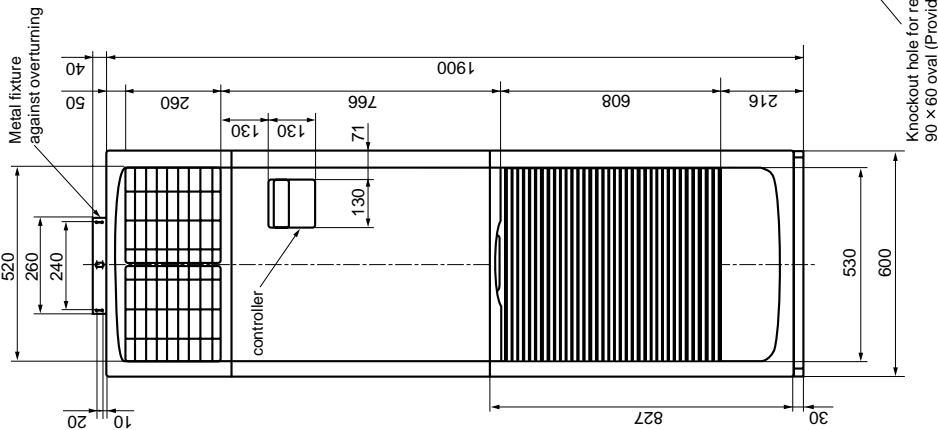
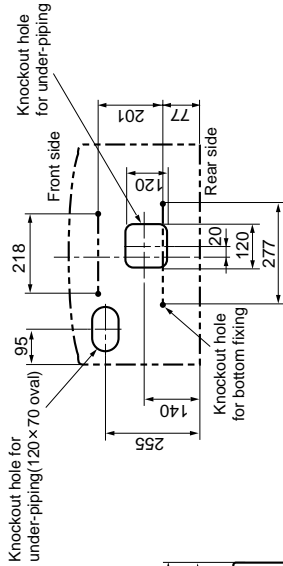
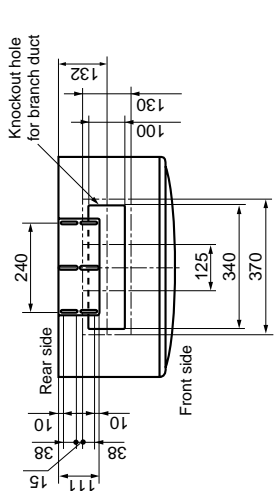

- ※ 1. Service access allows for insertion of screw driver.
- ※ 2. Adjustable

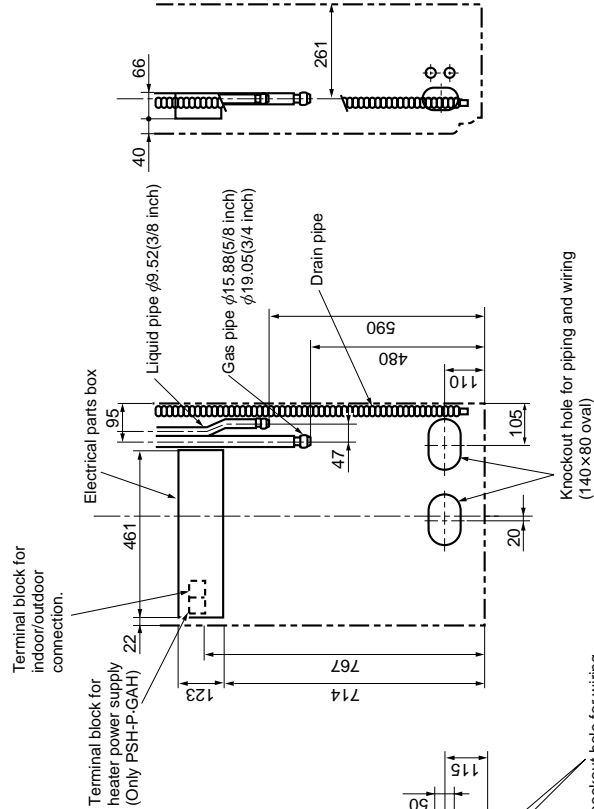

A

PUHZ-P125VHA2
PUHZ-P140VHA2

Unit : mm

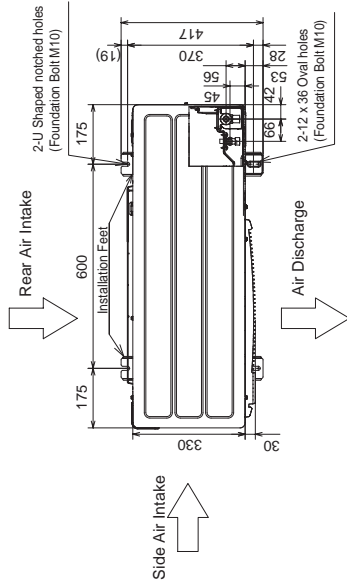

4 PIPING-WIRING DIRECTIONS

Piping and wiring connections can be made from 4 directions: front, right, rear and below.

3 FOUNDATION BOLTS

Please secure the unit firmly with 4 foundation (M10) bolts. (Bolts and washers must be purchased locally.)

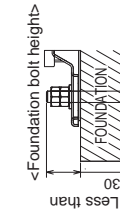

2 SERVICE SPACE

Dimensions of space needed for service access are shown in the below diagram.

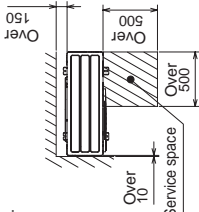

1 FREE SPACE (Around the unit)

The diagram below shows a basic example. Explanation of particular details are given in the installation manuals etc.

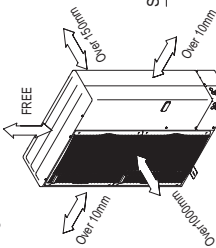

Example of Notes

- ①...Refrigerant GAS pipe connection (FLARE)φ15.88(5/8 inch)
- ②...Refrigerant LIQUID pipe connection (FLARE)φ 9.52(3/8 inch)
- *1 ...Indication of STOP VALVE connection location.

Piping Knockout Hole Details

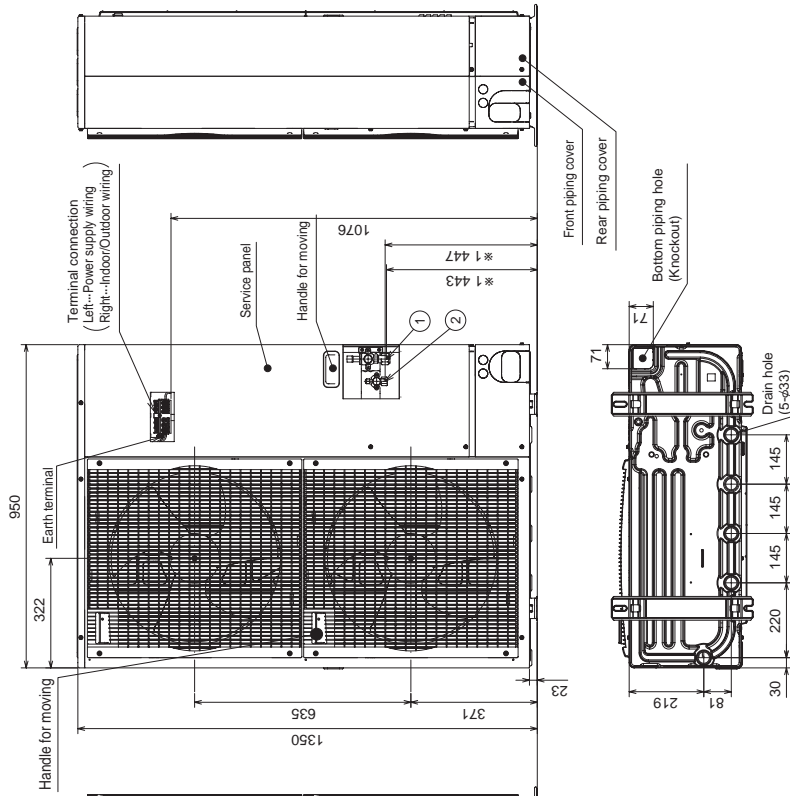
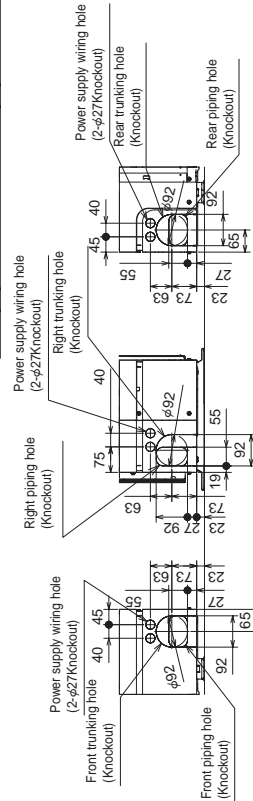

PUHZ-P200YHA PUHZ-P250YHA

Unit : mm

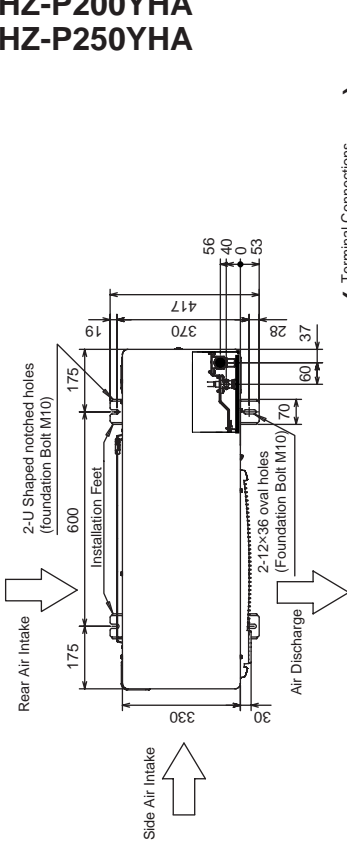

4 PIPING-WIRING DIRECTIONS

Piping and wiring connections can be made from 4 directions: front, right, rear and below.

3 FOUNDATION BOLTS

Please secure the unit firmly with 4 foundation (M10) bolts. (Bolts and washers must be purchased locally.)

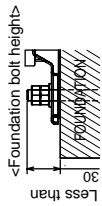

2 SERVICE SPACE

Dimensions of space needed for service access are shown in the below diagram.

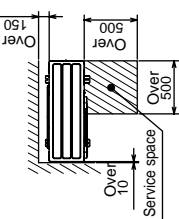

1 FREE SPACE (Around the unit)

The diagram below shows a basic example. Explanation of particular details are given in the installation manuals etc.

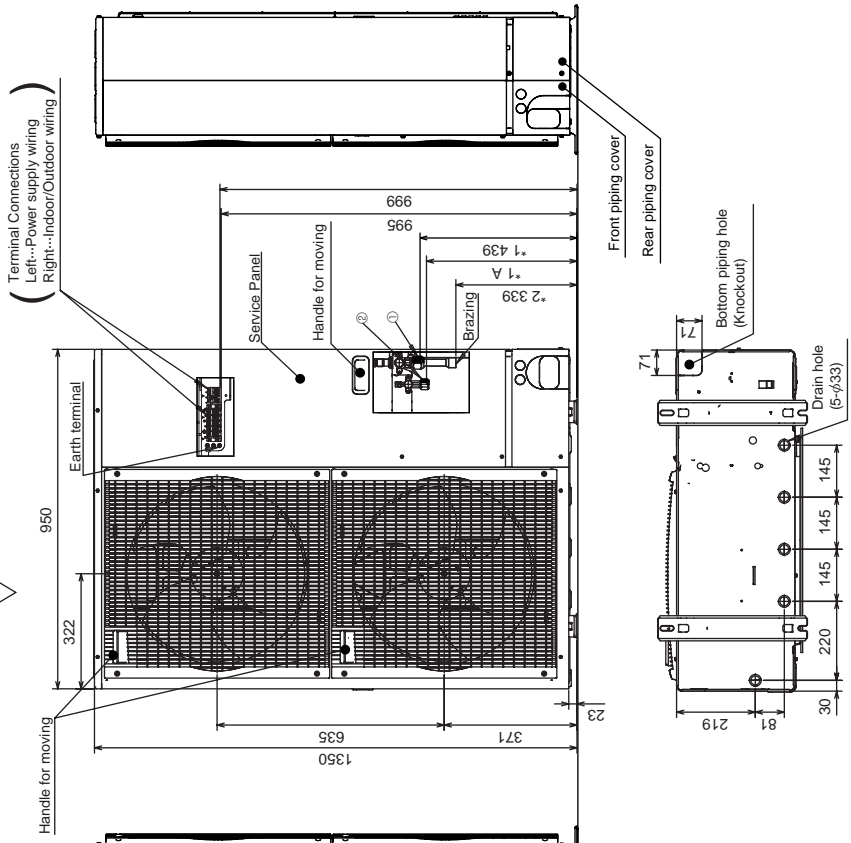
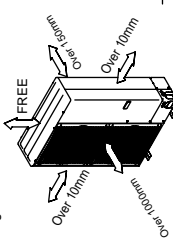

Example of Notes

- ①...Refrigerant GAS pipe connection (FLARE)(φ19.05(3/4) inch)
- ②...Refrigerant LIQUID pipe connection (FLARE)
- *1...Indication of STOP VALVE connection location
- *2...Refrigerant GAS PIPE connection(BRAZING) O. D.φ25.4

	②	A
PUHZ-P200YHA	φ9.52 (3/8 inch)	447
PUHZ-P250YHA	φ12.7 (1/2 inch)	421

Piping Knockout Hole Details

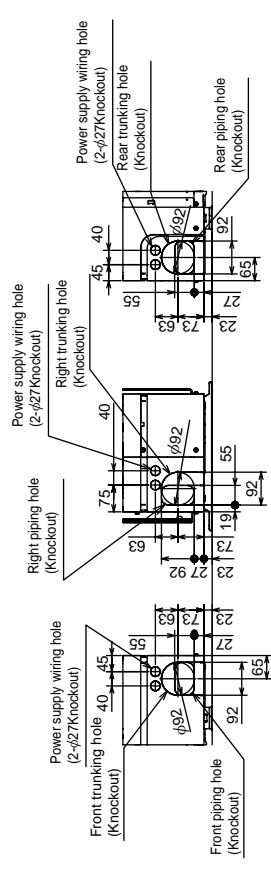



WIRED REMOTE CONTROLLER

Unit : mm

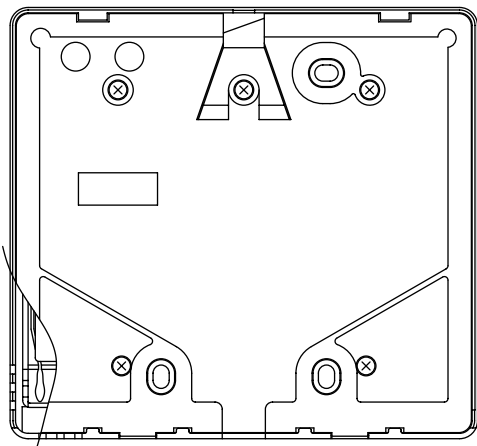
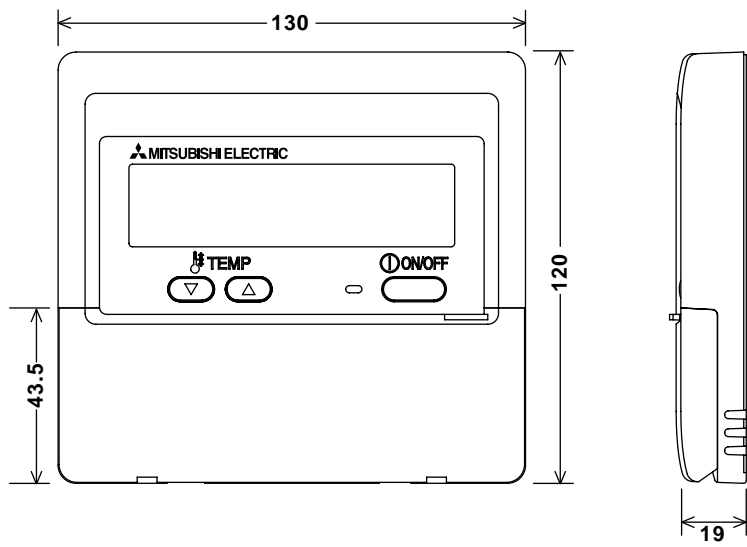



WIRELESS REMOTE CONTROLLER

Unit : mm

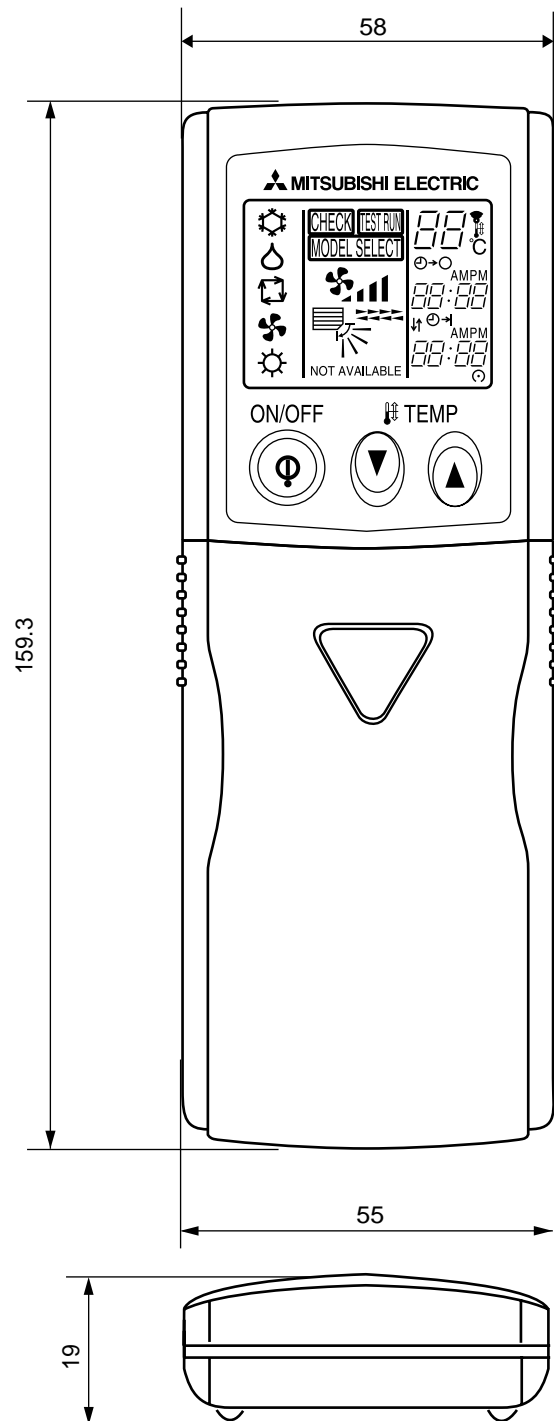

4

WIRING DIAGRAM

PLA-RP50BA
PLA-RP100BA

PLA-RP60BA
PLA-RP125BA

PLA-RP71BA
PLA-RP140BA

[LEGEND]

SYMBOL	NAME	SYMBOL	NAME
I.B	INDOOR CONTROLLER BOARD	MF	FAN MOTOR
CN2L	CONNECTOR (LOSSNAY)	MV	VANE MOTOR
CN32	CONNECTOR (REMOTE SWITCH)	TB2	TERMINAL BLOCK (Indoor unit Power (option))
CN41	CONNECTOR (HA TERMINAL-A)	TB4	TERMINAL BLOCK (INDOOR/OUTDOOR CONNECTING LINE)
CN51	CONNECTOR (CENTRALLY CONTROL)	TB5, TB6	TERMINAL BLOCK (REMOTE CONTROLLER TRANSMISSION LINE)
DSA	SURGE ABSORBER		
FUSE	FUSE (T6.3AL250V)	TH1	ROOM TEMP. THERMISTOR (0°C / 15kΩ, 25°C / 5.4kΩ DETECT)
LED1	POWER SUPPLY (I.B)	TH2	PIPE TEMP. THERMISTOR/LIQUID (0°C / 15kΩ, 25°C / 5.4kΩ DETECT)
LED2	POWER SUPPLY (R.B)	TH5	COND. / EVA. TEMP. THERMISTOR (0°C / 15kΩ, 25°C / 5.4kΩ DETECT)
LED3	TRANSMISSION (INDOOR-OUTDOOR)		
SW1	SWITCH (MODEL SELECTION) *See table 1		
SW2	SWITCH (CAPACITY CODE) *See table 2		
SWE	CONNECTOR (EMERGENCY OPERATION)	OPTION PART	
X1	RELAY (DRAIN PUMP)	W.B	PCB FOR WIRELESS REMOTE CONTROLLER
ZNR01,02	VARISTOR	BZ	BUZZER
DCL	REACTOR	LED1	LED (OPERATION INDICATION : GREEN)
DP	DRAIN-UP MACHINE	LED2	LED (PREPARATION FOR HEATING : ORANGE)
FS	DRAIN FLOAT SWITCH	RU	RECEIVING UNIT
		SW1	EMERGENCY OPERATION (HEAT / DOWN)
		SW2	EMERGENCY OPERATION (COOL / UP)

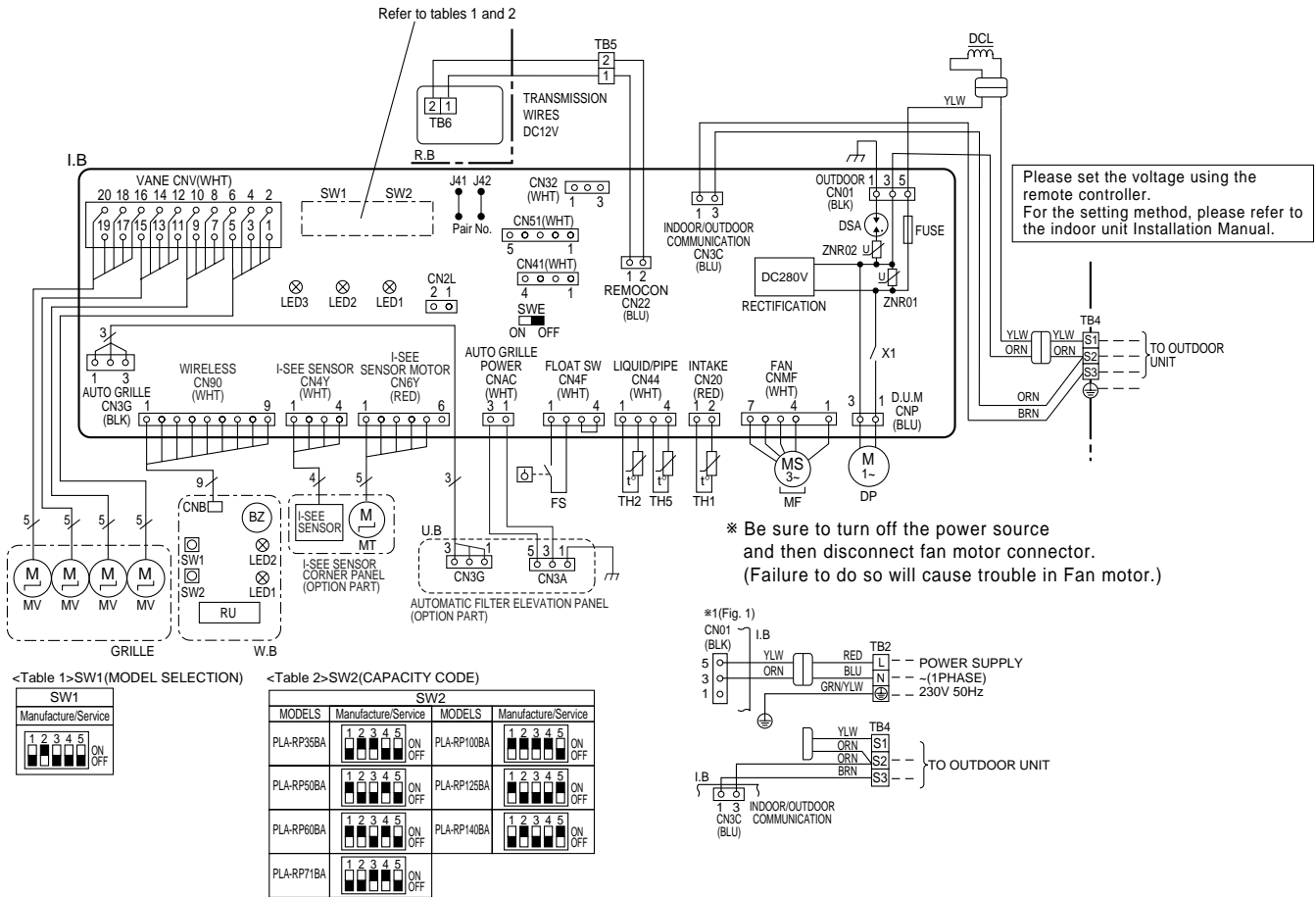

Notes:

1. Symbols used in wiring diagram above are, : Connector, : Terminal (block).
 2. Indoor and outdoor connecting wires have polarities, make sure to match terminal numbers (S1, S2, S3) for correct wirings.
 3. Since the outdoor side electric wiring may change, be sure to check the outdoor unit electric wiring diagram for servicing.
 4. This diagram shows the wiring of indoor and outdoor connecting wires (specification of 230V), adopting superimposed system of power and signal.
- *1: When work to supply power separately to indoor and outdoor units was applied, refer to Fig 1.
*2: For power supply system of this unit, refer to the caution label located near this diagram.

PEAD-RP50EA PEAD-RP60EA PEAD-RP71EA
PEAD-RP100EA2 PEAD-RP125EA PEAD-RP140EA

LEGEND

SYMBOL	NAME	SYMBOL	NAME	SYMBOL	NAME
I.B.	INDOOR CONTROLLER BOARD	SW2	SWITCH(CAPACITY CORD)	TB4	TERMINAL BLOCK (INDOOR/OUTDOOR CONNECTING LINE)
FUSE	FUSE(T6.3AL250V)	SWE	SWITCH(EMERGENCY OPERATION)	TB5	TERMINAL BLOCK(REMOTE CONTROLLER)
ZNR	VARIATOR	X1	RELAY(DRAIN PUMP)	TH1	INTAKE AIR TEMP. THERMISTOR (0°C /15kΩ,25°C/5.4kΩ DETECT)
CN2L	CONNECTOR(LOSSNAY)	X4	RELAY(FAN MOTOR)	TH2	PIPE TEMP. THERMISTOR/LIQUID (0°C /15kΩ,25°C/5.4kΩ DETECT)
CN24	CONNECTOR(HEATER)	X5	RELAY(FAN MOTOR)	TH5	COND./EVA. TEMP. THERMISTOR (0°C /15kΩ,25°C/5.4kΩ DETECT)
CN32	CONNECTOR(REMOTE SWITCH)	X6	RELAY(FAN MOTOR)		
CN41	CONNECTOR(HA TERMINAL-A)	P.B.	INDOOR POWER BOARD		
CN51	CONNECTOR(CENTRALLY CONTROL)	DRAIN PUMP	(OPTIONAL PARTS)		
CN90	CONNECTOR(WIRELESS)	DP	DRAIN PUMP		
LED1	POWER SUPPLY(L.B.)	DS	DRAIN SENSOR		
LED2	POWER SUPPLY(REMOTE CONTROLLER)	C	CAPACITOR(FAN MOTOR)		
LED3	TRANSMISSION(INDOOR•OUTDOOR)	MF	FAN MOTOR		
SW1	SWITCH(MODEL SELECTION)				

INSIDE SECTION OF CONTROL BOX

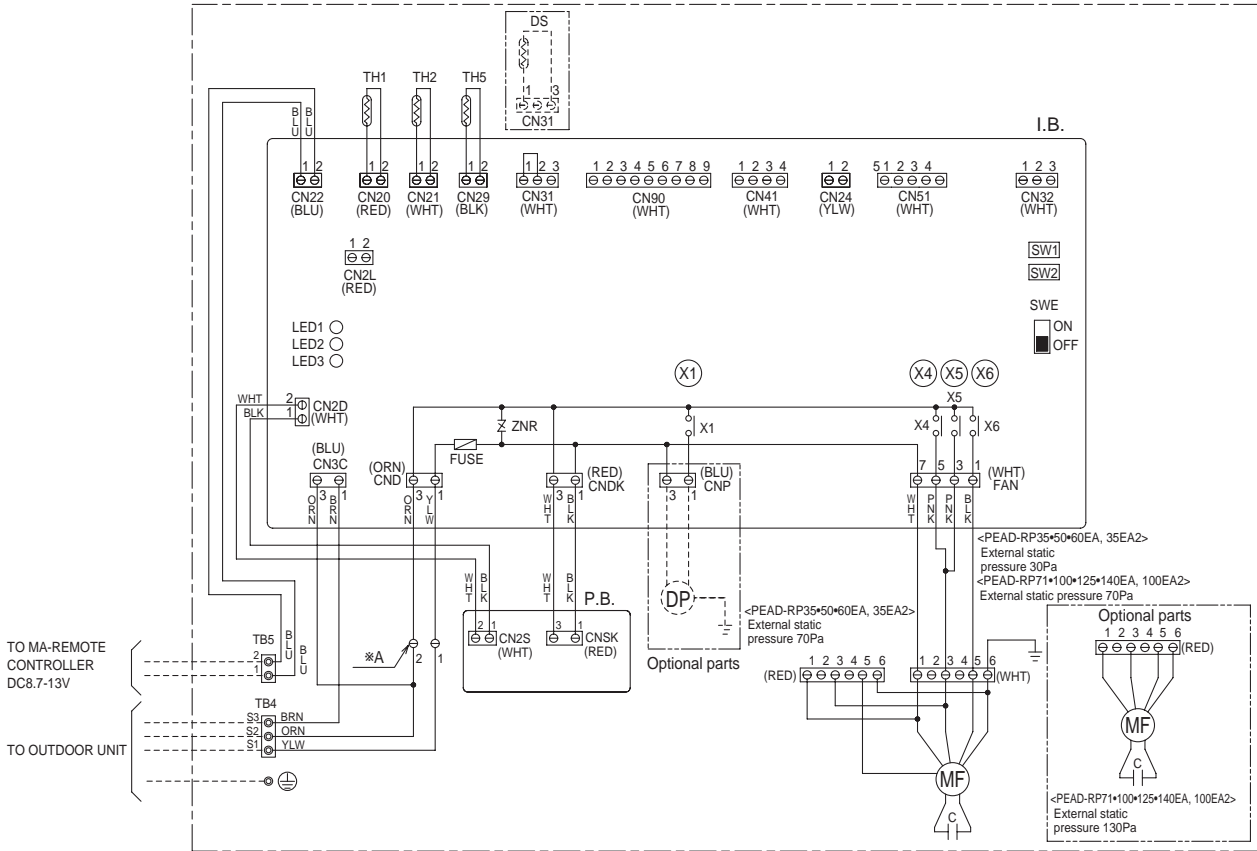

MODELS	SW1 Model selection switch	SW2 Capacity cord switch
35EA(2)	1 2 3 4 5 ON OFF	1 2 3 4 5 ON OFF
50EA	1 2 3 4 5 ON OFF	1 2 3 4 5 ON OFF
60EA	1 2 3 4 5 ON OFF	1 2 3 4 5 ON OFF
71EA	1 2 3 4 5 ON OFF	1 2 3 4 5 ON OFF
100EA(2)	1 2 3 4 5 ON OFF	1 2 3 4 5 ON OFF
125EA	1 2 3 4 5 ON OFF	1 2 3 4 5 ON OFF
140EA	1 2 3 4 5 ON OFF	1 2 3 4 5 ON OFF

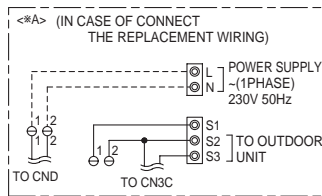

Notes:

- Symbols used in wiring diagram above are, : Connector, : Terminal (block).
- Indoor and outdoor connecting wires have polarities, make sure to match terminal numbers (S1, S2, S3) for correct wirings.
- Since the outdoor side electric wiring may change, be sure to check the outdoor unit electric wiring diagram for servicing.
- This diagram shows the wiring of indoor and outdoor connecting wires (specification of 230V), adopting superimposed system of power and signal.
 *1: When work to supply power separately to indoor and outdoor units was applied, refer to *A.
 *2: For power supply system of this unit, refer to the caution label located near this diagram.

PEAD-RP60GA PEAD-RP71GA PEAD-RP100GA

[LEGEND]

SYMBOL	NAME	SYMBOL	NAME	SYMBOL	NAME
I.B.	INDOOR CONTROLLER BOARD	SW1	SWITCH(MODEL SELECTION)	TB5	TERMINAL BLOCK(REMOTE CONTROLLER)
FUSE	FUSE(T6.3AL250V)	SW2	SWITCH(CAPACITY CORD)	TH1	INTAKE AIR TEMP.THERMISTOR (0°C /15kΩ,25°C/5.4kΩ DETECT)
ZNR	VARISTOR	SWE	SWITCH(EMERGENCY OPERATION)	TH2	PIPE TEMP. THERMISTOR/LIQUID (0°C /15kΩ,25°C/5.4kΩ DETECT)
CN2L	CONNECTOR(LOSSNAY)	X1	RELAY(DRAIN PUMP)	TH5	COND./EVA. TEMP. THERMISTOR (0°C /15kΩ,25°C/5.4kΩ DETECT)
CN24	CONNECTOR(HEATER)	X4	RELAY(FAN MOTOR)		
CN32	CONNECTOR(REMOTE SWITCH)	X5	RELAY(FAN MOTOR)		
CN41	CONNECTOR(HA TERMINAL-A)	X6	RELAY(FAN MOTOR)		
CN51	CONNECTOR(CENTRALLY CONTROL)	P.B.	INDOOR POWER BOARD		
CN90	CONNECTOR(WIRELESS)	C	CAPACITOR(FAN MOTOR)		
LED1	POWER SUPPLY(I.B.)	MF	FAN MOTOR		
LED2	POWER SUPPLY(REMOTE CONTROLLER)	TB4	TERMINAL BLOCK (INDOOR/OUTDOOR CONNECTING LINE)		
LED3	TRANSMISSION(INDOOR•OUTDOOR)				

INSIDE SECTION OF CONTROL BOX

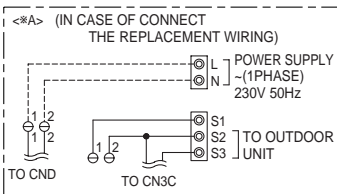
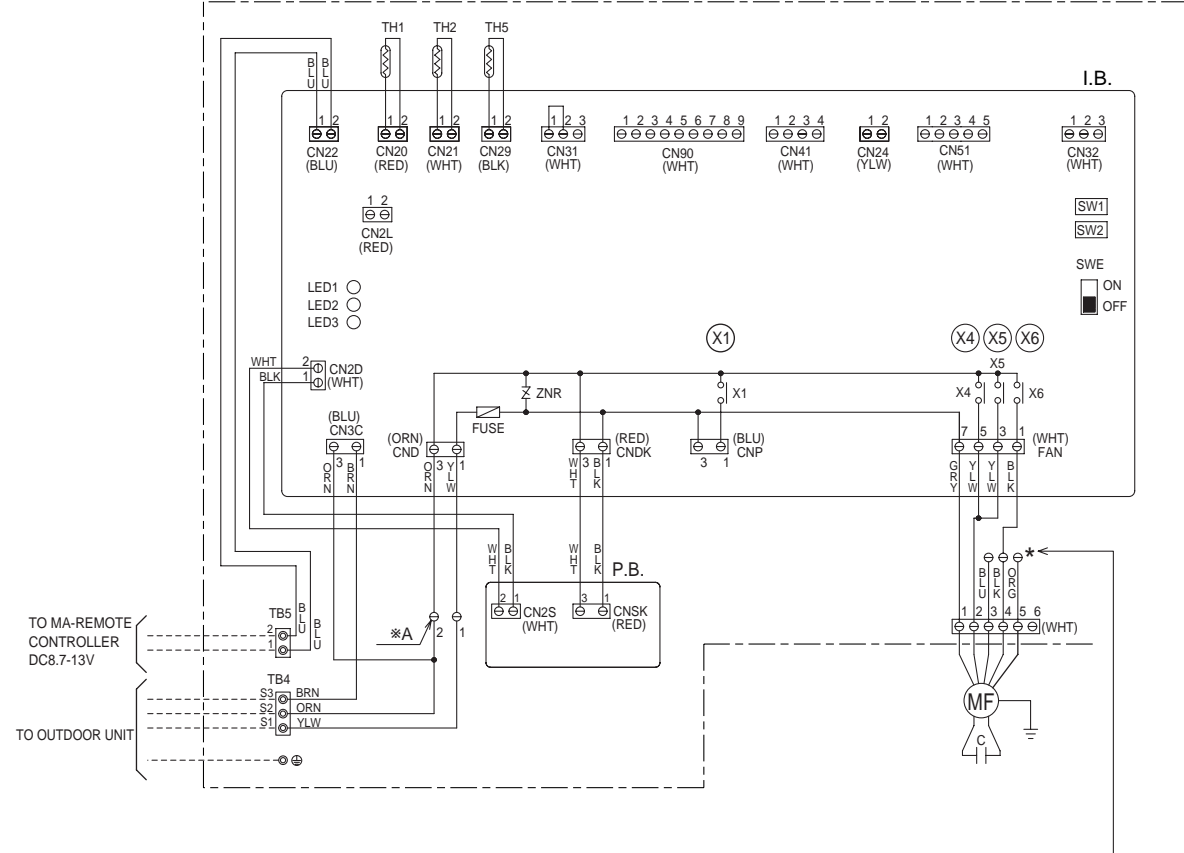

MODELS	SW1	SW2
	Model selection switch	Capacity cord switch
60GA	1 2 3 4 5 ON OFF	1 2 3 4 5 ON OFF
71GA	1 2 3 4 5 ON OFF	1 2 3 4 5 ON OFF
100GA	1 2 3 4 5 ON OFF	1 2 3 4 5 ON OFF

*External static pressure

CONNECTOR COLOR	220V	230V	240V
BLU	5Pa	10Pa	20Pa
WHT (INITIAL SETTING)	35Pa	50Pa	60Pa
RED	50Pa	70Pa	75Pa

Notes:

1. Symbols used in wiring diagram above are. : Connector, : Terminal (block).
2. Indoor and outdoor connecting wires have polarities, make sure to match terminal numbers (S1, S2, S3) for correct wirings.
3. Since the outdoor side electric wiring may change, be sure to check the outdoor unit electric wiring diagram for servicing.
4. This diagram shows the wiring of indoor and outdoor connecting wires (specification of 230V), adopting superimposed system of power and signal.
 - *1: When work to supply power separately to indoor and outdoor units was applied, refer to *A.
 - *2: For power supply system of this unit, refer to the caution label located near this diagram.

PEA-RP200, 250GA

INDOOR UNIT SYMBOL	NAME
MF1	FAN MOTOR (INDOOR)
51F	OVER CURRENT RELAY (INDOOR FAN MOTOR)
52FL0	MAGNETIC CONTACTOR (INDOOR FAN MOTOR<LOW SPEED>)
52FHi	MAGNETIC CONTACTOR (INDOOR FAN MOTOR<HIGH SPEED>)
49F	INTERNAL THERMOSTAT (INDOOR FAN MOTOR)
TB2,4,5	TERMINAL BLOCK
TH1	ROOM TEMP.
TH2	THERMISTOR
TH5	LIQUID PIPE TEMP.
X1	AUXILIARY RELAY
CR1,2	SURGE KILLER
FB	FERRITE CORE
FUSE	FUSE (T6.3AL250V)
ZNR	VARIATOR
X4-6	AUXILIARY RELAY
SW1	SWITCH (MODEL SELECTION)
SW2	SWITCH (CAPACITY CODE)
SWE	CONNECTOR (EMERGENCY OPERATION)
LED1	LED (POWER SUPPLY)
LED2	LED (POWER SUPPLY-<REMOTE CONTROLLER>)
LED3	LED (TRANSMISSION<INDOOR-OUTDOOR>)
CN2L	CONNECTOR (LOSSNAY)
CN31	CONNECTOR (DRAIN SENSOR)
CN32	CONNECTOR (REMOTE SWITCH)
CN41	CONNECTOR (HA TERMINAL-A)
CN51	CONNECTOR (CENTRALLY CONTROL)
CN90	CONNECTOR (WIRELESS REMOTE CONTROLLER)
ZNR5-7	VARIATOR
DSADR	ARRESTER
BOARD 1	

INDOOR CONTROLLER BOARD	NAME
CN2L	CONNECTOR (LOSSNAY)
CN31	CONNECTOR (DRAIN SENSOR)
CN32	CONNECTOR (REMOTE SWITCH)
CN41	CONNECTOR (HA TERMINAL-A)
CN51	CONNECTOR (CENTRALLY CONTROL)
CN90	CONNECTOR (WIRELESS REMOTE CONTROLLER)
ZNR5-7	VARIATOR
DSADR	ARRESTER

REMOTE CONTROLLER SYMBOL	NAME
TB6	TERMINAL BLOCK

- Note:1. The dotted lines show field wiring.
 2. Color of earth wire is yellow and green twisting.
 3. Specification subject to change without notice.
 4. Indoor and outdoor connecting wires have polarities, make sure to match wiring and terminal.
 5. Emergency operation
 If a trouble occurs with either the remote controller or the indoor microcomputer and no other trouble exists, emergency operation for cooling or heating can be performed by changing the setting of connector (SWE) "ON" on the indoor control board.
 SWE :ON / Indoor fan is running at high speed.
 6. ⊕ mark is connector. ⊙ mark is terminal.

- Caution,
 1. To protect fan motor from abnormal current, overcurrent relays are installed. Therefore, do not change factory set value of overcurrent relays.

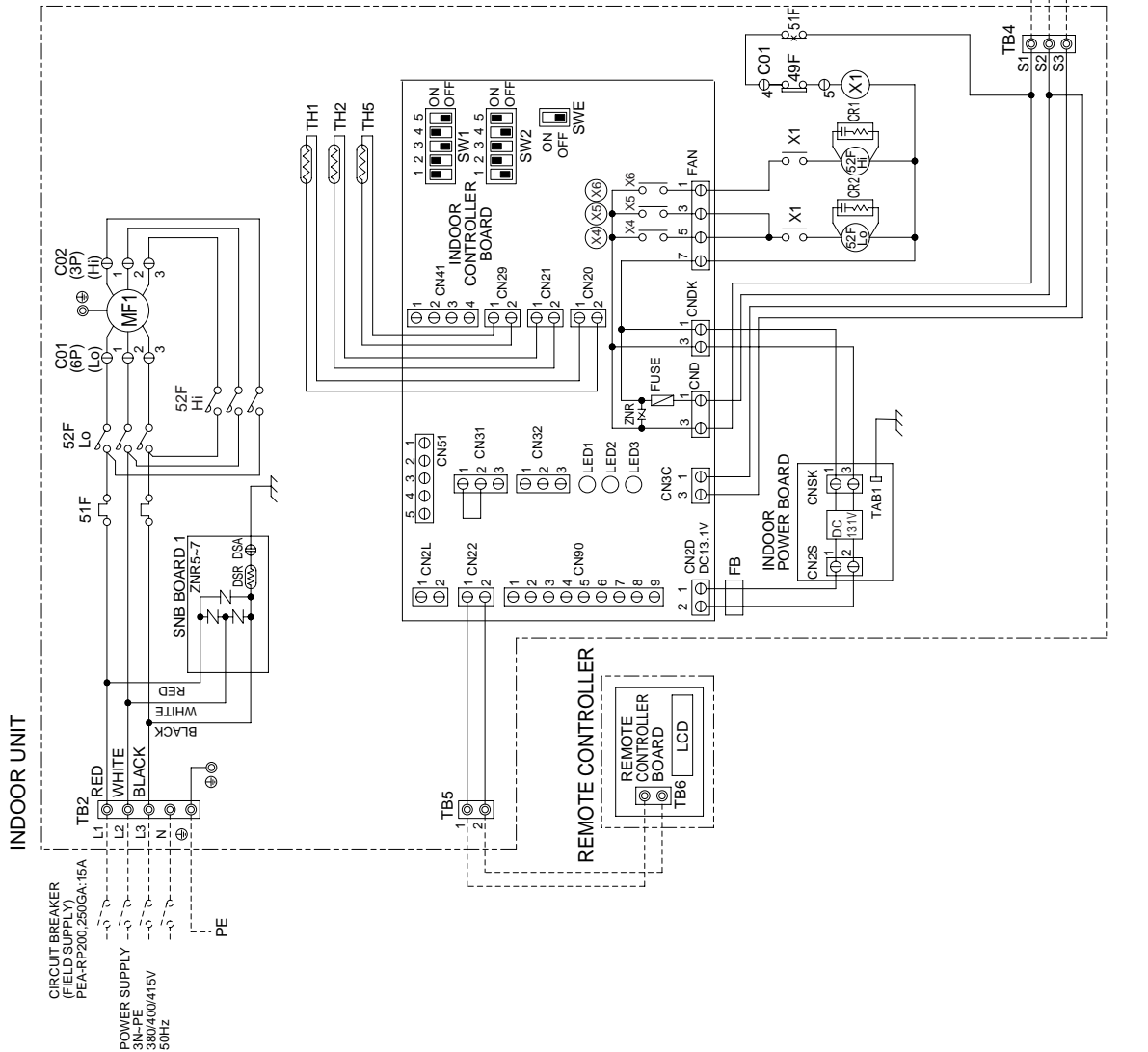

PEA-RP400, 500GA

INDOOR UNIT SYMBOL	NAME
MF1	FAN MOTOR (INDOOR)
51F	OVER CURRENT RELAY (INDOOR FAN MOTOR)
52F	MAGNETIC CONTACTOR (INDOOR FAN MOTOR)
49F	INTERNAL THERMOSTAT (INDOOR FAN MOTOR)
TB2-4-1, 4-2, 5	TERMINAL BLOCK
TH1-1, 1-2	ROOM TEMP
TH2-1, 2-2	LIQUID PIPE TEMP.
TH5-1, 5-2	COND./EVA. TEMP.
X1, 2	AUXILIARY RELAY
CR	SURGE KILLER
FB11, FB12	FERRITE CORE
FB21, FB22	FUSE (T6.3AL250V)
ZNR	VARIABLE
X4-6	AUXILIARY RELAY
SW1	SWITCH (MODEL SELECTION)
SW2	SWITCH (CAPACITY CORD)
SWE	CONNECTOR (EMERGENCY OPERATION)
LED1	LED (POWER SUPPLY)
LED2	LED (POWER SUPPLY-REMOTE CONTROLLER-)
LED3	LED (TRANSMISSION-INDOOR-OUTDOOR-)
CN2L	CONNECTOR (LOSSNAY)
CN31	CONNECTOR (DRAIN SENSOR)
CN32	CONNECTOR (REMOTE SWITCH)
CN41	CONNECTOR (HA TERMINAL-A)
CN51	CONNECTOR (CENTRALLY CONTROL)
CN90	CONNECTOR (WIRELESS REMOTE CONTROLLER)
ZNR5-7	VARIABLE
DSA, DSR	ARRESTER
BOARD 1	

OUTDOOR UNIT SYMBOL	NAME
TB3, TB8	TERMINAL BLOCK
REMOTE CONTROLLER SYMBOL	NAME
TB6	TERMINAL BLOCK

- Note:1. The dotted lines show field wiring.
 2. Color of earth wire is yellow and green twisting.
 3. Specification subject to change without notice.
 4. Indoor and outdoor connecting wires have polarities, make sure to match wiring and terminal.
 5. Emergency operation
 If a trouble occurs with either the remote controller or the indoor microcomputer and no other trouble exists, emergency operation for cooling or heating can be performed by changing the setting of connector (SWE) "ON" on the indoor controller board.
 SWE :ON / Indoor fan is running at high speed.
 6. Ⓞmark is connector, ⊗mark is terminal.

Caution,
 1. To protect fan motor from abnormal current, overcurrent relays are installed.
 Therefore, do not change factory set value of overcurrent relays.

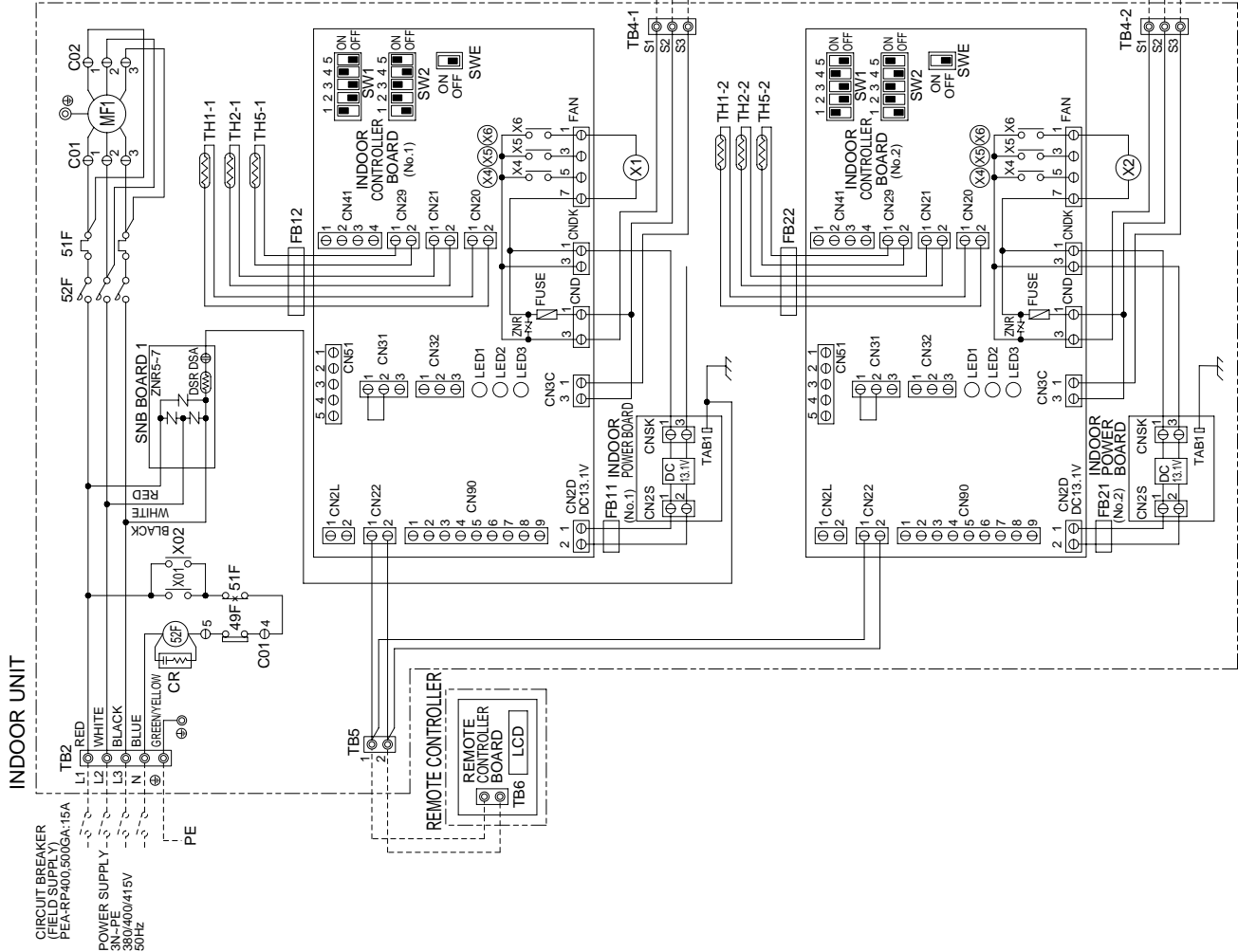

PKA-RP50GAL

[LEGEND]

SYMBOL	NAME	SYMBOL	NAME	SYMBOL	NAME
P.B	INDOOR POWER BOARD	C	CAPACITOR <FAN MOTOR>	W.B	WIRELESS REMOTE CONTROLLER BOARD
I.B	INDOOR CONTROLLER BOARD	MF	FAN MOTOR	RU	RECEIVING UNIT
FUSE	FUSE (T6.3AL250V)	MV	VANE MOTOR	BZ	BUZZER
ZNR	VARIATOR	TB2	TERMINAL BLOCK (HEATER) *PKH-P.GALH models only or option for PKA-RP.GAL models.	LED1	LED <RUN INDICATOR>
CN2L	CONNECTOR <LOSSNAY>	TB4	TERMINAL BLOCK <INDOOR/ OUTDOOR CONNECTING LINE>	LED2	LED <HOT ADJUST>
CN32	CONNECTOR <REMOTE SWITCH>	TB5, TB6	TERMINAL BLOCK <REMOTE CONTROLLER TRANSMISSION LINE> <OPTION>	SW1	SWITCH (HEATING ON/ OFF)
CN41	CONNECTOR <HA TERMINAL-A>	TH1	ROOM TEMP.THERMISTOR <0°C/ 15kΩ, 25°C/ 5.4kΩ DETECT>	SW2	SWITCH (COOLING ON/ OFF)
CN51	CONNECTOR <CENTRALLY CONTROL>	TH2	PIPE TEMP.THERMISTOR/ LIQUID <0°C/ 15kΩ, 25°C/ 5.4kΩ DETECT>	R.B	WIRED REMOTE CONTROLLER BOARD
SW1	SWITCH <MODEL SELECTION>*See Table 1.	TH5	COND./ EVA.TEMP.THERMISTOR <0°C/ 15kΩ, 25°C/ 5.4kΩ DETECT>	HEATER	
SW2	SWITCH <CAPACITY CODE>*See Table 2.			FS1	THERMAL FUSE <104°C 10A>
SWE	SWITCH <EMERGENCY OPERATION>			FS2	THERMAL FUSE <84°C 10A>
X4	RELAY <FAN MOTOR>			H1	HEATER
BCR	FAN CONTROL ELEMENT			26H	HEATER THERMAL SWITCH
LED1	POWER SUPPLY <I.B>			88H	HEATER CONTACTOR
LED2	POWER SUPPLY <R.B>				
LED3	TRANSMISSION <INDOOR-OUTDOOR>				

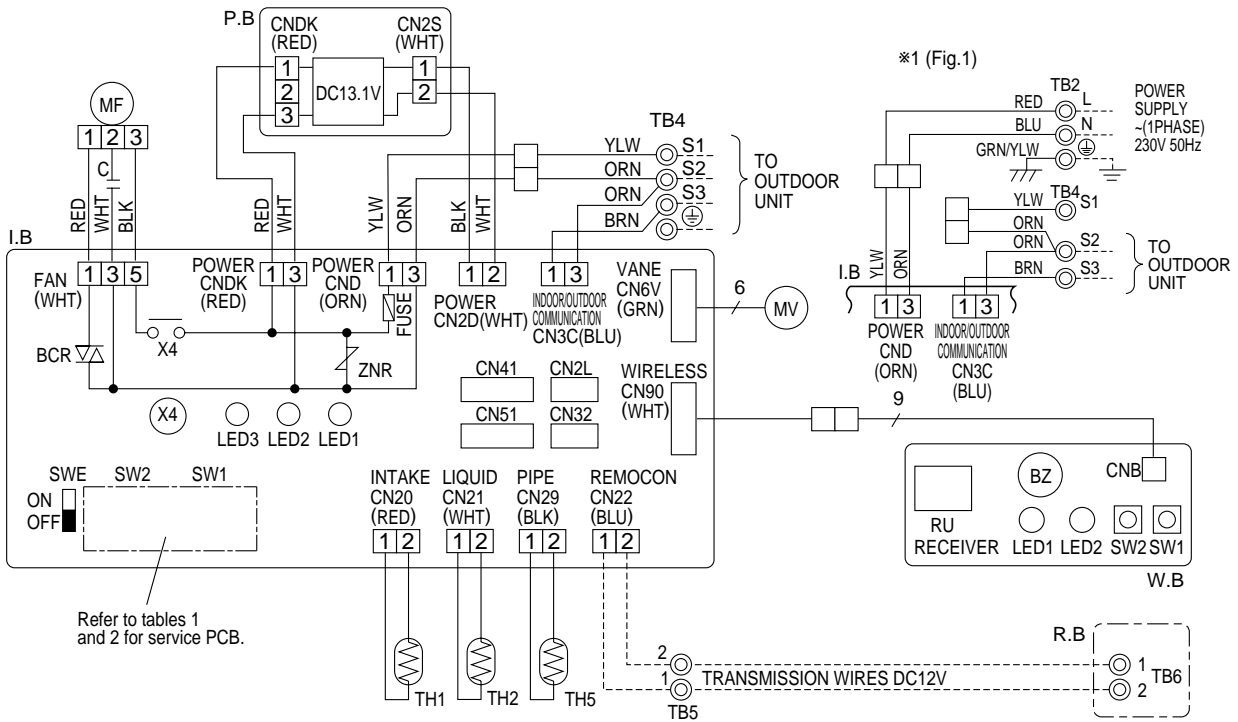

Refer to tables 1 and 2 for service PCB.

PKH-P50GALH models only

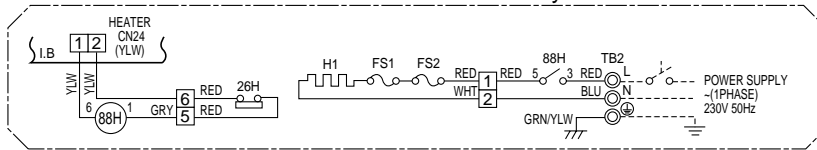

Please set the voltage using the remote controller. For the setting method, please refer to the indoor unit Installation Manual.

SW1				
1	2	3	4	5
ON	OFF	ON	OFF	ON

SW2				
1	2	3	4	5
ON	OFF	ON	OFF	ON

Notes:

1. Symbols used in wiring diagram above are, □: Connector, ⊙: Terminal (block).
2. Indoor and outdoor connecting wires have polarities, make sure to match terminal numbers (S1, S2, S3) for correct wirings.
3. Since the outdoor side electric wiring may change, be sure to check the outdoor unit electric wiring diagram for servicing.
4. This diagram shows the wiring of indoor and outdoor connecting wires (specification of 230V), adopting superimposed system of power and signal.
 - *1: When work to supply power separately to indoor and outdoor units was applied, refer to Fig 1.
 - *2: For power supply system of this unit, refer to the caution label located near this diagram.

PKA-RP50FAL2 PKA-RP60FAL PKA-RP71FAL PKA-RP100FAL

[LEGEND]

SYMBOL	NAME	SYMBOL	NAME	SYMBOL	NAME
P.B	INDOOR POWER BOARD	C	CAPACITOR(FAN MOTOR)	W.B	WIRELESS REMOTE CONTROLLER BOARD
I.B	INDOOR CONTROLLER BOARD	MF	FAN MOTOR	RU	RECEIVING UNIT
FUSE	FUSE(T6.3AL250V)	MV	VANE MOTOR	BZ	BUZZER
ZNR	VARISTOR	TB2	TERMINAL BLOCK(HEATER) *PKH-P.FALH models only or option for PKA-RP.FALH models.	LED1	LED(RUN INDICATOR)
CN2L	CONNECTOR(LOSSNAY)	TB4	TERMINAL BLOCK(INDOOR/OUTDOOR CONNECTING LINE)	LED2	LED(HOT ADJUST)
CN32	CONNECTOR(REMOTE SWITCH)	TB5	TERMINAL BLOCK(REMOTE CONTROLLER TRANSMISSION LINE)(OPTION)	SW1	SWITCH(HEATING ON/OFF)
CN41	CONNECTOR(HA TERMINAL-A)	TH1	ROOM TEMP.THERMISTOR (0°C/15kΩ, 25°C/5.4kΩ DETECT)	SW2	SWITCH(COOLING ON/OFF)
CN51	CONNECTOR(CENTRALLY CONTROL)	TH2	PIPE TEMP.THERMISTOR/LIQUID (0°C/15kΩ, 25°C/5.4kΩ DETECT)	R.B	WIREDREMOTE CONTROLLER BOARD(OPTION)
SW1	SWITCH(MODEL SELECTION) * See Table 1.	TH5	COND./EVA.TEMP.THERMISTOR (0°C/15kΩ, 25°C/5.4kΩ DETECT)	TB6	TERMINAL BLOCK(REMOTE CONTROLLER TRANSMISSION LINE)
SW2	SWITCH(CAPACITY CODE) * See Table 2.			HEATER	
SWE	SWITCH(EMERGENCY OPERATION)			FS1,2	THERMAL FUSE(117°C 10A:60.71FALH/ 117°C 16A:100FALH)
X4	RELAY(FAN MOTOR)			H1	HEATER
BCR	FAN CONTROL ELEMENT			26H	HEATER THERMAL SWITCH
LED1	POWER SUPPLY(L.B)			88H	HEATER CONTACTOR
LED2	POWER SUPPLY(R.B)				
LED3	TRANSMISSION(INDOOR-OUTDOOR)				

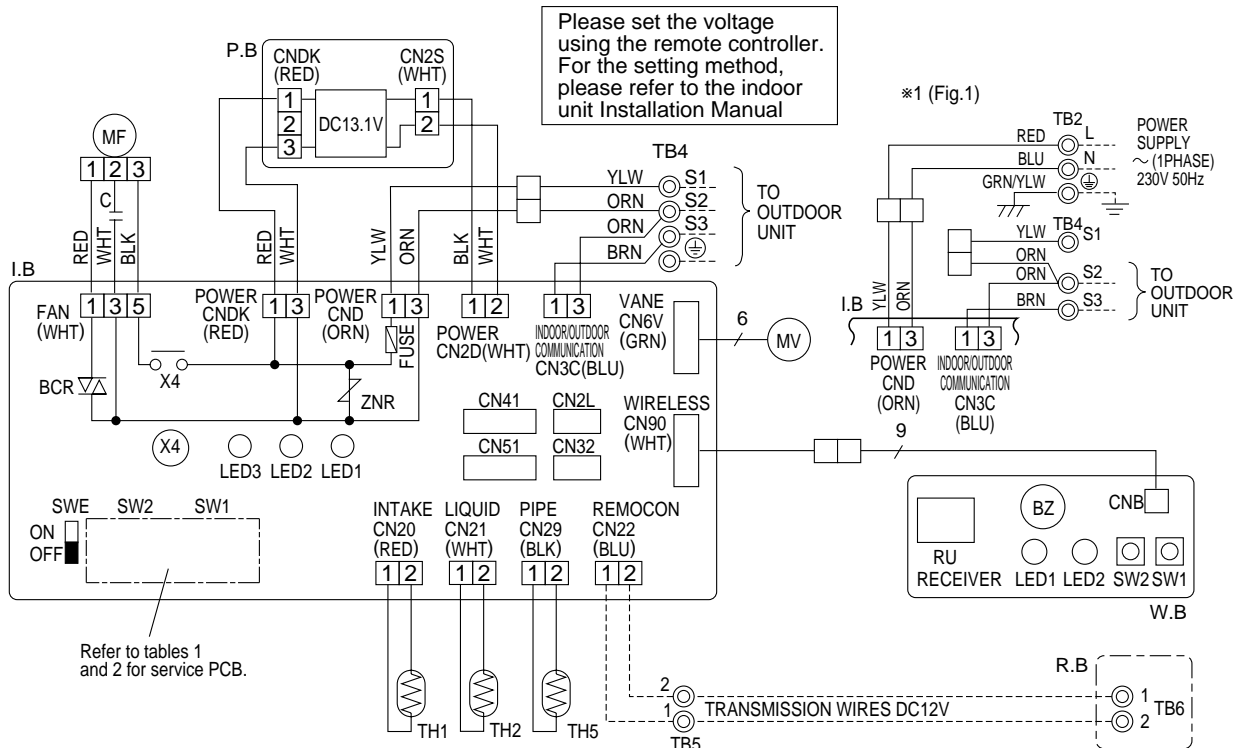

Table 1

SW1	Service board
1 2 3 4 5	ON OFF

Table 2

MODELS		Service board	MODELS		Service board	MODELS		Service board
PKA-RP50FAL2	PKA-RP60FAL	1 2 3 4 5	PKA-RP71FAL	PKH-P71FALH	1 2 3 4 5	PKA-RP100FAL	PKH-P100FALH	1 2 3 4 5
	PKH-P60FALH	ON OFF			ON OFF			ON OFF

PKH-P60~P100FALH models only

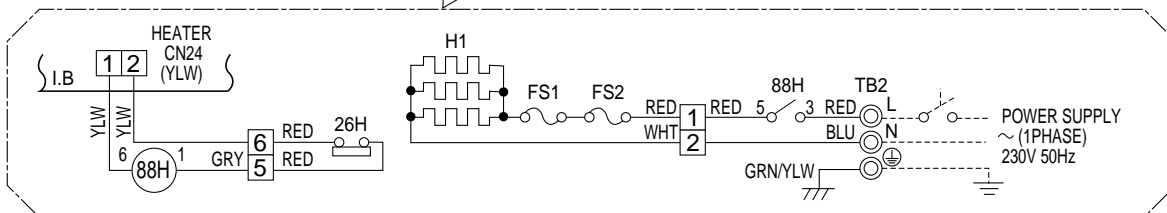

Notes:

- Symbols used in wiring diagram above are, □: Connector, ⊙: Terminal (block).
 - Indoor and outdoor connecting wires have polarities, make sure to match terminal numbers (S1, S2, S3) for correct wirings.
 - Since the outdoor side electric wiring may change, be sure to check the outdoor unit electric wiring diagram for servicing.
 - This diagram shows the wiring of indoor and outdoor connecting wires (specification of 230V), adopting superimposed system of power and signal.
- *1: When work to supply power separately to indoor and outdoor units was applied, refer to Fig 1.
 *2: For power supply system of this unit, refer to the caution label located near this diagram.

PCA-RP50GA PCA-RP50GA2 PCA-RP60GA
 PCA-RP100GA PCA-RP125GA PCA-RP140GA

PCA-RP71GA

[LEGEND]

SYMBOL	NAME	SYMBOL	NAME	SYMBOL	NAME
P.B	INDOOR POWER BOARD	MF	FAN MOTOR	W.B	WIRELESS REMOTE CONTROLLER BOARD(OPTION)
I.B	INDOOR CONTROLLER BOARD	MV	VANE MOTOR	RU	RECEIVING UNIT
FUSE	FUSE (T6.3AL250V)	DP	DRAIN-UP MACHINE (OPTION)	BZ	BUZZER
ZNR	VARISTOR	DS	DRAIN SENSOR (OPTION)	LED1	LED(RUN INDICATOR)
CN2L	CONNECTOR(LOSSNAY)	TB2	TERMINAL BLOCK (HEATER) *PCH-P.GAH models only or option for PCA RP.GA models.	LED2	LED(HOT ADJUST)
CN32	CONNECTOR(REMOTE SWITCH)	TB4	TERMINAL BLOCK(INDOOR/OUTDOOR CONNECTING LINE)	SW1	SWITCH(HEATING ON/OFF)
CN41	CONNECTOR(HA TERMINAL-A)	TB5,TB6	TERMINAL BLOCK(REMOTE CONTROLLER TRANSMISSION LINE)	SW2	SWITCH(COOLING ON/OFF)
CN51	CONNECTOR(CENTRALLY CONTROL)	TH1	ROOM TEMP.THERMISTOR (0°C/15kΩ, 25°C/5.4kΩ DETECT)	HEATER	
SW1	SWITCH (MODEL SELECTION) *See Table 1.	TH2	PIPE TEMP.THERMISTOR/LIQUID (0°C/15kΩ, 25°C/5.4kΩ DETECT)	FS1,2	THERMAL FUSE(98°C/10A:50GAH/117°C/16A:100GAH 110°C/16A:60,71,125,140GAH)
SW2	SWITCH (CAPACITY CODE) *See Table 2.	TH5	COND./EVA.TEMP.THERMISTOR (0°C/15kΩ, 25°C/5.4kΩ DETECT)	H1	HEATER
SWE	SWITCH(EMERGENCY OPERATION)	R.B	WIRED REMOTE CONTROLLER BOARD	26H	HEATER THERMAL SWITCH
X1	RELAY(DRAIN PUMP)			88H	HEATER CONTACTOR
X4	RELAY(FAN MOTOR)				
BCR	FAN CONTROL ELEMENT				
LED1	POWER SUPPLY(L.B)				
LED2	POWER SUPPLY(R.B)				
LED3	TRANSMISSION(INDOOR-OUTDOOR)				
C	CAPACITOR(FAN MOTOR)				

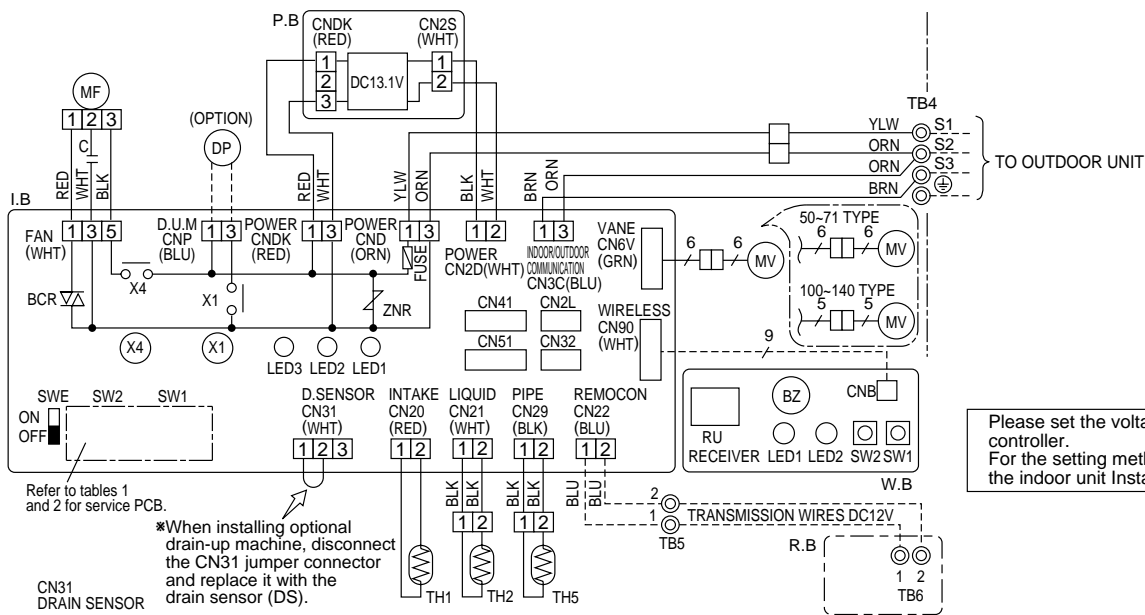

Please set the voltage using the remote controller. For the setting method, please refer to the indoor unit Installation Manual.

[Servicing]
 Fasten terminal of the terminal board "TB4" that equips lock system. To remove the fastened terminal, pull it while pressing the protruding portion (locking lever) of the terminal. The fastened terminal protruding portion should face upward.

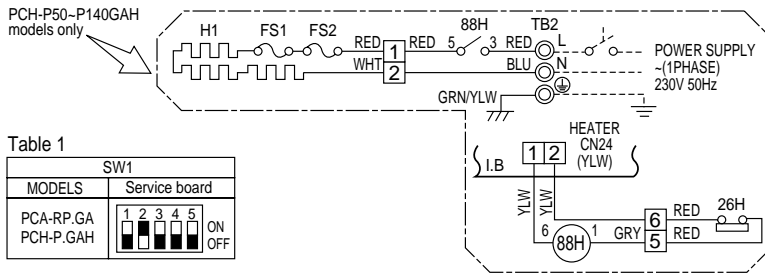

Table 1

MODELS	SW1				
	Service board				
PCA-RP.GA PCH-P.GAH	1	2	3	4	5
	ON	OFF	ON	OFF	ON

Table 2

MODELS	SW2				
	Service board				
PCA-RP50GA PCH-P50GAH	1	2	3	4	5
	ON	OFF	ON	OFF	ON
PCA-RP50GA2 PCA-RP60GA PCH-P60GAH	1	2	3	4	5
	ON	OFF	ON	OFF	ON
PCA-RP71GA PCH-P71GAH	1	2	3	4	5
	ON	OFF	ON	OFF	ON
PCA-RP100GA PCH-P100GAH	1	2	3	4	5
	ON	OFF	ON	OFF	ON
PCA-RP125GA PCH-P125GAH	1	2	3	4	5
	ON	OFF	ON	OFF	ON
PCA-RP140GA PCH-P140GAH	1	2	3	4	5
	ON	OFF	ON	OFF	ON

Notes:

- Symbols used in wiring diagram above are, □ : Connector, ⊙ : Terminal (block).
- Indoor and outdoor connecting wires have polarities, make sure to match terminal numbers (S1, S2, S3) for correct wirings.
- Since the outdoor side electric wiring may change, be sure to check the outdoor unit electric wiring diagram for servicing.
- This diagram shows the wiring of indoor and outdoor connecting wires (specification of 230V), adopting superimposed system of power and signal.
 *1: When work to supply power separately to indoor and outdoor units was applied, refer to Fig 1.
 *2: For power supply system of this unit, refer to the caution label located near this diagram.

PCA-RP71HA PCA-RP125HA

[LEGEND]

SYMBOL	NAME	SYMBOL	NAME
P. B	INDOOR POWER BOARD	MF1, MF2	FAN MOTOR
I. B	INDOOR CONTROLLER BOARD	C1, C2	CAPACITOR(FAN MOTOR)
	FUSE	H2	DEW PREVENTION HEATER
	ZNR	TB2	TERMINAL BLOCK(INDOOR UNIT POWER (OPTION))
	CN2L		CONNECTOR (LOSSNAY)
	CN32	TB4	TERMINAL BLOCK(INDOOR/OUTDOOR CONNECTING LINE)
	CN41		CONNECTOR (HA TERMINAL-A)
	CN51	TB5, TB6	TERMINAL BLOCK(REMOTE CONTROLLER TRANSMISSION LINE)
	LED1		POWER SUPPLY (I. B)
	LED2		POWER SUPPLY (R. B)
	LED3	TH1	ROOM TEMP.THERMISTOR (0°C/15kΩ, 25°C/5.4kΩ DETECT)
	X1	TH2	PIPE TEMP.THERMISTOR/LIQUID (0°C/15kΩ, 25°C/5.4kΩ DETECT)
	X4		RELAY(FAN MOTOR)
	X5		RELAY(FAN MOTOR)
	X6	TH5	COND./ EVA.TEMP.THERMISTOR (0°C/15kΩ, 25°C/5.4kΩ DETECT)
	SW1	R. B	WIRED REMOTE CONTROLLER BOARD
	SW2		SWITCH (CAPACITY CODE)※See Table 2.
	SWE		SWITCH (EMERGENCY OPERATION)

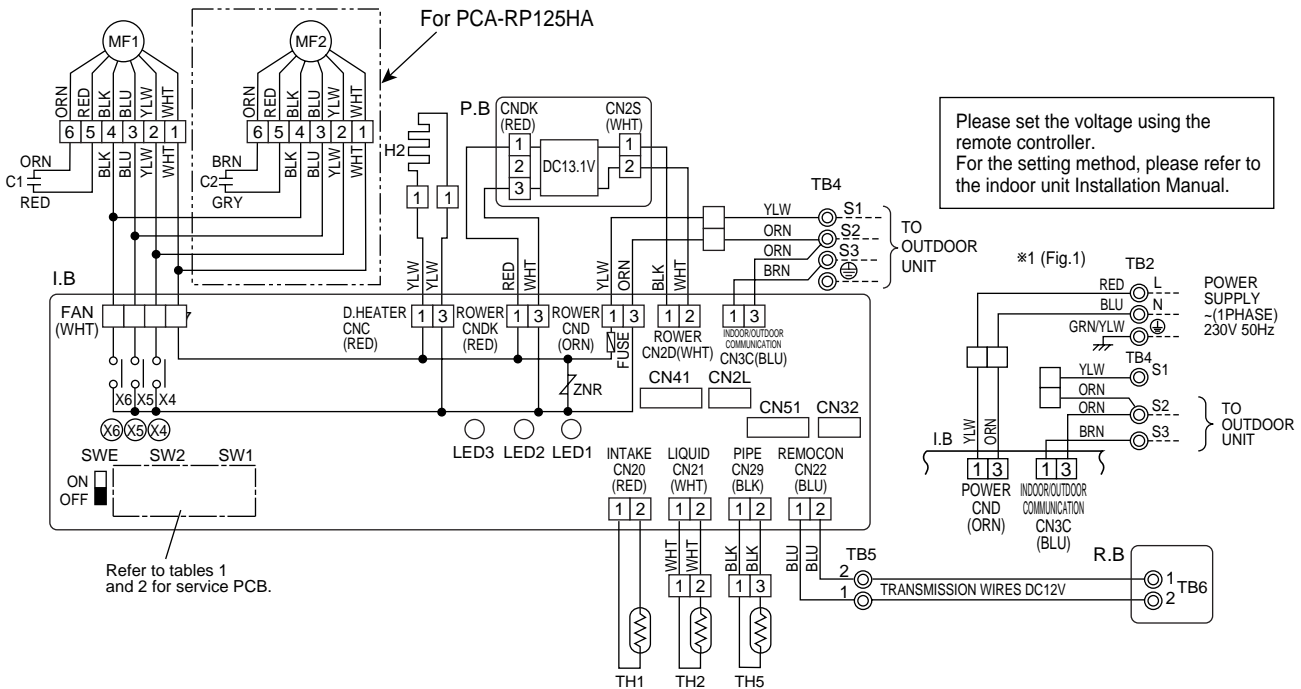

Table 1

SW1				
Service board				
1	2	3	4	5
ON	OFF	ON	OFF	ON

Table 2

SW2							
MODELS		Service board		MODELS		Service board	
PCA-RP71HA	1	2	3	4	5	PCA-RP125HA	1
	ON	OFF	ON	OFF	ON	OFF	ON

Notes:

- Symbols used in wiring diagram above are, : Connector, : Terminal (block).
- Indoor and outdoor connecting wires have polarities, make sure to match terminal numbers (S1, S2, S3) for correct wirings.
- Since the outdoor side electric wiring may change, be sure to check the outdoor unit electric wiring diagram for servicing.
- This diagram shows the wiring of indoor and outdoor connecting wires (specification of 230V), adopting superimposed system of power and signal.
 - *1: When work to supply power separately to indoor and outdoor units was applied, refer to Fig 1.
 - *2: For power supply system of this unit, refer to the caution label located near this diagram.

PSA-RP71GA PSA-RP100GA PSA-RP125GA PSA-RP140GA

[LEGEND]

SYMBOL	NAME	SYMBOL	NAME	SYMBOL	NAME
P.B	INDOOR POWER BOARD	I.B	INDOOR CONTROLLER BOARD	C	CAPACITOR (FAN MOTOR)
I.B	FUSE (T6.3AL250V)	SW1	SWITCH (MODEL SELECTION) ※See Table 1.	MF	FAN MOTOR
ZNR	VARISTOR	SW2	SWITCH (CAPACITY CODE) ※See Table 2.	ML	LOUVER MOTOR
CN2L	CONNECTOR (LOSSNAY)	SWE	SWITCH (EMERGENCY OPERATION)	TB2	TERMINAL BLOCK (HEATER) ※PSH-P.GAH models only or option for PSA-RP.GA models.
CN32	CONNECTOR (REMOTE SWITCH)	X2	RELAY (LOUVER)	TB4	TERMINAL BLOCK (INDOOR/OUTDOOR CONNECTING LINE)
CN41	CONNECTOR (HA TERMINAL-A)	X4	RELAY (FAN MOTOR)	TH1	ROOM TEMP.THERMISTOR (0°C/15kΩ, 25°C/5.4kΩ DETECT)
CN51	CONNECTOR (CENTRALLY CONTROL)	X5	RELAY (FAN MOTOR)	TH2	PIPE TEMP.THERMISTOR/LIQUID (0°C/15kΩ, 25°C/5.4kΩ DETECT)
LED1	POWER SUPPLY (I.B)	X6	RELAY (FAN MOTOR)	TH5	COND./EVA.TEMP.THERMISTOR (0°C/15kΩ, 25°C/5.4kΩ DETECT)
LED2	POWER SUPPLY (R.B)	R.B	WIRED REMOTE CONTROLLER BOARD		
LED3	TRANSMISSION (INDOOR-OUTDOOR)	TB6	TERMINAL BLOCK (REMOTE CONTROLLER TRANSMISSION LINE)		
		HEATER			
		FS1,2	THERMAL FUSE (110°C/16A)		
		H	HEATER		
		26H	HEATER THERMAL SWITCH		
		88H	HEATER CONTACTOR		

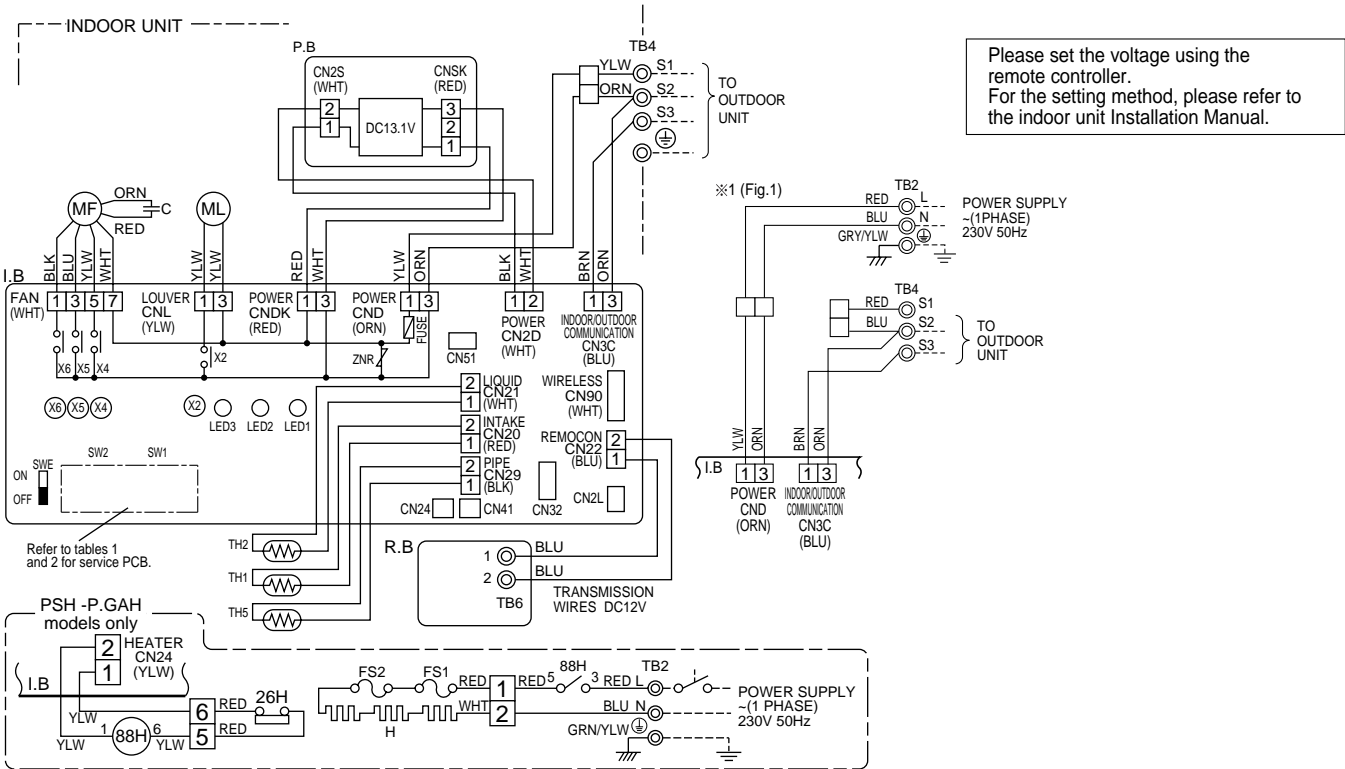

Table 1

MODELS	Service board
PSA-RP.GA	1 2 3 4 5 ON
PSH-P.GAH	1 2 3 4 5 OFF

Notes:

1. Symbols used in wiring diagram above are, : Connector, : Terminal (block).
2. Indoor and outdoor connecting wires have polarities, make sure to match terminal numbers (S1, S2, S3) for correct wirings.
3. Since the outdoor side electric wiring may change, be sure to check the outdoor unit electric wiring diagram for servicing.
4. This diagram shows the wiring of indoor and outdoor connecting wires (specification of 230V), adopting superimposed system of power and signal.
 ※1: When work to supply power separately to indoor and outdoor units was applied, refer to Fig 1.
 ※2: For power supply system of this unit, refer to the caution label located near this diagram.

Table 2

MODELS	Service board
PSA-RP71GA	1 2 3 4 5 ON
PSH-P71GAH	1 2 3 4 5 OFF
PSA-RP100GA	1 2 3 4 5 ON
PSH-P100GAH	1 2 3 4 5 OFF
PSA-RP125GA	1 2 3 4 5 ON
PSH-P125GAH	1 2 3 4 5 OFF
PSA-RP140GA	1 2 3 4 5 ON
PSH-P140GAH	1 2 3 4 5 OFF

PUHZ-P100VHA2 PUHZ-P125VHA2 PUHZ-P140VHA2

[LEGEND]

SYMBOL	NAME	SYMBOL	NAME	SYMBOL	NAME
TB1	Terminal Block<Power Supply, Indoor/Outdoor >	P.B.	Power Circuit Board	SW8	Switch
MC	Motor Compressor	TABU/W/W	Connection Terminal<U/V/W-Phase>	SW9	Switch
MF1,MF2	Fan Motors	TABS/T	Connection Terminal<L/N- Phase>	SWP	Switch<Pump Down>
21S4	Solenoid Valve (Four-Way Valve)	TABP1/P2/P	Connection Terminal<DC Voltage>	CN31	Connector<Emergency Operation>
SV	Solenoid Valve (Bypass Valve)	TABN1/N2/N	Connection Terminal<DC Voltage>	LED1,LED2	Light Emitting Diodes <Operation Inspection Indicators>
CH	Crankcase Heater	DS2,3	Diode Bridge	CNM	Connector<A-Control Service Inspection Kit>
63H	High Pressure Switch	IPM	Power Module	CNMNT	Connector<Connected to Optional M-NET Adapter Board>
TH3	Thermistor<Outdoor Pipe>	N.F.	Noise Filter Circuit Board	CNMNT	Connector<Connected to Optional M-NET Adapter Board>
TH4	Thermistor<Discharge>	C.B.	Controller Circuit Board	CNVMT	Connector<Connected to Optional M-NET Adapter Board>
TH6	Thermistor<Outdoor 2-Phase Pipe>	F1-F4	Fuse<T6.3AL250V>	CNDM	Connector< Connected for Option (Contact Input)>
TH7	Thermistor<Outdoor>	SW1	Switch<Forced Defrost, Defect History Record Reset, Refrigerant Address>	X51,X52,X54,X55	Relay
TH8	Thermistor<Heatsink>	SW4	Switch<Test Operation>		
LEV-A	Electronic Expansion Valve	SW5	Switch<Function Switch>		
DCL	Reactor	SW6	Switch<Model Select>		
ACTM	Active Filter Module	SW7	Switch<Function Setup>		
CB	Main Smoothing Capacitor				

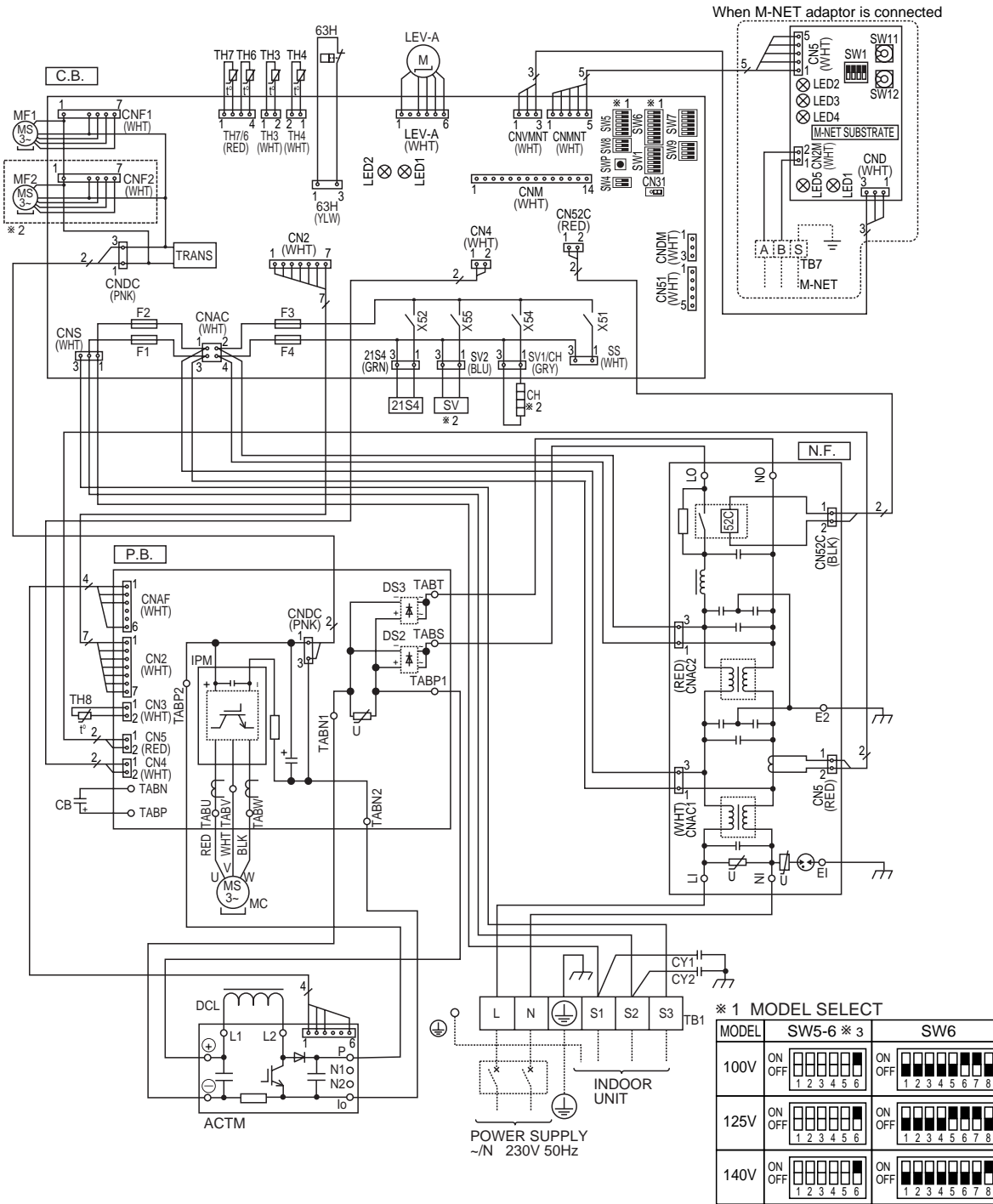

When M-NET adaptor is connected

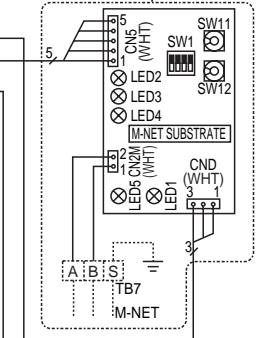

※ 1 MODEL SELECT

MODEL	SW5-6 ※ 3	SW6
100V	ON OFF [1 2 3 4 5 6]	ON OFF [1 2 3 4 5 6 7 8]
125V	ON OFF [1 2 3 4 5 6]	ON OFF [1 2 3 4 5 6 7 8]
140V	ON OFF [1 2 3 4 5 6]	ON OFF [1 2 3 4 5 6 7 8]

※ 2 P125,P140 only
 ※ 3 SW5-1 to 5 : Function Switch

PUHZ-P200YHA PUHZ-P250YHA

[LEGEND]

SYMBOL	NAME	SYMBOL	NAME	SYMBOL	NAME
TB1	Terminal Block<Power Supply>	TB-L1/L2/L3	Connection Terminal<L1/L2/L3-Power supply>	SWP	Switch<Pump Down>
TB2	Terminal Block<Indoor/Outdoor>	TB-P1	Connection Terminal	CN31	Connector<Emergency Operation>
MC	Motor for Compressor	TB-P2	Connection Terminal	LED1, LED2	LED<Operation Inspection Indicators>
MF1, MF2	Fan Motor	TB-C1	Connection Terminal	F3, F4	Fuse< T6.3AL250V>
Z1S4	Solenoid Valve (Four-Way Valve)	TB-N1	Connection Terminal	SS	Connector<Connection for Option>
63H	High Pressure Switch	X52A	52C Relay	CNM	Connector<A-Control Service Inspection Kit>
TH3	Thermistor<Outdoor Pipe>	N.F.	Noise Filter Circuit Board	CNMNT	Connector <Connected to Optional M-NET Adapter Board>
TH4	Thermistor<Discharge>	L1/L2/L3/NI	Connection Terminal<L1/L2/L3/NI-Power supply>	CNMVMT	Connector <Connected to Optional M-NET Adapter Board>
TH6	Thermistor<Outdoor 2-Phase Pipe>	L01/L02/L03	Connection Terminal<L1/L2/L3-Power supply>	CNDM	Connector < Connected for Option (Contact Input)>
TH7	Thermistor<Outdoor>	GD1, GD2	Connection Terminal<Ground>	CN3S	Connector<Connection for Option>
LEV-A	Electronic Expansion Valve	C.B.	Controller Circuit Board	CN51	Connector<Connection for Option>
ACL4	Reactor	SW1	Switch<Forced Defrost, Defect History Record Reset, Refrigerant Address>	X51, X52	Relay
DCL	Reactor	SW4	Switch<Test Operation>		
CB1, CB2	Main Smoothing Capacitor	SW5	Switch<Function Switch>		
RS	Rush Current Protect Resistor	SW6	Switch<Model Select>		
FUSE1, FUSE2	Fuse<T15AL250V>	SW7	Switch<Function Setup>		
CY1, CY2	Capacitor	SW8	Switch<Function Setup>		
P.B.	Power Circuit Board	SW9	Switch		
SC-U/V/W	Connection Terminal<U/V/W-Phase>				

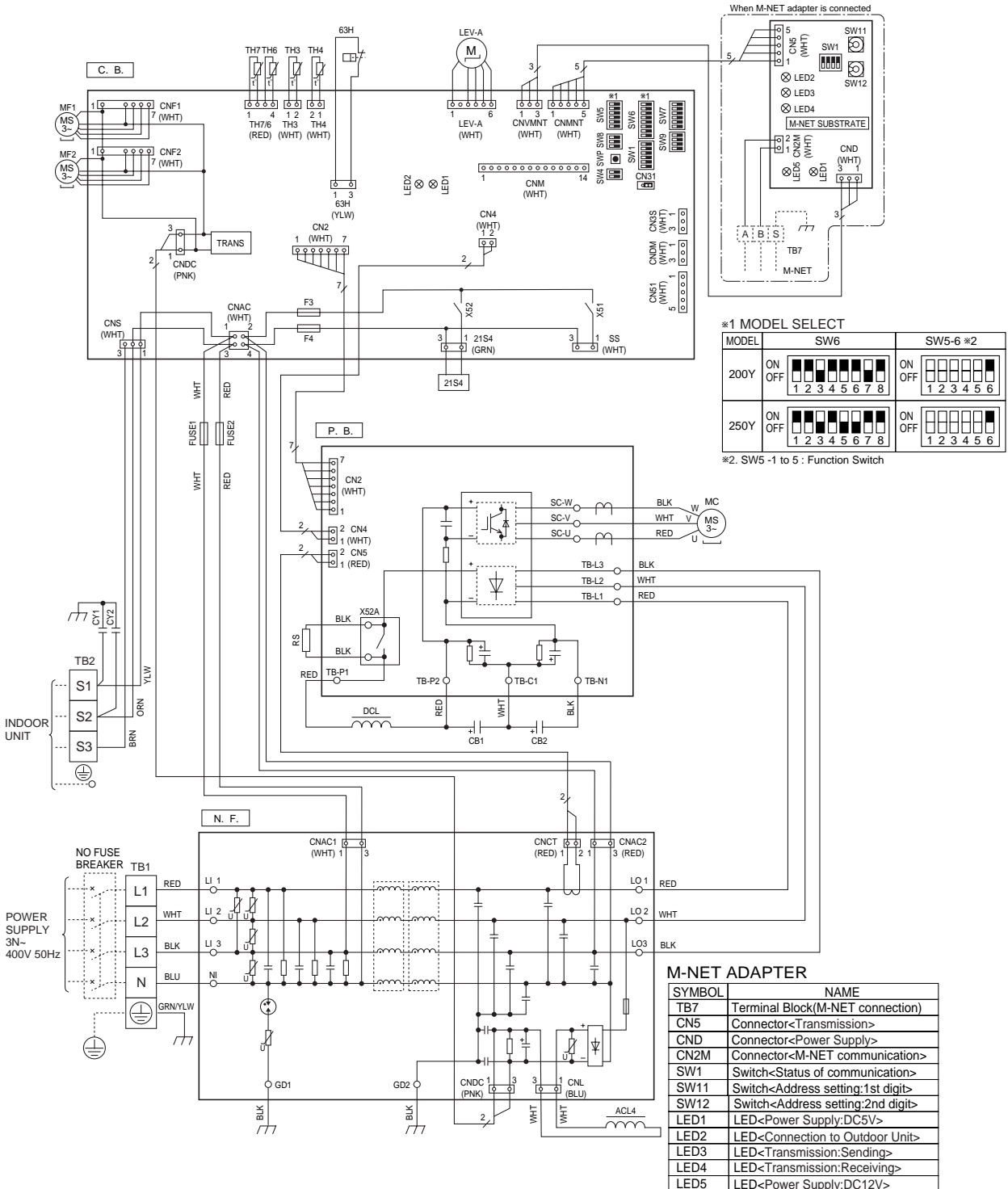

5-1. INDOOR UNIT

- | | | |
|---------------|---------------|-----------|
| PLA-RP-BA | PCA-RP-GA(2) | PCA-RP-HA |
| PKA-RP-GAL | PKA-RP-FAL(2) | PSA-RP-GA |
| PEAD-RP-EA(2) | PEAD-RP-GA | |

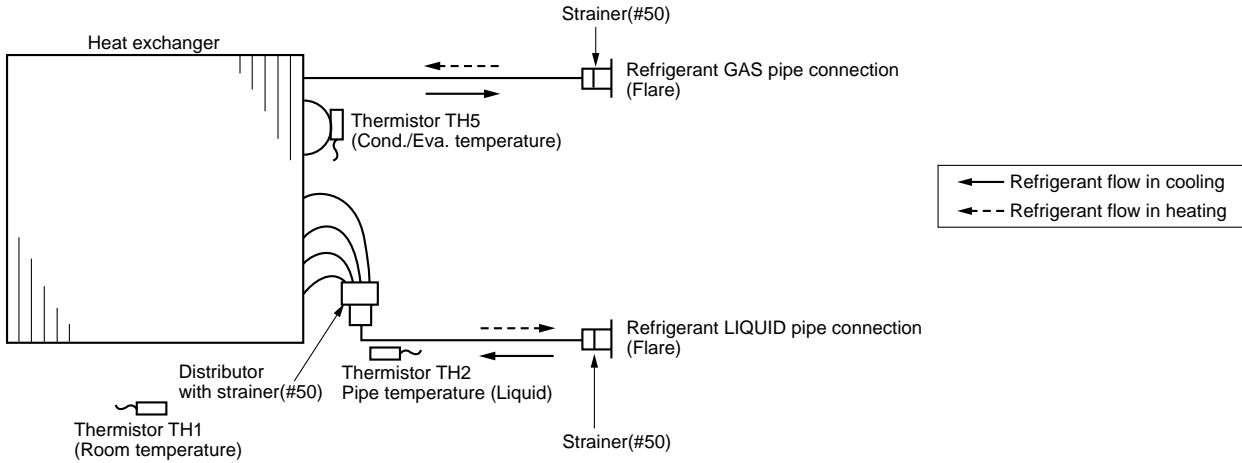

PEA-RP200, 250GA

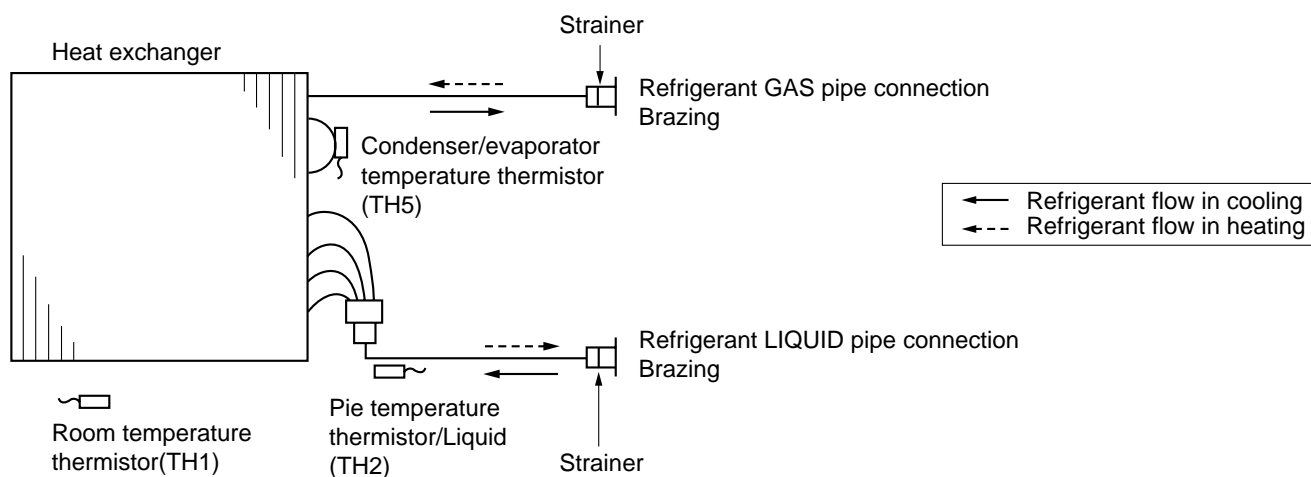

PEA-RP400GA PEA-RP500GA

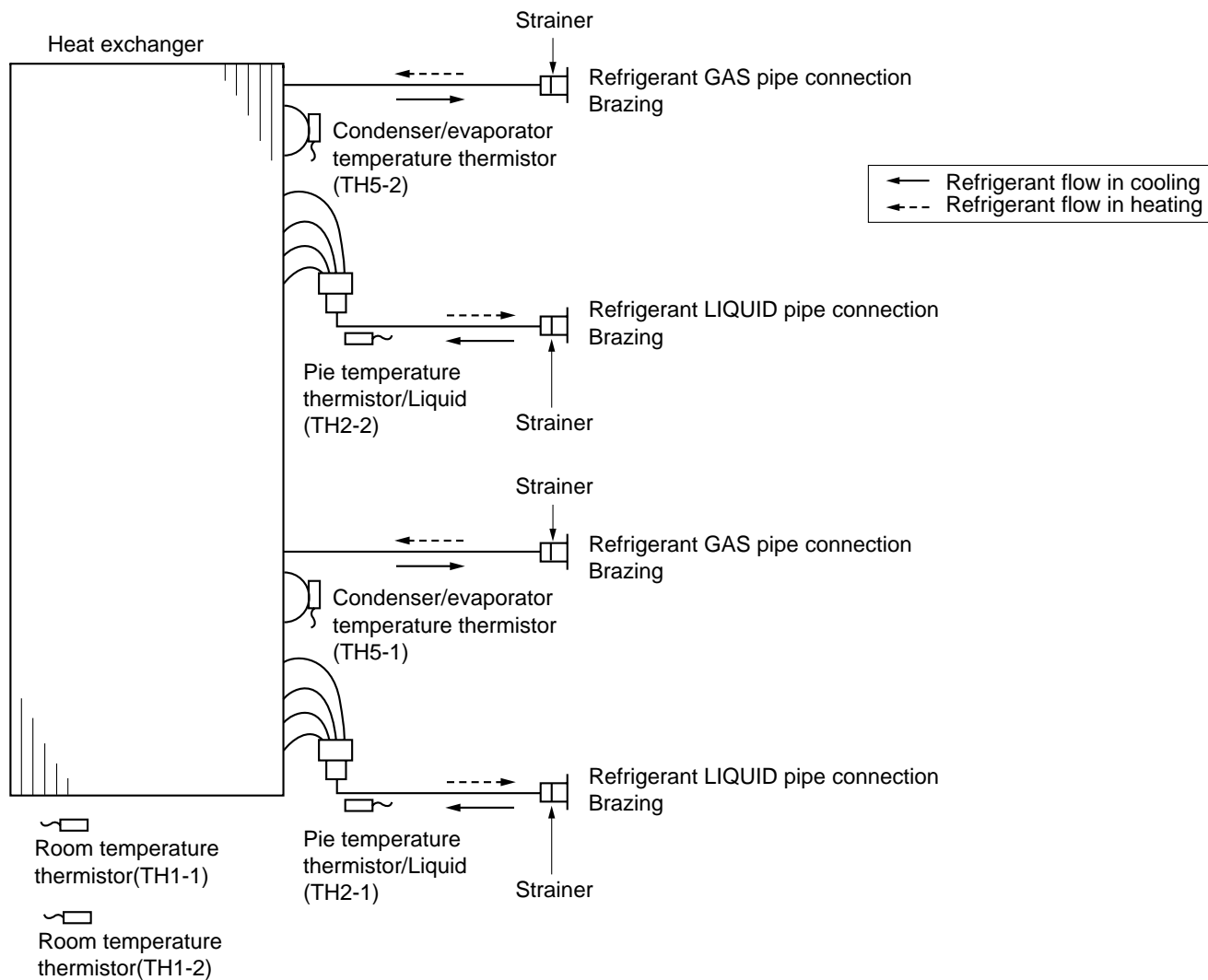

5-2. OUTDOOR UNIT

PUHZ-P100VHA2

Unit : mm

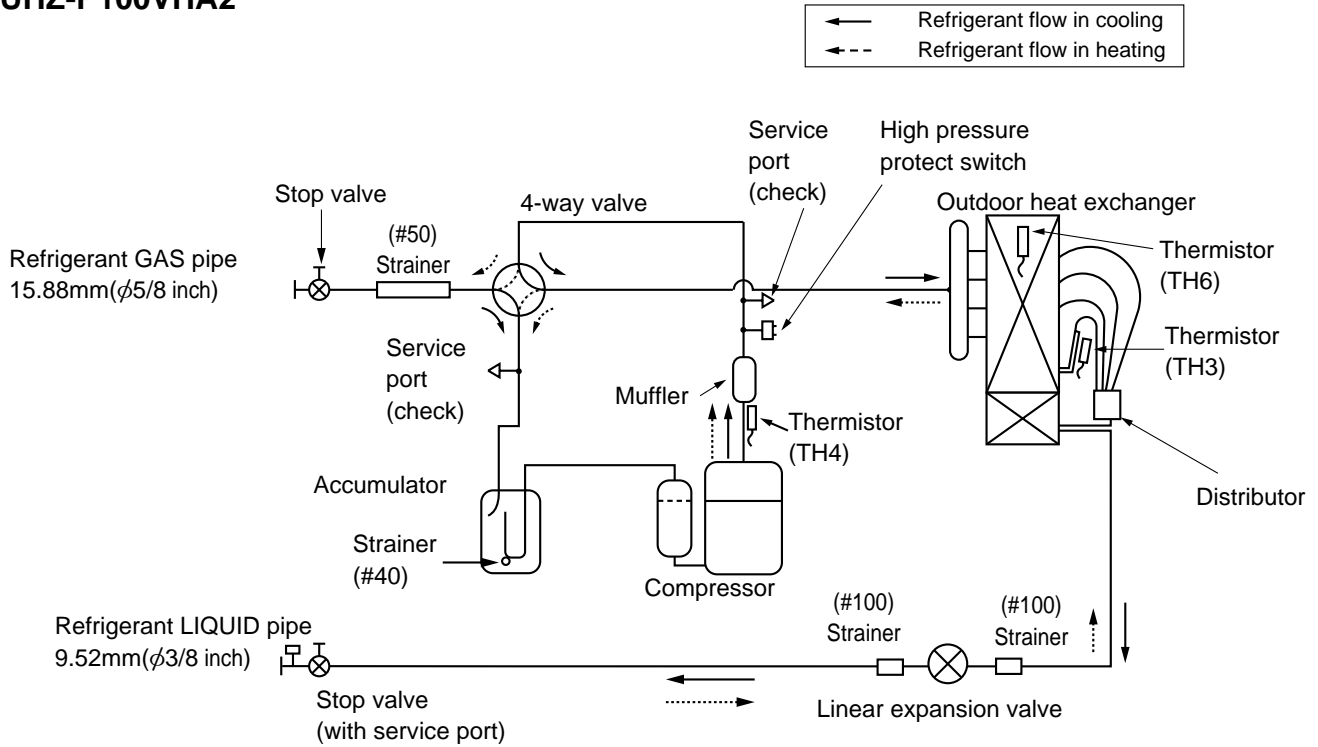

PUHZ-P125VHA2

PUHZ-P140VHA2

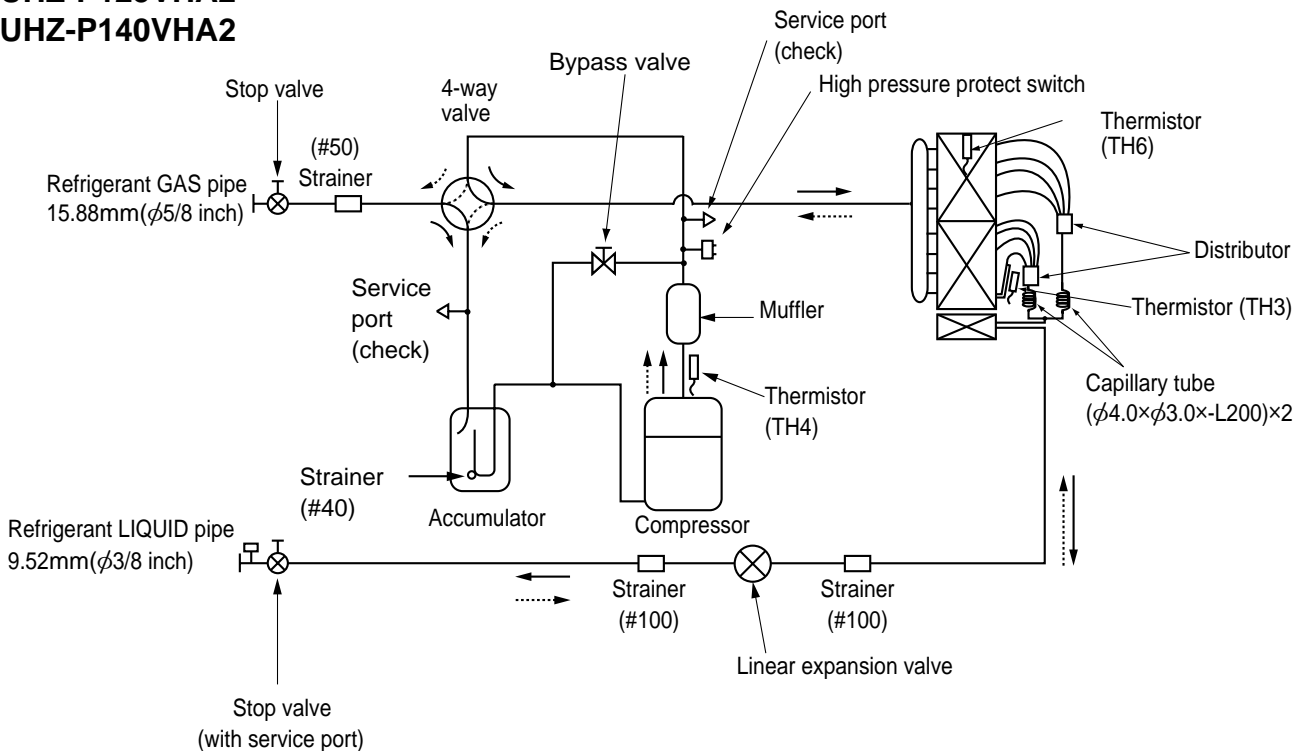

Unit : mm

PUHZ-P200YHA
PUHZ-P250YHA

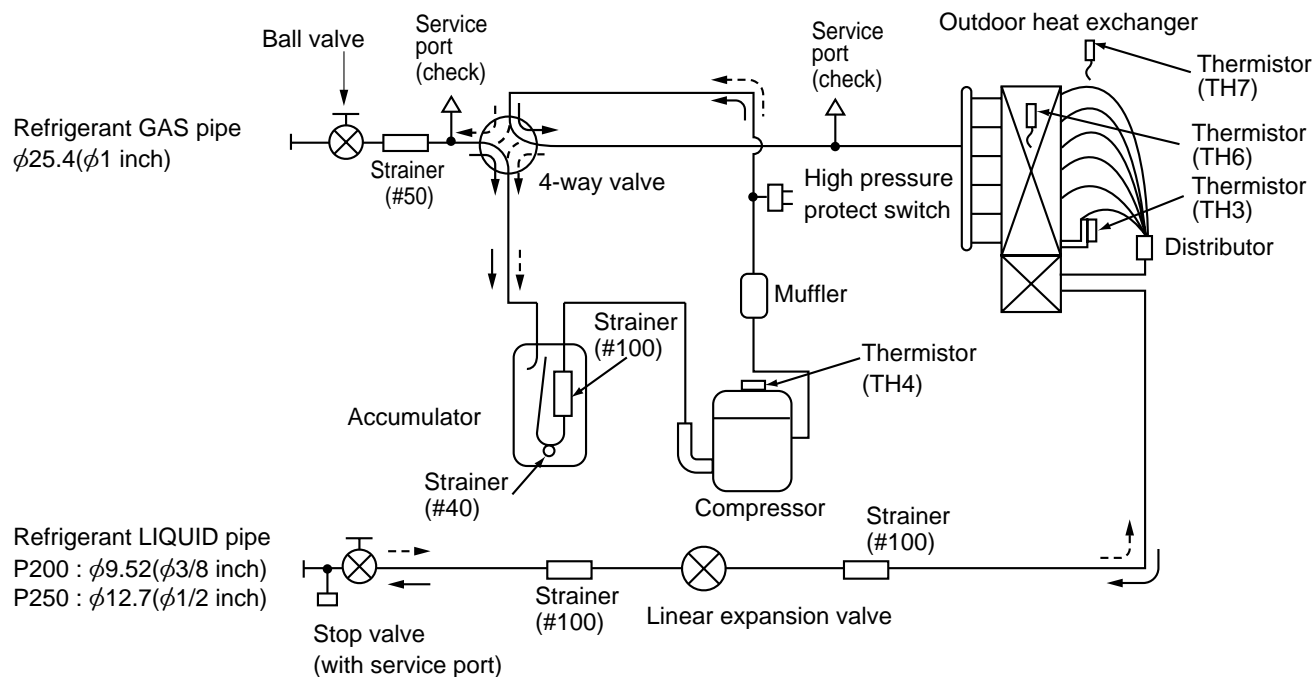
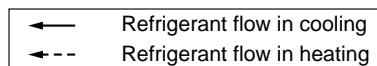

FOR THE COMBINATION OF OUTDOOR UNIT PUHZ-P-VHA2, PUHZ-P-YHA

Cooling capacity

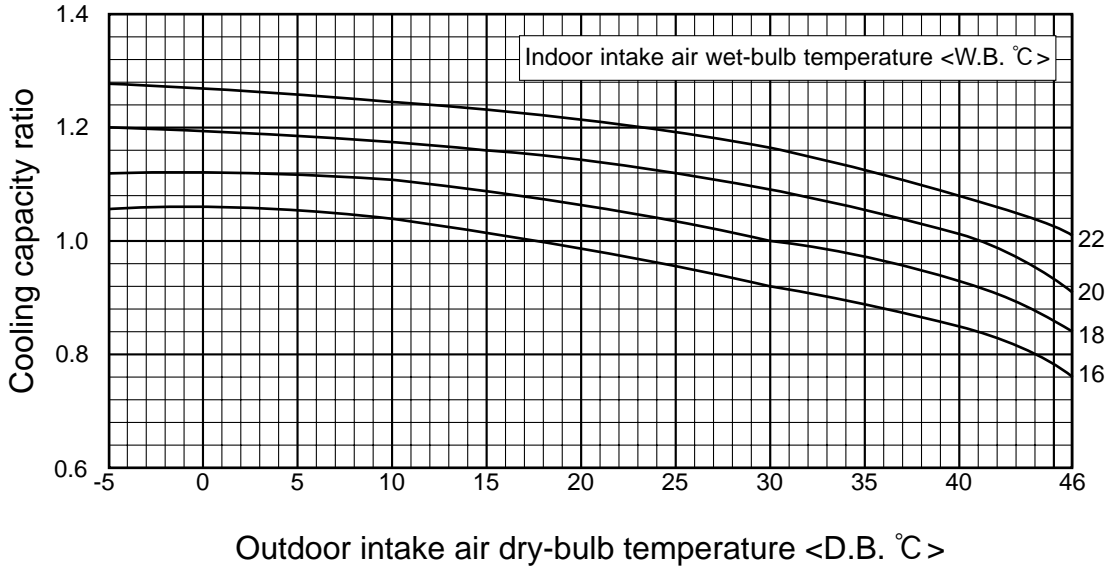

Cooling input

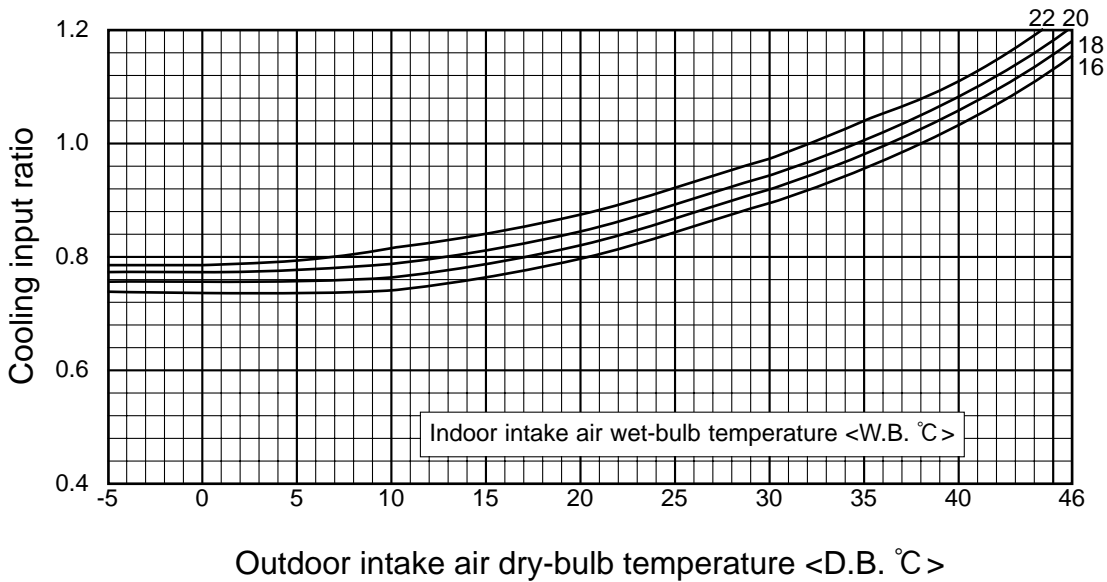

Note : These diagrams show the case where the operation frequency of a compressor is fixed.



Heating capacity

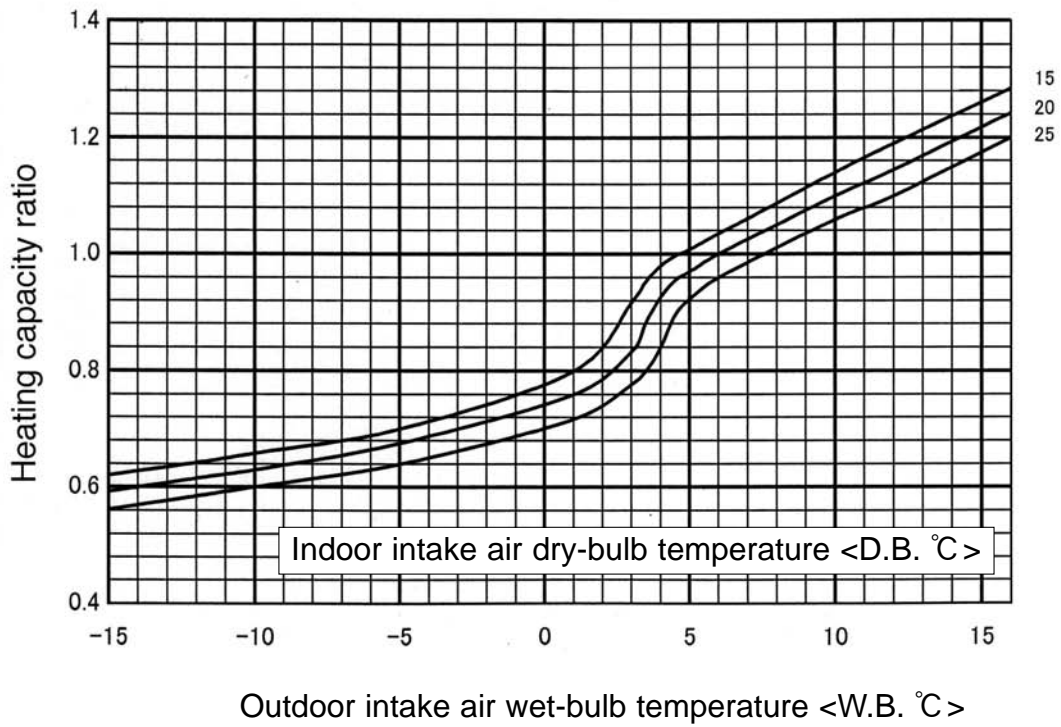

Heating input

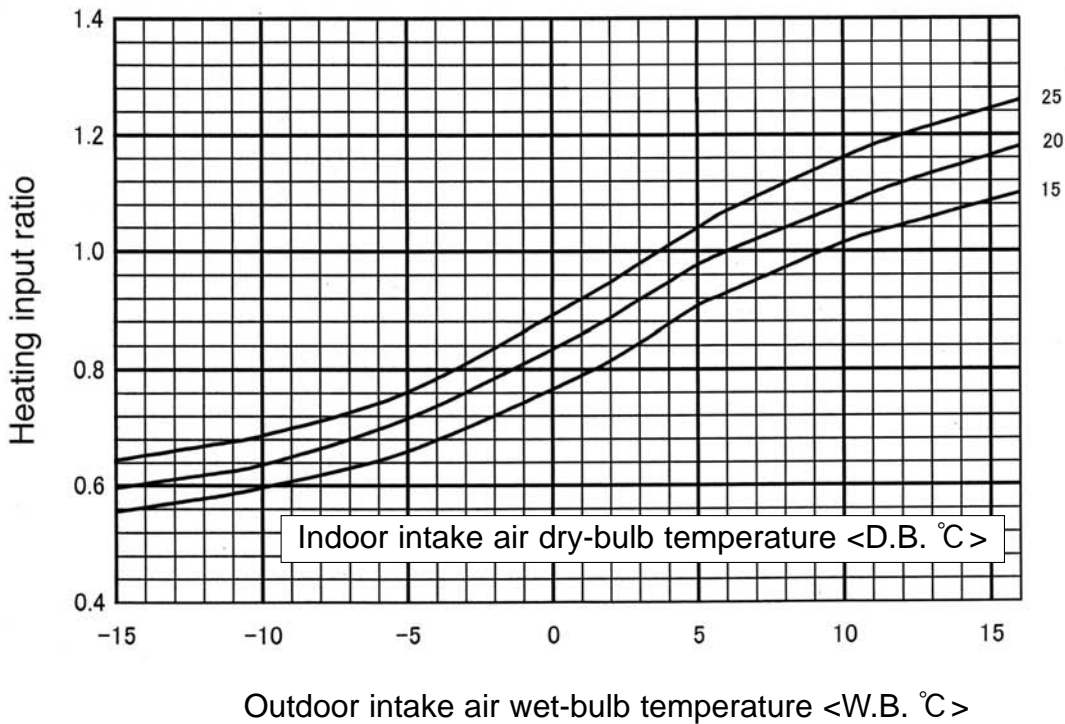

Note : These diagrams show the case where the operation frequency of a compressor is fixed.

PUHZ-P-VHA2 PUHZ-P-YHA

Cooling capacity correction factors

Outdoor unit	Refrigerant piping length (one way)									
	5m	10m	20m	30m	40m	50m	55m	60m	70m	75m
PUHZ-P100VHA2	1.00	0.985	0.957	0.931	0.908	0.886	0.876	—	—	—
PUHZ-P125VHA2	1.00	0.981	0.946	0.914	0.885	0.858	0.845	—	—	—
PUHZ-P140VHA2	1.00	0.976	0.931	0.893	0.858	0.827	0.813	—	—	—
PUHZ-P200YHA	1.00	0.985	0.958	0.931	0.908	0.887	0.876	0.865	0.847	0.838
PUHZ-P250YHA	1.00	0.981	0.946	0.914	0.885	0.858	0.845	0.834	0.812	0.802

Heating capacity correction factors

Outdoor unit	Refrigerant piping length (one way)									
	5m	10m	20m	30m	40m	50m	55m	60m	70m	75m
PUHZ-P100VHA2	1.00	0.997	0.991	0.985	0.979	0.973	0.970	—	—	—
PUHZ-P125VHA2	1.00	0.997	0.991	0.985	0.979	0.973	0.970	—	—	—
PUHZ-P140VHA2	1.00	0.997	0.991	0.985	0.979	0.973	0.970	—	—	—
PUHZ-P200YHA	1.00	0.997	0.991	0.985	0.979	0.973	0.970	0.967	0.961	0.958
PUHZ-P250YHA	1.00	0.997	0.991	0.985	0.979	0.973	0.970	0.967	0.961	0.958

8-1. PIPE LENGTH

8-1-1. 1:1 SYSTEM and 1:2(1 indoor / 2 outdoor) SYSTEM

<Table 1-1> Maximum pipe length (P100-140)

Liquid pipe (mm)	OD	ø9.52			ø12.7	
	Thickness	t0.8			t0.8	
Gas pipe (mm)	OD	ø12.7	ø15.88	ø19.05	ø15.88	ø19.05
	Thickness	t0.8	t1.0	t1.0	t1.0	t1.0
P100	Liquid pipe	Standard size 50m [20m]	○	○	△	△
	Gas pipe		50m [20m]	50m [20m]	25m [10m]	25m [10m]
P125,P140	Liquid pipe	Standard size 50m [30m]	○	○	△	△
	Gas pipe		50m [30m]	50m [30m]	30m [10m]	30m [10m]

<Marks in the table>

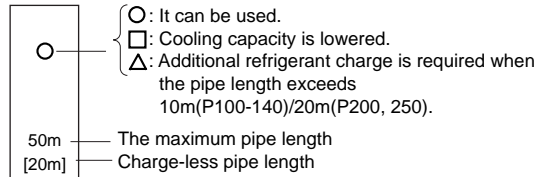

<Table 1-2> Maximum pipe length (P200, 250)

Liquid pipe (mm)	OD	ø9.52			ø12.7			ø15.88			
	Thickness	t0.8			t0.8			t1.0			
Gas pipe (mm)	OD	ø22.2	ø25.4	ø28.58	ø22.2	ø25.4	ø28.58	ø22.2	ø25.4	ø28.58	ø31.75
	Thickness	t1.0	t1.0	t1.0	t1.0	t1.0	t1.0	t1.0	t1.0	t1.0	t1.0
P200	Liquid pipe	□	Normal piping	○	□△	○	○	□△	△	△	△
	Gas pipe	50m [30m]	70m [30m]	70m [30m]	50m [20m]	50m [20m]	50m [20m]	40m [20m]	40m [20m]	40m [20m]	40m [20m]
P250	Liquid pipe	□	○	○	□	Normal piping	○	□△	△	△	△
	Gas pipe	50m [30m]	70m [30m]	70m [30m]	50m [30m]	70m [30m]	70m [30m]	45m [20m]	45m [20m]	45m [20m]	45m [20m]

Note : Be sure to use hard (tempered) one for pipe over ø22.2.(Do not use soft (annealed) one.)

8-1-2. TWIN TRIPLE AND QUADRUPLE SYSTEM

(1) TWIN SYSTEM

<Table 2-1> Maximum pipe length(P100-140)

Main pipe (mm) [A]	Liquid pipe	P100(RP50×2)			P125(RP60×2)-P140(RP71×2)		
		ø9.52	ø9.52	ø12.7	ø9.52	ø9.52	ø12.7
Branch pipe (mm) [B, C]	Gas pipe	P100(RP50×2)			P125(RP60×2)-P140(RP71×2)		
		ø15.88	ø19.05	ø19.05	ø15.88	ø19.05	ø19.05
Liquid pipe	ø6.35	Standard size 50m [20m]	○	△	Standard size 50m [30m]	Standard size 50m [30m]	Standard size 50m [30m]
	ø12.7		50m [20m]	25m [10m]			
Gas pipe	ø9.52	○	○	△	Standard size 50m [30m]	○	△
	ø15.88	50m [20m]	50m [20m]	25m [10m]	50m [30m]	50m [30m]	30m [10m]

<Table 2-2> Maximum pipe length(P200, 250)

Main pipe (mm) [A]	Liquid pipe	O.D.	P200(RP100×2)						P250(RP125×2)												
			ø9.52			ø12.7			ø15.88			ø9.52			ø12.7			ø15.88			
Branch pipe (mm) [B, C]	Gas pipe	ø15.88	P200(RP100×2)						P250(RP125×2)												
			ø22.2	ø25.4	ø28.58	ø22.2	ø25.4	ø28.58	ø22.2	ø25.4	ø28.58	ø31.75	ø22.2	ø25.4	ø28.58	ø22.2	ø25.4	ø28.58	ø31.75		
Liquid pipe	ø9.52	□	Standard size 50m [30m]	○	○△	△	△	○△	△	△	△	□	○	○	□	Standard size 70m [30m]	○	○△	△	△	△
	ø15.88	50m [30m]	70m [30m]	70m [30m]	50m [20m]	50m [20m]	50m [20m]	40m [20m]	40m [20m]	40m [20m]	40m [20m]	50m [30m]	70m [30m]	70m [30m]	50m [30m]	70m [30m]	70m [30m]	45m [20m]	45m [20m]	45m [20m]	45m [20m]

(2) TRIPLE SYSTEM

<Table 3-1> Maximum pipe length(P140)

Main pipe (mm) [A]	Liquid pipe	P140(RP50×3)		
		ø9.52	ø9.52	ø12.7
Branch pipe (mm) [B, C, D]	Gas pipe	P140(RP50×3)		
		ø15.88	ø19.05	ø19.05
Liquid pipe	ø6.35	Standard size 50m [30m]	○	△
	ø12.7		50m [30m]	30m [10m]
Gas pipe	ø9.52	○	○	△
	ø15.88	50m [30m]	50m [30m]	30m [10m]

<Table 3-2> Maximum pipe length(P200, 250)

Main pipe (mm) [A]	Liquid pipe	O.D.	P200(RP60×3)						P250(RP71×3)												
			ø9.52			ø12.7			ø15.88			ø9.52			ø12.7			ø15.88			
Branch pipe (mm) [B, C]	Gas pipe	ø15.88	P200(RP60×3)						P250(RP71×3)												
			ø22.2	ø25.4	ø28.58	ø22.2	ø25.4	ø28.58	ø22.2	ø25.4	ø28.58	ø31.75	ø22.2	ø25.4	ø28.58	ø22.2	ø25.4	ø28.58	ø31.75		
Liquid pipe	ø9.52	□	Standard size 50m [30m]	○	○△	△	△	○△	△	△	△	□	○	○	□	Standard size 70m [30m]	○	○△	△	△	△
	ø15.88	50m [30m]	70m [30m]	70m [30m]	50m [20m]	50m [20m]	50m [20m]	40m [20m]	40m [20m]	40m [20m]	40m [20m]	50m [30m]	70m [30m]	70m [30m]	50m [30m]	70m [30m]	70m [30m]	45m [20m]	45m [20m]	45m [20m]	45m [20m]

(3) QUADRUPLE SYSTEM

<Table 2-2> Maximum pipe length(P200, 250)

Main pipe (mm) [A]	Liquid pipe	O.D.	P200(RP50x4)										P250(RP60x4)									
			φ9.52			φ12.7			φ15.88				φ9.52			φ12.7			φ15.88			
			Thickness	t1.0	t1.0	t1.0	t1.0	t1.0	t1.0	t1.0	t1.0	t1.1	t1.0	t1.0	t1.0	t1.0	t1.0	t1.0	t1.0	t1.0	t1.1	
Branch pipe (mm) [B,C]	Liquid pipe	φ6.35	□	○	○	□△	△	△	□△	△	△	△	△	△	△	△	△	△	△	△	△	
	Gas pipe	φ12.7	50m [30m]	70m [30m]	70m [30m]	50m [20m]	50m [20m]	50m [20m]	40m [20m]	40m [20m]	40m [20m]	40m [20m]	40m [20m]	40m [20m]	40m [20m]	40m [20m]	40m [20m]	40m [20m]	40m [20m]	40m [20m]	40m [20m]	
	Liquid pipe	φ9.52	□	○	○	□△	△	△	□△	△	△	△	△	△	△	△	△	△	△	△	△	
	Gas pipe	φ15.88	50m [30m]	70m [30m]	70m [30m]	50m [20m]	50m [20m]	50m [20m]	40m [20m]	40m [20m]	40m [20m]	40m [20m]	40m [20m]	50m [30m]	70m [30m]	70m [30m]	50m [30m]	Standard size 70m [30m]	70m [30m]	45m [20m]	45m [20m]	45m [20m]

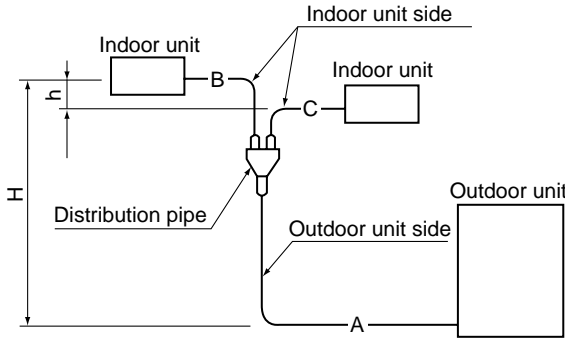

<TWIN SYSTEM>
Total length A + B + C
P100-140: 50 m
P200, 250: 70 m

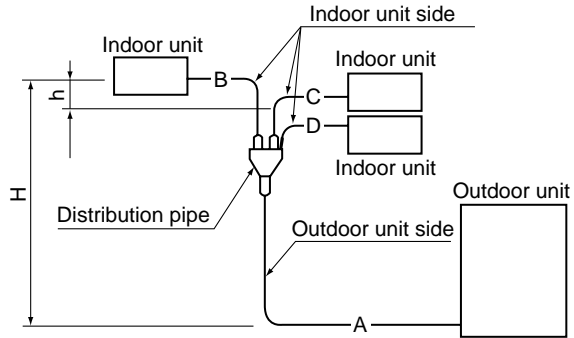

<TRIPLE SYSTEM>
Total length A + B + C + D
P140: 50 m
P200, 250: 70 m

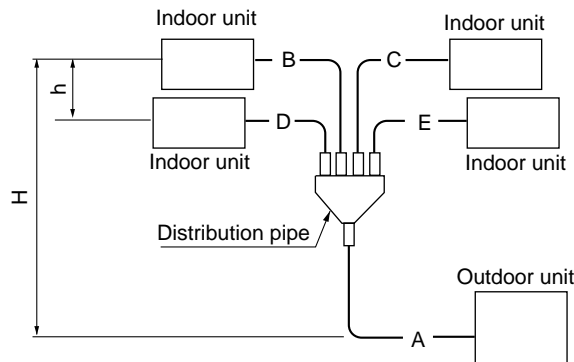

<QUADRUPLE SYSTEM>
Total length A + B + C + D + E
P200, 250 : 70 m

(4) Pipe size and refrigerant pipe limits

	Outdoor unit	Pipe size (mm)				Actual piping length <m>			Height deffence <m>		(Note 1) No. of bend									
		Gas side		Liquid side		Total length A+B+C+D+E	Indoor ~ Indoor	Branch pipe B, C, D	Indoor ~ Outdoor	Indoor ~ Indoor										
		Outdoor unit side	Indoor unit side	Outdoor unit side	Indoor unit side															
TWIN	100-140	φ15.88 <5/8>	RP50 φ12.7<1/2> RP60,71 φ15.88<5/8>	φ9.52<3/8>	RP50 φ6.35<1/4> RP60,71 φ9.52<3/8>	50m	B-C 8m	20m	H30m	h 1m	15									
TRIPLE	140						B-C C-D B-D 8m													
TWIN	200, 250	φ25.4 <1>	RP60,71 100, 125 φ15.88<5/8>	φ9.52<3/8> φ12.7<1/2> (P250)	RP60,71 100, 125 φ9.52<3/8>	70m	B-C 8m	30m												
TRIPLE																				
QUADRUPLE																				

Note1. The number of bends in the refrigerant pipe is respectively 8 or less in the range of <A+B> <A+C> <A+D>.
2. PUHZ-P100: 20 m chargeless
PUHZ-P125-250: 30 m chargeless

8-2. ADJUSTING THE AMOUNT OF REFRIGERANT

- Check additional refrigerant charging amount referring to table 5, 6 when liquid pipe is one size larger than standard diameter.

<Table 5> Required additional charge when the liquid pipe is one size larger than the standard diameter (1:1 SYSTEM)

	Liquid pipe dia.	Chargeless	Max. pipe length	Refrigerant amount to be added
P100	φ12.7	10m	25m	100 g per 1 m longer than 10 m
P125,140	φ12.7	10m	30m	100 g per 1 m longer than 10 m
P200	φ15.88	20m	40m	Additional refrigerant amount (Longer than 20 m) $\Delta W(g) = 180 \times \text{pipe length}(m) - 3000$
P250	φ15.88	20m	45m	

If the calculation produces a negative number ($\Delta W \leq 0$), additional charging is not necessary.

<Table 6> Required additional charge when the liquid pipe is one size larger than the standard diameter (TWIN/TRIPLE/QUADRUPLE SYSTEM)

Capacity	When the extension pipe length (main piping + branch piping) exceeds 10 m(P100-140)/20m(P200, 250)
P100,125,140	Additional refrigerant amount $\Delta W(g) = (100 \times L2) + (60 \times L3) + (30 \times L4) - 2000$
P200, 250	Additional refrigerant amount $\Delta W(g) = (180 \times L1) + (120 \times L2) + (90 \times L3) + (30 \times L4) - 3000$

If the calculation produces a negative number ($\Delta W \leq 0$), additional charging is not necessary.

L1: φ15.88 liquid pipe length (m) L2: φ12.7 liquid pipe length (m)
L3: φ9.52 liquid pipe length (m) L4: φ6.35 liquid pipe length (m)

<Table 7> Additional refrigerant charging amount for pipe of standard diameter

Outdoor unit	Max. pipe length	Amount of unit filling refrigerant (kg)	Additional refrigerant charging amount for pipe length exceeding 30 m (kg)				
			21 — 30m	31 — 40m	41 — 50m	51 — 60m	61 — 70m
PUHZ-P100VHA2	50m	3.0kg	0.6kg	1.2kg	1.8kg	/	/
PUHZ-P125VHA2	50m	4.5kg	/	0.6kg	1.2kg		
PUHZ-P140VHA2	50m	4.5kg	/	0.6kg	1.2kg		
PUHZ-P200YHA	70m	5.8kg	/	0.9kg	1.8kg	2.7kg	3.6kg
PUHZ-P250YHA	70m	7.1kg	/	1.2kg	2.4kg	3.6kg	4.8kg

8-3. CAPACITY CURVE

■ PUAZ-P100, 125, 140 VHA2<Standard size>

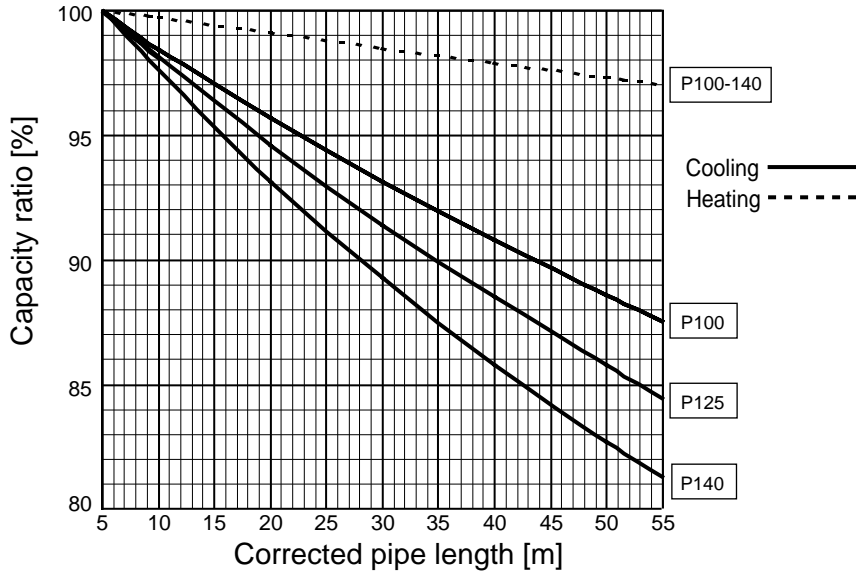

■ PUAZ-P200, 250YHA<Standard size>

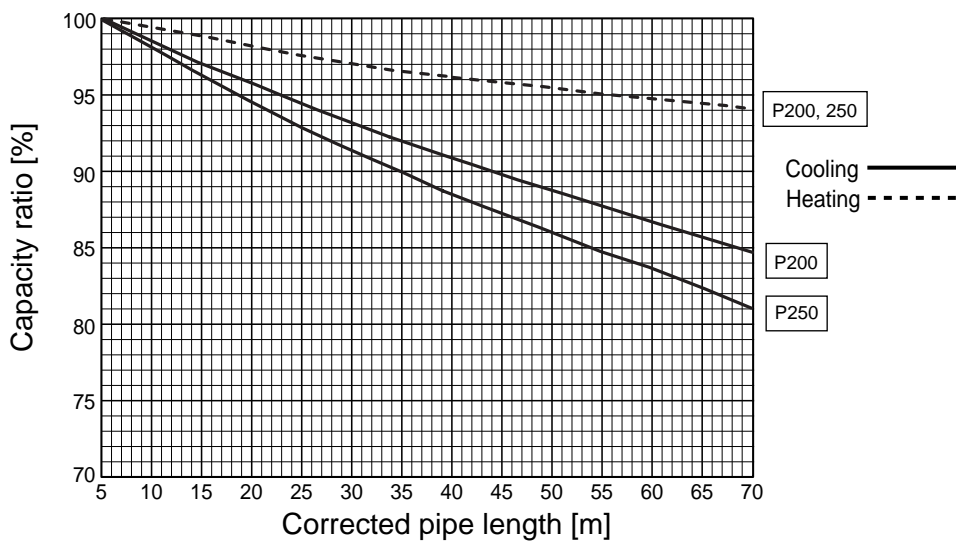

■ PUAZ-P200, 250YHA<Gas pipe's diameter is one size smaller than the standard size.>

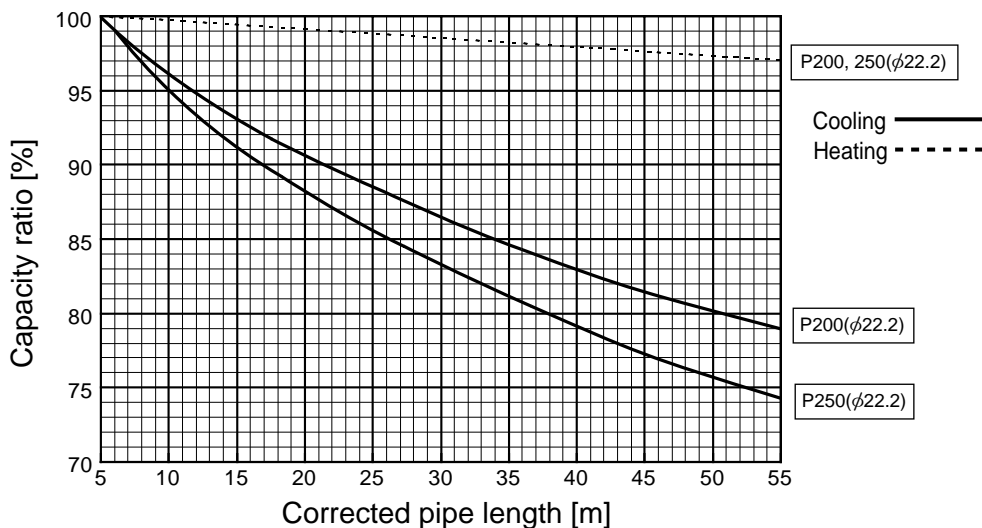

9

AIR FLOW DATA

9-1. OUTLET AIR SPEED AND COVERAGE RANGE

		PLA-RP50BA	PLA-RP60BA	PLA-RP71BA	PLA-RP100BA	PLA-RP125BA	PLA-RP140BA
Airflow	m ³ /min.	18	18	21	30	31	32
Air speed	m/sec.	3.2	3.2	3.7	5.3	5.4	5.6
Coverage range	m	4.8	4.8	5.6	8.0	8.2	8.5

		PCA-RP50GA	PCA-RP50GA2 PCA-RP60GA	PCA-RP71GA	PCA-RP100GA	PCA-RP125GA	PCA-RP140GA
Airflow	m ³ /min	13	18	18	25	34	34
Air speed	m/sec	3.7	3.8	3.8	4.1	4.4	4.4
Coverage range	m	8.8	10.4	10.4	12.6	15.2	15.2

		PCA-RP71HA	PCA-RP125HA
Airflow	m ³ /min	19	38
Air speed	m/sec	2.9	4.2
Coverage range	m	7.9	13.2

		PKA-RP50GAL
Airflow	m ³ /min	12
Air speed	m/sec	5.3
Coverage range	m(ft)	10(32.8)

		PKA-RP50FAL2 PKA-RP60FAL	PKA-RP71FAL	PKA-RP100FAL
Airflow	m ³ /min	20	20	28
Air speed	m/sec	4.9	4.9	5.4
Coverage range	m(ft)	12.4(40.7)	12.4(40.7)	15.3(50.2)

		PSA-RP71GA	PSA-RP100GA	PSA-RP125GA	PSA-RP140GA
Airflow	m ³ /min	18	31	33	35
Air speed	m/sec	2.6	4.5	4.8	4.9
Coverage range	m	8.3	14.3	15.2	16.1

* The air coverage range is the distance to which the 0.25m/sec air can reach, when air is blown out horizontally from the unit at the High notch position.

The coverage range should be used only as a general guideline since it varies according to the size of the room and the furniture inside the room.

9-2. PLA-RP-BA

9-2-1 FRESH AIR INTAKE AND BRANCH DUCT

1. Branch duct hole and fresh air intake hole (Fig. 1)

At the time of installation, use the duct holes (cut out) located at the positions shown in Fig.1, as and when required.

- A fresh air intake hole for the optional multi function casement can also be made.

Note:

The figure marked with * in the drawing represent the dimensions of the main unit excluding those of the optional multi function casement.

When installing the optional multi function casement, add 135 mm to the dimensions marked on the figure.

When installing the branch ducts, be sure to insulate adequately.

Otherwise condensation and dripping may occur.

Unit : mm

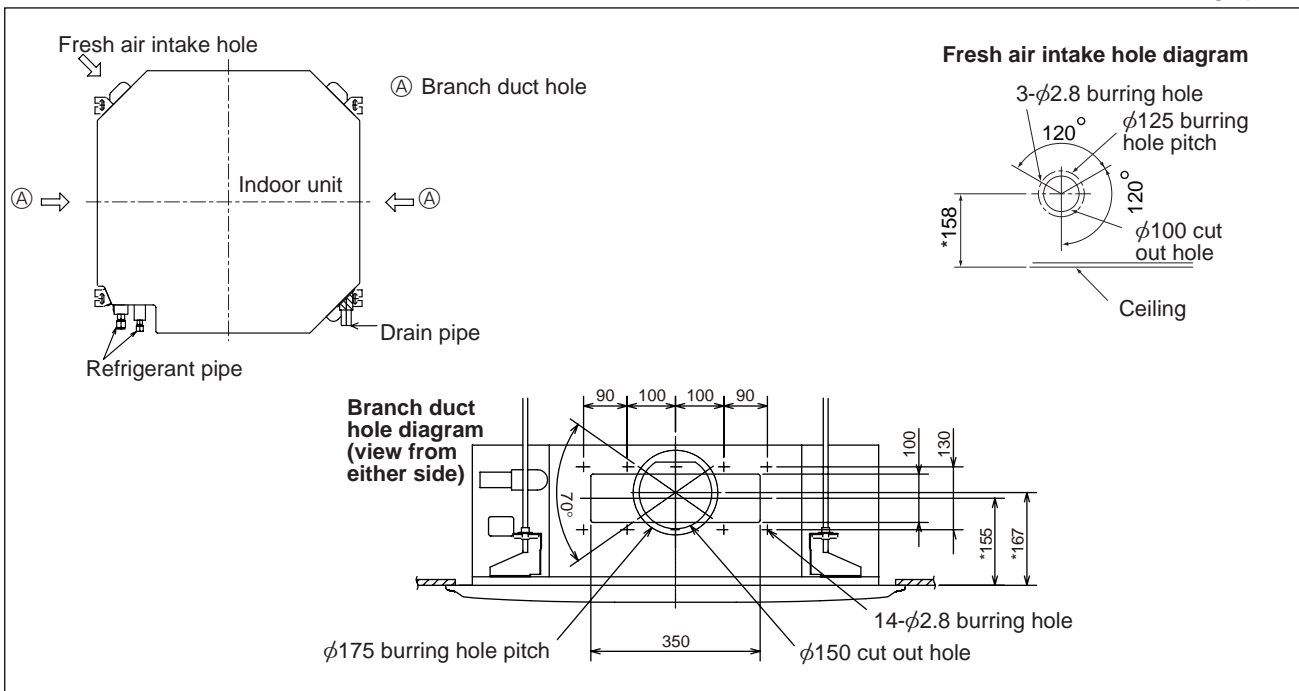
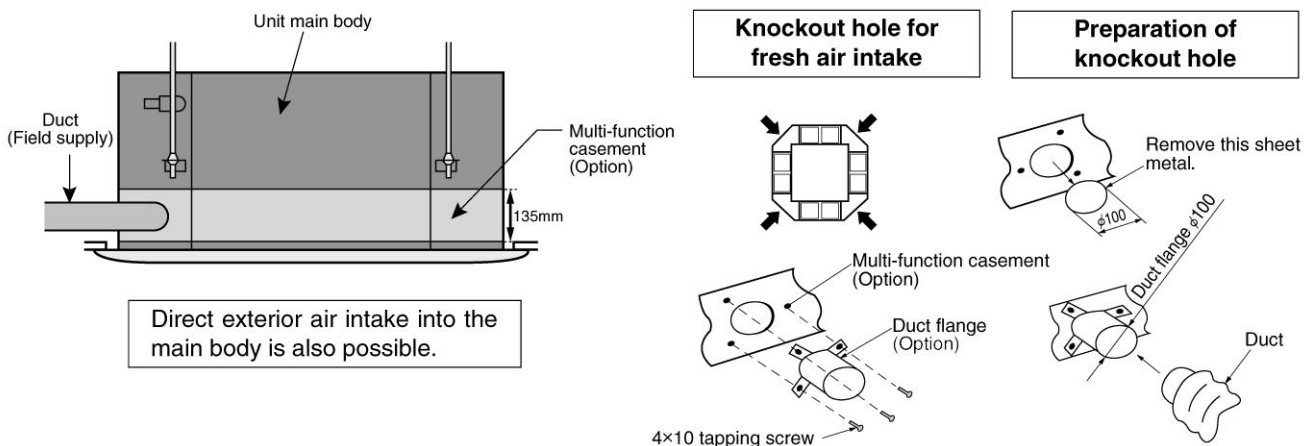

Fig. 1

2. Fresh air intake (Installation at site)

- By mounting the optional multi-function casement to the indoor unit main body, and mounting the duct and duct flange (option) onto it further, fresh exterior air intake can be accomplished.

(The mounting of the multi-function casement increases the height of the ceiling plenum by 135mm.)



3. Fresh air intake volume & static pressure characteristics

PLA-RP50~71BA

① At using multi-function casement, standard filter

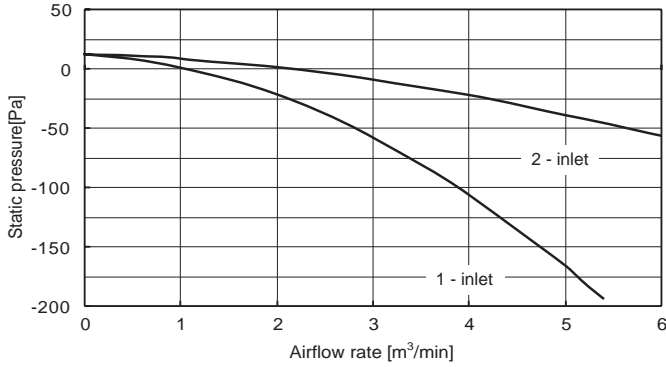

② Direct intake to unit

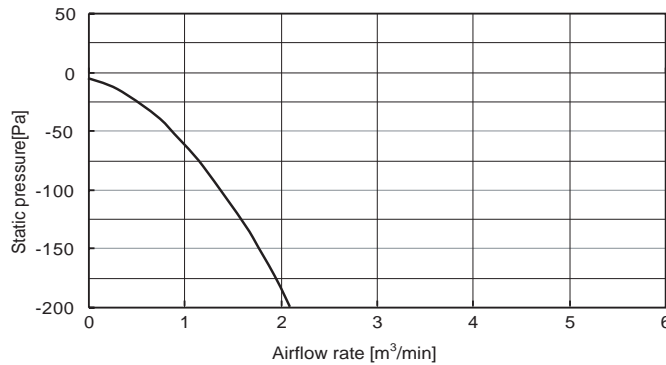

PLA-RP100~140BA

① At using multi-function casement, standard filter

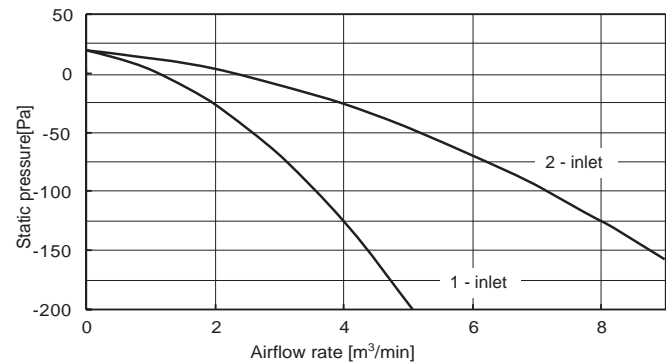

② Direct intake to unit

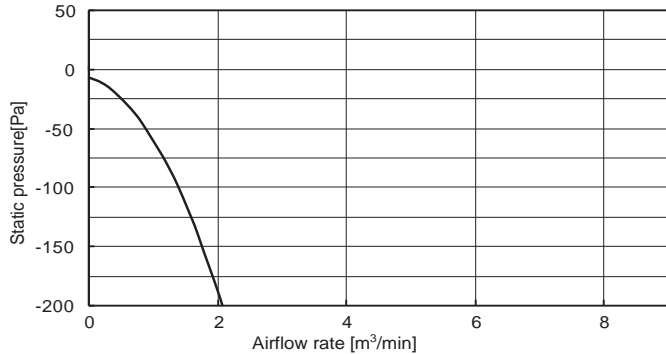

How to read the chart

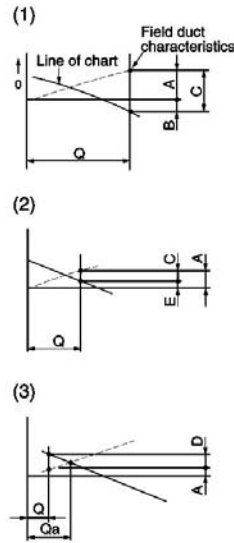

Q Design fresh air intake volume (m³/min)

A Static pressure loss [Pa] of fresh air intake duct at airflow rate of Q

B Required boost pressure [Pa] of air conditioner inlet at airflow rate of Q

C Required static pressure [Pa] of booster fan at airflow rate of Q

D Required compensation [Pa] for static pressure loss of fresh air intake duct to make airflow rate Q

E Static pressure [Pa] of indoor unit at airflow rate of Q

Qa .. Estimated fresh air intake [m³/min] without compensation of D

③ At using multi-function casement, high efficiency filter

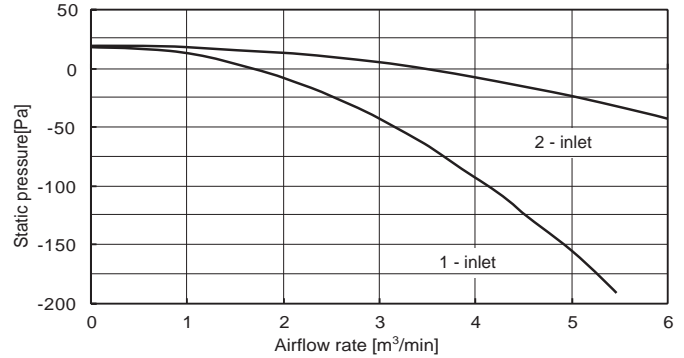

③ At using multi-function casement, high efficiency filter

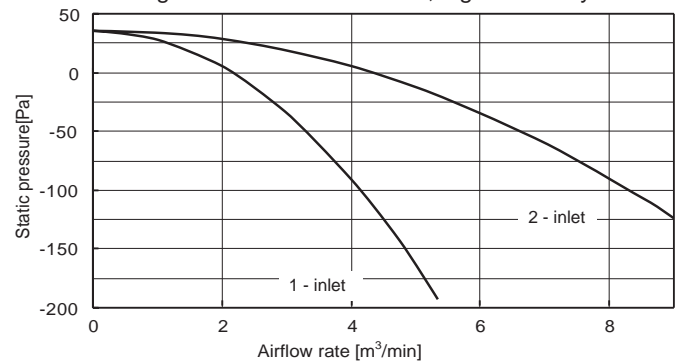

4. Change of outlet numbers

[The optional air outlet is necessary.]
To change the air outlet number to 3-, or 2-way outlet, the outlet number should be closed with the operational air outlet shutter.

(When the air outlets are closed, close the vane by removing the vane connector.)

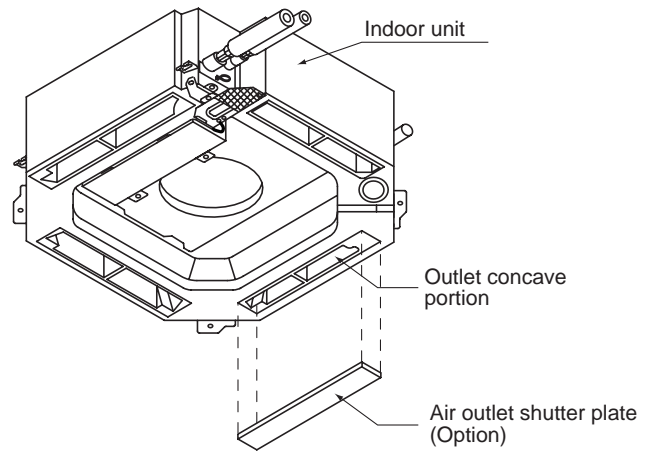
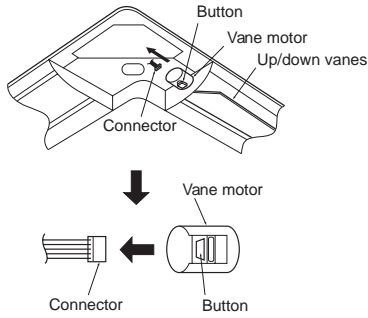

5. Branch duct and change of outlet numbers

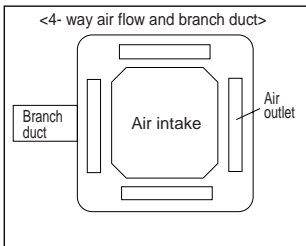

※ Branch duct should be connected to one of the branch duct holes on the main unit.

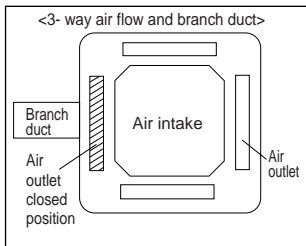

※ Close the outlet on the side of branch duct and air flows in 3 directions.

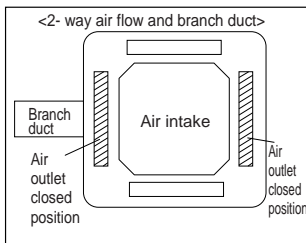

※ Close the outlet on the side of branch duct and one of the other outlets. Air flows in 2 directions.

PLA-RP71BA

● 4-way airflow (horizontal vane) Round duct

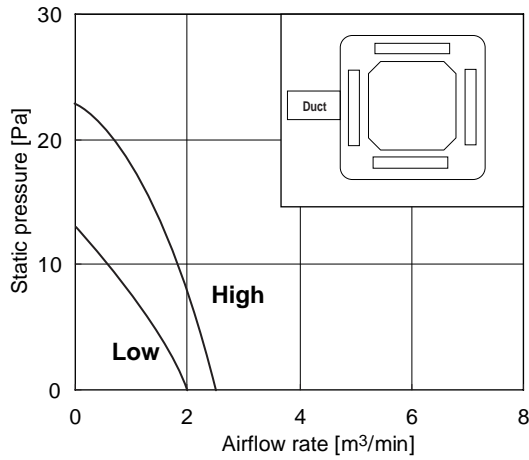

● 4-way airflow (horizontal vane) Rectangular duct

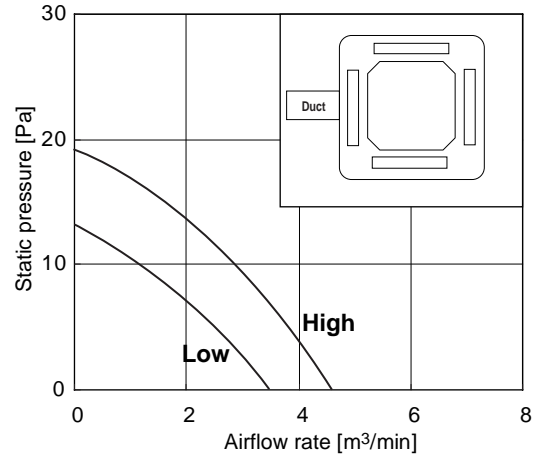

● 3-way airflow (horizontal vane) Round duct

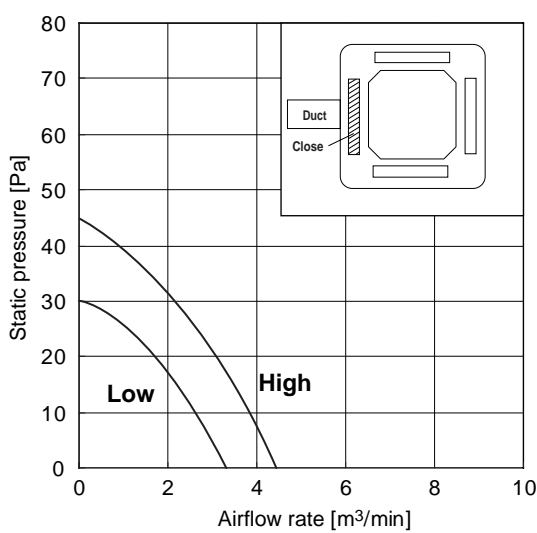

● 3-way airflow (horizontal vane) Rectangular duct

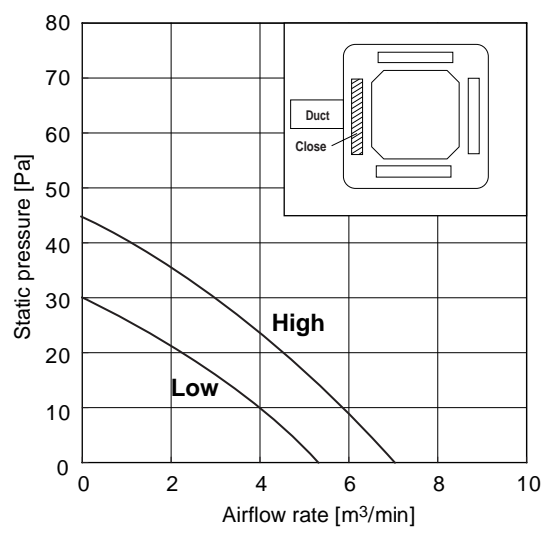

● 2-way airflow (horizontal vane) Round duct

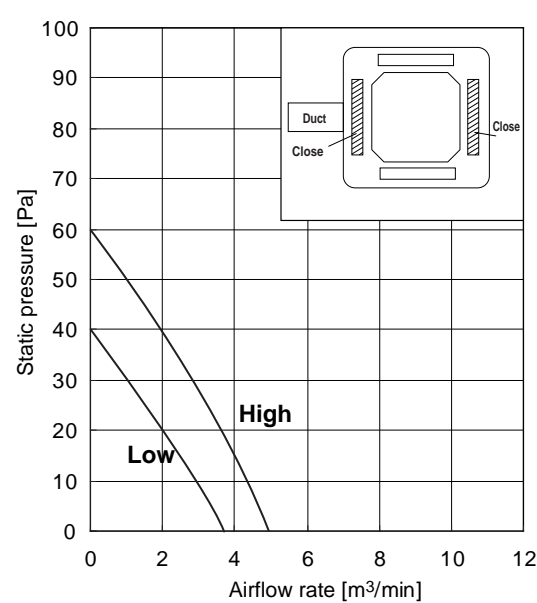

● 2-way airflow (horizontal vane) Rectangular duct

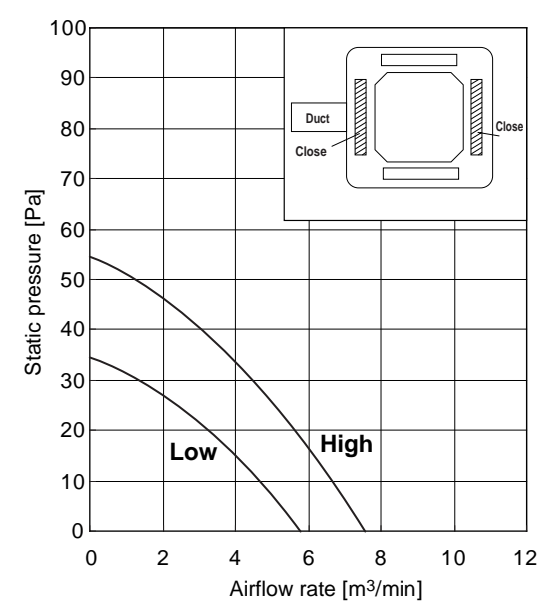

- Use 1 of the 2 duct holes on the indoor unit.
- Airflow rate of PLA-RP50, 60BA can be calculated from the airflow rate based on the characteristic of the duct for PLA-RP71BA.
- Use the optional air outlet shutter plate (PAC-SH51SP-E) for 3-way and 2-way airflow.

PLA-RP125BA

● 4-way airflow (horizontal vane) Round duct

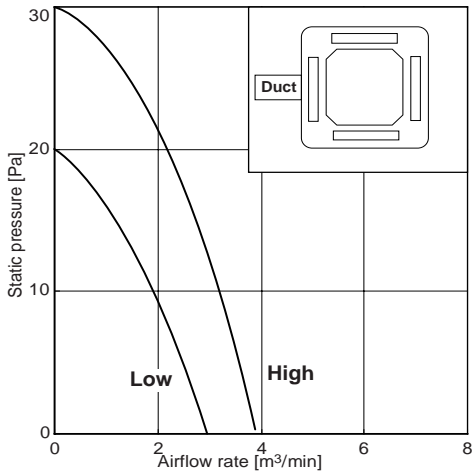

● 4-way airflow (horizontal vane) Rectangular duct

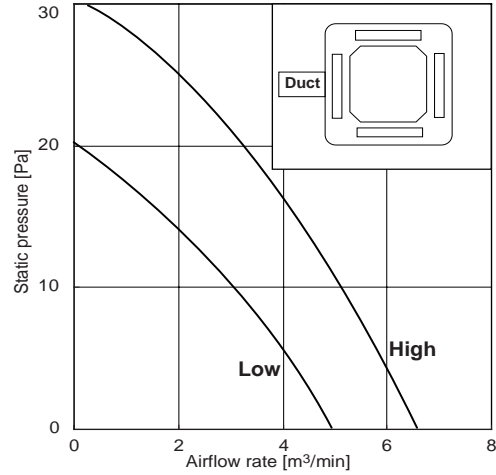

● 3-way airflow (horizontal vane) Round duct

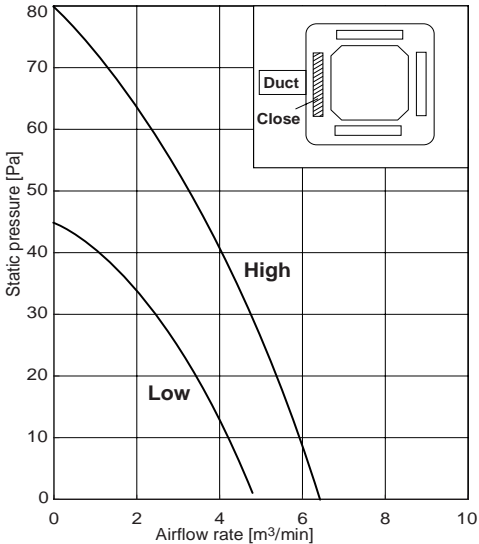

● 3-way airflow (horizontal vane) Rectangular duct

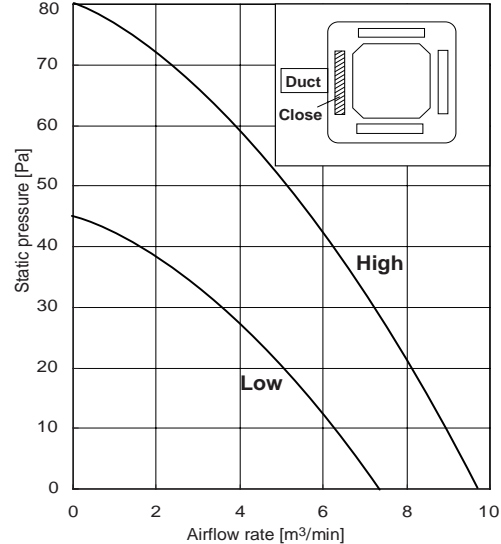

● 2-way airflow (horizontal vane) Round duct

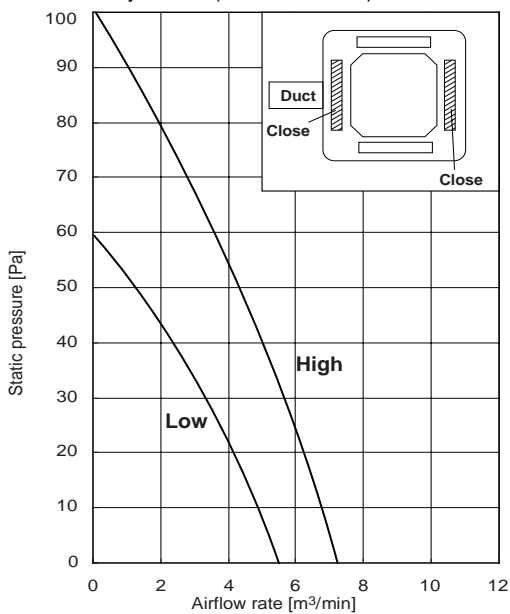

● 2-way airflow (horizontal vane) Rectangular duct

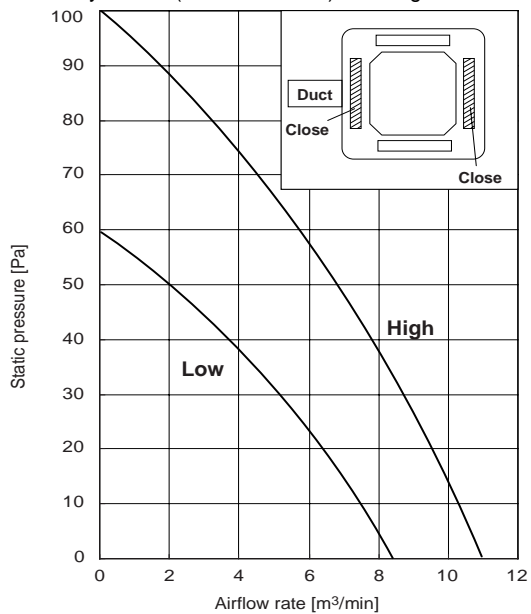

- Use 1 of the 2 duct holes on the indoor unit.
- Airflow rate of PLA-RP100BA, PLA-RP140BA can be calculated PLA from the airflow rate based on the characteristic of the duct for PLA-RP125BA.
- Use the optional air outlet shutter plate (PAC-SH51SP-E) for 3-way and 2-way airflow.

9-3. PEAD-RP-EA,EA2,GA

9-3-1. FAN PERFORMANCE AND CORRECTED AIRFLOW

PEAD-RP50EA

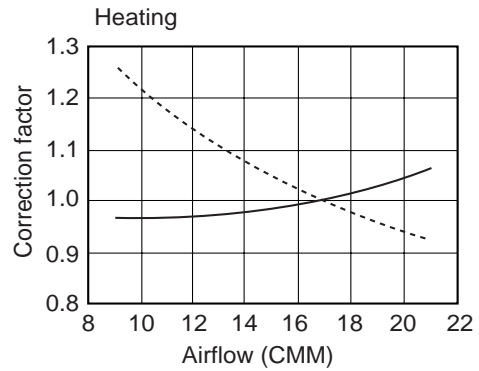
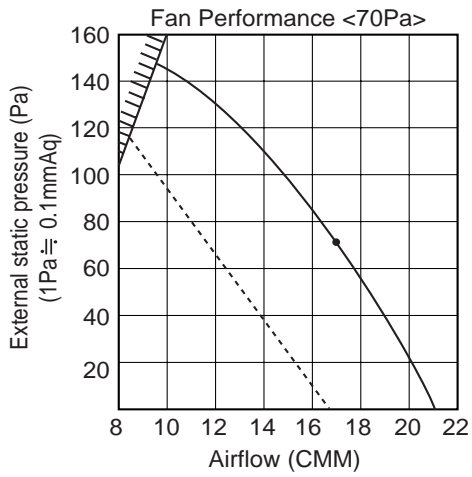
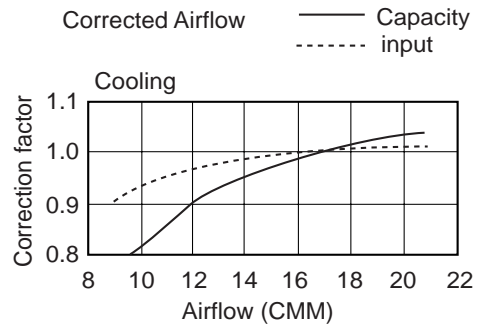
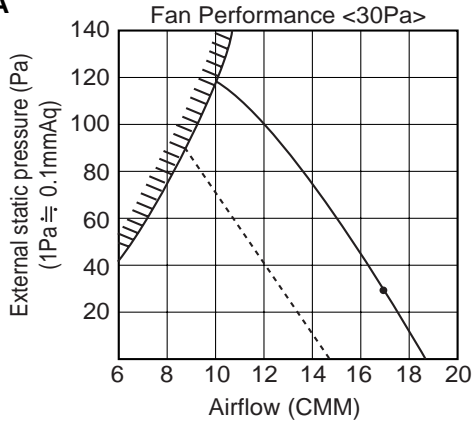

PEAD-RP60EA

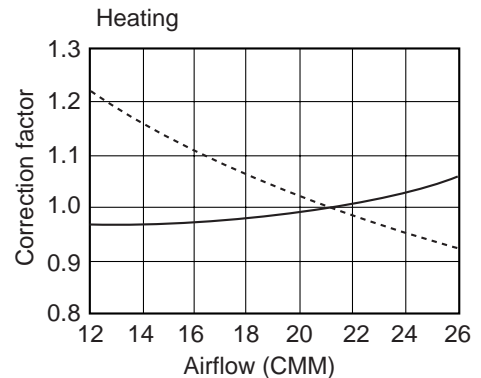
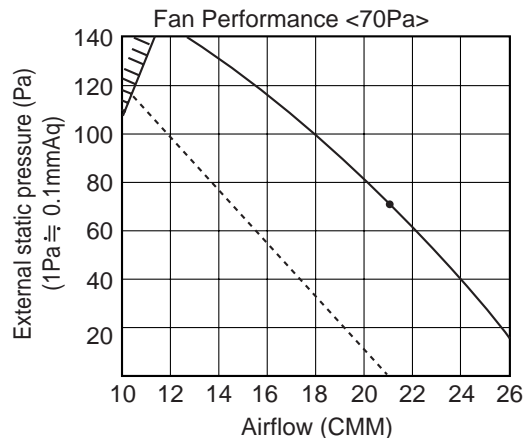
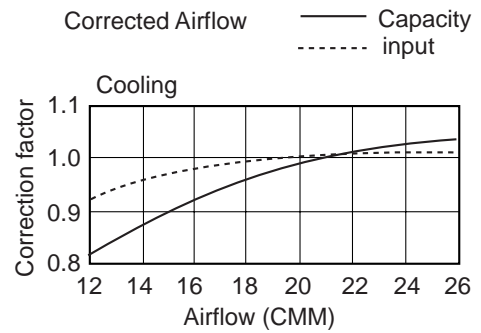
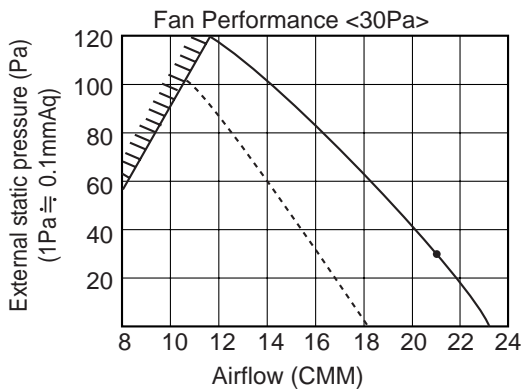

PEAD-RP71EA

Fan performance <130Pa>

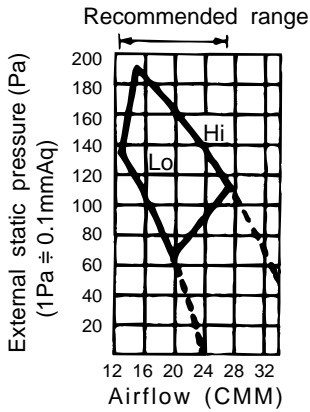

Fan performance <70Pa>

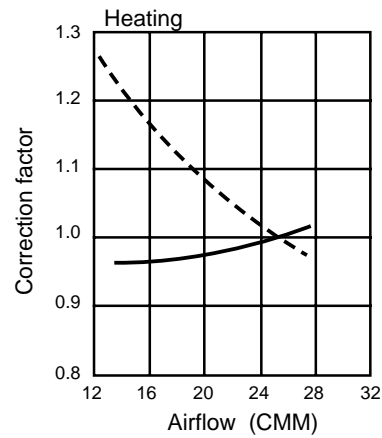
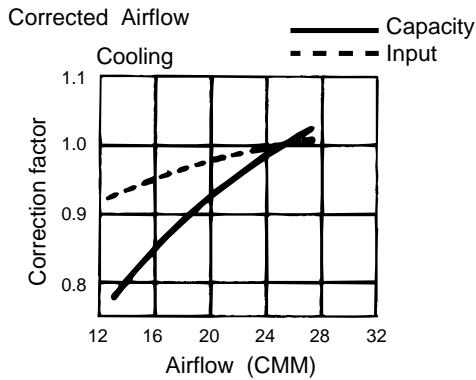
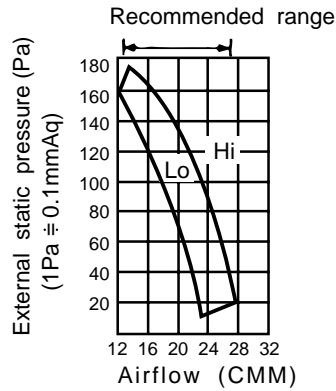

PEAD-RP100EA2
PEAD-RP125EA

Fan performance <130Pa>

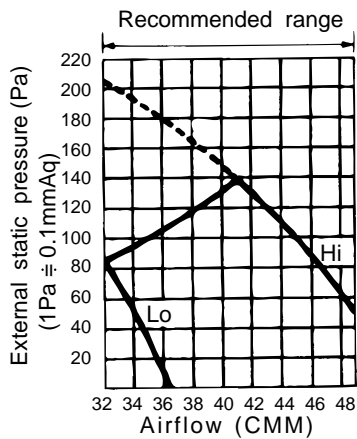

Fan performance <70Pa>

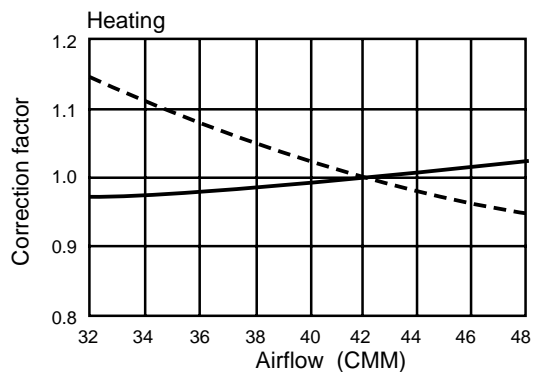
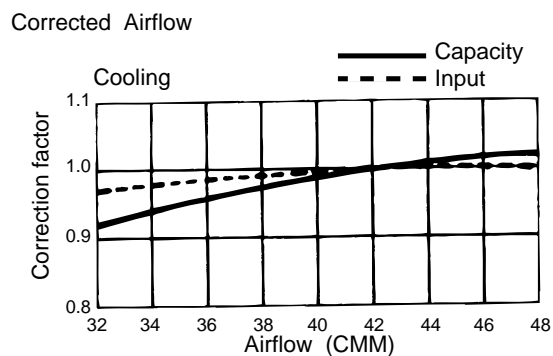
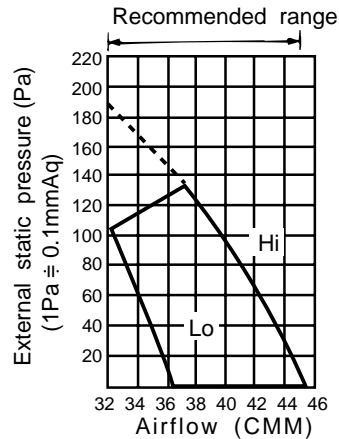

PEAD-RP140EA

Fan performance <130Pa>

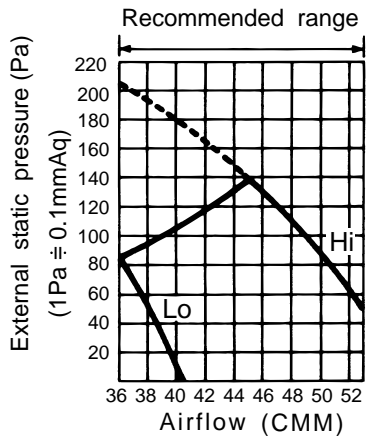

Fan performance <70Pa>

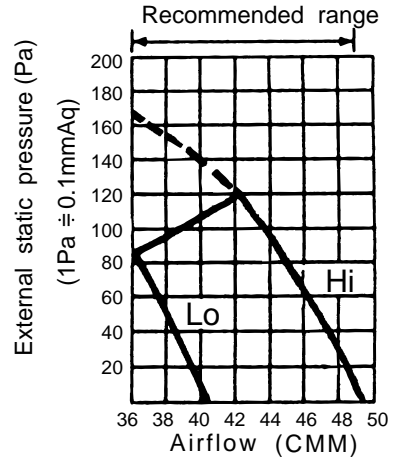

Corrected Airflow

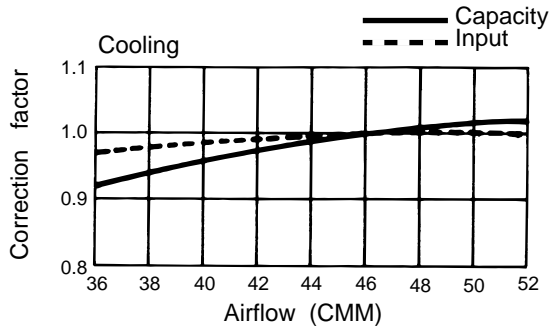

Heating

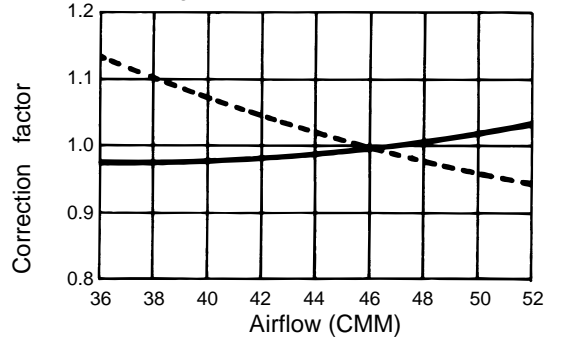

PEAD-RP60GA

Fan performance <220V>

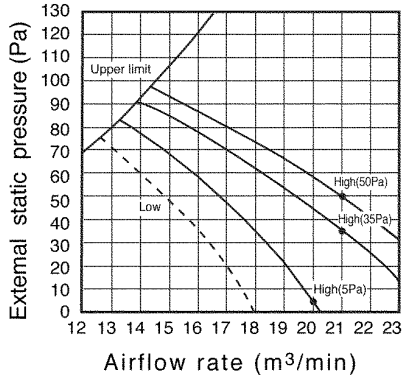

Fan performance <230V>

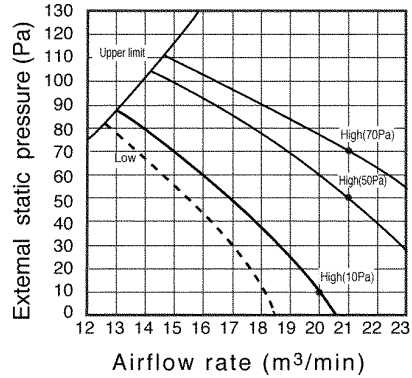

Fan performance <240V>

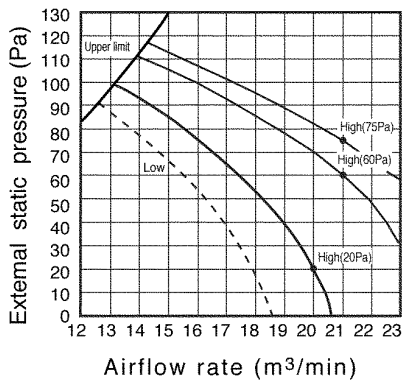

Corrected air flow

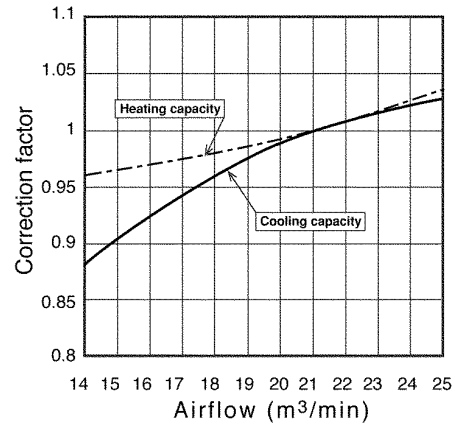

PEAD-RP71GA

Fan performance <220V>

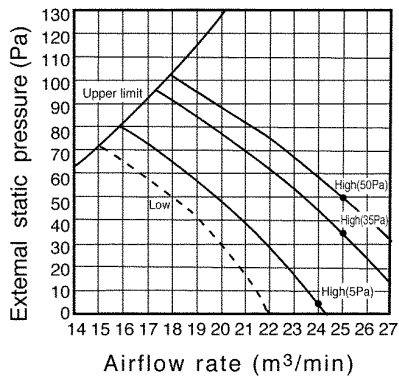

Fan performance <230V>

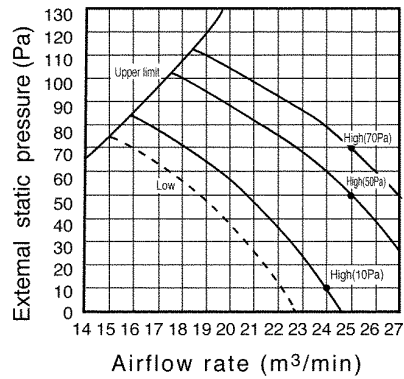

Fan performance <240V>

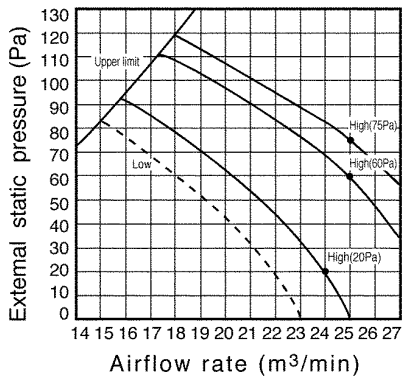

Corrected air flow

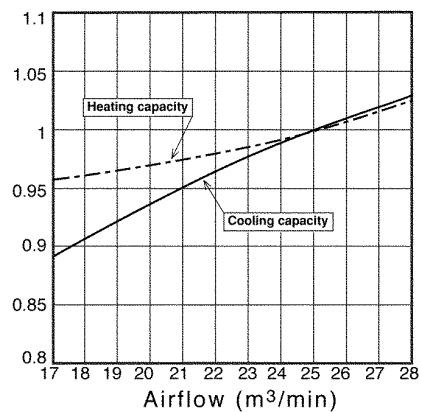

PEAD-RP100GA

Fan performance <220V>

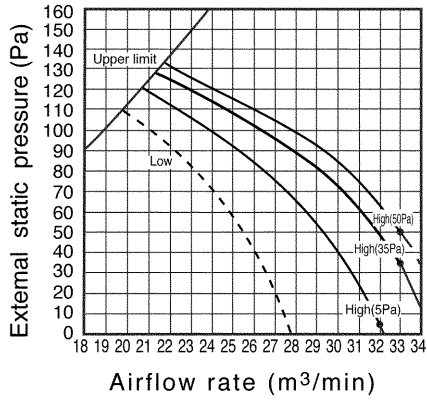

Fan performance <230V>

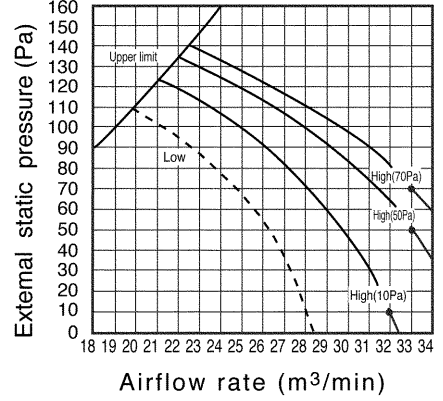

Fan performance <240V>

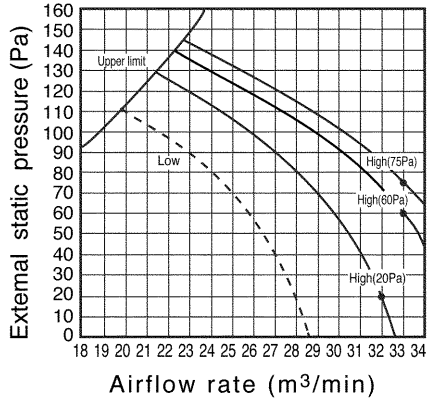

Corrected air flow

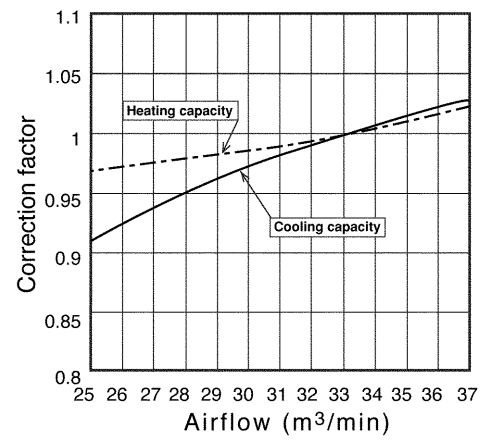

9-4. PEA-RP-GA Fan Performance Curve

PEA-RP200GA
Fan Performance Curve 50Hz

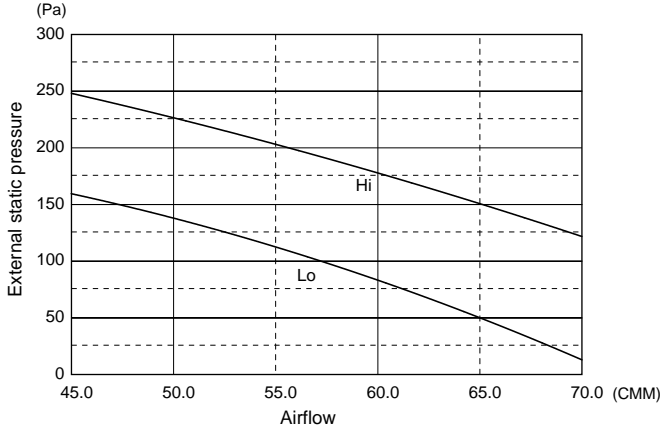

PEA-RP250GA
Fan Performance Curve 50Hz

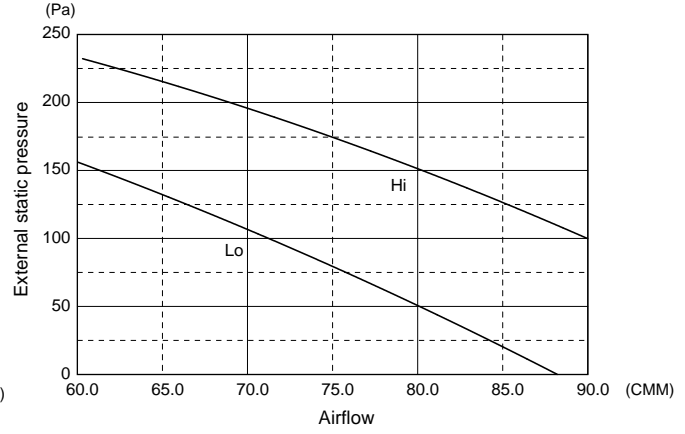

PEA-RP400GA
Fan Performance Curve 50Hz

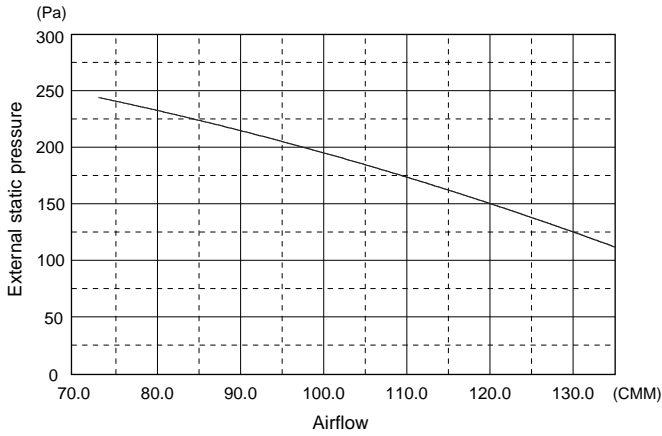

PEA-RP500GA
Fan Performance Curve 50Hz

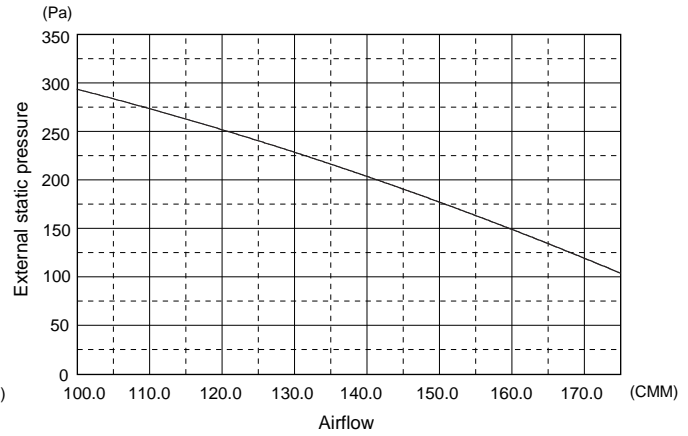

10-1. INDOOR UNIT

PLA-RP50BA

NOTCH	SPL(dB)	LINE
High	32	○—○
Medium1	31	●—●
Medium2	29	△—△
Low	28	◀—▶

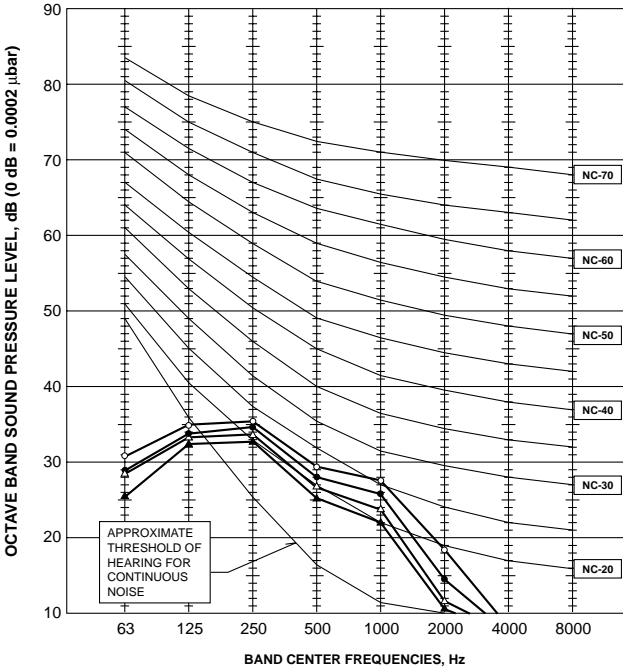

PLA-RP60BA

NOTCH	SPL(dB)	LINE
High	32	○—○
Medium1	31	●—●
Medium2	29	△—△
Low	28	◀—▶

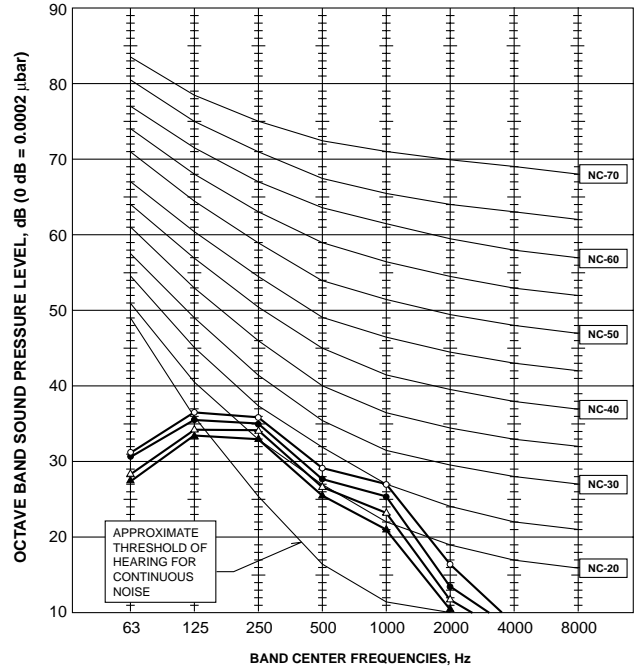

PLA-RP71BA

NOTCH	SPL(dB)	LINE
High	34	○—○
Medium1	32	●—●
Medium2	30	△—△
Low	28	◀—▶

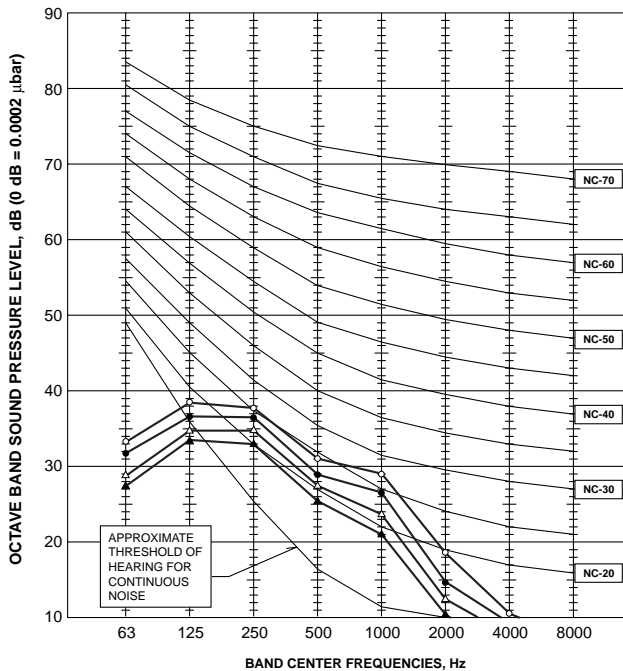

PLA-RP100BA

NOTCH	SPL(dB)	LINE
High	40	○—○
Medium1	37	●—●
Medium2	34	△—△
Low	32	◀—▶

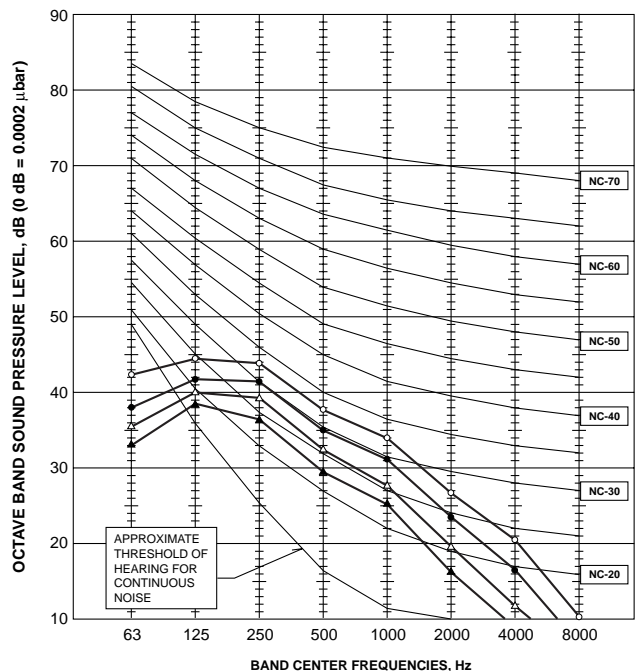

PLA-RP125BA

NOTCH	SPL(dB)	LINE
High	41	○—○
Medium1	39	●—●
Medium2	36	△—△
Low	34	▲—▲

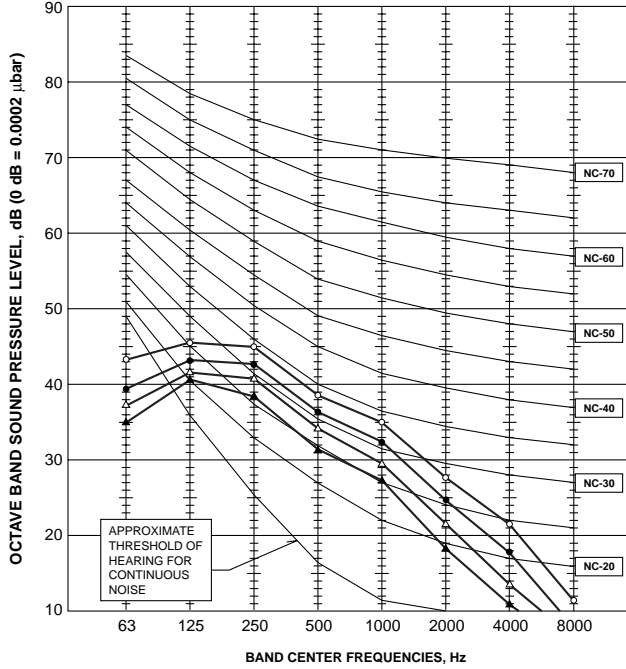

PLA-RP140BA

NOTCH	SPL(dB)	LINE
High	44	○—○
Medium1	42	●—●
Medium2	39	△—△
Low	36	▲—▲

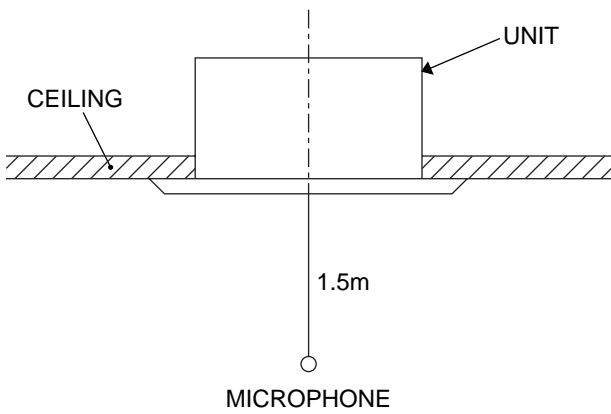
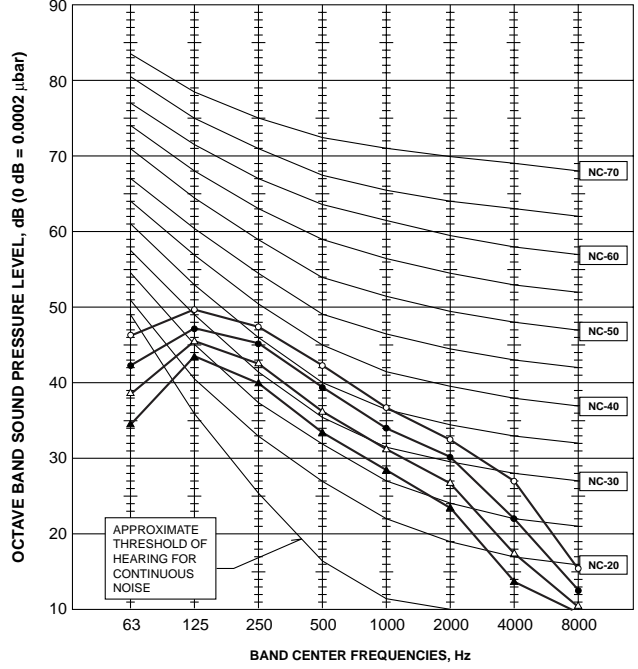

Ceiling concealed

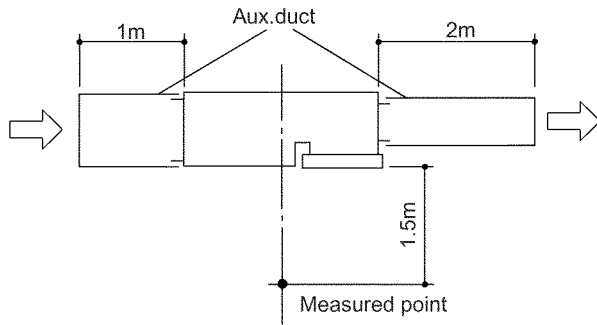

Noise level at anechoic room (Low-High)

Unit : dB(A)

Model	External static pressure		
	30Pa	70Pa	130Pa
PEAD-RP50EA	36-40	38-44	-
PEAD-RP60EA	37-41	39-46	-
PEAD-RP71EA	-	37-41	40-45 *
PEAD-RP100EA2	-	44-50	46-52 *
PEAD-RP125EA	-	44-50	46-52 *
PEAD-RP140EA	-	46-51	47-53 *

* Optional motor

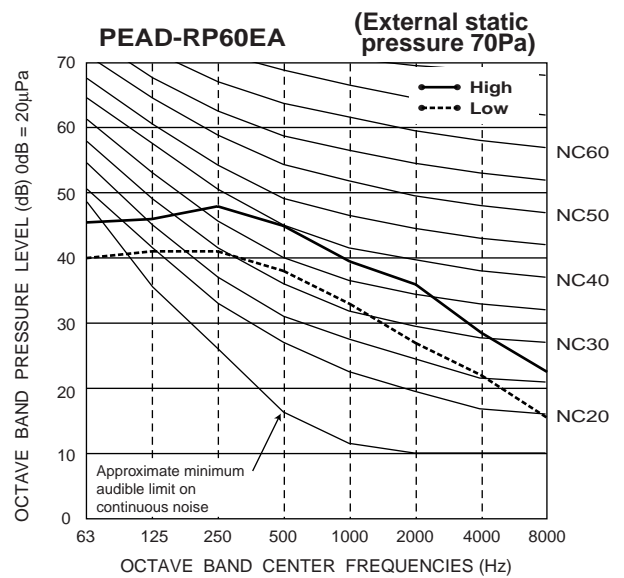
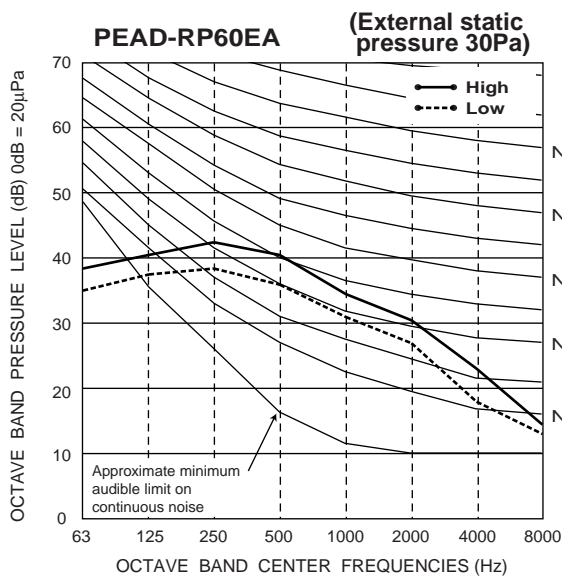
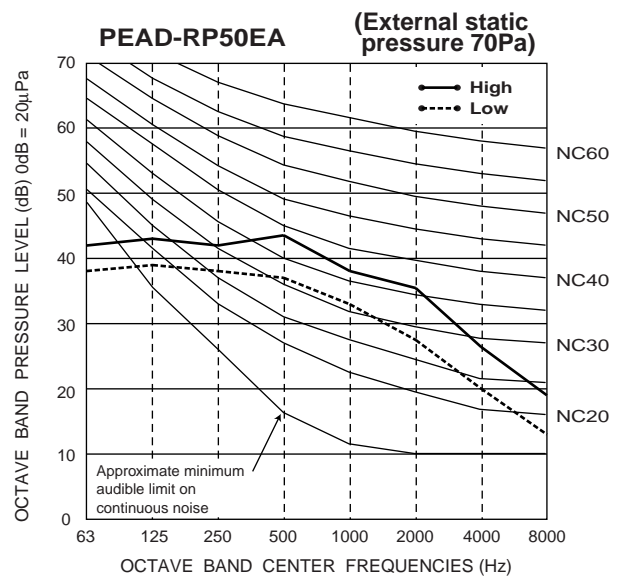
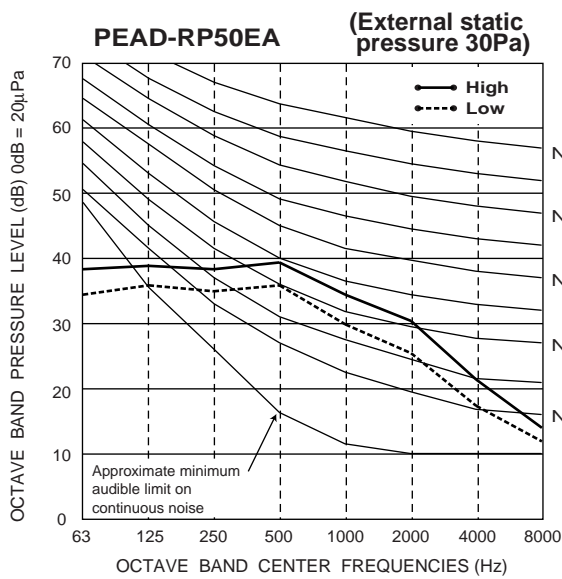

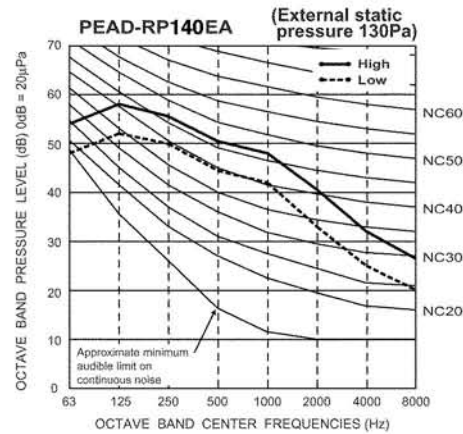
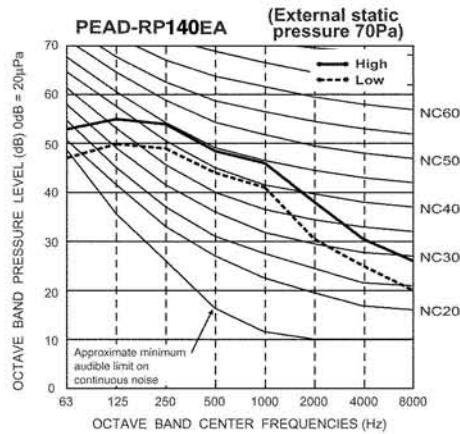
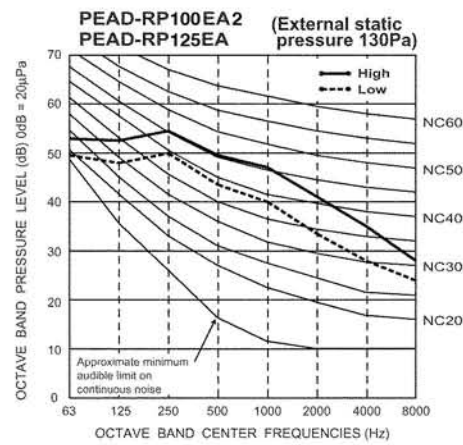
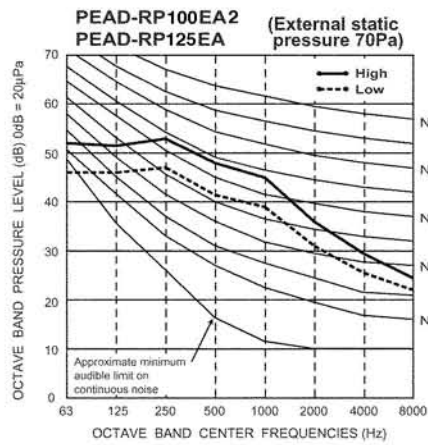
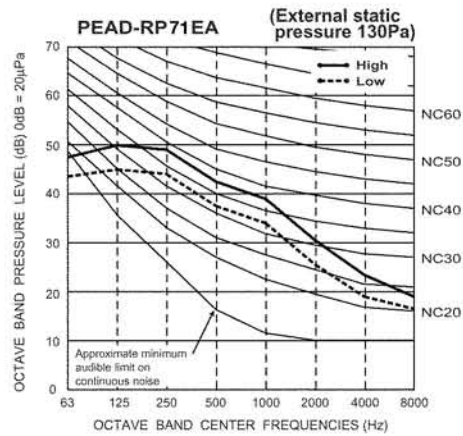
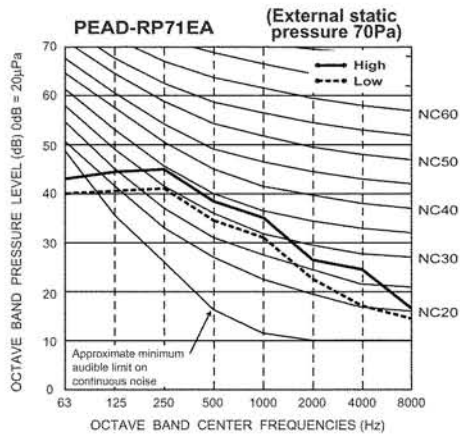

Sound Data

PEA-RP200, 250 : Upper High/Lower Low

Model	SPL dB(A)	OCTAVE BAND FREQ.Hz							
		63Hz	125Hz	250Hz	500Hz	1000Hz	2000Hz	4000Hz	8000Hz
PEA-RP200GA	51	55	54	51	49	47	43	33	27
	48	50	50	47	46	44	40	29	21
PEA-RP250GA	52	56	55	52	50	48	44	34	28
	49	51	51	48	47	45	41	30	22
PEA-RP400GA	52	53	51	52	50	46	44	39	30
PEA-RP500GA	53	55	54	51	50	48	44	40	31

Position measurement

Indoor unit

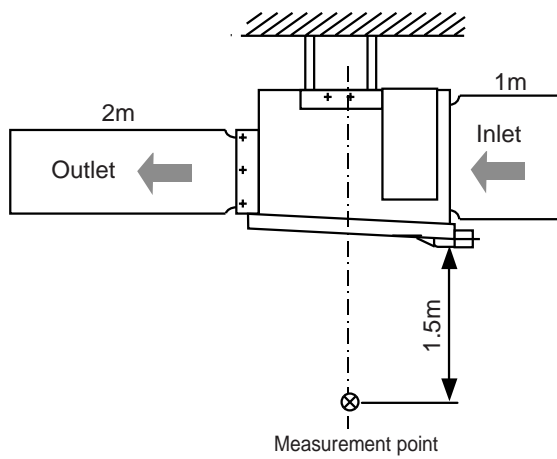

PKA-RP50GAL

NOTCH	SPL(dB)	LINE
High	43	○—○
Medium1	41	△—△
Medium2	38	●—●
Low	36	▲—▲

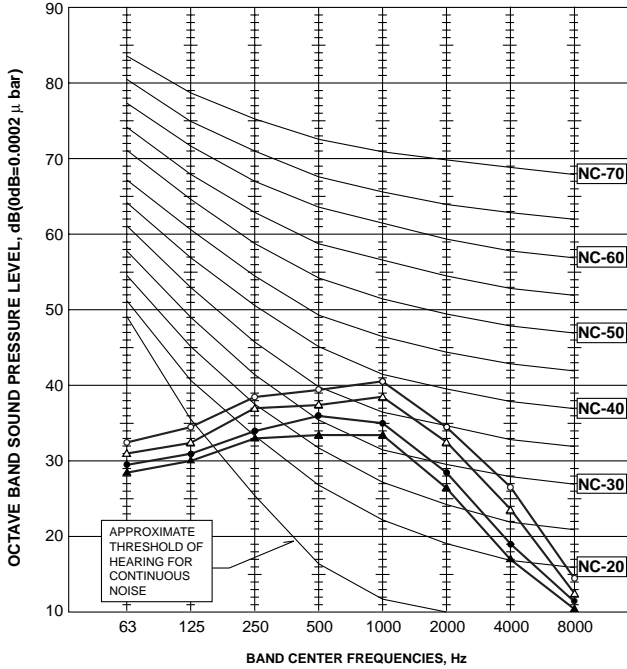

PKA-RP50FAL2 PKA-RP60FAL PKA-RP71FAL

NOTCH	SPL(dB)	LINE
High	45	○—○
Low	39	●—●

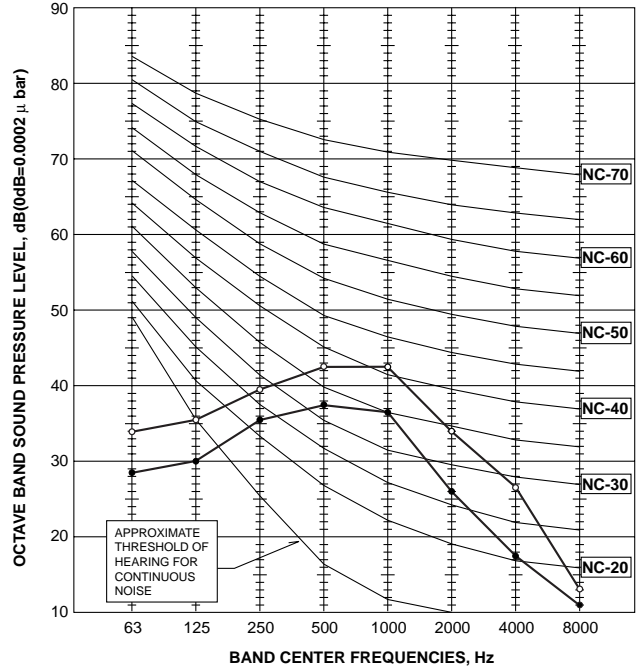

PKA-RP100FAL

NOTCH	SPL(dB)	LINE
High	46	○—○
Low	41	●—●

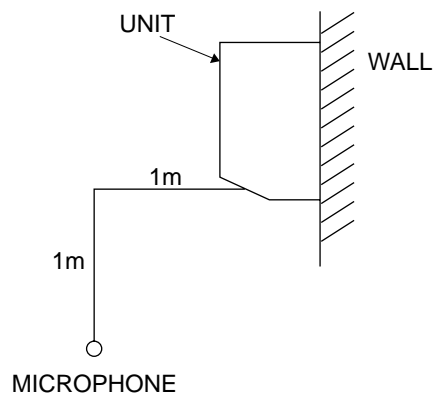
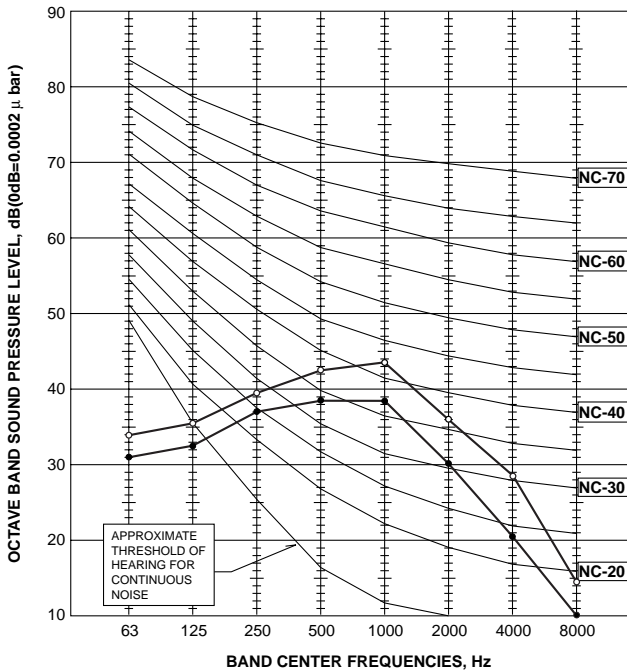

PCA-RP50GA

NOTCH	SPL(dB)	LINE
High	42	○—○
Medium1	40	△—△
Medium2	38	●—●
Low	37	▲—▲

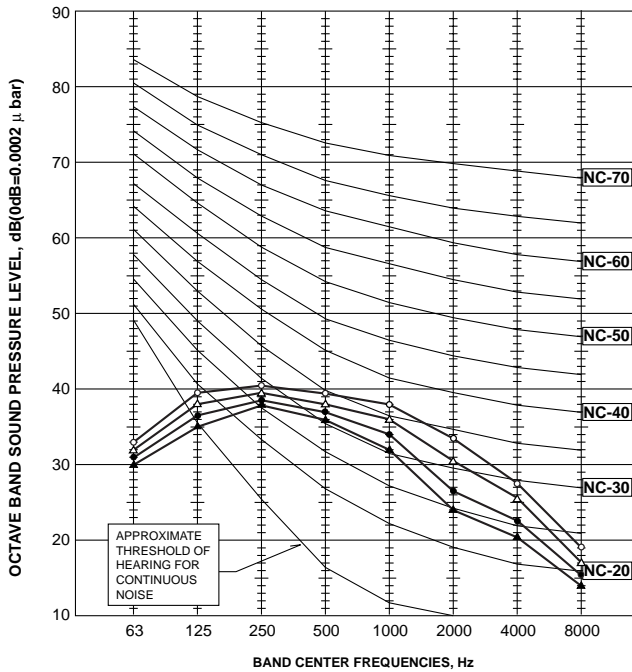

PCA-RP50GA2 PCA-RP60GA PCA-RP71GA

NOTCH	SPL(dB)	LINE
High	43	○—○
Medium1	41	△—△
Medium2	39	●—●
Low	37	▲—▲

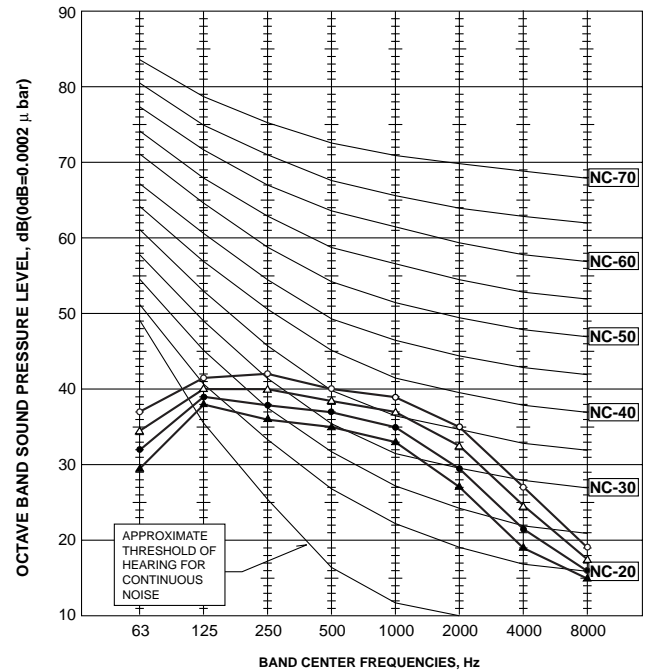

PCA-RP100GA

NOTCH	SPL(dB)	LINE
High	45	○—○
Medium1	43	△—△
Medium2	41	●—●
Low	40	▲—▲

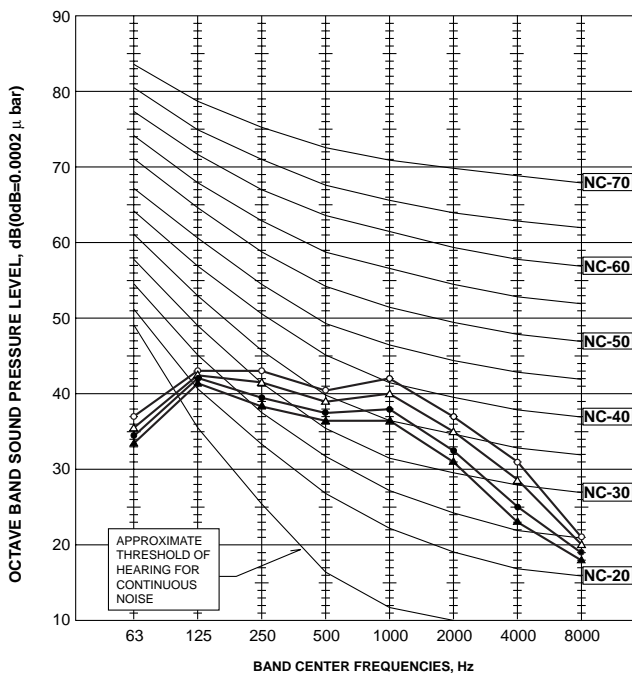

PCA-RP125GA

NOTCH	SPL(dB)	LINE
High	46	○—○
Medium1	45	△—△
Medium2	43	●—●
Low	41	▲—▲

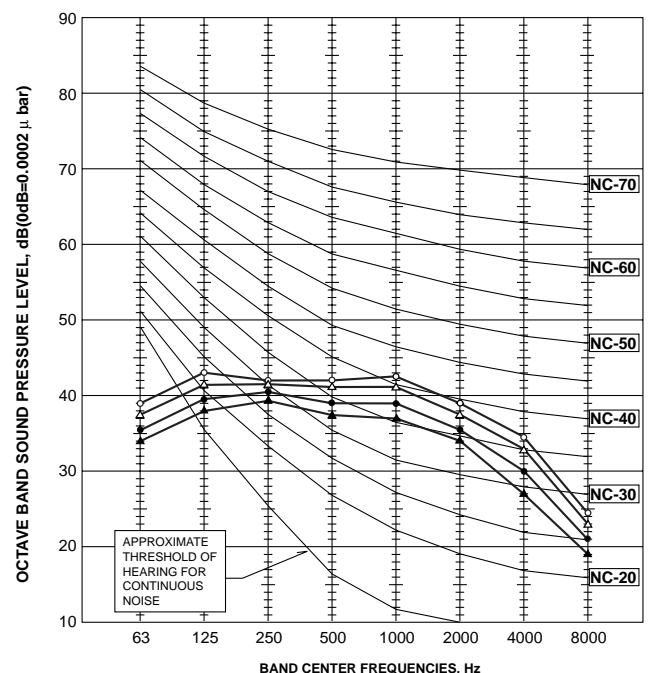

PCA-RP140GA

NOTCH	SPL(dB)	LINE
High	48	○—○
Medium1	46	△—△
Medium2	44	●—●
Low	42	▲—▲

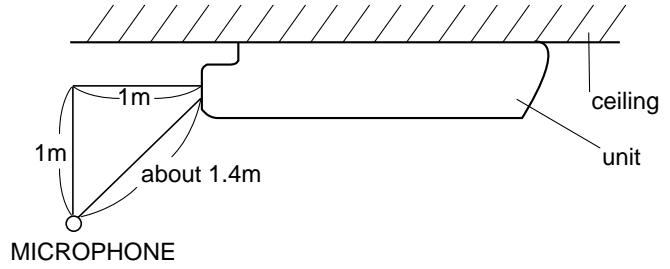
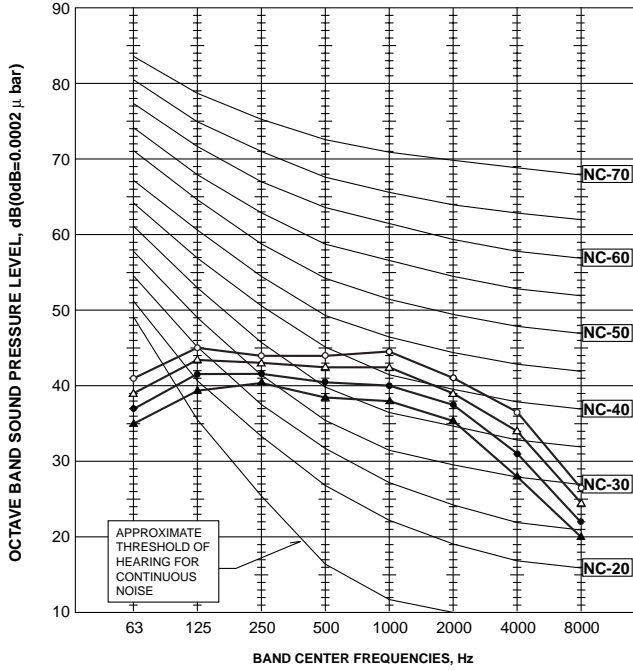

PCA-RP71HA

NOTCH	SPL(dB)	LINE
High	38	○—○
Low	34	●—●

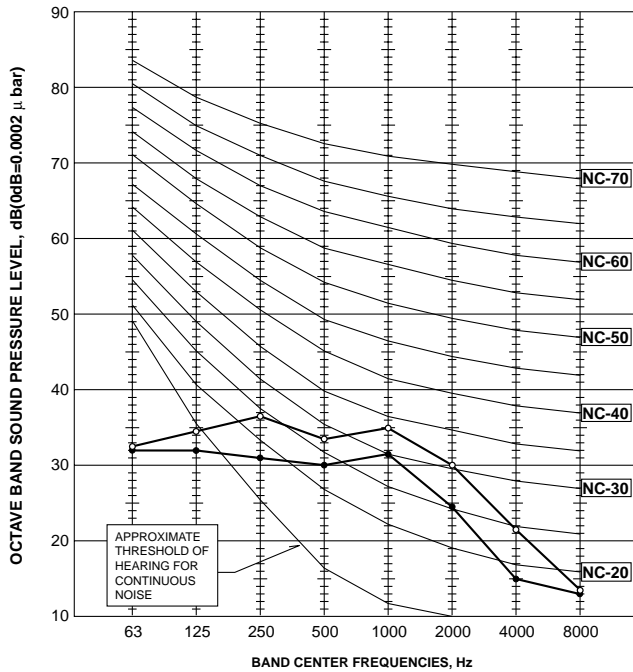

PCA-RP125HA

NOTCH	SPL(dB)	LINE
High	50	○—○
Low	44	●—●

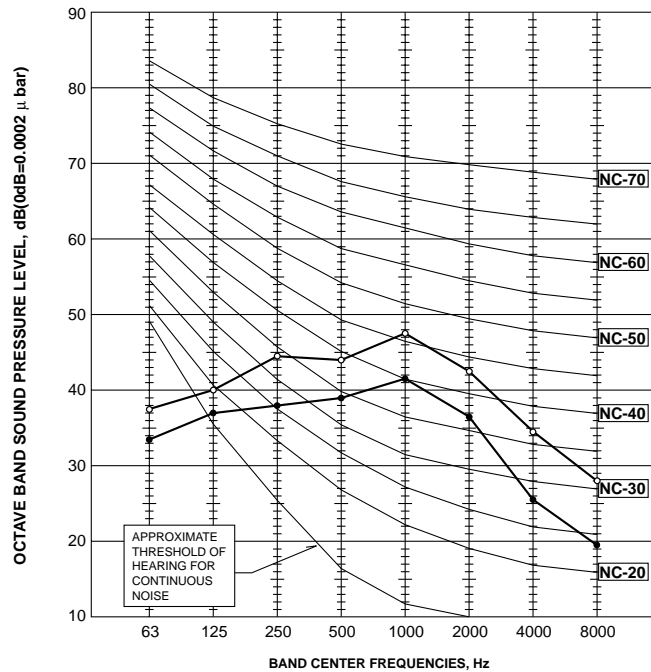

PSA-RP71GA

NOTCH	SPL(dB)	LINE
High	45	○—○
Low	40	●—●

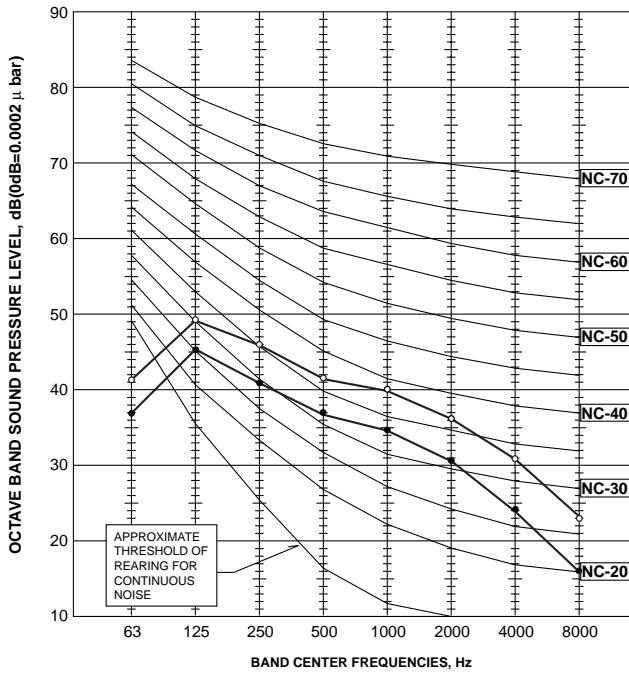

PSA-RP100GA

NOTCH	SPL(dB)	LINE
High	49	○—○
Low	44	●—●

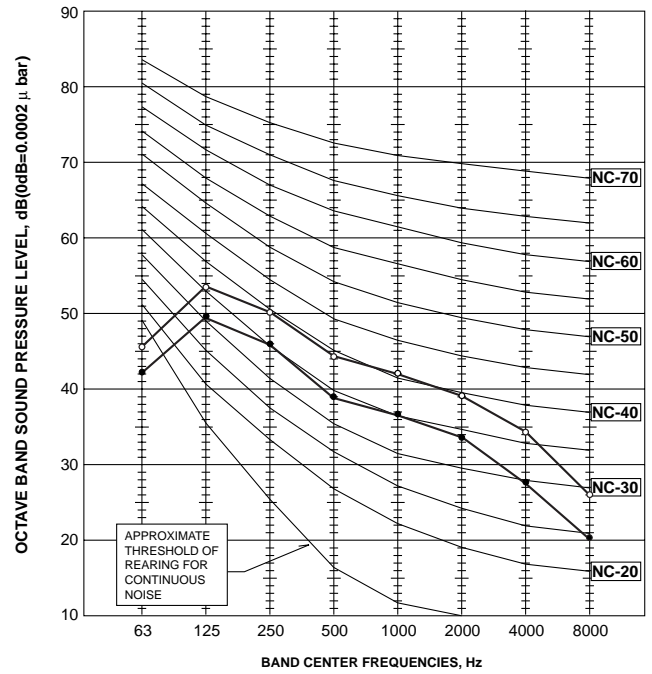

PSA-RP125GA

NOTCH	SPL(dB)	LINE
High	51	○—○
Low	46	●—●

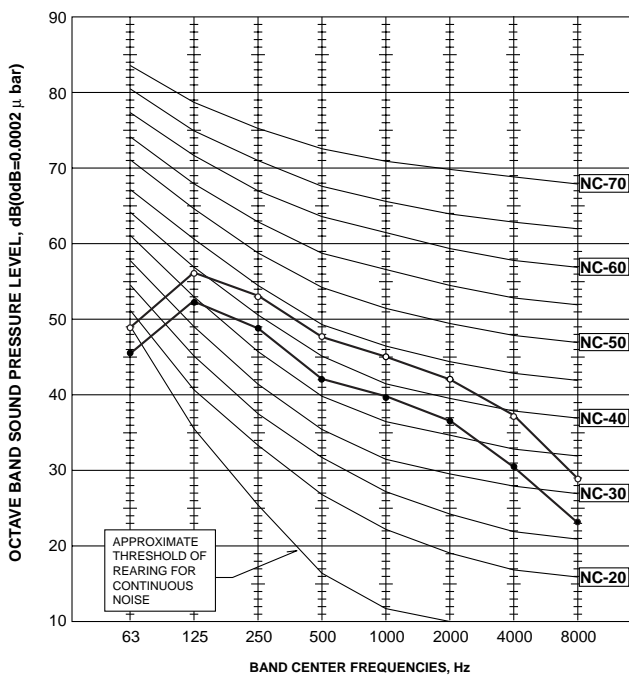

PSA-RP140GA

NOTCH	SPL(dB)	LINE
High	52	○—○
Low	47	●—●

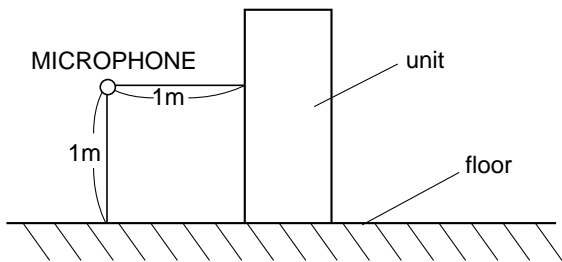
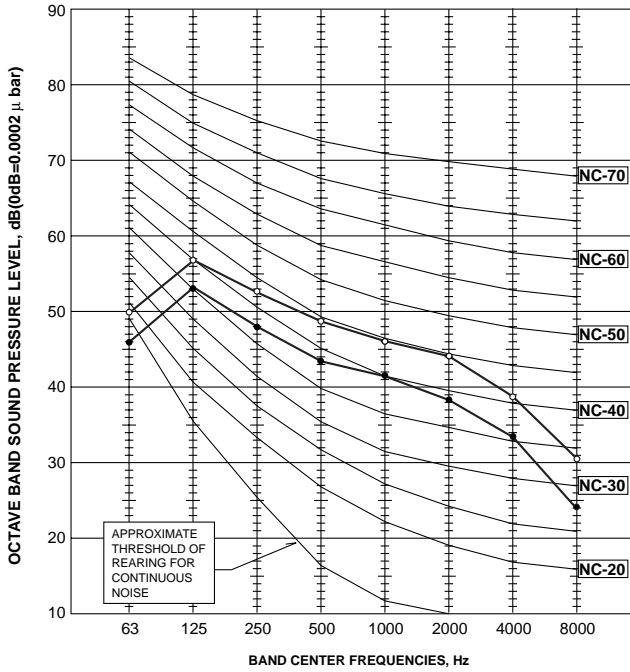

10-2. OUTDOOR UNIT

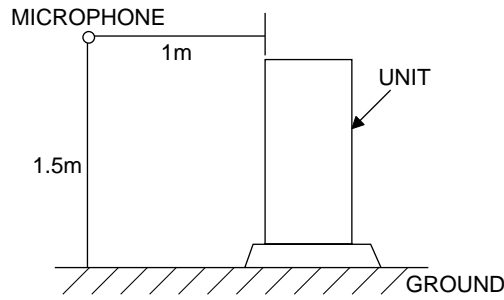

PUHZ-P100VHA2

MODE	SPL(dB)	LINE
COOLING	50	○—○
HEATING	54	●—●

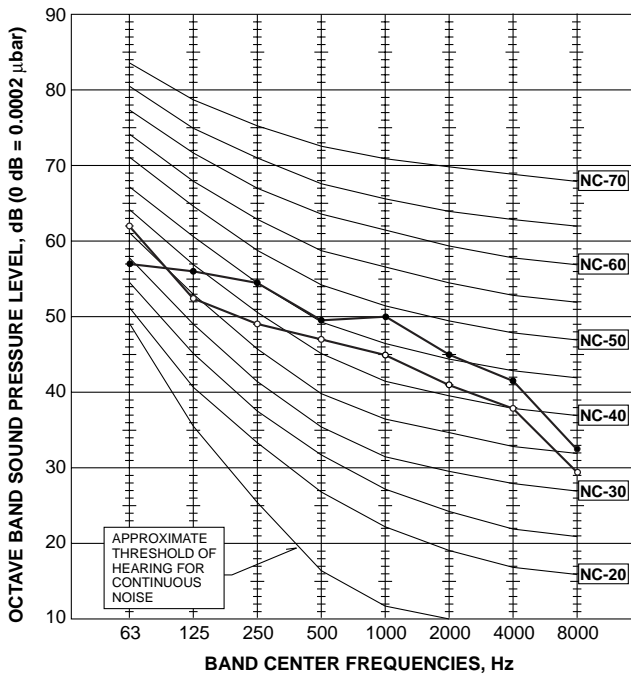

PUHZ-P125VHA2

MODE	SPL(dB)	LINE
COOLING	51	○—○
HEATING	55	●—●

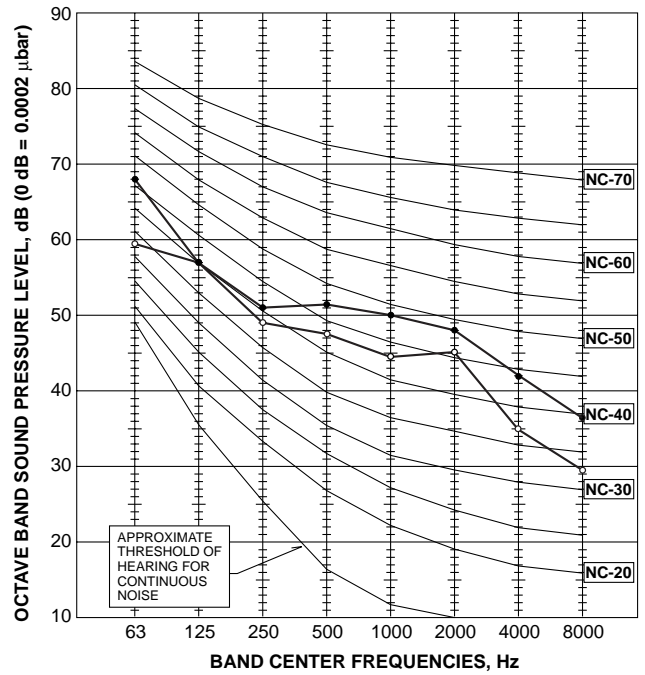

PUHZ-P140VHA2

MODE	SPL(dB)	LINE
COOLING	52	○—○
HEATING	56	●—●

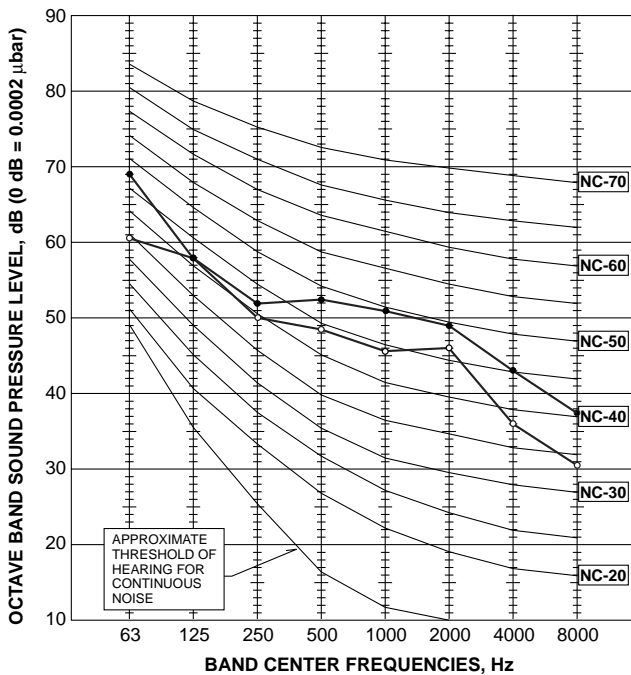

PUHZ-P200YHA PUHZ-P250YHA

MODE	SPL(dB)	LINE
COOLING	59	○—○
HEATING	59	●—●

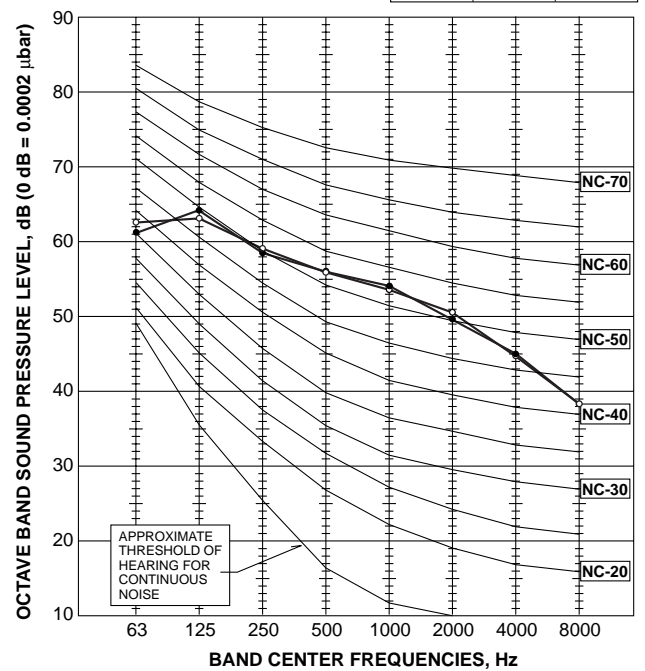

11-1. INDOOR UNIT

Part Name		Model Name	Applicable model
Remote sensor		PAC-SE41TS-E	All models
Remote operation adapter		PAC-SF40RM-E	
Multiple remote controller adapter		PAC-SA88HA-E (1pc.)	
		PAC-725AD (10pcs.)	
Remote on/off adapter		PAC-SE55RA-E	
Power supply terminal kit	L/N/Earth	PAC-SG96HR-E	PEAD-RP-EA(2), PCA-RP-GA(2) PKA-RP-GAL/FAL(2) PSA-RP-GA
		PAC-SH52HR-E	PLA-RP-BA
	L/N	PAC-SG97HR-E	PCA-RP-HA PEAD-RP-GA
Decoration panel		PLP-6BA	PLA-RP-BA
Decoration panel with Wireless remote controller		PLP-6BALM	
Decoration panel with Wired remote controller		PLP-6BAMD	
Automatic filter elevation panel		PLP-6BAJ	
i-see sensor corner panel		PAC-SA1ME-E	
Wireless signal receiver		PAR-SA9FA-E	
Space panel		PAC-SH48AS-E	
Multi-function casement		PAC-SH53TM-E	
Flange for fresh air intake		PAC-SH65OF-E	
High-efficiency filter element (PAC-SH53TM-E is needed.)		PAC-SH59KF-E	
Air outlet shutter plate		PAC-SH51SP-E	
Wireless remote controller + Wireless Adapter		PAR-SL99B-E	PCA-RP-GA(2)
Drain lift up mechanism		PAC-SH20DM-E	PCA-RP50,60GA(2)
		PAC-SH21DM-E	PCA-RP71GA
		PAC-SH22DM-E	PCA-RP100,125,140GA
High-efficiency filter		PAC-SE80KF-E	PCA-RP50GA
		PAC-SE81KF-E	PCA-RP60,71,100GA,50GA2
		PAC-SE82KF-E	PCA-RP125,140GA
Duct flange for fresh air		PAC-SF28OF-E	PCA-RP-HA
Oil mist filter element (12pcs)		PAC-SG38KF-E	
Decoration cover (Front + Suspending bracket cover)		PAC-SF81KC-E	PCA-RP71HA
		PAC-SF82KC-E	PCA-RP125HA
Wired remote controller (with terminal bed)		PAR-21MAAT-E	PKA-RP-GAL
			PKA-RP-FAL(2)
Drain lift up mechanism		PAC-SE90DM-E	PKA-RP-FAL(2)
Motor (for high external static pressure)		PAC-SK003MT-F	PEAD-RP125,140EA
			PEAD-RP100EA2
Drain lift up mechanism		PAC-KE03DM-F	PEAD-RP-EA,EA2
Insulation kit		PAC-SK010DK	PEAD-RP-GA

11-2. OUTDOOR UNIT

Part Name		Model Name	Applicable model
M-NET adapter		PAC-SF80MA-E	PUHZ-P100-250
A-control service tool		PAC-SK52ST	PUHZ-P100-250
Drain socket		PAC-SG61DS-E	PUHZ-P100-250
Air outlet guide (P125-250 need 2 pieces.)		PAC-SG59SG-E	PUHZ-P100-250
Air protect guide (P125-250 need 2 pieces.)		PAC-SG57AG-E	PUHZ-P100-250
Drain pan		PAC-SG64DP-E	PUHZ-P100-250
Filter dryer	(ϕ 9.52)	PAC-SG82DR-E	PUHZ-P100-250
	(ϕ 12.7)	PAC-SG85DR-E	PUHZ-P250
Distribution pipe	(Twin)	MSDD-50SR-E	PUHZ-P100-140
		MSDD-50WR-E	PUHZ-P200, 250
	(Triple)	MSDT-111R-E	PUHZ-P140-250
	(Quadruple)	MSDF-1111R-E	PUHZ-P200, 250
Joint pipe (Unit → Extension pipe)	(ϕ 15.88 → ϕ 19.05)	PAC-SG75RJ-E	PUHZ-P100-140

Mr. SLIM™

 **mitsubishi electric corporation**

HEAD OFFICE : TOKYO BLDG., 2-7-3, MARUNOUCHI, CHIYODA-KU, TOKYO 100-8310, JAPAN