



# SEZ-KD50VA

Inverter Heat Pump

R410A Ceiling Concealed Ducted System

Designed for homes, offices, restaurants or shops, the SEZ series operates at low noise levels and is virtually invisible when installed within a suspended ceiling. Its low unit height and lightweight design also helps to make installation easier and more convenient.



Pictures not to scale

## Product Details

### SEZ-KD50VA Indoor Unit

Capacity (kW):	
Heating (Nominal) (Low - High)	6.00 (1.10 - 7.20)
Cooling (Nominal) (Low - High)	5.00 (1.10 - 5.60)
Heating (UK) (Low - High)	5.00 (0.90 - 6.00)
Cooling (UK) (Low - High)	4.95 (1.10 - 5.55)
SHF R410A (Nominal)	0.76
Width - mm	990
Depth - mm	700
Height - mm	200
Weight - kg	23
Airflow (m <sup>3</sup> /min) - Lo-Mi-Hi	10-12.5-15
Noise (dBA) - Lo-Mi-Hi	30-34-37
Pipe Size Gas mm (in)	12.7 (1/2)
Pipe Size Liquid mm (in)	6.35 (1/4)
Electrical Supply	Fed by Outdoor
Phase	Single
Fuse Rating (BS88) - HRC (A)	6
Interconnecting Cable No. Cores	4
Remote Controller Ref	PAR-21MAA

### SUZ-KA50VA Outdoor Unit

Width - mm	840
Depth - mm	330
Height - mm	850
Weight - kg	53
Noise (dBA) (Heating /Cooling) - Lo-Hi	53-55 /51-53
Electrical Supply	220-240v, 50Hz
Fuse Rating (BS88) - HRC (A)	25
Mains Cable No. Cores	3
Max Pipe Length (m)	30
Max Height Difference (m)	30
Charge (kg) - 7m	1.6

## Dimensions

### SEZ-KD50VA

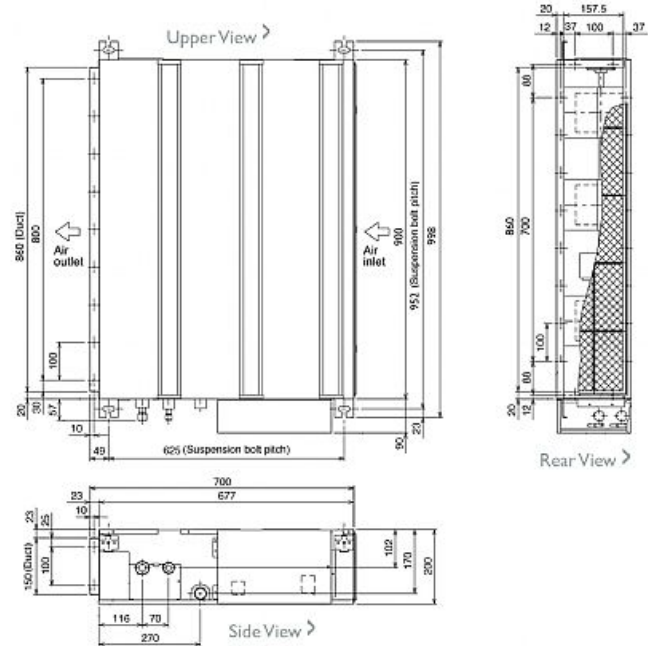

### SUZ-KA50VA

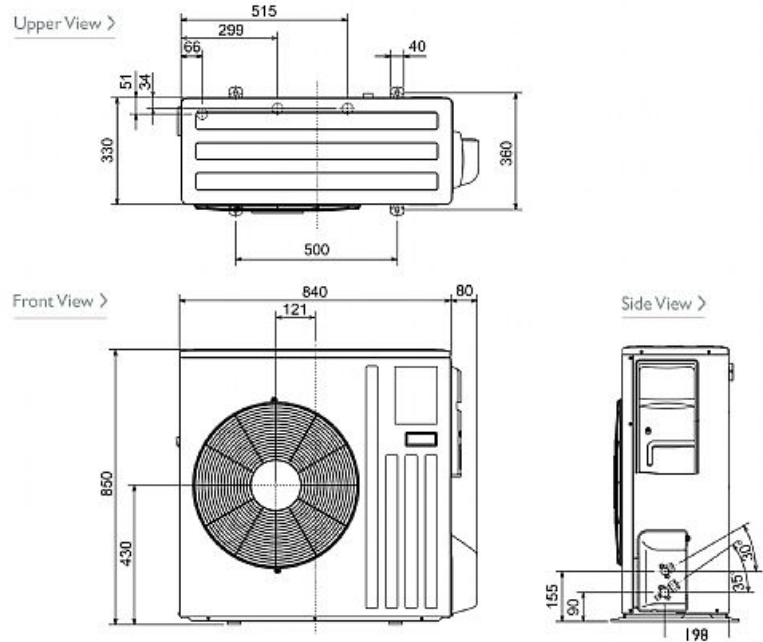

Telephone: 01707 282880

Email: [air.conditioning@meuk.mee.com](mailto:air.conditioning@meuk.mee.com) Website: <http://www.mitsubishielectric.co.uk/aircon>

Tel:  
Fax:



Mitsubishi Electric reserves the right to make any variation in technical specification to the equipment described, or to withdraw or replace products without prior notification or public announcement.