

# **SERVICE PARTS LIST FOR MITSUBISHI ELECTRIC PACKAGED AIR-CONDITIONERS**

**Series : PEAD-RP·JA.UK  
PEAD-RP·JAL.UK**

**Apr. 2009**

**BWE08240**

<b>INDEX</b>
<b>PEAD-RP35JA.UK</b>
<b>PEAD-RP50JA.UK</b>
<b>PEAD-RP60JA.UK</b>
<b>PEAD-RP71JA.UK</b>
<b>PEAD-RP100JA.UK</b>
<b>PEAD-RP125JA.UK</b>
<b>PEAD-RP140JA.UK</b>
<b>PEAD-RP35JAL.UK</b>
<b>PEAD-RP50JAL.UK</b>
<b>PEAD-RP60JAL.UK</b>
<b>PEAD-RP71JAL.UK</b>
<b>PEAD-RP100JAL.UK</b>
<b>PEAD-RP125JAL.UK</b>
<b>PEAD-RP140JAL.UK</b>

PEAD-RP35,RP50,RP60,RP71JA.UK  
PEAD-RP100,RP125,RP140JA.UK

EXTERNAL PARTS (1)

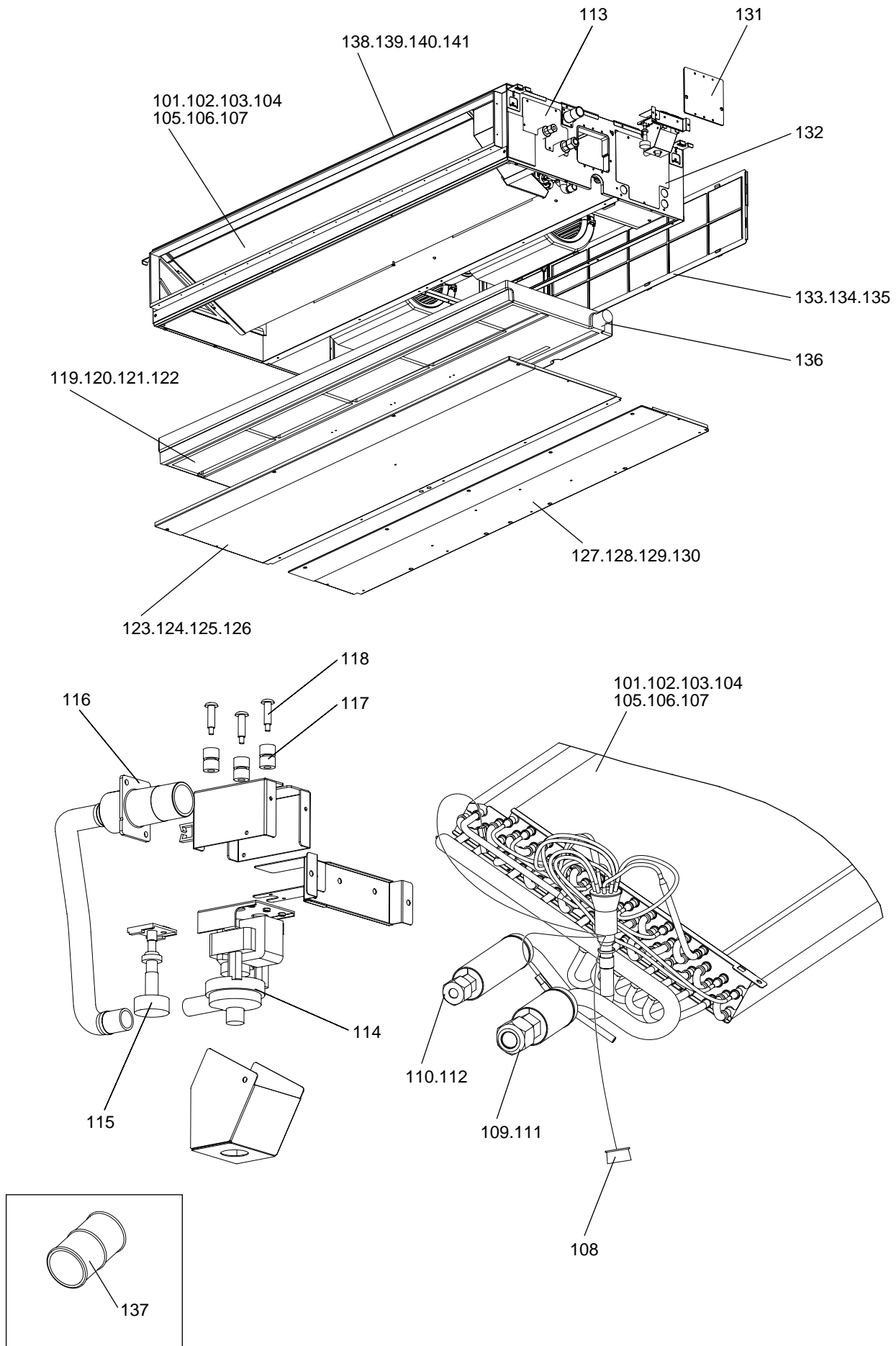

No.	Part No.	G : RoHS Apply Only W : RoHS Apply by Running Change		Spec.	PEAD-RP35JA.UK	PEAD-RP50JA.UK	PEAD-RP60JA.UK	PEAD-RP71JA.UK	PEAD-RP100JA.UK	PEAD-RP125JA.UK	Dwg. No.	Price	Revision History
		Part Name											
101	S70 E16 480	G	HEAT EXCHANGER		1						KB00A202B01		
102	S70 E13 480	G	HEAT EXCHANGER			1					KB00A203B01		
103	S70 E11 480	G	HEAT EXCHANGER				1				KB00A178B03		
104	S70 E18 480	G	HEAT EXCHANGER					1			KB00A178B01		
105	S70 E19 480	G	HEAT EXCHANGER						1		KB00A178B02		
106	S70 E12 480	G	HEAT EXCHANGER							1	KB00A179B04		
107	S70 E14 480	G	HEAT EXCHANGER								KB00A179B03		
108	S70 100 202	G	THERMISTOR		1	1	1	1	1	1	KB71B945M01		
109	S70 0B1 097	G	NUT FLARE 1/2F		1	1					BG12S008H01		
110	S70 E10 097	G	NUT FLARE 1/4		1	1					Z211A143H01		
111	S70 E09 097	G	NUT FLARE 5/8				1	1	1	1	BG12S826H01		
112	S70 E14 097	G	NUT FLARE 3/8				1	1	1	1	Z211A143H06		
113	S70 E11 065	G	COVER PIPE ASSY		1	1	1	1	1	1	KB00M203G02		
114	S70 E50 355	G	PUMP	PLD	1	1	1	1	1	1	KB56B953H03		
115	S70 E50 266	G	FLOAT SWITCH	#FS-0250	1	1	1	1	1	1	KB68B944H02		
116	S70 E50 527	G	SOCKET ASSY		1	1	1	1	1	1	KB00R308G04		
117	S70 E11 066	G	CUSHION		3	3	3	3	3	3	DB26F013L01		
118	S70 E40 673	G	SCREW SPECIAL M4X 6		3	3	3	3	3	3	Z003Z333H05		
119	S70 E20 529	G	DRAIN PAN ASSY P40		1	1					KB00R237G02		
120	S70 E30 529	G	DRAIN PAN ASSY P63				1	1			KB00R237G03		
121	S70 E40 529	G	DRAIN PAN ASSY P100						1	1	KB00R237G04		
122	S70 E50 529	G	DRAIN PAN ASSY P140								KB00R237G05		
123	S70 E03 669	G	PANEL UD1 ASSY P40		1	1					KB00R305G07		
124	S70 E05 669	G	PANEL UD1 ASSY P63				1	1			KB00R305G08		
125	S70 E07 669	G	PANEL UD1 ASSY P100						1	1	KB00R305G09		
126	S70 E09 669	G	PANEL UD1 ASSY P140								KB00R305G10		
127	S70 E04 669	G	PANEL UD2 ASSY P40		1	1					KB00R306G07		
128	S70 E06 669	G	PANEL UD2 ASSY P63				1	1			KB00R306G08		
129	S70 E08 669	G	PANEL UD2 ASSY P100						1	1	KB00R306G09		
130	S70 E10 669	G	PANEL UD2 ASSY P140								KB00R306G10		
131	S70 E12 067	G	COVER ASSY		1	1	1	1	1	1	KB00M197G02		
132	S70 E13 068	G	COVER BOX ASSY		1	1	1	1	1	1	KB00T337G02		
133	S70 E55 500	G	FILTER 550				2	2			KB35B880G01		
134	S70 E70 500	G	FILTER 700						2	2	KB35B882G01		
135	S70 E90 500	G	FILTER 900		1	1					KB35B881G01		
136	S70 E16 524	G	PLUG	RUBBER	1	1	1	1	1	1	KB26H049H01		
137	S70 29H 523	G	SOCKET		1	1	1	1	1	1	BB25D449H01		
138	S70 E20 642	G	PANEL TOP ASSY P40		1	1					KB00R292G07		
139	S70 E30 642	G	PANEL TOP ASSY P63				1	1			KB00R292G08		
140	S70 E40 642	G	PANEL TOP ASSY P100						1	1	KB00R292G09		
141	S70 E50 642	G	PANEL TOP ASSY P140								KB00R292G10		

No.	Part No.	G : RoHS Apply Only W : RoHS Apply by Running Change		Spec.	PEAD-RP140JA.UK					Dwg. No.	Price	Revision History
			Part Name									
101	S70 E16 480	G	HEAT EXCHANGER							KB00A202B01		
102	S70 E13 480	G	HEAT EXCHANGER							KB00A203B01		
103	S70 E11 480	G	HEAT EXCHANGER							KB00A178B03		
104	S70 E18 480	G	HEAT EXCHANGER							KB00A178B01		
105	S70 E19 480	G	HEAT EXCHANGER							KB00A178B02		
106	S70 E12 480	G	HEAT EXCHANGER							KB00A179B04		
107	S70 E14 480	G	HEAT EXCHANGER		1					KB00A179B03		
108	S70 100 202	G	THERMISTOR		1					KB71B945M01		
109	S70 0B1 097	G	NUT FLARE 1/2F							BG12S008H01		
110	S70 E10 097	G	NUT FLARE 1/4							Z211A143H01		
111	S70 E09 097	G	NUT FLARE 5/8		1					BG12S826H01		
112	S70 E14 097	G	NUT FLARE 3/8		1					Z211A143H06		
113	S70 E11 065	G	COVER PIPE ASSY		1					KB00M203G02		
114	S70 E50 355	G	PUMP	PLD	1					KB56B953H03		
115	S70 E50 266	G	FLOAT SWITCH	#FS-0250	1					KB68B944H02		
116	S70 E50 527	G	SOCKET ASSY		1					KB00R308G04		
117	S70 E11 066	G	CUSHION		3					DB26F013L01		
118	S70 E40 673	G	SCREW SPECIAL M4X 6		3					Z003Z333H05		
119	S70 E20 529	G	DRAIN PAN ASSY P40							KB00R237G02		
120	S70 E30 529	G	DRAIN PAN ASSY P63							KB00R237G03		
121	S70 E40 529	G	DRAIN PAN ASSY P100							KB00R237G04		
122	S70 E50 529	G	DRAIN PAN ASSY P140		1					KB00R237G05		
123	S70 E03 669	G	PANEL UD1 ASSY P40							KB00R305G07		
124	S70 E05 669	G	PANEL UD1 ASSY P63							KB00R305G08		
125	S70 E07 669	G	PANEL UD1 ASSY P100							KB00R305G09		
126	S70 E09 669	G	PANEL UD1 ASSY P140		1					KB00R305G10		
127	S70 E04 669	G	PANEL UD2 ASSY P40							KB00R306G07		
128	S70 E06 669	G	PANEL UD2 ASSY P63							KB00R306G08		
129	S70 E08 669	G	PANEL UD2 ASSY P100							KB00R306G09		
130	S70 E10 669	G	PANEL UD2 ASSY P140		1					KB00R306G10		
131	S70 E12 067	G	COVER ASSY		1					KB00M197G02		
132	S70 E13 068	G	COVER BOX ASSY		1					KB00T337G02		
133	S70 E55 500	G	FILTER 550							KB35B880G01		
134	S70 E70 500	G	FILTER 700		1					KB35B882G01		
135	S70 E90 500	G	FILTER 900		1					KB35B881G01		
136	S70 E16 524	G	PLUG	RUBBER	1					KB26H049H01		
137	S70 29H 523	G	SOCKET		1					BB25D449H01		
138	S70 E20 642	G	PANEL TOP ASSY P40							KB00R292G07		
139	S70 E30 642	G	PANEL TOP ASSY P63							KB00R292G08		
140	S70 E40 642	G	PANEL TOP ASSY P100							KB00R292G09		
141	S70 E50 642	G	PANEL TOP ASSY P140		1					KB00R292G10		

PEAD-RP35,RP50,RP60,RP71JAL.UK  
PEAD-RP100,RP125,RP140JAL.UK

EXTERNAL PARTS (2)

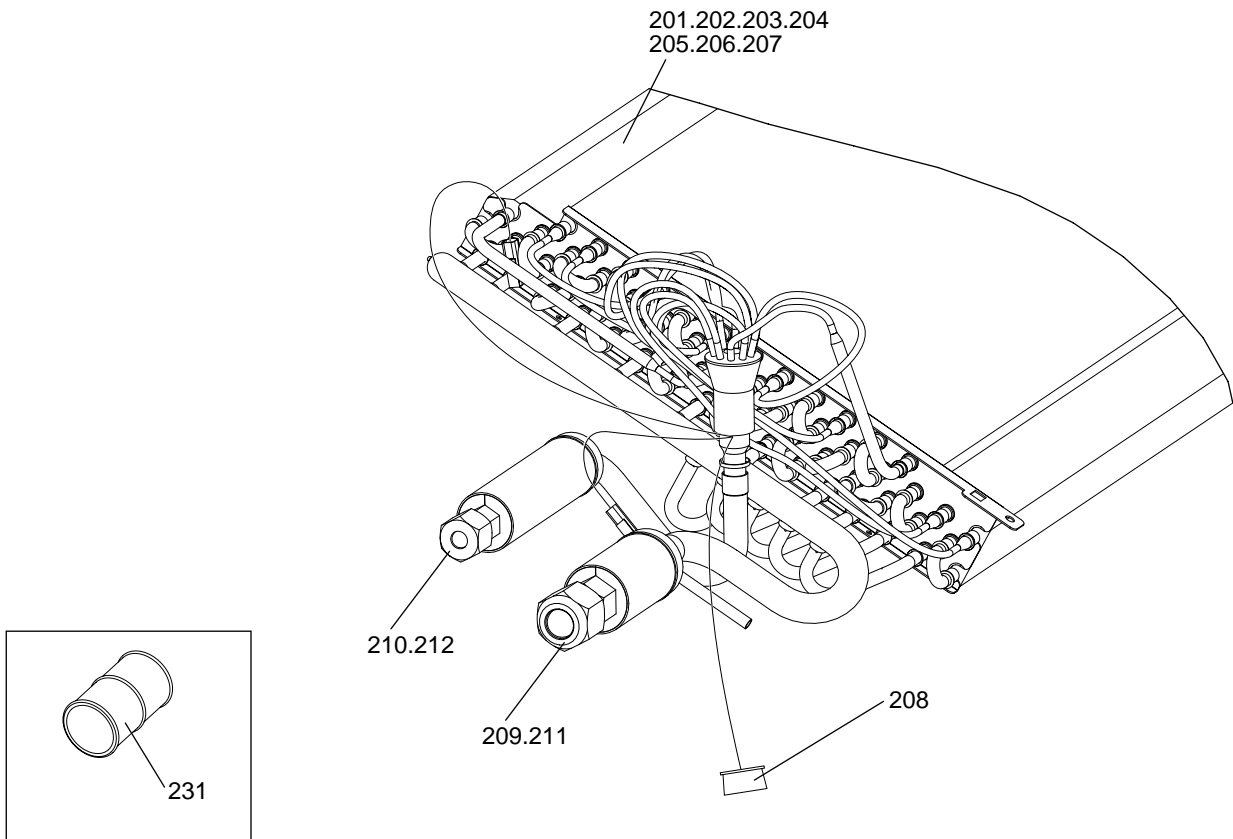
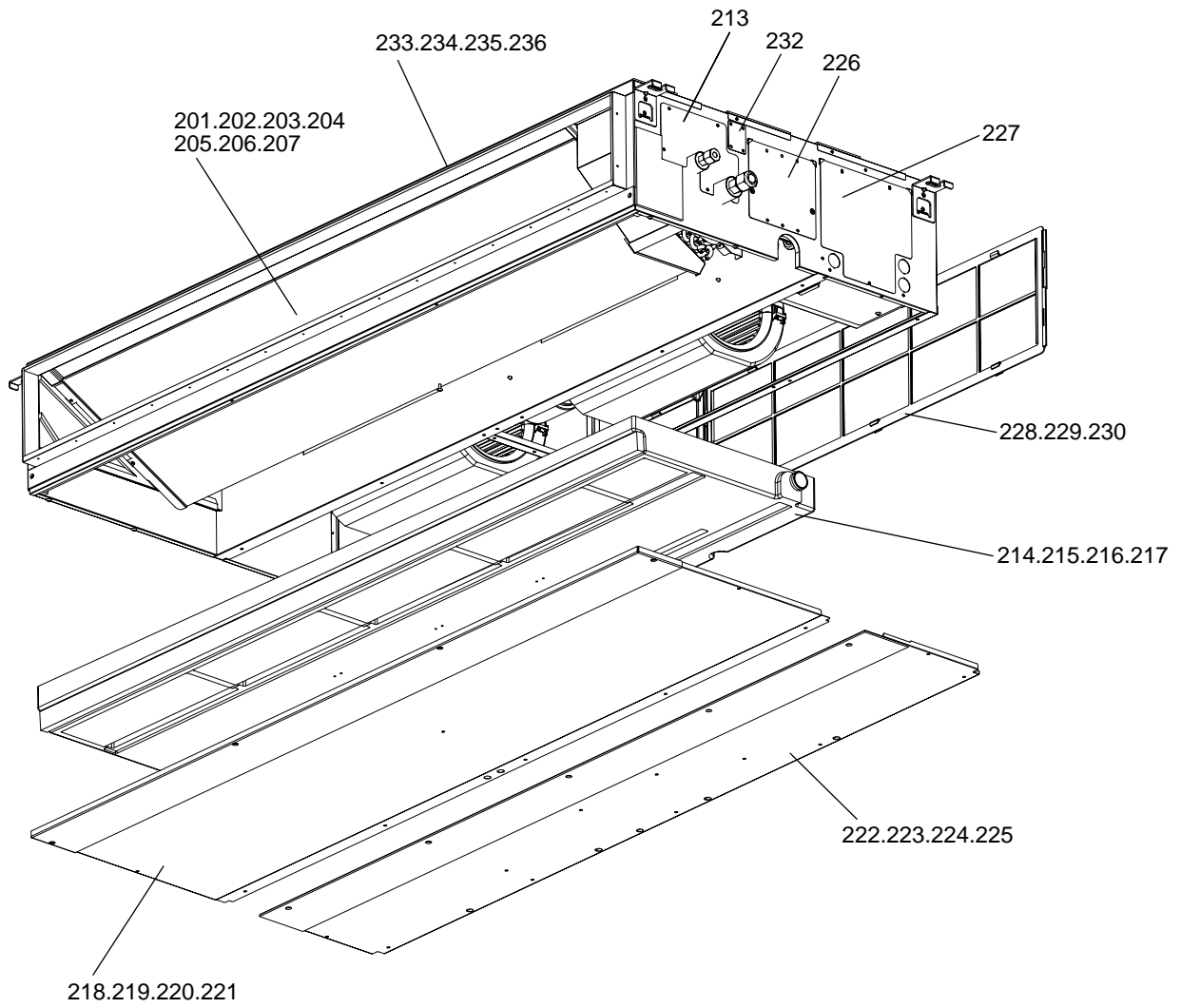



No.	Part No.	G : RoHS Apply Only W : RoHS Apply by Running Change		Spec.	PEAD-RP140JAL.UK					Dwg. No.	Price	Revision History
			Part Name									
201	S70 E16 480	G	HEAT EXCHANGER							KB00A202B01		
202	S70 E13 480	G	HEAT EXCHANGER							KB00A203B01		
203	S70 E11 480	G	HEAT EXCHANGER							KB00A178B03		
204	S70 E18 480	G	HEAT EXCHANGER							KB00A178B01		
205	S70 E19 480	G	HEAT EXCHANGER							KB00A178B02		
206	S70 E12 480	G	HEAT EXCHANGER							KB00A179B04		
207	S70 E14 480	G	HEAT EXCHANGER		1					KB00A179B03		
208	S70 100 202	G	THERMISTOR		1					KB71B945M01		
209	S70 0B1 097	G	NUT FLARE 1/2F							BG12S008H01		
210	S70 E10 097	G	NUT FLARE 1/4							Z211A143H01		
211	S70 E09 097	G	NUT FLARE 5/8		1					BG12S826H01		
212	S70 E14 097	G	NUT FLARE 3/8		1					Z211A143H06		
213	S70 E11 065	G	COVER PIPE ASSY		1					KB00M203G02		
214	S70 E20 529	G	DRAIN PAN ASSY P40							KB00R237G02		
215	S70 E30 529	G	DRAIN PAN ASSY P63							KB00R237G03		
216	S70 E40 529	G	DRAIN PAN ASSY P100							KB00R237G04		
217	S70 E50 529	G	DRAIN PAN ASSY P140		1					KB00R237G05		
218	S70 E03 669	G	PANEL UD1 ASSY P40							KB00R305G07		
219	S70 E05 669	G	PANEL UD1 ASSY P63							KB00R305G08		
220	S70 E07 669	G	PANEL UD1 ASSY P100							KB00R305G09		
221	S70 E09 669	G	PANEL UD1 ASSY P140		1					KB00R305G10		
222	S70 E04 669	G	PANEL UD2 ASSY P40							KB00R306G07		
223	S70 E06 669	G	PANEL UD2 ASSY P63							KB00R306G08		
224	S70 E08 669	G	PANEL UD2 ASSY P100							KB00R306G09		
225	S70 E10 669	G	PANEL UD2 ASSY P140		1					KB00R306G10		
226	S70 E12 067	G	COVER ASSY		1					KB00M197G02		
227	S70 E13 068	G	COVER BOX ASSY		1					KB00T337G02		
228	S70 E55 500	G	FILTER 550							KB35B880G01		
229	S70 E70 500	G	FILTER 700		1					KB35B882G01		
230	S70 E90 500	G	FILTER 900		1					KB35B881G01		
231	S70 29H 523	G	SOCKET		1					BB25D449H01		
232	S70 E30 522	G	COVER SOCKET ASSY		1					KB00M268G02		
233	S70 E20 642	G	PANEL TOP ASSY P40							KB00R292G07		
234	S70 E30 642	G	PANEL TOP ASSY P63							KB00R292G08		
235	S70 E40 642	G	PANEL TOP ASSY P100							KB00R292G09		
236	S70 E50 642	G	PANEL TOP ASSY P140		1					KB00R292G10		

PEAD-RP35,RP50,RP60,RP71JA.UK  
 PEAD-RP100,RP125JA.UK

BLOWER PARTS

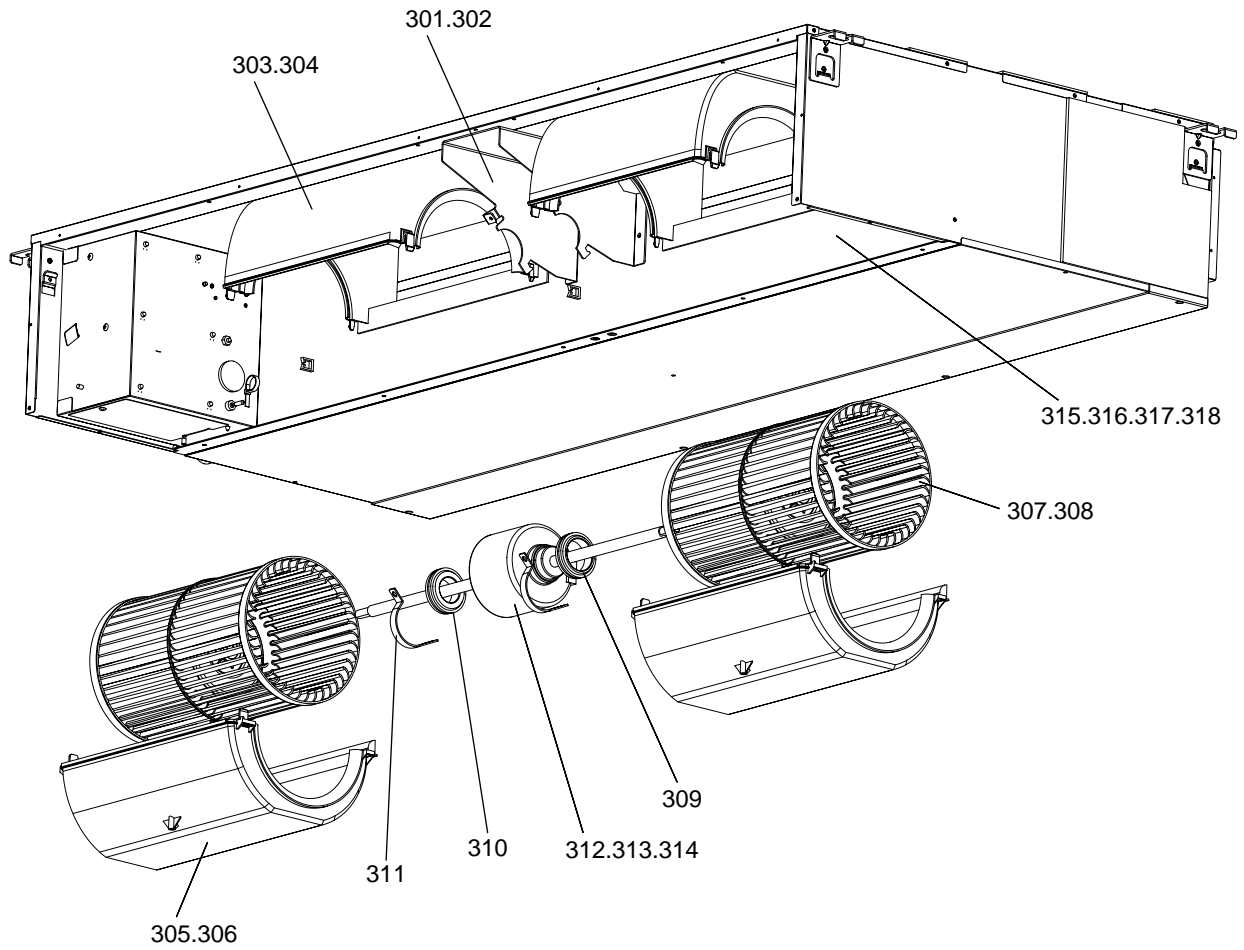

No.	Part No.	G : RoHS Apply Only W : RoHS Apply by Running Change		Spec.	PEAD-RP35JA.UK	PEAD-RP50JA.UK	PEAD-RP60JA.UK	PEAD-RP71JA.UK	PEAD-RP100JA.UK	PEAD-RP125JA.UK	Dwg. No.	Price	Revision History
			Part Name										
301	S70 E30 130	G	MOTOR BASE P20		1	1	1	1			KB02B861Z02		
302	S70 E40 130	G	MOTOR BASE P100						1	1	KB02B862Z02		
303	S70 E10 110	G	FAN CASE U				2	2			KB25A145G01		
304	S70 E30 110	G	FAN CASE U		1	1			2	2	KB25A144G01		
305	S70 E50 110	G	FAN CASE L				2	2			KB25A147G01		
306	S70 E40 110	G	FAN CASE L		1	1			2	2	KB25A146G01		
307	S70 E20 114	G	SIROCCO FAN 200 ASSY				2	2			KB00R101G01		
308	S70 E32 114	G	SIROCCO FAN 320 ASSY		1	1			2	2	KB00R102G01		
309	S70 L10 105	G	RUBBER MOUNT L		1	1	1	1			KB31D833H03		
310	S70 R20 105	G	RUBBER MOUNT R		1	1	1	1	2	2	KB31D833H04		
311	S70 E10 131	G	ATTACHMENT		2	2	2	2	2	2	W353715H01		
312	S70 E20 220	G	MOTOR P40		1	1					KB61B961H03		
313	S70 E30 220	G	MOTOR P63				1	1			KB61B962H03		
314	S70 E40 220	G	MOTOR P100						1	1	KB61B963H03		
315	S70 E20 677	G	FAN PLATE ASSY P40		1	1					KBT00T067G07		
316	S70 E30 677	G	FAN PLATE ASSY P63				1	1			KBT00T067G08		
317	S70 E40 677	G	FAN PLATE ASSY P100						1	1	KBT00T067G09		
318	S70 E50 677	G	FAN PLATE ASSY P140								KBT00T067G10		



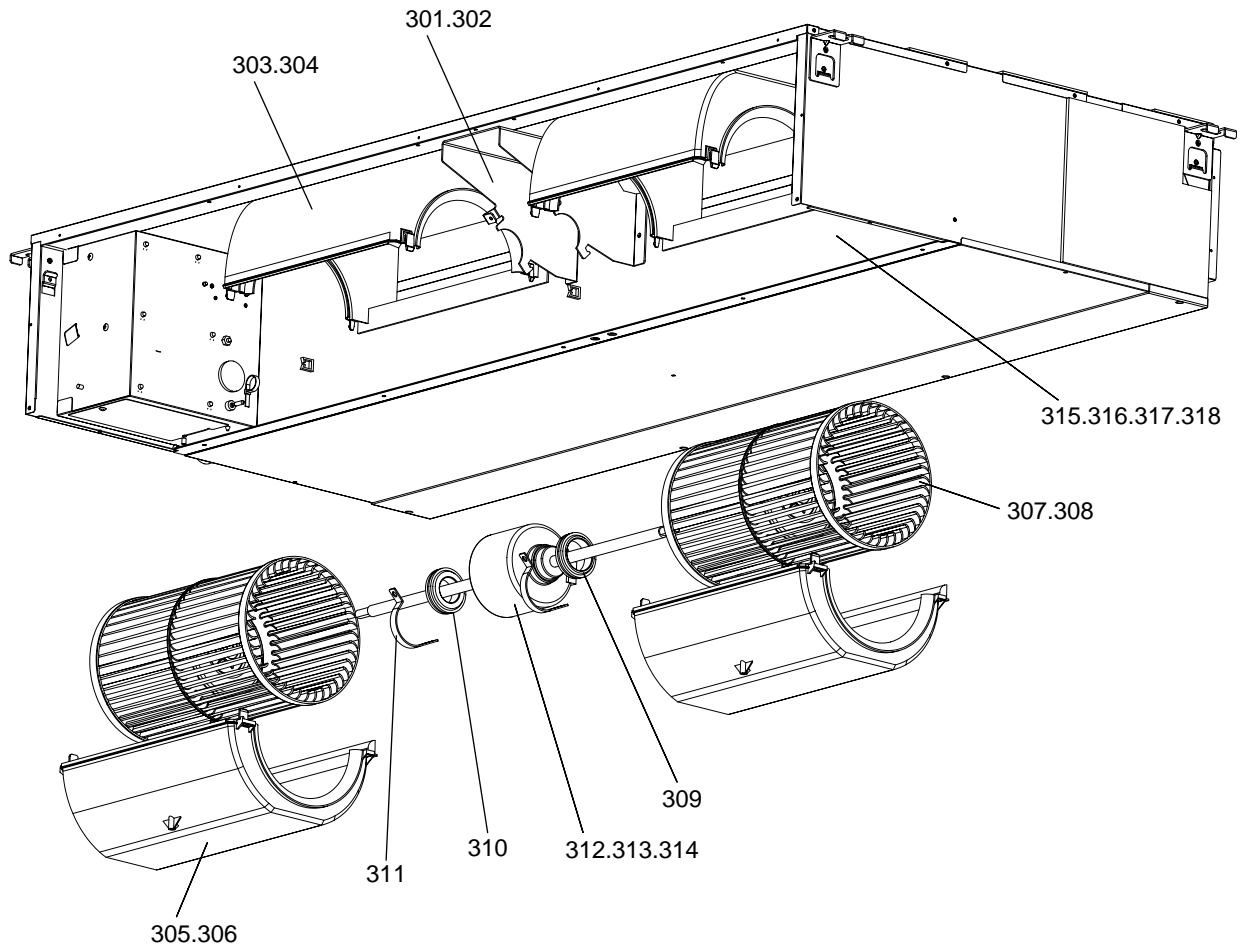

No.	Part No.	G : RoHS Apply Only W : RoHS Apply by Running Change		Spec.	PEAD-RP140JA.UK					Dwg. No.	Price	Revision History
			Part Name									
301	S70 E30 130	G	MOTOR BASE P20							KB02B861Z02		
302	S70 E40 130	G	MOTOR BASE P100		1					KB02B862Z02		
303	S70 E10 110	G	FAN CASE U							KB25A145G01		
304	S70 E30 110	G	FAN CASE U		2					KB25A144G01		
305	S70 E50 110	G	FAN CASE L							KB25A147G01		
306	S70 E40 110	G	FAN CASE L		2					KB25A146G01		
307	S70 E20 114	G	SIROCCO FAN 200 ASSY							KB00R101G01		
308	S70 E32 114	G	SIROCCO FAN 320 ASSY		2					KB00R102G01		
309	S70 L10 105	G	RUBBER MOUNT L							KB31D833H03		
310	S70 R20 105	G	RUBBER MOUNT R		2					KB31D833H04		
311	S70 E10 131	G	ATTACHMENT		2					W353715H01		
312	S70 E20 220	G	MOTOR P40							KB61B961H03		
313	S70 E30 220	G	MOTOR P63							KB61B962H03		
314	S70 E40 220	G	MOTOR P100		1					KB61B963H03		
315	S70 E20 677	G	FAN PLATE ASSY P40							KBT00T067G07		
316	S70 E30 677	G	FAN PLATE ASSY P63							KBT00T067G08		
317	S70 E40 677	G	FAN PLATE ASSY P100							KBT00T067G09		
318	S70 E50 677	G	FAN PLATE ASSY P140		1					KBT00T067G10		

PEAD-RP35,RP50,RP60,RP71JAL.UK  
 PEAD-RP100,RP125JAL.UK

BLOWER PARTS

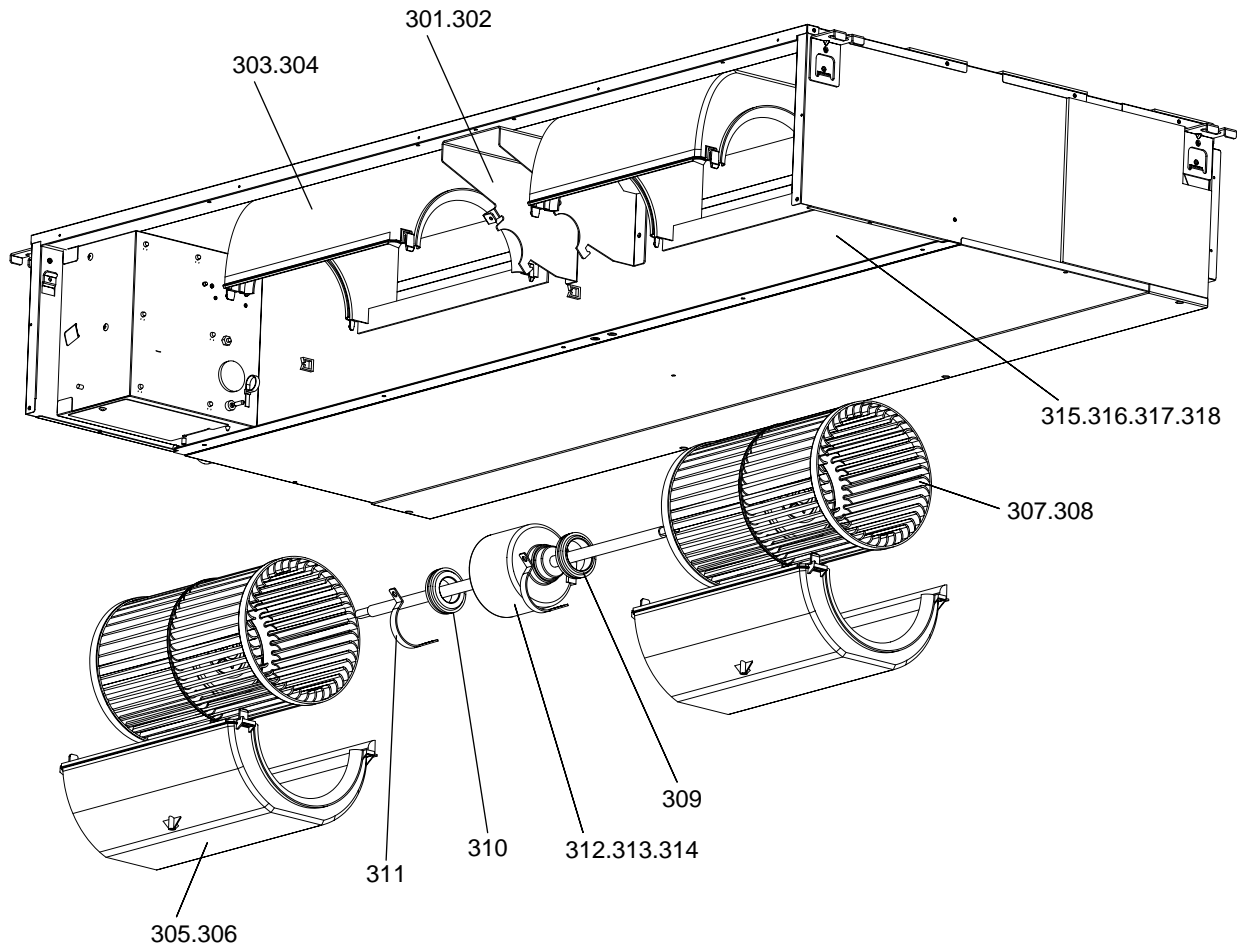

No.	Part No.	G : RoHS Apply Only W : RoHS Apply by Running Change		Spec.	PEAD-RP35JAL.UK	PEAD-RP50JAL.UK	PEAD-RP60JAL.UK	PEAD-RP71JAL.UK	PEAD-RP100JAL.UK	PEAD-RP125JAL.UK	Dwg. No.	Price	Revision History
			Part Name										
301	S70 E30 130	G	MOTOR BASE P20		1	1	1	1			KB02B861Z02		
302	S70 E40 130	G	MOTOR BASE P100						1	1	KB02B862Z02		
303	S70 E10 110	G	FAN CASE U				2	2			KB25A145G01		
304	S70 E30 110	G	FAN CASE U		1	1			2	2	KB25A144G01		
305	S70 E50 110	G	FAN CASE L				2	2			KB25A147G01		
306	S70 E40 110	G	FAN CASE L		1	1			2	2	KB25A146G01		
307	S70 E20 114	G	SIROCCO FAN 200 ASSY				2	2			KB00R101G01		
308	S70 E32 114	G	SIROCCO FAN 320 ASSY		1	1			2	2	KB00R102G01		
309	S70 L10 105	G	RUBBER MOUNT L		1	1	1	1			KB31D833H03		
310	S70 R20 105	G	RUBBER MOUNT R		1	1	1	1	2	2	KB31D833H04		
311	S70 E10 131	G	ATTACHMENT		2	2	2	2	2	2	W353715H01		
312	S70 E20 220	G	MOTOR P40		1	1					KB61B961H03		
313	S70 E30 220	G	MOTOR P63				1	1			KB61B962H03		
314	S70 E40 220	G	MOTOR P100						1	1	KB61B963H03		
315	S70 E20 677	G	FAN PLATE ASSY P40		1	1					KBT00T067G07		
316	S70 E30 677	G	FAN PLATE ASSY P63				1	1			KBT00T067G08		
317	S70 E40 677	G	FAN PLATE ASSY P100						1	1	KBT00T067G09		
318	S70 E50 677	G	FAN PLATE ASSY P140								KBT00T067G10		

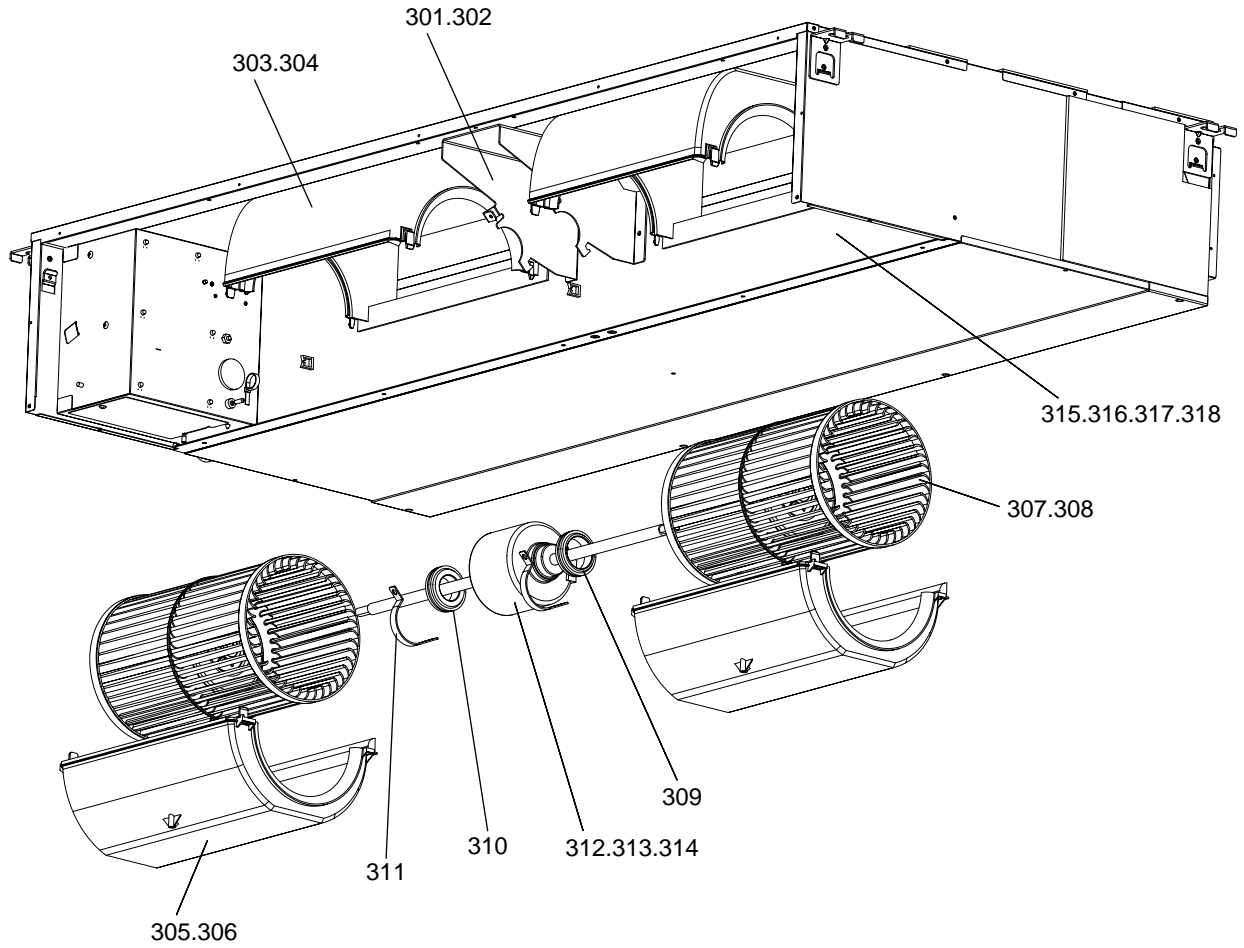

No.	Part No.	G : RoHS Apply Only W : RoHS Apply by Running Change		Spec.	PEAD-RP140JAL.UK					Dwg. No.	Price	Revision History
			Part Name									
301	S70 E30 130	G	MOTOR BASE P20							KB02B861Z02		
302	S70 E40 130	G	MOTOR BASE P100		1					KB02B862Z02		
303	S70 E10 110	G	FAN CASE U							KB25A145G01		
304	S70 E30 110	G	FAN CASE U		2					KB25A144G01		
305	S70 E50 110	G	FAN CASE L							KB25A147G01		
306	S70 E40 110	G	FAN CASE L		2					KB25A146G01		
307	S70 E20 114	G	SIROCCO FAN 200 ASSY							KB00R101G01		
308	S70 E32 114	G	SIROCCO FAN 320 ASSY		2					KB00R102G01		
309	S70 L10 105	G	RUBBER MOUNT L							KB31D833H03		
310	S70 R20 105	G	RUBBER MOUNT R		2					KB31D833H04		
311	S70 E10 131	G	ATTACHMENT		2					W353715H01		
312	S70 E20 220	G	MOTOR P40							KB61B961H03		
313	S70 E30 220	G	MOTOR P63							KB61B962H03		
314	S70 E40 220	G	MOTOR P100		1					KB61B963H03		
315	S70 E20 677	G	FAN PLATE ASSY P40							KBT00T067G07		
316	S70 E30 677	G	FAN PLATE ASSY P63							KBT00T067G08		
317	S70 E40 677	G	FAN PLATE ASSY P100							KBT00T067G09		
318	S70 E50 677	G	FAN PLATE ASSY P140		1					KBT00T067G10		

PEAD-RP35,RP50,RP60,RP71JA.UK  
 PEAD-RP100,RP125JA.UK

CONTROL BOX PARTS

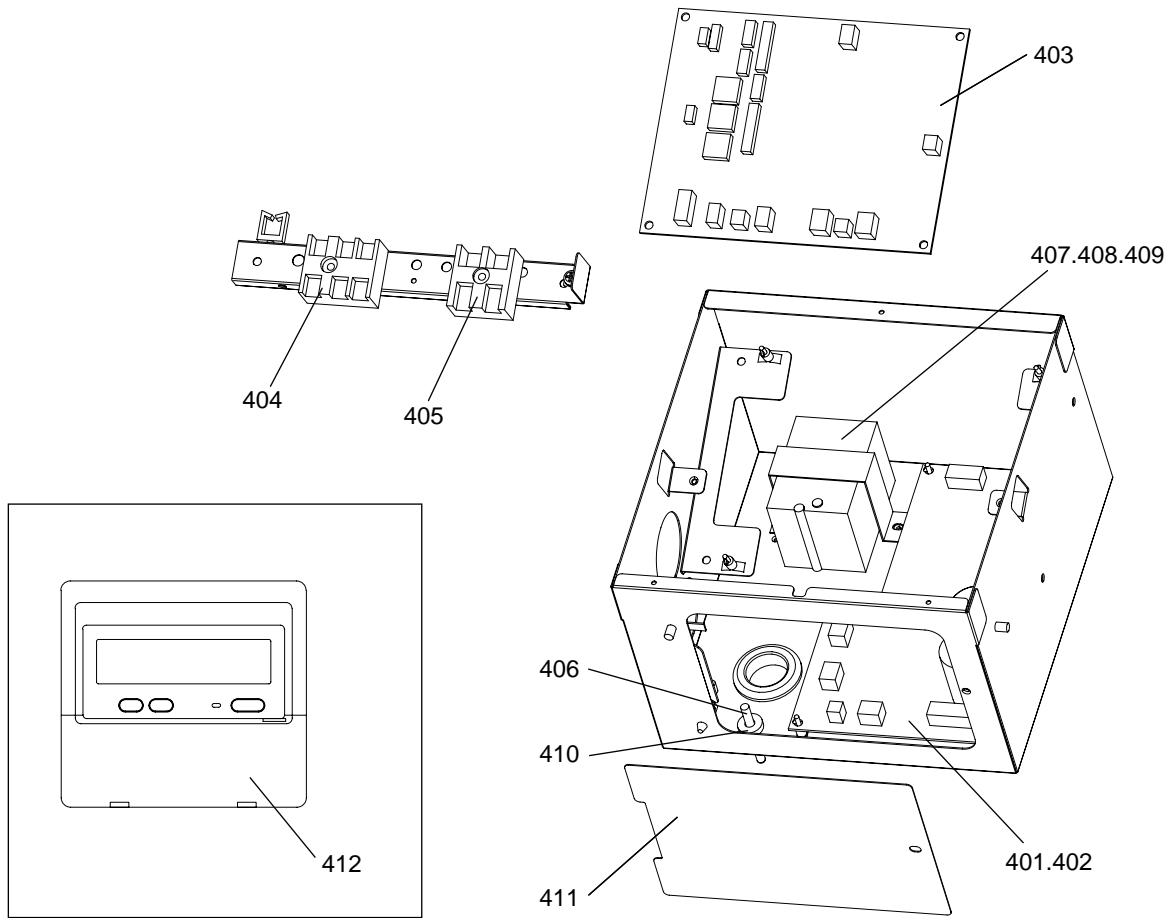

No.	Part No.	G : RoHS Apply Only W : RoHS Apply by Running Change		Spec.	PEAD-RP35JA.UK	PEAD-RP50JA.UK	PEAD-RP60JA.UK	PEAD-RP71JA.UK	PEAD-RP100JA.UK	PEAD-RP125JA.UK	Dwg. No.	Price	Revision History
			Part Name										
401	S70 K30 313	G	PRINTED CIRCUIT ASSEMBLY	PW 3A	1	1	1	1			KE01D548B01		
402	S70 K40 313	G	PRINTED CIRCUIT ASSEMBLY	PW 5A					1	1	KE01D548B02		
403	S70 K20 310	G	PRINTED CIRCUIT ASSEMBLY	INDOOR CONTROL	1	1	1	1	1	1	KE01D547B01		
404	S70 K01 716	G	TERMINAL BLOCK ASSY		1	1	1	1	1	1	BH00C267G02		
405	S70 E40 716	G	TERMINAL BLOCK		1	1	1	1	1	1	BH73L021H01		
406	S70 0B1 202	G	THERMISTOR-S	250XAP	1	1	1	1	1	1	RG71J628H01		
407	S70 K01 529	G	REACTOR	3A3	1	1	1				KE65D486H02		
408	S70 K02 259	G	REACTOR	3A6				1			KE65D487H01		
409	S70 K03 259	G	REACTOR	5A6					1	1	KE65D488H01		
410	S70 E10 306	G	CORD BUSH		1	1	1	1	1	1	BG25U730H01		
411	S70 E14 068	G	BOX UNDER COVER		1	1	1	1	1	1	KB02K887Z01		
412	S70 KW2 713	G	REMOTE CONTROLLER		1	1	1	1	1	1	BG00U396B01		

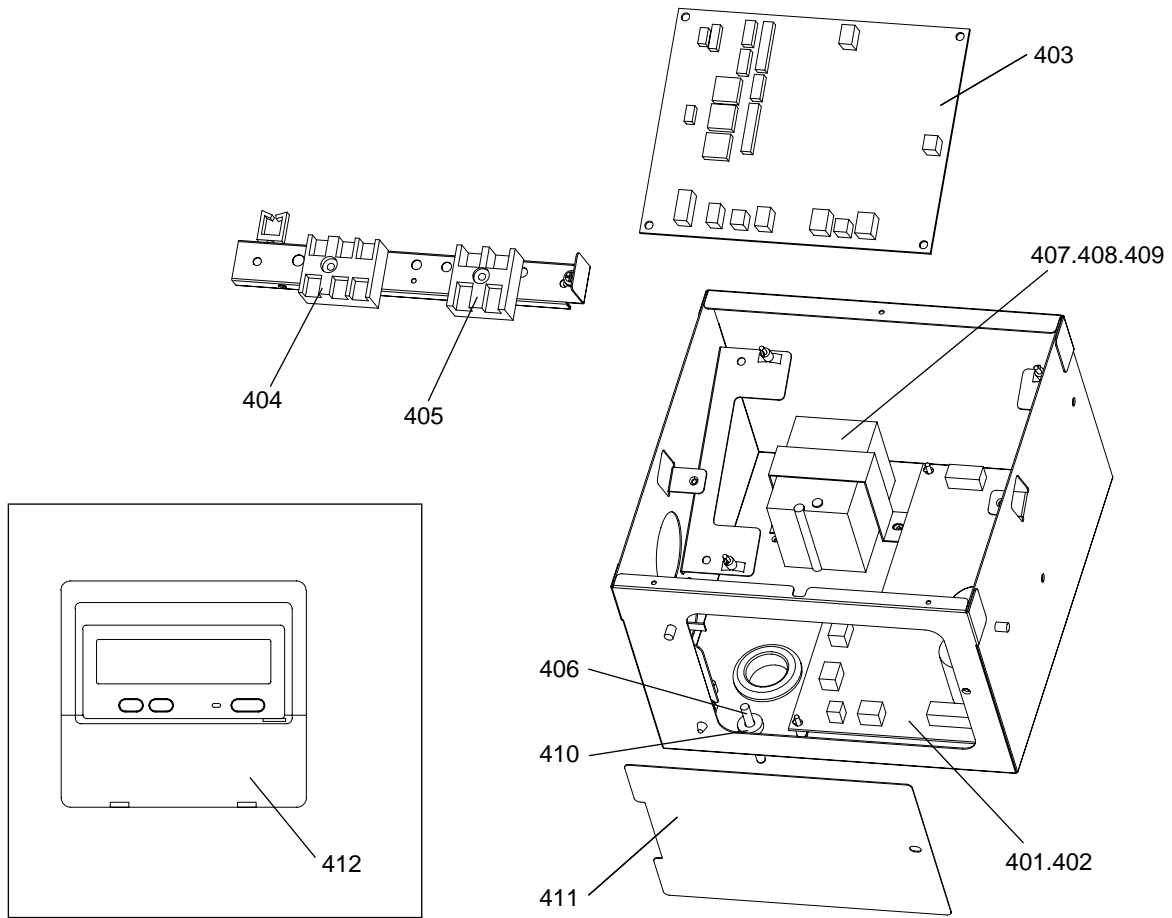

No.	Part No.	G : RoHS Apply Only W : RoHS Apply by Running Change		Spec.	PEAD-RP140JA.UK						Dwg. No.	Price	Revision History
			Part Name										
401	S70 K30 313	G	PRINTED CIRCUIT ASSEMBLY	PW 3A							KE01D548B01		
402	S70 K40 313	G	PRINTED CIRCUIT ASSEMBLY	PW 5A	1						KE01D548B02		
403	S70 K20 310	G	PRINTED CIRCUIT ASSEMBLY	INDOOR CONTROL	1						KE01D547B01		
404	S70 K01 716	G	TERMINAL BLOCK ASSY		1						BH00C267G02		
405	S70 E40 716	G	TERMINAL BLOCK		1						BH73L021H01		
406	S70 0B1 202	G	THERMISTOR-S	250XAP	1						RG71J628H01		
407	S70 K01 529	G	REACTOR	3A3							KE65D486H02		
408	S70 K02 259	G	REACTOR	3A6							KE65D487H01		
409	S70 K03 259	G	REACTOR	5A6	1						KE65D488H01		
410	S70 E10 306	G	CORD BUSH		1						BG25U730H01		
411	S70 E14 068	G	BOX UNDER COVER		1						KB02K887Z01		
412	S70 KW2 713	G	REMOTE CONTROLLER		1						BG00U396B01		

PEAD-RP35,RP50,RP60,RP71JAL.UK  
 PEAD-RP100,RP125JAL.UK

CONTROL BOX PARTS

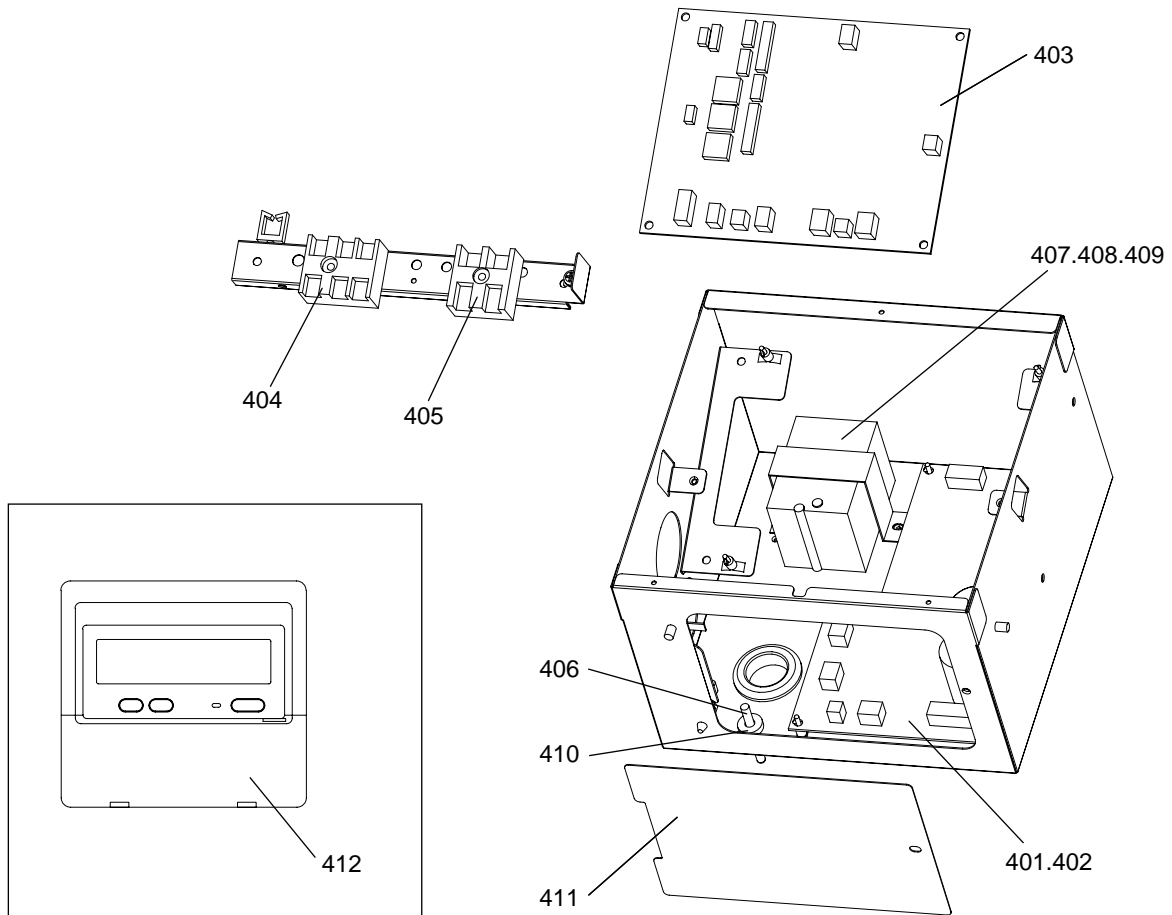

No.	Part No.	G : RoHS Apply Only W : RoHS Apply by Running Change		Spec.	PEAD-RP35JALUK	PEAD-RP50JALUK	PEAD-RP60JALUK	PEAD-RP71JALUK	PEAD-RP100JALUK	PEAD-RP125JALUK	Dwg. No.	Price	Revision History
			Part Name										
401	S70 K30 313	G	PRINTED CIRCUIT ASSEMBLY	PW 3A	1	1	1	1			KE01D548B01		
402	S70 K40 313	G	PRINTED CIRCUIT ASSEMBLY	PW 5A					1	1	KE01D548B02		
403	S70 K20 310	G	PRINTED CIRCUIT ASSEMBLY	INDOOR CONTROL	1	1	1	1	1	1	KE01D547B01		
404	S70 K01 716	G	TERMINAL BLOCK ASSY		1	1	1	1	1	1	BH00C267G02		
405	S70 E40 716	G	TERMINAL BLOCK		1	1	1	1	1	1	BH73L021H01		
406	S70 0B1 202	G	THERMISTOR-S	250XAP	1	1	1	1	1	1	RG71J628H01		
407	S70 K01 529	G	REACTOR	3A3	1	1	1				KE65D486H02		
408	S70 K02 259	G	REACTOR	3A6				1			KE65D487H01		
409	S70 K03 259	G	REACTOR	5A6					1	1	KE65D488H01		
410	S70 E10 306	G	CORD BUSH		1	1	1	1	1	1	BG25U730H01		
411	S70 E14 068	G	BOX UNDER COVER		1	1	1	1	1	1	KB02K887Z01		
412	S70 KW2 713	G	REMOTE CONTROLLER		1	1	1	1	1	1	BG00U396B01		

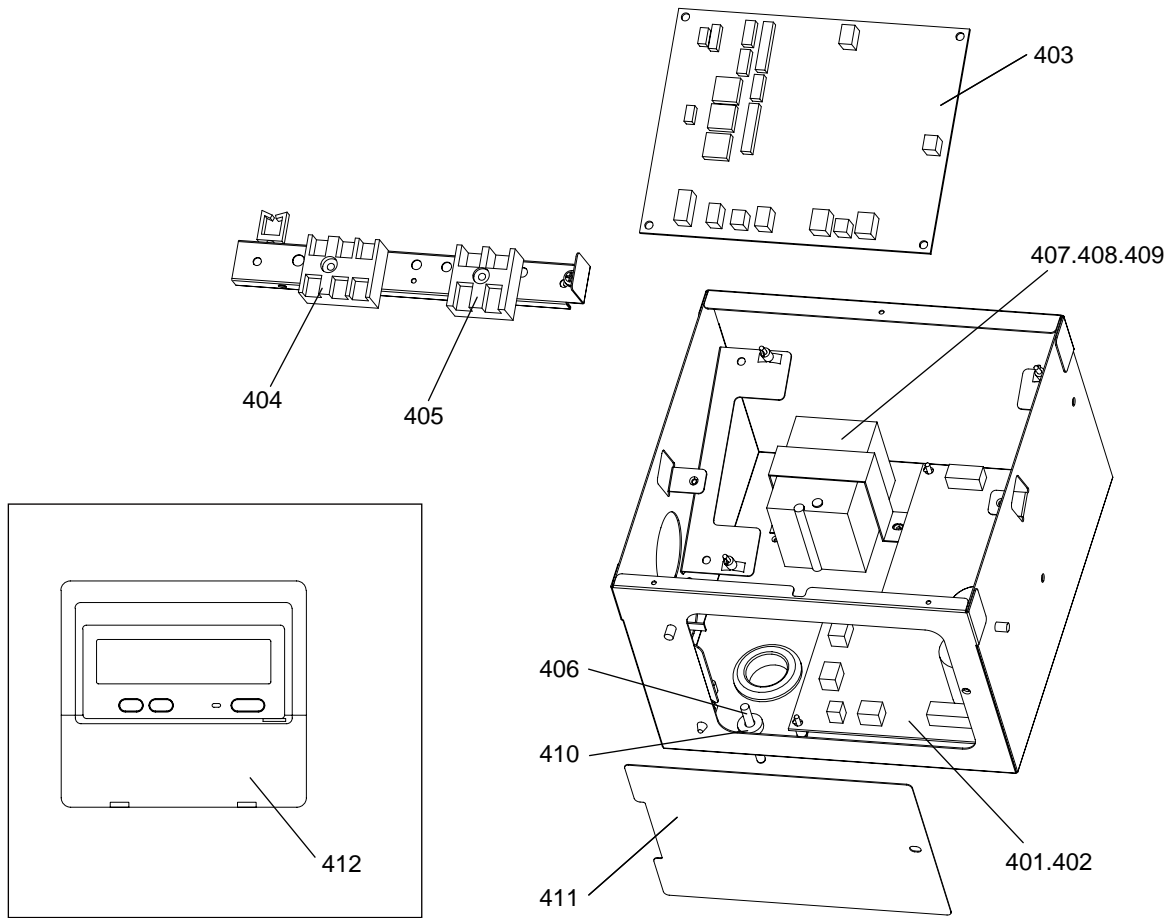

No.	Part No.	G : RoHS Apply Only W : RoHS Apply by Running Change		Spec.	PEAD-RP-140JAL.UK						Dwg. No.	Price	Revision History
			Part Name										
401	S70 K30 313	G	PRINTED CIRCUIT ASSEMBLY	PW 3A							KE01D548B01		
402	S70 K40 313	G	PRINTED CIRCUIT ASSEMBLY	PW 5A	1						KE01D548B02		
403	S70 K20 310	G	PRINTED CIRCUIT ASSEMBLY	INDOOR CONTROL	1						KE01D547B01		
404	S70 K01 716	G	TERMINAL BLOCK ASSY		1						BH00C267G02		
405	S70 E40 716	G	TERMINAL BLOCK		1						BH73L021H01		
406	S70 0B1 202	G	THERMISTOR-S	250XAP	1						RG71J628H01		
407	S70 K01 529	G	REACTOR	3A3							KE65D486H02		
408	S70 K02 259	G	REACTOR	3A6							KE65D487H01		
409	S70 K03 259	G	REACTOR	5A6	1						KE65D488H01		
410	S70 E10 306	G	CORD BUSH		1						BG25U730H01		
411	S70 E14 068	G	BOX UNDER COVER		1						KB02K887Z01		
412	S70 KW2 713	G	REMOTE CONTROLLER		1						BG00U396B01		

