

**SPLIT-TYPE, HEAT PUMP
AIR CONDITIONERS**

2005

SERVICE MANUAL

Series PEAD Ceiling Concealed R407C/R410A

<indoor unit> Service ref.

Models PEAD-RP35EA(2)
PEAD-RP50EA
PEAD-RP60EA
PEAD-RP71EA
PEAD-RP100EA(2)
PEAD-RP125EA
PEAD-RP140EA

NOTE:

- This manual describes only service data of the indoor units.

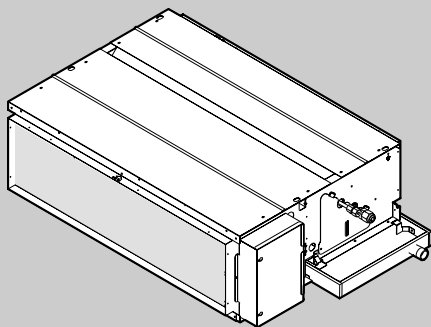

INDOOR UNIT

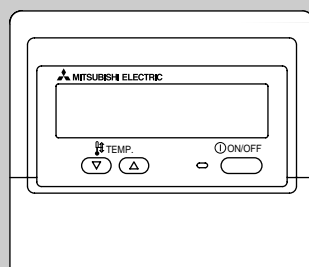

REMOTE CONTROLLER

CONTENTS

1. REFERENCE MANUAL	2
2. SAFETY PRECAUTION	3
3. PART NAMES AND FUNCTIONS	7
4. SPECIFICATION	9
5. FAN PERFORMANCE AND CORRECTED AIR FLOW	12
6. SOUND LEVELS	16
7. OUTLINES & DIMENSIONS	18
8. WIRING DIAGRAM	20
9. REFRIGERANT SYSTEM DIAGRAM	21
10. TROUBLESHOOTING	22
11. DISASSEMBLY INSTRUCTIONS	34
12. PARTS LIST	36
13. OPTIONAL PARTS	42

1**REFERENCE MANUAL****1-1. OUTDOOR UNIT'S SERVICE MANUAL**

Service Ref.	Service Manual No.
PUHZ-RP35/50/60/71/100/125/140VHA PUHZ-RP100/125/140YHA	OC334
PUHZ-RP71/100/125/140VHA-A	OC337
PUHZ-RP200/250YHA	OC338
PUHZ-RP200/250YHA-A	OC339
PUHZ-P100/125/140VHA.UK	OC359
PU(H)-P.VGAA.UK PU(H)-P.YGAA.UK	OC336
SUZ-KA.VA.TH	OC322

1-2. TECHNICAL DATA BOOK

Series (Outdoor unit)	Manual No.
PUHZ-RP.VHA(-A) PUHZ-RP.YHA(-A)	OCS01
PUHZ-P.VHA.UK	OCS06
PU(H)-P.VGAA.UK PU(H)-P.YGAA.UK	OCS02

2

SAFETY PRECAUTION

CAUTIONS RELATED TO NEW REFRIGERANT

Caution for units utilising refrigerant R407C

Do not use the existing refrigerant piping.

The old refrigerant and lubricant in the existing piping contains a large amount of chlorine which may cause the lubricant deterioration of the new unit.

Use "low residual oil piping"

If there is a large amount of residual oil (hydraulic oil, etc.) inside the piping and joints, deterioration of the lubricant will result.

Store the piping to be used during installation indoors with keep both ends sealed until just before brazing. (Store elbows and other joints in a plastic bag.)

If dust, dirt, or water enters the refrigerant cycle, deterioration of the oil and compressor trouble may result.

Use ESTER , ETHER or HAB as the lubricant to coat flares and flange connection parts.

If large amount of mineral oil enter, that can cause deterioration of refrigerant oil etc.

Use liquid refrigerant to charge the system.

If gas refrigerant is used to seal the system, the composition of the refrigerant in the cylinder will change and performance may drop.

Do not use a refrigerant other than R407C.

If another refrigerant (R22, etc.) is used, the chlorine in the refrigerant may cause the lubricant deterioration.

Use a vacuum pump with a reverse flow check valve.

The vacuum pump oil may flow back into the refrigerant cycle and cause the lubricant deterioration.

Ventilate the room if refrigerant leaks during operation. If refrigerant comes into contact with a flame, poisonous gases will be released.

[1] Cautions for service

- After recovering the all refrigerant in the unit, proceed to working.
- Do not release refrigerant in the air.
- After completing the repair service, recharge the cycle with the specified amount of liquid refrigerant.

[2] Refrigerant recharging

(1) Refrigerant recharging process

① Direct charging from the cylinder.

- R407C cylinder are available on the market has a syphon pipe.
 - Leave the syphon pipe cylinder standing and recharge it.
- (By liquid refrigerant)

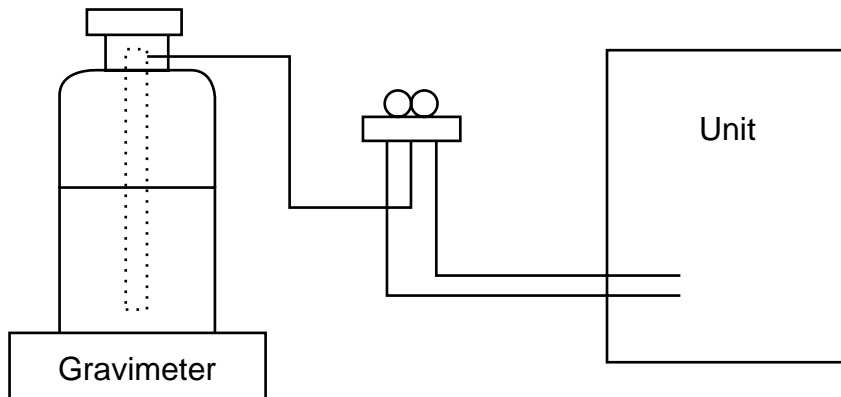

(2) Recharge in refrigerant leakage case

- After recovering the all refrigerant in the unit, proceed to working.
- Do not release the refrigerant in the air.
- After completing the repair service, recharge the cycle with the specified amount of liquid refrigerant.

[3] Service tools

Use the below service tools as exclusive tools for R407C refrigerant.

No.	Tool name	Specifications
①	Gauge manifold	·Only for R407C.
		·Use the existing fitting SPECIFICATIONS. (UNF7/16)
		·Use high-tension side pressure of 3.43MPa·G or over.
②	Charge hose	·Only for R407C.
		·Use pressure performance of 5.10MPa·G or over.
③	Electronic scale	
④	Gas leak detector	·Use the detector for R134a or R407C.
⑤	Adapter for reverse flow check.	·Attach on vacuum pump.
⑥	Refrigerant charge base.	
⑦	Refrigerant cylinder.	·For R407C ·Top of cylinder (Brown)
		·Cylinder with syphon
⑧	Refrigerant recovery equipment.	

CAUTIONS RELATED TO NEW REFRIGERANT

<Cautions for units utilizing refrigerant R410A>

Use new refrigerant pipes.

In case of using the existing pipes for R22, be careful with the following.

- For RP100,125 and 140 be sure to perform pipe replacement operation before test run.
- Use flare nut as provided with this product. Use a newly flared pipe.
- Avoid using thin pipes. For the detail, please refer to the outdoor unit service manual.

Make sure that the inside and outside of refrigerant piping is clean and it has no contamination such as sulfur which is hazardous for use, oxides, dirt, shaving particles, etc. In addition, use pipes with specified thickness.

Contamination inside refrigerant piping can cause deterioration of refrigerant oil etc.

Store the piping to be used during installation indoors and keep both ends of the piping sealed until just before brazing. (Leave elbow joints, etc. in their packaging.)

If dirt, dust or moisture enter into refrigerant cycle, that can cause deterioration of refrigerant oil or malfunction of compressor.

Use ester oil, ether oil or alkylbenzene oil (small amount) as the refrigerant oil applied to flares and flange connections.

If large amount of mineral oil enter, that can cause deterioration of refrigerant oil etc.

Charge refrigerant from liquid phase of gas cylinder.

If the refrigerant is charged from gas phase, composition change may occur in refrigerant and the efficiency will be lowered.

Do not use refrigerant other than R410A.

If other refrigerant (R22 etc.) is used, chlorine in refrigerant can cause deterioration of refrigerant oil etc.

Use a vacuum pump with a reverse flow check valve.

If no reverse flow check valve is used, vacuum pump oil may flow back into refrigerant cycle and that can cause deterioration of refrigerant oil etc.

Use the following tools specifically designed for use with R410A refrigerant.

The following tools are necessary to use R410A refrigerant.

Tools (for R410A)	
Gauge manifold	Flare tool
Charge hose	Size adjustment gauge
Gas leak detector	Vacuum pump adaptor
Torque wrench	Electronic refrigerant charging scale

Keep the tools with care.

If dirt, dust or moisture enter into refrigerant cycle, that can cause deterioration of refrigerant oil or malfunction of compressor.

Do not use a charging cylinder without syphone tube.

If a charging cylinder is used without syphone tube, the composition of refrigerant will change and the efficiency will be lowered.

Ventilate the room if refrigerant leaks during operation. If refrigerant comes into contact with a flame, poisonous gases will be released.

[1] Cautions for installing or relocation of unit

- (1) Perform service after collecting the refrigerant left in unit completely.
- (2) Do not release refrigerant in the air.
- (3) After completing service, charge the system with the specified amount of refrigerant.
- (4) When performing service, install a filter drier simultaneously.
Be sure to use a filter drier for new refrigerant.

[2] Additional refrigerant charge

When charging directly from cylinder

Ensure that the cylinder for R410A is syphon type.

Charging should be performed with the syphon cylinder type stood vertically.

(Refrigerant must be charged from liquid phase.)

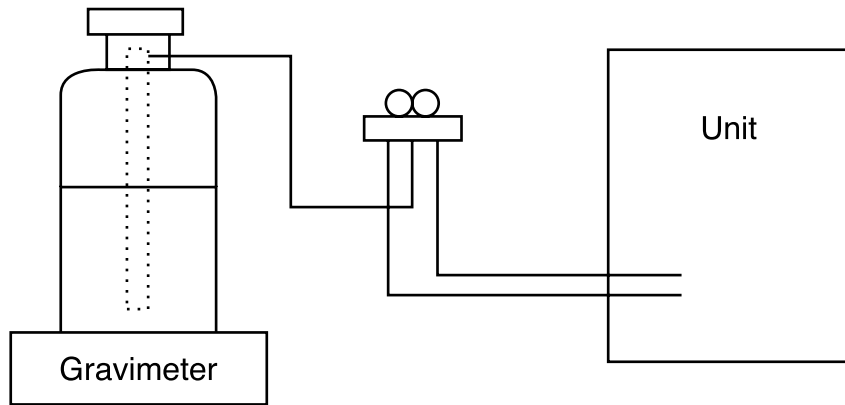

[3] Service tools

Use the below service tools as exclusive tools for R410A refrigerant.

No.		Specifications
①	Gauge manifold	• Only for R410A
		• Use the existing fitting specifications. (UNF1/2)
		• Use high-tension side pressure of 5.3MPa-G or over.
②	Charge hose	• Only for R410A
		• Use pressure performance of 5.09MPa-G or over.
③	Electronic scale	—
④	Gas leak detector	• Use the detector for R134a, R407C or R410A.
⑤	Adaptor for reverse flow check	• Attach on vacuum pump.
⑥	Refrigerant charge base	—
⑦	Refrigerant cylinder	• Only for R410A Top of cylinder (Pink) Cylinder with syphon
⑧	Refrigerant recovery equipment	—

3

PART NAMES AND FUNCTIONS

• Indoor Unit

Air intake (sucks the air inside the room into the unit)

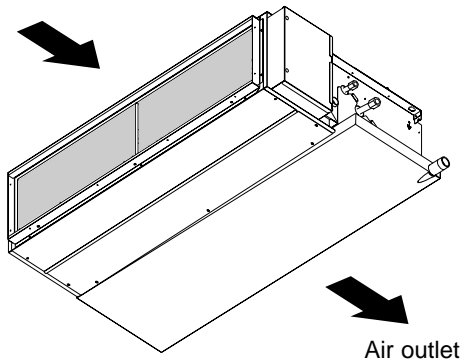

In case of rear inlet

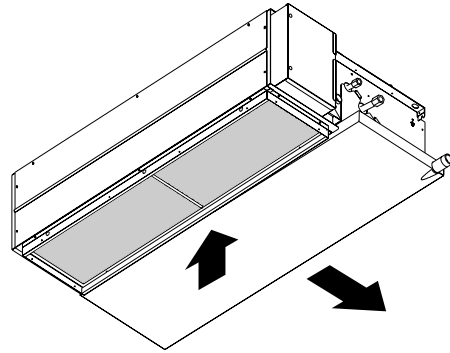

In case of bottom inlet
(Only RP35~60EA)
RP35EA2

• Remote controller

Once the controls are set, the same operation mode can be repeated by simply pressing the ON/OFF button.

• Operation buttons

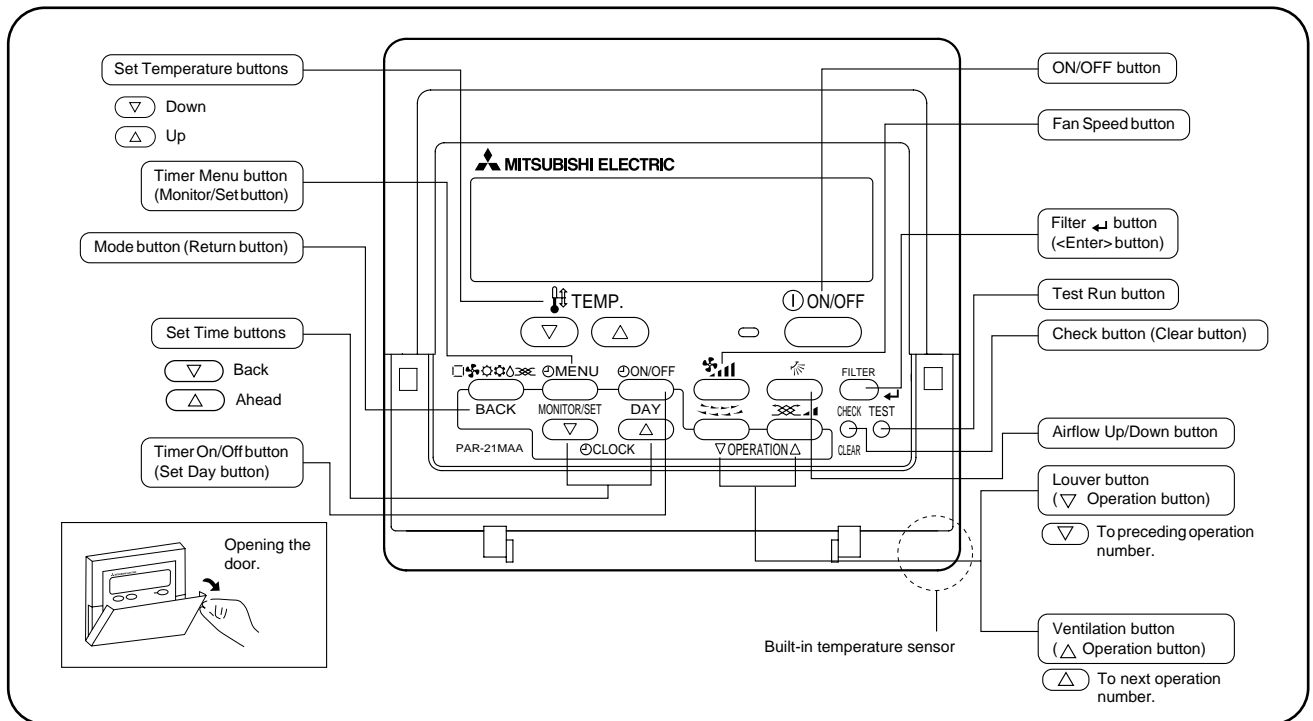

• Display

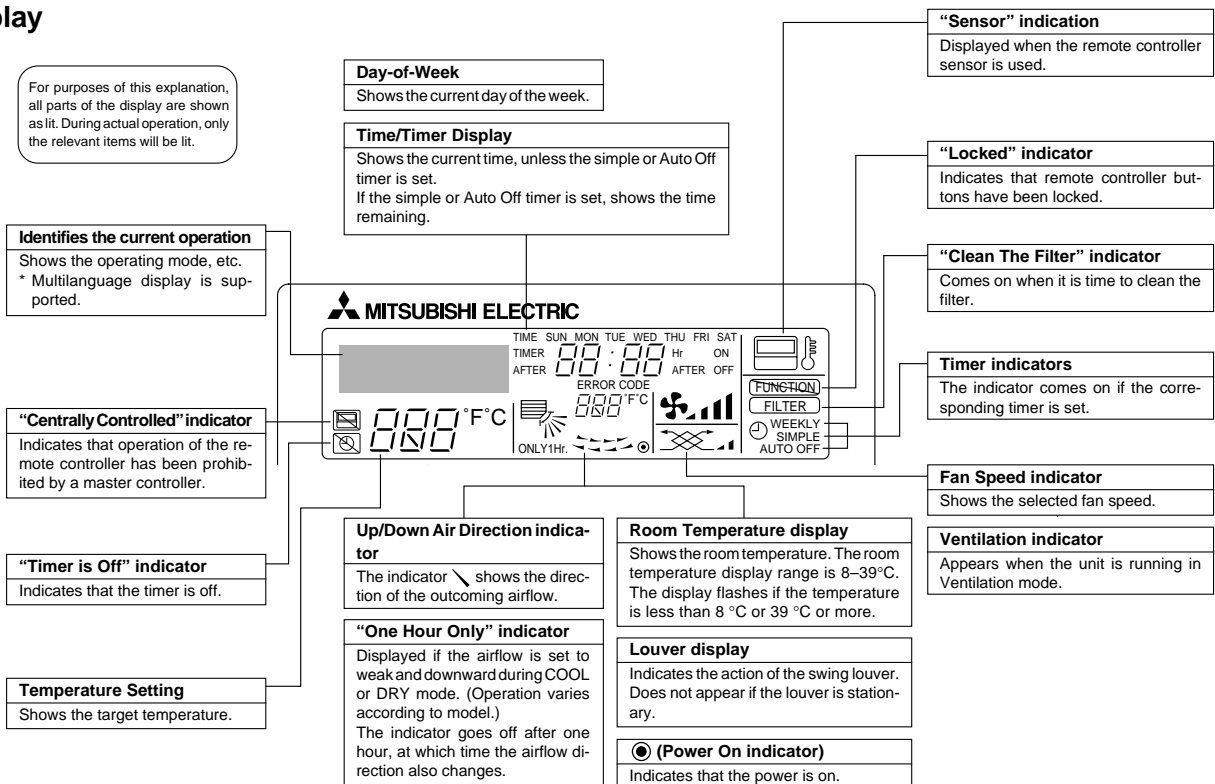

Caution

- Only the Power on indicator lights when the unit is stopped and power supplied to the unit.
- If you press a button for a feature that is not installed at the indoor unit, the remote controller will display the “Not Available” message.
If you are using the remote controller to drive multiple indoor units, this message will appear only if the feature is not present at the parent unit.
- When power is turned ON for the first time, it is normal that “PLEASE WAIT” is displayed on the room temperature indication (For max. 2minutes). Please wait until this “PLEASE WAIT” indication disappears then start the operation.

4

SPECIFICATION

Service Ref.			PEAD-RP35EA	PEAD-RP35EA2
Power supply			Single phase, 50Hz, 220-240V	
Input	* 1	kW	0.13	0.14
	* 1	A	0.55	0.61
	* 1	A	0.8	0.9
External finish			Galvanized sheets	
Heat exchanger			Plate fin coil	
Fan	Fan (drive) × No.		Centrifugal (direct) × 2	
	Fan motor output	kW	0.043	0.076
	Airflow (Lo-Hi)	m ³ /min <CFM>	11-14<388-494>	13.5-17<477-600>
	External static pressure	Pa	30/70	
Booster heater * 1			-	
Operation control & Thermostat			Built in remote controller	
Noise level (Lo-Hi)	dB (A)	30Pa	34-38	36-40
		70Pa	36-43	38-44
Unit drain pipe O.D			R1 (External thread)	
Dimensions	W	mm (in.)	935 (36-13/16)	
	D	mm (in.)	700 (27-5/8)	
	H	mm (in.)	295 (11-5/8)	
Weight			33 (73)	

Service Ref.			PEAD-RP50EA	
Power supply			Single phase, 50Hz, 220-240V	
Input	* 1	kW	0.14	
	* 1	A	0.61	
	* 1	A	0.9	
External finish			Galvanized sheets	
Heat exchanger			Plate fin coil	
Fan	Fan (drive) × No.		Centrifugal (direct) × 2	
	Fan motor output	kW	0.076	
	Airflow (Lo-Hi)	m ³ /min <CFM>	13.5-17<477-600>	
	External static pressure	Pa	30/70	
Booster heater * 1			-	
Operation control & Thermostat			Built in remote controller	
Noise level (Lo-Hi)	dB (A)	30Pa	36-40	
		70Pa	38-44	
Unit drain pipe O.D			R1 (External thread)	
Dimensions	W	mm (in.)	935 (36-13/16)	
	D	mm (in.)	700 (27-5/8)	
	H	mm (in.)	295 (11-5/8)	
Weight			35 (77)	

Service Ref.			PEAD-RP60EA	
Power supply			Single phase, 50Hz, 220-240V	
Input	* 1	kW	0.16	
	* 1	A	0.70	
	* 1	A	1.0	
External finish			Galvanized sheets	
Heat exchanger			Plate fin coil	
Fan	Fan (drive) × No.		Centrifugal (direct) × 2	
	Fan motor output	kW	0.116	
	Airflow (Lo-Hi)	m ³ /min <CFM>	17-21<600-741>	
	External static pressure	Pa	30/70	
Booster heater * 1			-	
Operation control & Thermostat			Built in remote controller	
Noise level (Lo-Hi)	dB (A)	30Pa	37-41	
		70Pa	39-46	
Unit drain pipe O.D			R1 (External thread)	
Dimensions	W	mm (in.)	1,175 (46-1/8)	
	D	mm (in.)	700 (27-5/8)	
	H	mm (in.)	295 (11-5/8)	
Weight			42 (92)	

Notes 1. Above data based on indicated voltage
 Indoor Unit: Single phase 230V 50Hz
 Outdoor Unit: Single phase 230V 50Hz/3 phase 400V 50Hz

INDOOR UNIT	Service Ref.		PEAD-RP71EA	
	Power supply		Single phase, 50Hz, 220-240V	
	Input	* 1 kW	0.35	
	Running current	* 1 A	1.55	
	Starting current	* 1 A	2.0	
	External finish		Galvanized sheets	
	Heat exchanger		Plate fin coil	
	Fan	Fan (drive) × No.		Centrifugal (direct) × 2
		Fan motor output	kW	0.15
		Airflow (Lo-Hi)	m ³ /min <CFM>	20-25<706-883>
		External static pressure	Pa	70/(130)
	Booster heater	* 1 kW	-	
	Operation control & Thermostat		Built in remote controller	
	Noise level (Lo-Hi)	dB (A)	70Pa	37-41
			(130Pa)	40-45
Unit drain pipe O.D		mm (in.)	R1 (External thread)	
Dimensions	W	mm (in.)	1,175 (46-1/8)	
	D	mm (in.)	740 (29-1/8)	
	H	mm (in.)	325 (12-13/16)	
Weight		kg (lbs)	44 (97)	

INDOOR UNIT	Service Ref.		PEAD-RP100EA	PEAD-RP100EA ₂	
	Power supply		Single phase, 50Hz, 220-240V		
	Input	* 1 kW	0.57	0.59	
	Running current	* 1 A	2.53	2.62	
	Starting current	* 1 A	3.2	3.4	
	External finish		Galvanized sheets		
	Heat exchanger		Plate fin coil		
	Fan	Fan (drive) × No.		Centrifugal (direct) × 2	
		Fan motor output	kW	0.24	0.27
		Airflow (Lo-Hi)	m ³ /min <CFM>	27-34<953-1,200>	33.5-42<1,183-1,483>
		External static pressure	Pa	70/(130)	
	Booster heater	* 1 kW	-		
	Operation control & Thermostat		Built in remote controller		
	Noise level (Lo-Hi)	dB (A)	70Pa	41-46	44-50
			(130Pa)	42-48	46-52
Unit drain pipe O.D		mm (in.)	R1 (External thread)		
Dimensions	W	mm (in.)	1,415 (55-11/16)		
	D	mm (in.)	740 (29-1/8)		
	H	mm (in.)	325 (12-13/16)		
Weight		kg (lbs)	62 (136)	65 (143)	

INDOOR UNIT	Service Ref.		PEAD-RP125EA	
	Power supply		Single phase, 50Hz, 220-240V	
	Input	* 1 kW	0.59	
	Running current	* 1 A	2.62	
	Starting current	* 1 A	3.4	
	External finish		Galvanized sheets	
	Heat exchanger		Plate fin coil	
	Fan	Fan (drive) × No.		Centrifugal (direct) × 2
		Fan motor output	kW	0.27
		Airflow (Lo-Hi)	m ³ /min <CFM>	33.5-42<1,183-1,483>
		External static pressure	Pa	70/(130)
	Booster heater	* 1 kW	-	
	Operation control & Thermostat		Built in remote controller	
	Noise level (Lo-Hi)	dB (A)	70Pa	44-50
			(130Pa)	46-52
Unit drain pipe O.D		mm (in.)	R1 (External thread)	
Dimensions	W	mm (in.)	1,415 (55-11/16)	
	D	mm (in.)	740 (29-1/8)	
	H	mm (in.)	325 (12-13/16)	
Weight		kg (lbs)	65 (143)	

Notes 1. Above data based on indicated voltage
Indoor Unit: Single phase 230V 50Hz
Outdoor Unit: Single phase 230V 50Hz/3 phase 400V 50Hz

INDOOR UNIT	Service Ref.		PEAD-RP140EA
	Power supply		Single phase, 50Hz, 220-240V
	Input	* 1 kW	0.61
	Running current	* 1 A	2.69
	Starting current	* 1 A	3.5
	External finish		Galvanized sheets
	Heat exchanger		Plate fin coil
	Fan	Fan (drive) × No.	Centrifugal (direct) × 2
		Fan motor output kW	0.27
		Airflow (Lo-Hi) m ³ /min <CFM>	36.5-46<1,288-1,624>
		External static pressure Pa	70/(130)
	Booster heater	* 1 kW	-
	Operation control & Thermostat		Built in remote controller
	Noise level (Lo-Hi)	dB (A)	70Pa 46-51
			(130Pa) 47-53
	Unit drain pipe O.D		mm (in.) R1 (External thread)
Dimensions	W	mm (in.) 1,715 (67-1/2)	
	D	mm (in.) 740 (29-1/8)	
	H	mm (in.) 325 (12-13/16)	
Weight	kg (lbs)	70 (154)	

Notes 1. Above data based on indicated voltage
Indoor Unit: Single phase 230V 50Hz
Outdoor Unit: Single phase 230V 50Hz/3 phase 400V 50Hz

5

FAN PERFORMANCE AND CORRECTED AIR FLOW

PEAD-RP35EA

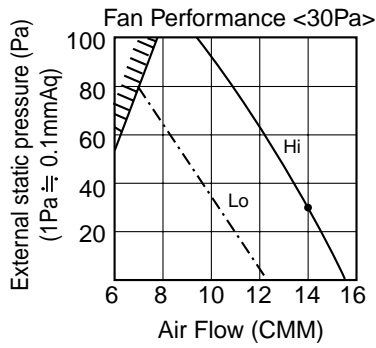

Corrected Air Flow — Capacity input
 ----- input

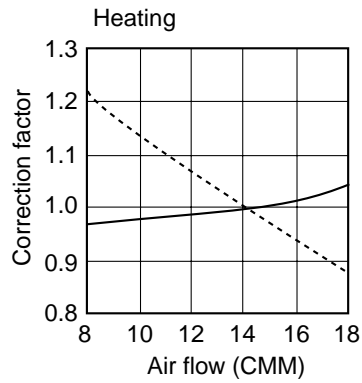
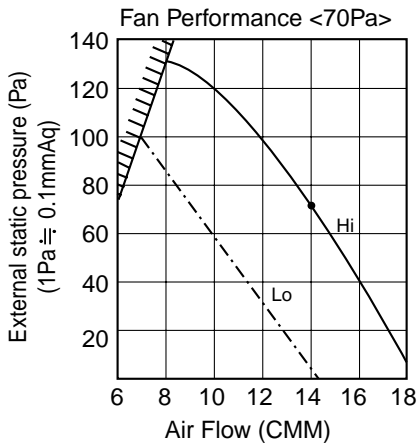
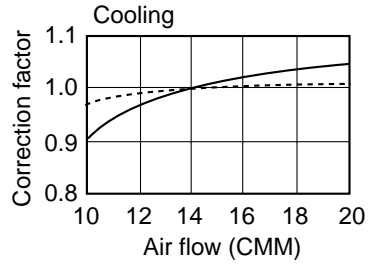

PEAD-RP50EA, PEAD-RP35EA2

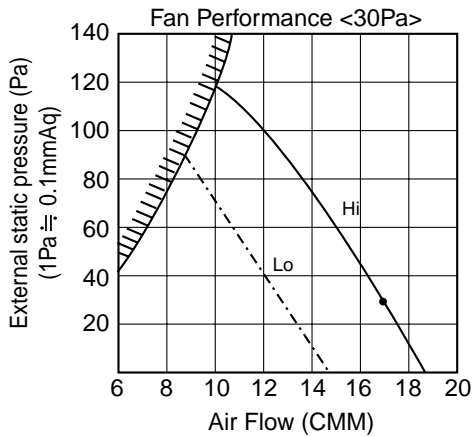

Corrected Air Flow — Capacity input
 ----- input

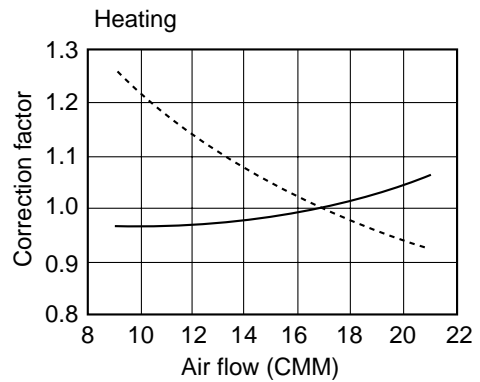
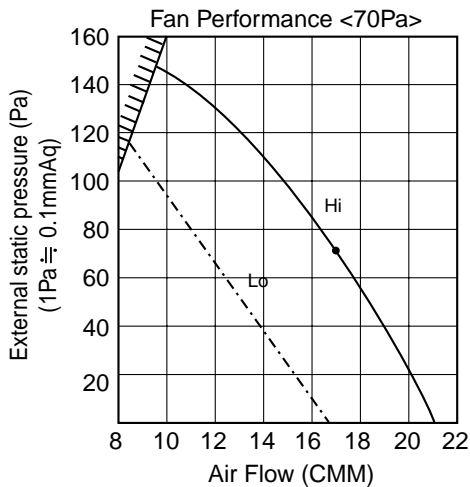
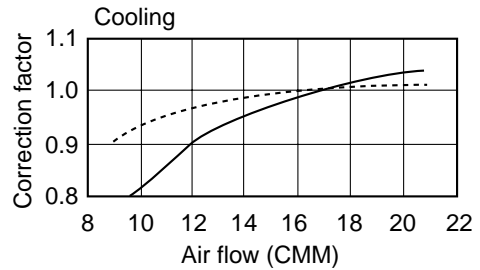

PEAD-RP60EA

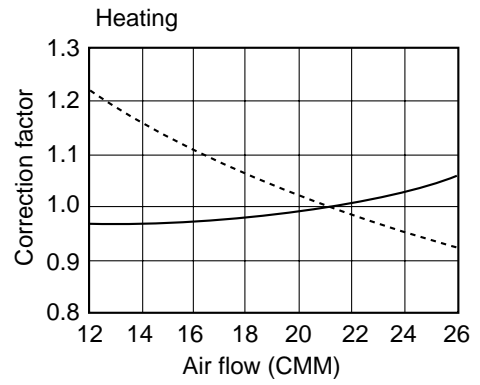
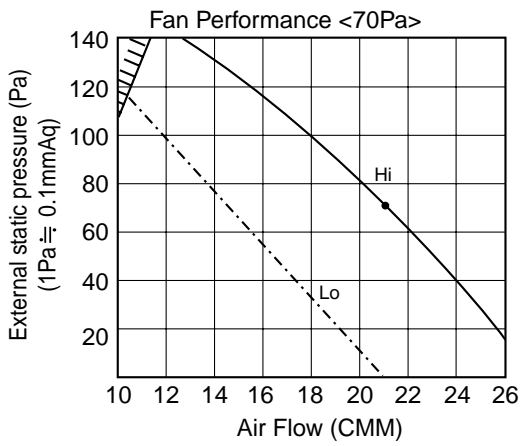
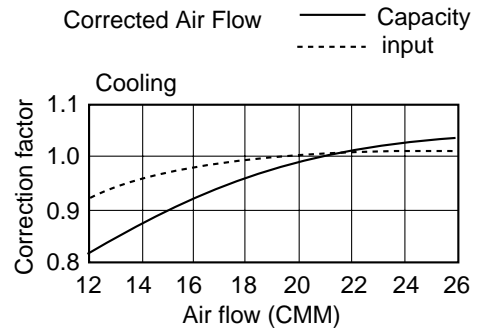
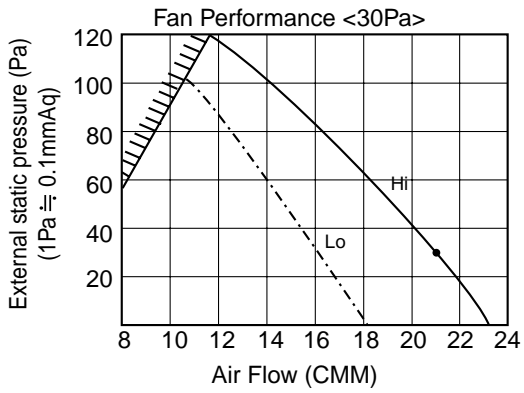

PEAD-RP71EA

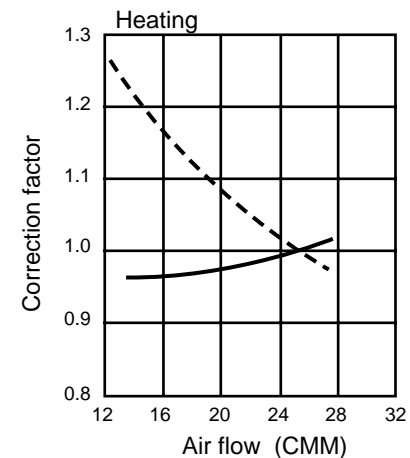
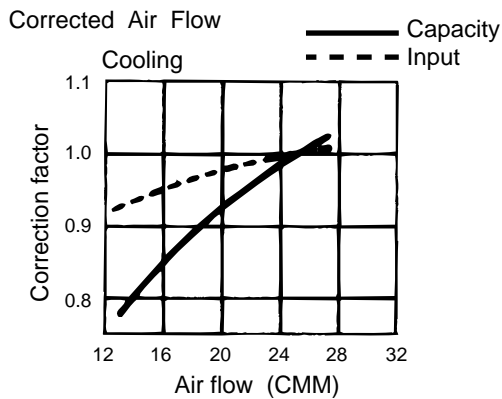
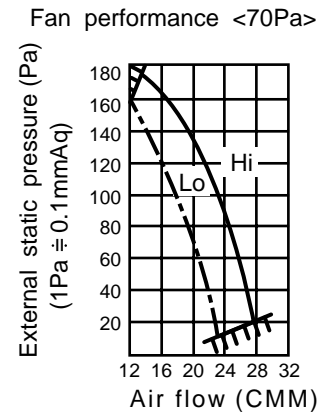
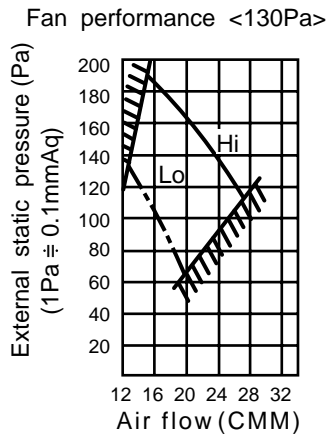

PEAD-RP100EA

Fan performance <130Pa>

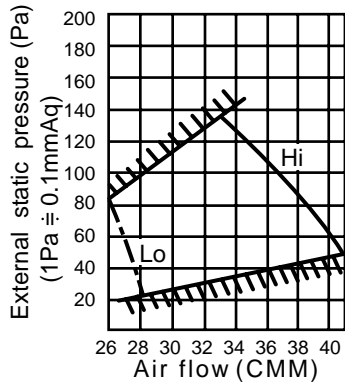

Fan performance <70Pa>

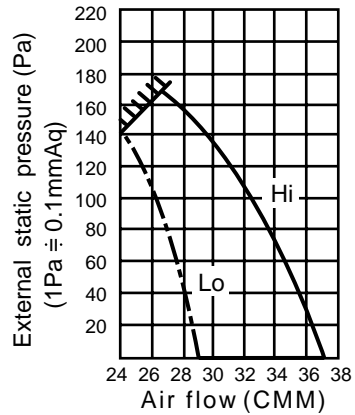

Corrected Air Flow

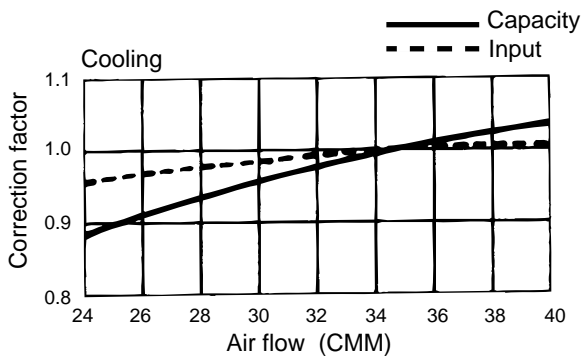

Heating

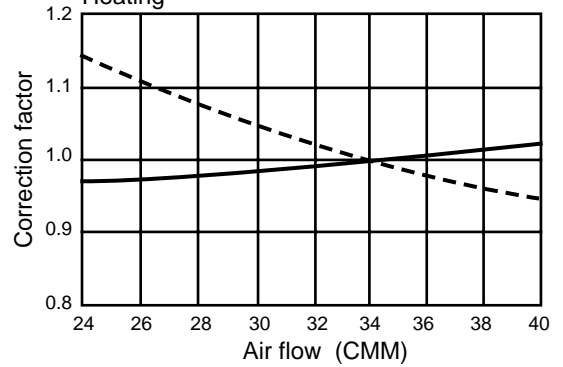

PEAD-RP125EA, PEAD-RP100EA2

Fan performance <130Pa>

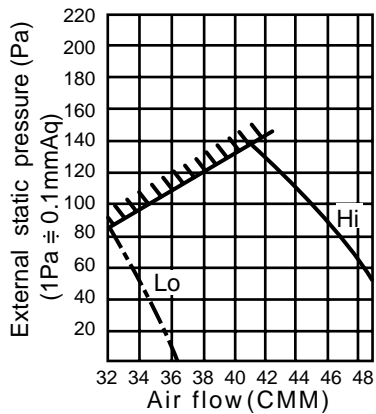

Fan performance <70Pa>

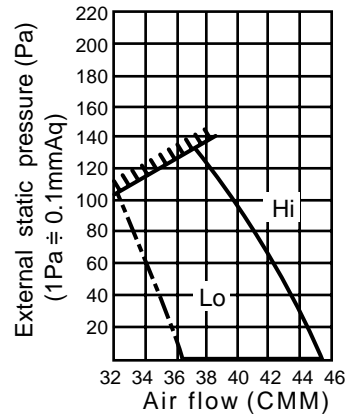

Corrected Air Flow

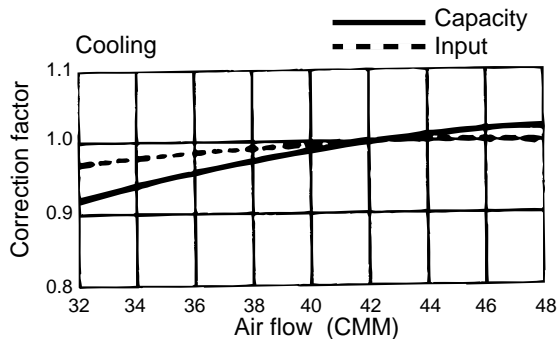

Heating

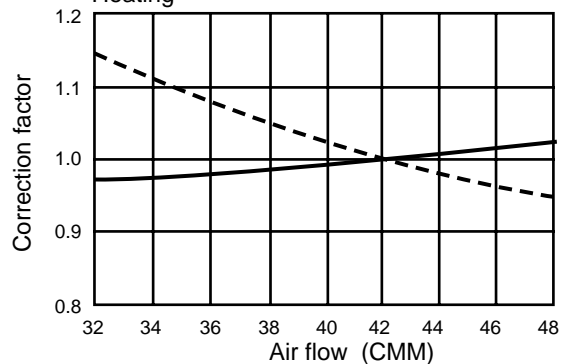

PEAD-RP140EA

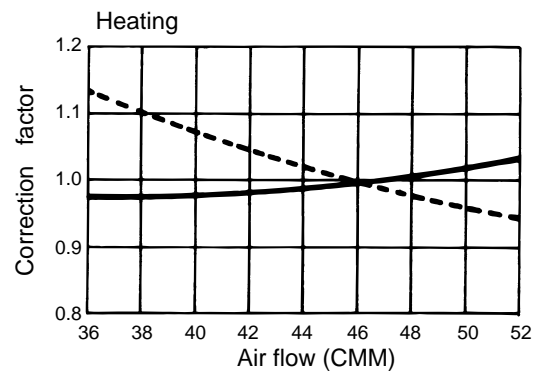
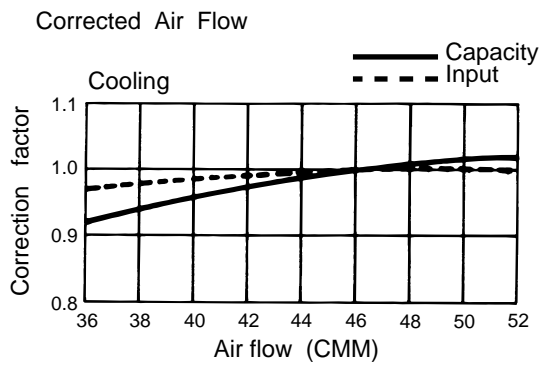
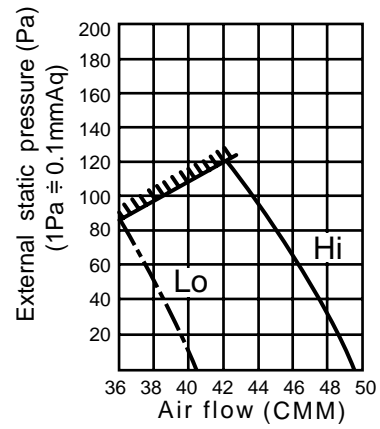
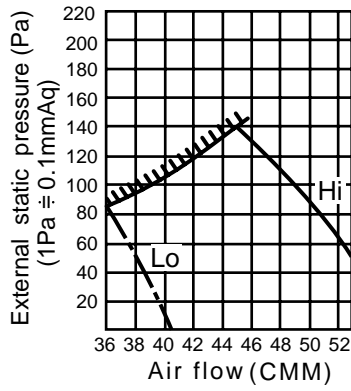

6

SOUND LEVELS

1) Noise level

Ceiling concealed

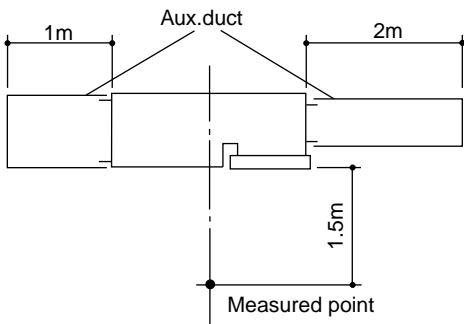

Noise level at anechoic room (Low-High)

Unit : dB(A)

Model	External static pressure		
	30Pa	70Pa	130Pa
PEAD-RP35EA	34-38	36-43	-
PEAD-RP50EA PEAD-RP35EA ₂	36-40	38-44	-
PEAD-RP60EA	37-41	39-46	-
PEAD-RP71EA	-	37-41	40-45 *
PEAD-RP100EA	-	41-46	42-48 *
PEAD-RP125EA PEAD-RP100EA ₂	-	44-50	46-52 *
PEAD-RP140EA	-	46-51	47-53 *

* Optional motor

2) NC curves

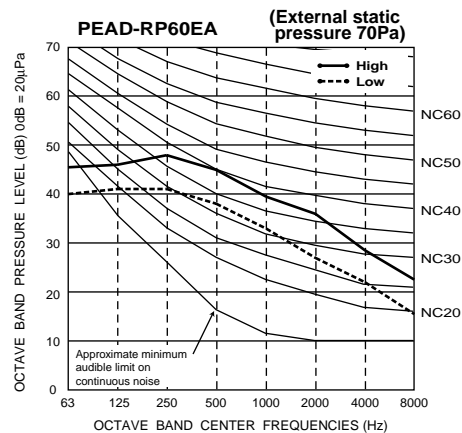
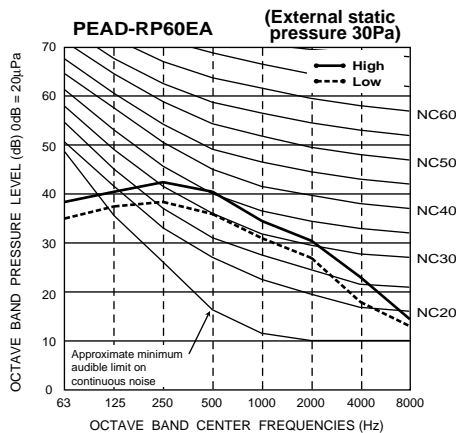
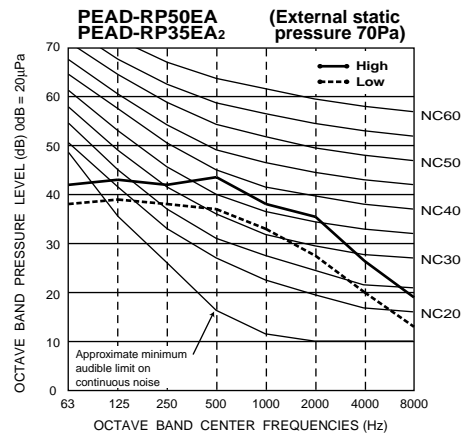
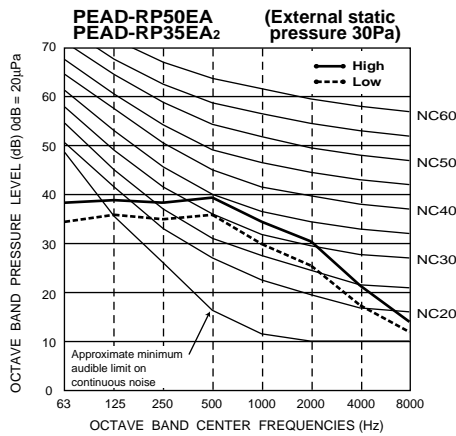
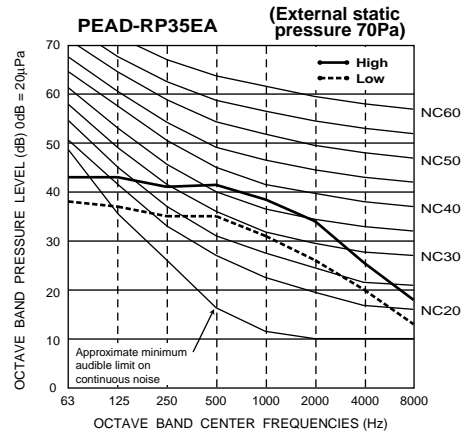
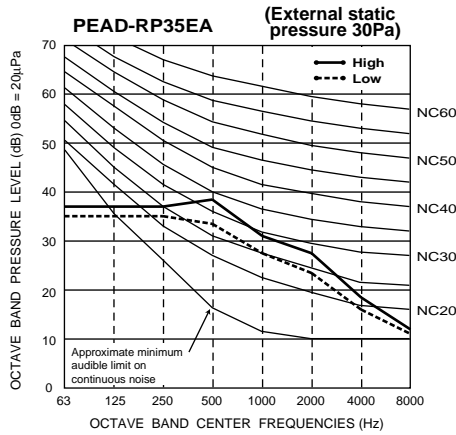

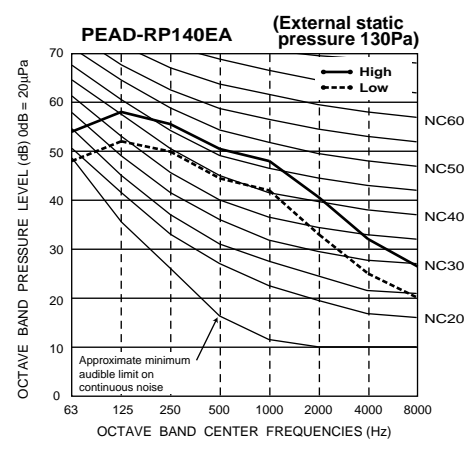
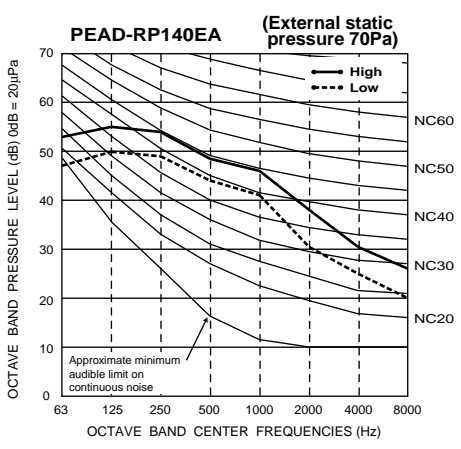
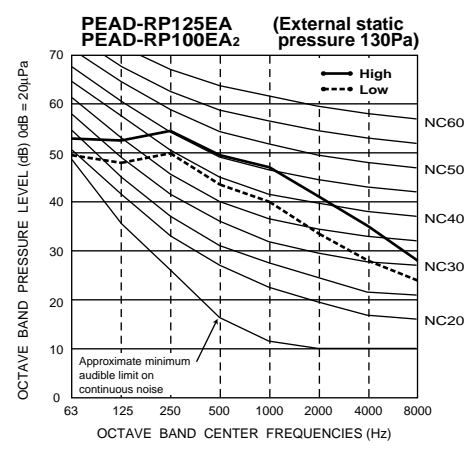
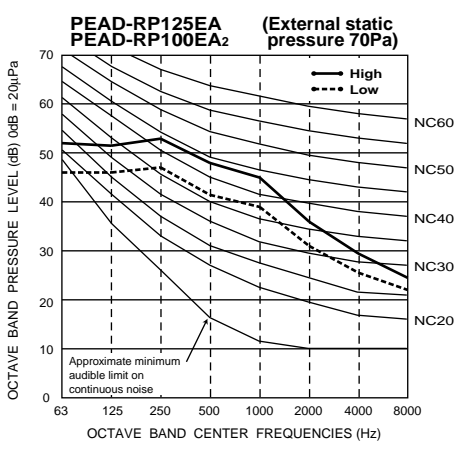
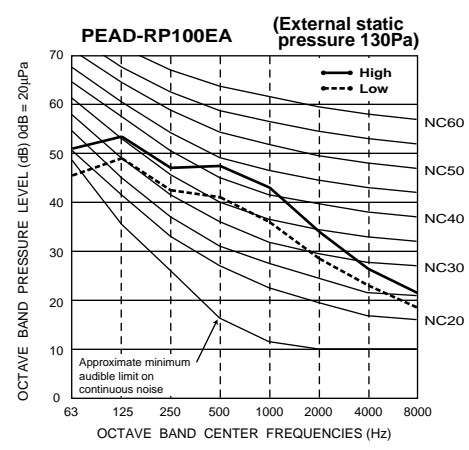
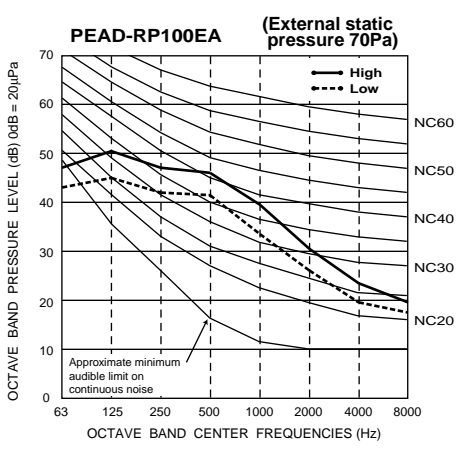
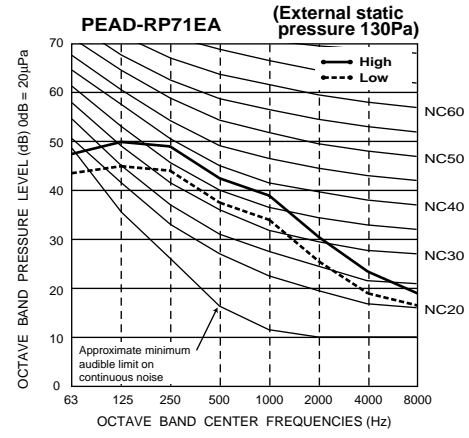
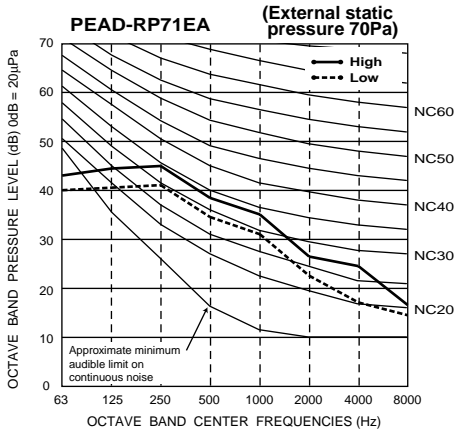

7

OUTLINES & DIMENSIONS

1. INDOOR UNIT

PEAD-RP35, 50, 60EA, RP35EA2

Model	A	B	C	D	E	F	G
RP35,50	772	305	-	830	804	R410A Outdoor unit:6.35 * R407C Outdoor unit:9.52	R410A Outdoor unit:12.7 * R407C Outdoor unit:15.88
RP60	1012	280	290	1070	1044	Outdoor unit(MUZ,SUZ):6.35 Other outdoor unit:9.52 *	15.88

* Setting at shipment

- ① Refrigerant piping flare connection (liquid ϕ F copper tube):HP
- ② Refrigerant piping flare connection (gas ϕ G copper tube):LP
- ③ Drain R1(External thread)
- ④ Electrical parts box
- ⑤ Drain Pump (Option)
- ⑥ Drain Pipe (Option)...Flexible joint VP-25(I.D. ϕ 32))Set
- ⑦ Air Filter

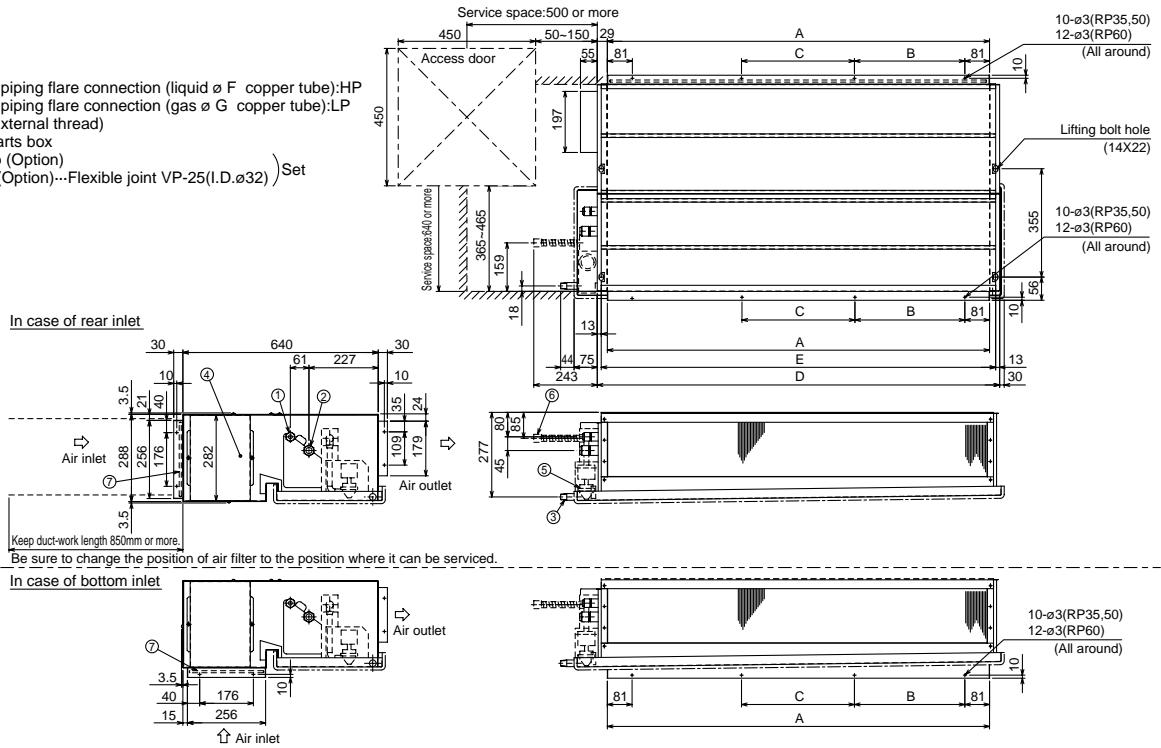

PEAD-RP71, 100, 125, 140EA, RP100EA2

Model	A	B	C	D	E	F
RP71	1012	280	290	1070	1044	15.88
RP100,125	1252	360	370	1310	1284	R410A Outdoor unit:15.88 *
RP140	1552	460	470	1610	1584	R407C Outdoor unit:19.05

* Setting at shipment

- ① Refrigerant piping flare connection (liquid ϕ 9.52 copper tube):HP
- ② Refrigerant piping flare connection (gas ϕ F copper tube):LP
- ③ Drain R1 (External thread)
- ④ Electrical parts box
- ⑤ Drain Pump (Option)
- ⑥ Drain Pipe (Option)...Flexible joint VP25(I.D. ϕ 32))Set
- ⑦ Air Filter

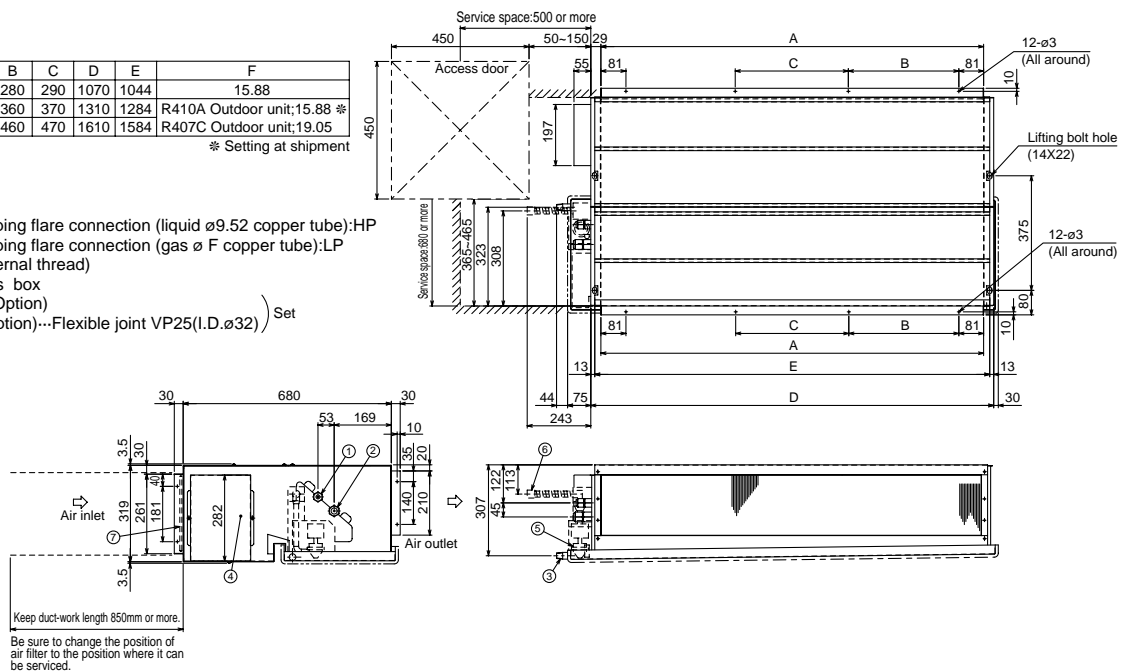

2. REMOTE CONTROLLER

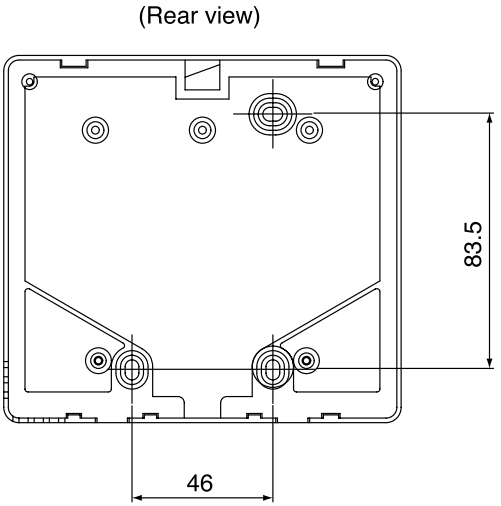
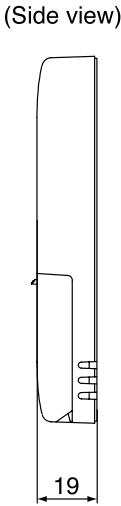
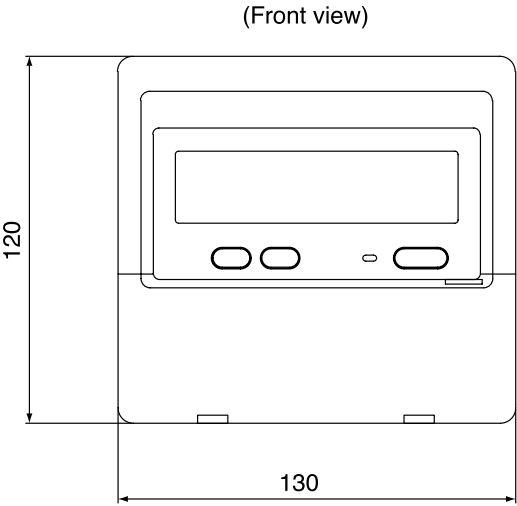

8

WIRING DIAGRAM

PEAD-RP35, 50, 60, 71, 100, 125, 140EA
 PEAD-RP35, 100EA2

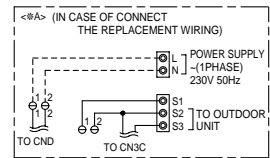
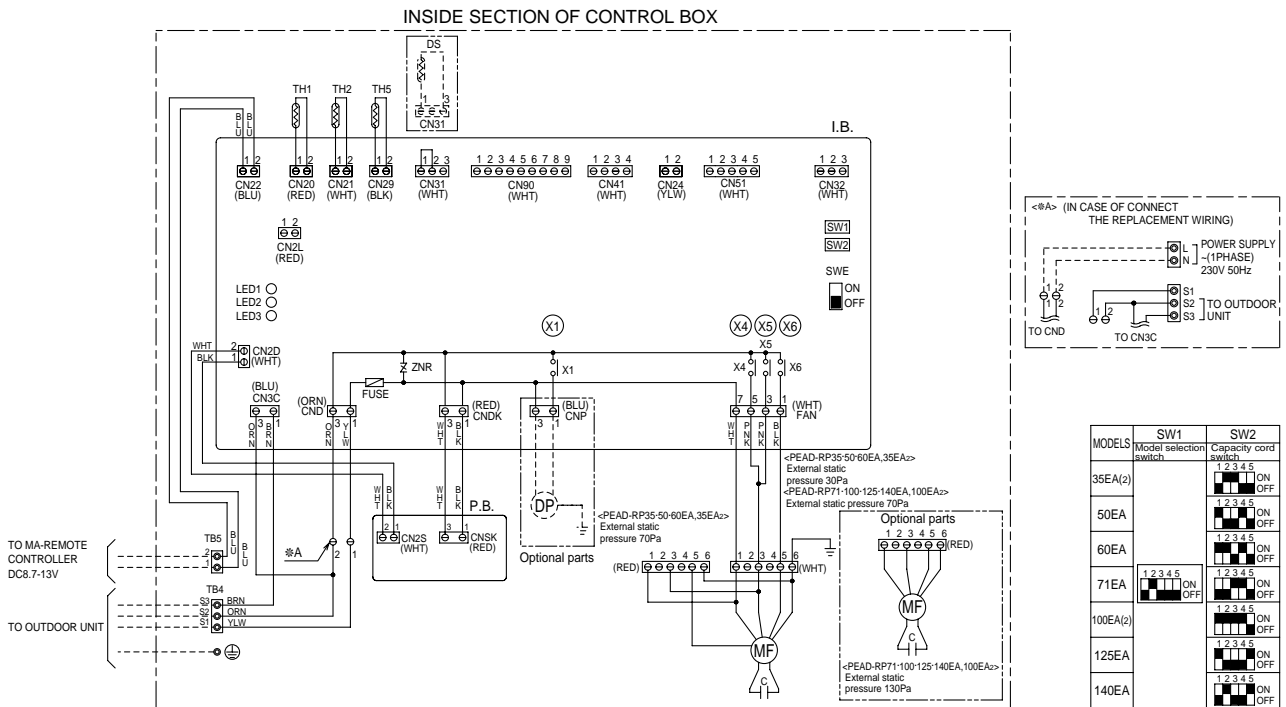

MODELS	SW1 Model selection switch	SW2 Capacity cord switch
35EA(2)	1 2 3 4 5 ON OFF	1 2 3 4 5 ON OFF
50EA	1 2 3 4 5 ON OFF	1 2 3 4 5 ON OFF
60EA	1 2 3 4 5 ON OFF	1 2 3 4 5 ON OFF
71EA	1 2 3 4 5 ON OFF	1 2 3 4 5 ON OFF
100EA(2)	1 2 3 4 5 ON OFF	1 2 3 4 5 ON OFF
125EA	1 2 3 4 5 ON OFF	1 2 3 4 5 ON OFF
140EA	1 2 3 4 5 ON OFF	1 2 3 4 5 ON OFF

SYMBOL	NAME	SYMBOL	NAME	SYMBOL	NAME
I.B.	INDOOR CONTROLLER BOARD	SW2	SWITCH(CAPACITY CORD)	TB4	TERMINAL BLOCK (INDOOR/OUTDOOR CONNECTING LINE)
FUSE	FUSE(T6.3AL250V)	SWE	SWITCH(EMERGENCY OPERATION)	TB5	TERMINAL BLOCK(REMOTE CONTROLLER)
ZNR	VARISTOR	X1	RELAY(DRAIN PUMP)	TH1	INTAKE AIR TEMP. THERMISTOR (0°C/15KΩ,25°C/5.4KΩ DETECT)
CN2L	CONNECTOR(LOSSNAY)	X4	RELAY(FAN MOTOR)	TH2	PIPE TEMP. THERMISTOR/LIQUID (0°C/15KΩ,25°C/5.4KΩ DETECT)
CN24	CONNECTOR(HEATER)	X5	RELAY(FAN MOTOR)	TH5	COND./EVA. TEMP. THERMISTOR (0°C/15KΩ,25°C/5.4KΩ DETECT)
CN32	CONNECTOR(REMOTE SWITCH)	X6	RELAY(FAN MOTOR)		
CN41	CONNECTOR(HA TERMINAL-A)	P.B.	INDOOR POWER BOARD		
CN51	CONNECTOR(CENTRALLY CONTROL)	DP	DRAIN PUMP		
CN90	CONNECTOR(WIRELESS)	DS	DRAIN SENSOR		
LED1	POWER SUPPLY(I.B.)	C	CAPACITOR(FAN MOTOR)		
LED2	POWER SUPPLY(REMOTE CONTROLLER)	MF	FAN MOTOR		
LED3	TRANSMISSION(INDOOR-OUTDOOR)				
SW1	SWITCH(MODEL SELECTION)				

NOTE 1. SINCE THE OUTDOOR SIDE ELECTRIC WIRING MAY CHANGE BE SURE TO CHECK THE OUTDOOR UNIT ELECTRIC WIRING FOR SERVICING.
 2. INDOOR AND OUTDOOR CONNECTING WIRES ARE MADE WITH POLARITIES. MAKE WIRING MATCHING TERMINAL NUMBERS(S1,S2,S3).
 3. SYMBOLS USED IN WIRING DIAGRAM ABOVE ARE, CONNECTOR, TERMINAL.
 4. THE WIRING BETWEEN MA-REMOTE CONTROLLER AND TB5 IS INCLUDED IN THE PACKAGE.

9

REFRIGERANT SYSTEM DIAGRAM

PEAD-RP35, 50, 60, 71, 100, 125, 140EA

PEAD-RP35, 100EA2

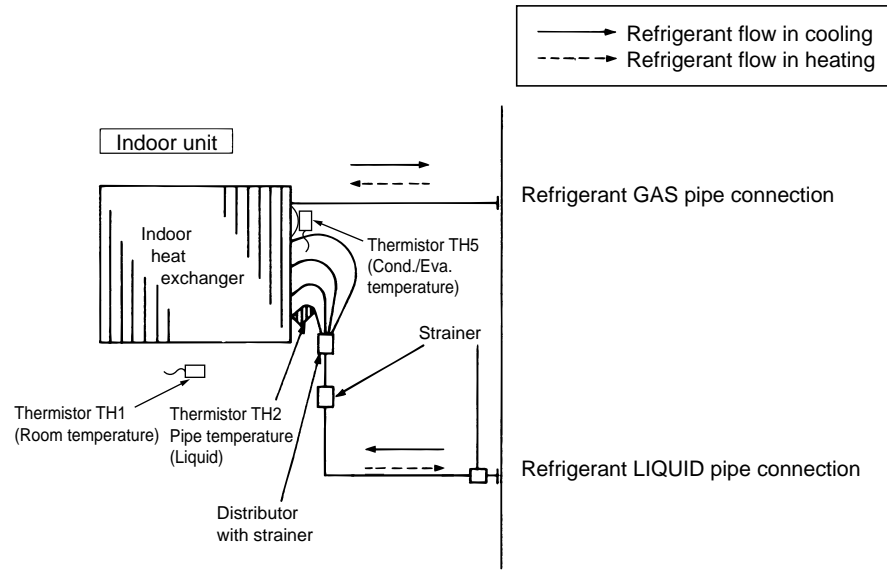

10-1. TROUBLESHOOTING**<Error code display by self-diagnosis and actions to be taken for service (summary)>**

Present and past error codes are logged and displayed on the wired remote controller or controller board of outdoor unit.

Actions to be taken for service and the inferior phenomenon reoccurrence at field are summarized in the table below. Check the contents below before investigating details.

Unit conditions at service	Error code	Actions to be taken for service (summary)
The inferior phenomenon is reoccurring.	Displayed	Judge what is wrong and take a corrective action according to "SELF-DIAGNOSIS ACTION TABLE" (10-2).
	Not displayed	Identify the cause of the inferior phenomenon and take a corrective action according to "TROUBLESHOOTING BY INFERIOR PHENOMENA " (10-3).
The inferior phenomenon is not reoccurring.	Logged	<ul style="list-style-type: none"> ①Consider the temporary defects such as the work of protection devices in the refrigerant circuit including compressor, poor connection of wiring, noise and etc. Re-check the symptom, and check the installation environment, refrigerant amount, weather when the inferior phenomenon occurred, and wiring related. ②Reset error code logs and restart the unit after finishing service. ③There is no abnormality in electrical components, controller boards, and remote controller.
	Not logged	<ul style="list-style-type: none"> ①Recheck the abnormal symptom. ②Identify the cause of the inferior phenomenon and take a corrective action according to "TROUBLESHOOTING BY INFERIOR PHENOMENA " (10-3). ③Continue to operate unit for the time being if the cause is not ascertained. ④There is no abnormality in electrical components, controller boards, remote controller etc.

Note: Refer to the manual of outdoor unit for the details of display such as F, U, and other E.

10-2. SELF-DIAGNOSIS ACTION TABLE

Error Code	Meaning of error code and detection method	Cause	Countermeasure
P1	<p>Abnormality of room temperature thermistor (TH1)</p> <p>① The unit is in three-minute resume prevention mode if short/open of thermistor is detected. Abnormal if the unit does not reset normally after three minutes. (The unit returns to normal operation, if it has normally reset.)</p> <p>② Constantly detected during cooling, drying, and heating operation. Short: 90°C or more Open: -40°C or less</p>	<p>① Defective thermistor characteristics.</p> <p>② Contact failure of connector (CN20) on the indoor controller board. (Insert failure)</p> <p>③ Breaking of wire or contact failure of thermistor wiring.</p> <p>④ Defective indoor controller board.</p>	<p>①—③ Check resistance value of thermistor. 0°C15.0kΩ 10°C9.6kΩ 20°C6.3kΩ 30°C4.3kΩ 40°C3.0kΩ If you put force on (draw or bend) the lead wire with measuring resistance value of thermistor breaking of wire or contact failure can be detected.</p> <p>② Check contact failure of connector (CN20) on the indoor controller board. Refer to 10-6. Turn the power on again and check restart after inserting connector again.</p> <p>④ Check room temperature display on remote controller. Replace indoor controller board if there is abnormal difference with actual room temperature.</p> <p>Turn the power off, and on again to operate after check.</p>
P2	<p>Abnormality of pipe temperature thermistor/Liquid (TH2)</p> <p>① The unit is in three-minute resume prevention mode if short/open of thermistor is detected. Abnormal if the unit does not reset normally after three minutes. (The unit returns to normal operation, if it has normally reset.)</p> <p>② Constantly detected during cooling, drying, and heating (except defrosting) operation. Short: 90°C or more Open: -40°C or less</p>	<p>① Defective thermistor characteristics.</p> <p>② Contact failure of connector (CN21) on the indoor controller board. (Insert failure)</p> <p>③ Breaking of wire or contact failure of thermistor wiring.</p> <p>④ Defective refrigerant circuit is causing thermistor temperature of 90°C or more or -40°C or less.</p> <p>⑤ Defective indoor controller board.</p>	<p>①—③ Check resistance value of thermistor. For characteristics, refer to (P1) above.</p> <p>② Check contact failure of connector (CN21) on the indoor controller board. Refer to 10-6. Turn the power on and check restart after inserting connector again.</p> <p>④ Check pipe <liquid> temperature with remote controller in test run mode. If pipe <liquid> temperature is exclusively low (in cooling mode) or high (in heating mode), refrigerant circuit may have defective.</p> <p>⑤ Check pipe <liquid> temperature with remote controller in test run mode. If there is exclusive difference with actual pipe <liquid> temperature, replace indoor controller board.</p> <p>Turn the power off, and on again to operate after check.</p>
P4	<p>Abnormality of drain sensor (DS)</p> <p>① Suspensive abnormality, if short/open of thermistor is detected for 30 seconds continuously. Turn off compressor and indoor fan.</p> <p>② Short/open is detected for 30 seconds continuously during suspensive abnormality. (The unit returns to normal operation, if it has normally reset.)</p> <p>③ Detect the following condition.</p> <ul style="list-style-type: none"> • During cooling and drying operation. • In case that pipe <liquid> temperature - room temperature <-10deg (Except defrosting) • When pipe <liquid> temperature or room temperature is short/open temperature. • During drain pump operation. 	<p>① Defective thermistor characteristics</p> <p>② Contact failure of connector (CN31) on the indoor controller board. (Insert failure).</p> <p>③ Breaking of wire or contact failure of drain sensor wiring.</p> <p>④ Defective indoor controller board.</p>	<p>①—③ Check resistance value of thermistor. 0°C6.0kΩ 10°C3.9kΩ 20°C2.6kΩ 30°C1.8kΩ 40°C1.3kΩ</p> <p>② Check contact failure of connector (CN31) on the indoor controller board. Refer to 10-6. Turn the power on again and check restart after inserting connector again.</p> <p>④ Replace indoor controller board if drain pump operates with the line of drain sensor connector CN31-① and ② is short-circuited, and abnormality reappears.</p> <p>Turn the power off, and on again to operate after check.</p>
P5	<p>Malfunction of drain pump (DP)</p> <p>① Suspensive abnormality, if thermistor of drain sensor is let heat itself and temperature rises slightly. Turn off compressor and indoor fan.</p> <p>② Drain pump is abnormal if the condition above is detected during suspensive abnormality.</p> <p>③ Constantly detected during drain pump operation.</p>	<p>① Malfunction of drain pump</p> <p>② Defective drain Clogged drain pump Clogged drain pipe</p> <p>③ Attached drop of water at the drain sensor</p> <ul style="list-style-type: none"> • Drops of drain trickles from lead wire. • Clogged filter is causing wave of drain. <p>④ Defective indoor controller board.</p>	<p>① Check if drain-up machine works.</p> <p>② Check drain function.</p> <p>③ Check the setting of lead wire of drain sensor and check clogs of the filter.</p> <p>④ Replace indoor controller board if drain pump operates with the line of drain sensor connector CN31-① and ② is short-circuited and abnormality reappears. Refer to 10-6.</p> <p>Turn the power off, and on again to operate after check.</p>

Error Code	Meaning of error code and detection method	Cause	Countermeasure
P6	<p>Freezing/overheating protection is working</p> <p>① Freezing protection (Cooling mode) The unit is in six-minute resume prevention mode if pipe <liquid or condenser/evaporator> temperature stays under -15°C for three minutes, three minutes after the compressor started. Abnormal if it stays under -15°C for three minutes again within 16 minutes after six-minute resume prevention mode. <Frost prevention mode> If pipe <liquid or condenser-evaporator> temperature is 2°C or below when 16 minutes has passed after compressor starts operating, unit will start operating in frost prevention mode which stops compressor operation. After that, when pipe <liquid or condenser/evaporator> temperature stays 10°C or more for 3 minutes, frost prevention mode will be released and compressor will restart its operation.</p> <p>② Overheating protection (Heating mode) The units is in six-minute resume prevention mode if pipe <condenser / evaporator> temperature is detected as over 70°C after the compressor started. Abnormal if the temperature of over 70°C is detected again within 10 minutes after six-minute resume prevention mode.</p>	<p>(Cooling or drying mode)</p> <p>① Clogged filter (reduced airflow) ② Short cycle of air path ③ Low-load (low temperature) operation beyond the tolerance range ④ Defective indoor fan motor • Fan motor is defective. • Indoor controller board is defective.</p> <p>⑤ Defective outdoor fan control ⑥ Overcharge of refrigerant ⑦ Defective refrigerant circuit (clogs)</p> <p>(Heating mode)</p> <p>① Clogged filter (reduced airflow) ② Short cycle of air path ③ Over-load (high temperature) operation beyond the tolerance range ④ Defective indoor fan motor • Fan motor is defective. • Indoor controller board is defective.</p> <p>⑤ Defective outdoor fan control ⑥ Overcharge of refrigerant ⑦ Defective refrigerant circuit (clogs) ⑧ Bypass circuit of outdoor unit is defective.</p>	<p>(Cooling or drying mode)</p> <p>① Check clogs of the filter. ② Remove shields.</p> <p>④ Measure the resistance of fan motor's winding. Measure the output voltage of fan's connector (FAN) on the indoor controller board. *The indoor controller board should be normal when voltage of AC 220~240V is detected while fan motor is connected. Refer to 10-6. ⑤ Check outdoor fan motor. ⑥⑦ Check operating condition of refrigerant circuit.</p> <p>(Heating mode)</p> <p>① Check clogs of the filter. ② Remove shields.</p> <p>④ Measure the resistance of fan motor's winding. Measure the output voltage of fan's connector (FAN) on the indoor controller board. *The indoor controller board should be normal when voltage of AC 220~240V is detected while fan motor is connected. Refer to 10-6. ⑤ Check outdoor fan motor. ⑥~⑧ Check operating condition of refrigerant circuit.</p>
P8	<p>Abnormality of pipe temperature <Cooling mode> Detected as abnormal when the pipe temperature is not in the cooling range 3 minutes later of compressor start and 6 minutes later of the liquid or condenser/evaporator pipe is out of cooling range. Note 1) It takes at least 9 min. to detect. Note 2) Abnormality P8 is not detected in drying mode. Cooling range : -3 deg \geq (TH-TH1) TH: Lower temperature between: liquid pipe temperature (TH2) and condenser/evaporator temperature (TH5) TH1: Intake temperature</p> <p><Heating mode> When 10 seconds have passed after the compressor starts operation and the hot adjustment mode has finished, the unit is detected as abnormal when condenser/evaporator pipe temperature is not in heating range within 20 minutes.</p> <p>Note 3) It takes at least 27 minutes to detect abnormality. Note 4) It excludes the period of defrosting (Detection restarts when defrosting mode is over) Heating range : 3 deg \leq (TH5-TH1)</p>	<p>① Slight temperature difference between indoor room temperature and pipe <liquid or condenser / evaporator> temperature thermistor • Shortage of refrigerant • Disconnected holder of pipe <liquid or condenser / evaporator> thermistor • Defective refrigerant circuit</p> <p>② Converse connection of extension pipe (on plural units connection) ③ Converse wiring of indoor/outdoor unit connecting wire (on plural units connection) ④ Defective detection of indoor room temperature and pipe <condenser / evaporator> temperature thermistor ⑤ Stop valve is not opened completely.</p>	<p>①~④ Check pipe <liquid or condenser / evaporator> temperature with room temperature display on remote controller and outdoor controller circuit board. Pipe <liquid or condenser / evaporator> temperature display is indicated by setting SW2 of outdoor controller circuit board as follows.</p> <p>(Conduct temperature check with outdoor controller circuit board after connecting 'A-Control Service Tool(PAC-SK52ST)')</p> <p>②③ Check converse connection of extension pipe or converse wiring of indoor/outdoor unit connecting wire.</p>

Error Code	Meaning of error code and detection method	Cause	Countermeasure
Pg	<p>Abnormality of pipe temperature thermistor / Condenser-Evaporator (TH5)</p> <p>① The unit is in three-minute resume protection mode if short/open of thermistor is detected. Abnormal if the unit does not get back to normal within three minutes. (The unit returns to normal operation, if it has normally reset.)</p> <p>② Constantly detected during cooling, drying, and heating operation (except defrosting) Short: 90°C or more Open: -40°C or less</p>	<p>① Defective thermistor characteristics</p> <p>② Contact failure of connector (CN29) on the indoor controller board. (Insert failure)</p> <p>③ Breaking of wire or contact failure of thermistor wiring.</p> <p>④ Temperature of thermistor is 90°C or more or -40°C or less caused by defective refrigerant circuit.</p> <p>⑤ Defective indoor controller board.</p>	<p>①-③ Check resistance value of thermistor. For characteristics, refer to (P1) above.</p> <p>② Check contact failure of connector (CN29) on the indoor controller board. Refer to 10-6. Turn the power on and check restart after inserting connector again.</p> <p>④ Operate in test run mode and check pipe <condenser / evaporator> temperature with outdoor controller circuit board. If pipe <condenser / evaporator> temperature is exclusively low (in cooling mode) or high (in heating mode), refrigerant circuit may have defective.</p> <p>⑤ Operate in test run mode and check pipe <condenser / evaporator> temperature with outdoor control circuit board. If there is exclusive difference with actual pipe <condenser / evaporator> temperature replace indoor controller board. There is no abnormality if none of above comes within the unit. Turn the power off and on again to operate.</p> <p>(In case of checking pipe temperature with outdoor controller circuit board, be sure to connect A-control service tool (PAC-SK52ST).)</p>
E0 or E4	<p>Remote controller transmission error(E0)/signal receiving error(E4)</p> <p>① Abnormal if main or sub remote controller can not receive normally any transmission from indoor unit of refrigerant address "0" for three minutes. (Error code : E0)</p> <p>② Abnormal if sub remote controller could not receive for any signal for two minutes. (Error code: E0)</p> <p>① Abnormal if indoor controller board can not receive normally any data from remote controller board or from other indoor controller board for three minutes. (Error code: E4)</p> <p>② Indoor controller board cannot receive any signal from remote controller for two minutes. (Error code: E4)</p>	<p>① Contact failure at transmission wire of remote controller</p> <p>② All remote controllers are set as "sub" remote controller. In this case, E0 is displayed on remote controller, and E4 is displayed at LED (LED1, LED2) on the outdoor controller circuit board.</p> <p>③ Mis-wiring of remote controller.</p> <p>④ Defective transmitting receiving circuit of remote controller</p> <p>⑤ Defective transmitting receiving circuit of indoor controller board of refrigerant address "0".</p> <p>⑥ Noise has entered into the transmission wire of remote controller.</p>	<p>① Check disconnection or looseness of indoor unit or transmission wire of remote controller.</p> <p>② Set one of the remote controllers "main". If there is no problem with the action above.</p> <p>③ Check wiring of remote controller.</p> <ul style="list-style-type: none"> • Total wiring length: max.500m (Do not use cablex 3 or more) • The number of connecting indoor units: max.16units • The number of connecting remote controller: max.2units <p>When it is not the above-mentioned problem of ①~③</p> <p>④ Diagnose remote controllers.</p> <p>a) When "RC OK" is displayed, Remote controllers have no problem. Put the power off, and on again to check. If abnormality generates again, replace indoor controller board.</p> <p>b) When "RC NG" is displayed, Replace remote controller.</p> <p>c) When "RC E3" is displayed,</p> <p>d) When "ERC 00-06" is displayed, [c),d)→Noise may be causing abnormality.]</p> <p>* If the unit is not normal after replacing indoor controller board in group control, indoor controller board of address "0" may be abnormal.</p>
E3 or E5	<p>Remote controller transmission error(E3)/signal receiving error(E5)</p> <p>① Abnormal if remote controller could not find blank of transmission path for six seconds and could not transmit. (Error code: E3)</p> <p>② Remote controller receives transmitted data at the same time, compares the data, and when detecting it, judges different data to be abnormal 30 continuous times. (Error code: E3)</p> <p>① Abnormal if indoor controller board could not find blank of transmission path. (Error code: E5)</p> <p>② Indoor controller board receives transmitted data at the same time, compares the data, and when detecting it, judges different data to be abnormal 30 continuous times. (Error code: E5)</p>	<p>① Two remote controller are set as "main." (In case of 2 remote controllers)</p> <p>② Remote controller is connected with two indoor units or more.</p> <p>③ Repetition of refrigerant address.</p> <p>④ Defective transmitting receiving circuit of remote controller.</p> <p>⑤ Defective transmitting receiving circuit of indoor controller board.</p> <p>⑥ Noise has entered into transmission wire of remote controller.</p>	<p>① Set a remote controller to main, and the other to sub.</p> <p>② Remote controller is connected with only one indoor unit.</p> <p>③ The address changes to a separate setting.</p> <p>④~⑥ Diagnose remote controller.</p> <p>a) When "RC OK" is displayed, remote controllers have no problem. Put the power off, and on again to check. When becoming abnormal again, replace indoor controller board.</p> <p>b) When "RC NG" is displayed, replace remote controller.</p> <p>c) When "RC E3" or "ERC 00-66" is displayed, noise may be causing abnormality.</p>

Error Code	Meaning of error code and detection method	Cause	Countermeasure
E6	Indoor/outdoor unit communication error (Signal receiving error) ① Abnormal if indoor controller board cannot receive any signal normally for six minutes after putting the power on. ② Abnormal if indoor controller board cannot receive any signal normally for three minutes. ③ Consider the unit abnormal under the following condition: When two or more indoor units are connected to one outdoor unit, indoor controller board cannot receive a signal for three minutes from outdoor controller circuit board, a signal which allows outdoor controller circuit board to transmit signals.	① Contact failure, short circuit or, mis-wiring (converse wiring) of indoor/outdoor unit connecting wire ② Defective transmitting receiving circuit of indoor controller board ③ Defective transmitting receiving circuit of indoor controller board ④ Noise has entered into indoor/outdoor unit connecting wire.	* Check LED display on the outdoor control circuit board. (Connect A-control service tool, PAC-SK52ST.) Refer to EA-EC item if LED displays EA-EC. ① Check disconnection or looseness of indoor/outdoor unit connecting wire of indoor unit or outdoor unit. Check all the units in case of twin triple indoor unit system. ②-④ Turn the power off, and on again to check. If abnormality generates again, replace indoor controller board or outdoor controller circuit board. * Other indoor controller board may have defective in case of twin triple indoor unit system.
E7	Indoor/outdoor unit communication error (Transmitting error) Abnormal if "1" receiving is detected 30 times continuously though indoor controller board has transmitted "0".	① Defective transmitting receiving circuit of indoor controller board ② Noise has entered into power supply. ③ Noise has entered into outdoor control wire.	①-③ Turn the power off, and on again to check. If abnormality generates again, replace indoor controller board.
Fb	Abnormality of indoor controller board Abnormal if data cannot be normally read from the nonvolatile memory of the indoor controller board.	① Defective indoor controller board.	① Replace indoor controller board.
E1 or E2	Abnormality of remote controller control board ① Abnormal if data cannot be normally read from the nonvolatile memory of the remote controller control board. (Error code: E1) ② Abnormal if the clock function of remote controller cannot be normally operated. (Error code: E2)	① Defective remote controller.	① Replace remote controller.

10-3. TROUBLESHOOTING BY INFERIOR PHENOMENA

Note: Refer to the manual of outdoor unit for the detail of remote controller.

Phenomena	Cause	Countermeasure
<p>(1)LED2 on indoor controller board is off.</p>	<ul style="list-style-type: none"> • When LED1 on indoor controller board is also off. ① Power supply of rated voltage is not supplied to outdoor unit. ② Defective outdoor controller circuit board. ③ Power supply of 220~240V is not supplied to indoor unit. ④ Defective indoor power board. ⑤ Defective indoor controller board. <p>(For the separate indoor/outdoor unit power supply system)</p> <ul style="list-style-type: none"> ① Power supply of 220~240V AC is not supplied to indoor unit. ② The connectors of the optional replacement kit are not used. ③ Defective indoor controller board. ④ Defective indoor power board. 	<ul style="list-style-type: none"> ① Check the voltage of outdoor power supply terminal block (L, N) or (L₃, N). <ul style="list-style-type: none"> • When AC 220~240V is not detected. Check the power wiring to outdoor unit and the breaker. • When AC 220~240V is detected. —Check ② (below). ② Check the voltage between outdoor terminal block S1 and S2. <ul style="list-style-type: none"> • When AC 220~240V is not detected. Check the fuse on outdoor controller circuit board. • Check the wiring connection. • When AC 220~240V is detected. —Check ③ (below). ③ Check the voltage between indoor terminal block S1 and S2. <ul style="list-style-type: none"> • When AC 220~240V is not detected. Check indoor/outdoor unit connecting wire for mis-wiring. • When AC 220~240V is detected. —Check ④ (below). ④ Check voltage output from CN2S on indoor power board (DC13.1V). Refer to 10-6-1. <ul style="list-style-type: none"> • When no voltage is output. Check the wiring connection. • When output voltage is between DC12.5V and DC13.7V. —Check ⑤ (below). ⑤ Check the wiring connection between indoor controller board and indoor power board. Check the fuse on indoor controller board. If no problems are found, indoor controller board is defective. <ul style="list-style-type: none"> ① Check the voltage of indoor power supply terminal block (L,N). <ul style="list-style-type: none"> • When AC220~240V is not detected. Check the power supply wiring. • When AC220~240V is detected. -Check ② (below). ② Check that there is no problem in the method of connecting the connectors. <ul style="list-style-type: none"> • When there are problems in the method of connecting the connectors. Connect the connector correctly referring to installation manual of an optional kit. • When there is no problem in the method of connecting the connectors. -Check ③ (below). ③ Check voltage output from CNDK on indoor controller board. <ul style="list-style-type: none"> • When AC220~240V is not detected. Check the fuse on indoor controller board. • Check the wiring connection between indoor power supply terminal block and CND on indoor controller board. • When AC220~240V is detected. -Check ④ (below). ④ Check voltage output from CN2S on indoor power board. <ul style="list-style-type: none"> • When no voltage output. Check the wiring connection between CNDK on indoor controller board and CNSK on indoor power board. If no problem are found, indoor power board is defective. • When DC12.5~13.7V is detected. Check the wiring connection between CN2S on indoor power board and CN2D on indoor power board. If no problem are found, indoor controller board is defective.
	<ul style="list-style-type: none"> • When LED1 on indoor controller board is lit. ① Mis-setting of refrigerant address for outdoor unit (There is no unit corresponding to refrigerant address "0".) 	<ul style="list-style-type: none"> ① Reconfirm the setting of refrigerant address for outdoor unit Set the refrigerant address to "0". (For grouping control system under which 2 or more outdoor units are connected, set one of the units to "0".) Set refrigerant address using SW1 (3-6) on outdoor controller circuit board.

Note: Refer to the manual of outdoor unit for the detail of remote controller.

Phenomena	Cause	Countermeasure
(2)LED2 on indoor controller board is blinking.	<ul style="list-style-type: none"> • When LED1 on indoor controller board is also blinking. Connection failure of indoor/outdoor unit connecting wire • When LED1 is lit. <ol style="list-style-type: none"> ① Mis-wiring of remote controller wires Under twin triple indoor unit system, 2 or more indoor units are wired together. ② Refrigerant address for outdoor unit is wrong or not set. Under grouping control system, there are some units whose refrigerant address is 0. ③ Short-cut of remote controller wires ④ Defective remote controller 	<p>Check indoor/outdoor unit connecting wire for connection failure.</p> <ol style="list-style-type: none"> ① Check the connection of remote controller wires in case of twin triple indoor unit system. When 2 or more indoor units are wired in one refrigerant system, connect remote controller wires to one of those units. ② Check the setting of refrigerant address in case of grouping control system. If there are some units whose refrigerant addresses are 0 in one group, set one of the units to 0 using SW1 (3-6) on outdoor controller circuit board. ③④ Remove remote controller wires and check LED2 on indoor controller board. <ul style="list-style-type: none"> • When LED2 is blinking, check the short-cut of remote controller wires. • When LED2 is lit, connect remote controller wires again and: if LED2 is blinking, remote controller is defective; if LED2 is lit, connection failure of remote controller terminal block etc. has returned to normal.
(3)Upward/downward vane performance failure	<ol style="list-style-type: none"> ① The vane is not downward during defrosting and heat preparation and when the thermostat is OFF in HEAT mode. (Working of COOL protection function) ② Vane motor does not rotate. <ul style="list-style-type: none"> • Defective vane motor • Breaking of wire or connection failure of connector • Up/down vane setting is "No vanes". ③ Upward/downward vane does not work. <ul style="list-style-type: none"> • The vane is set to fixed position. 	<ol style="list-style-type: none"> ① Normal operation (The vane is set to horizontal regardless of remote control.) ② Check ② (left). <ul style="list-style-type: none"> • Check the vane motor. (Refer to "How to check the parts".) • Check for breaking of wire or connection failure of connector. • Check "Up/down vane setting". (Unit function selection by remote controller). ③ Normal operation (Each connector on vane motor side is disconnected.)
(4)Receiver for wireless remote controller	<ol style="list-style-type: none"> ① Weak batteries of wireless remote controller. ② Contact failure of connector (CNB) on wireless remote controller board. (Insert failure) ③ Contact failure of connector (CN90) on indoor controller board.(Insert failure) ④ Contact failure of connector between wireless remote controller board and indoor controller board. 	<ol style="list-style-type: none"> ① Replace batteries of wireless remote controller. ②~④ Check contact failure of each connector. If no problems are found of connector, replace indoor controller board. When the same trouble occurs even if indoor controller board is replaced, replace wireless remote controller board.

10-4. When wired remote controller or indoor unit micro computer troubles

1. If there is not any other wrong when trouble occurs, emergency operation starts as the indoor controller board switch (SWE) is set to ON.

During the emergency operation the indoor unit is as follows;

- (1) Indoor fan high speed operation (2) Drain-up machine operation

2. When emergency operating for COOL or HEAT, setting of the switch (SWE) in the indoor controller board and outdoor unit emergency operation are necessary.

3. Check items and notices as the emergency operation

(1) Emergency operation cannot be used as follows;

- When the outdoor unit is something wrong.
- When the indoor fan is something wrong.
- When drain over flow protected operation is detected during self-diagnosis. (Error code : P5)

(2) Emergency operation will be serial operation by the power supply ON/OFF.

ON/OFF or temperature, etc. adjustment is not operated by the remote controller.

(3) Do not operate for a long time as cold air is blown when the outdoor unit starts defrosting operation during heat emergency operation.

(4) Cool emergency operation must be within 10 hours at most. It may cause heat exchanger frosting in the indoor unit.

(5) After completing the emergency operation, return the switch setting, etc. in former state.

(6) Since vane does not work at emergency operation, position the vane manually and slowly.

10-5. HOW TO CHECK THE PARTS

Parts name	Check points				
Room temperature thermistor (TH1)	Disconnect the connector then measure the resistance using a tester. (Surrounding temperature 10°C ~30°C)				
Pipe temperature thermistor (TH2)					
Condenser/Evaporator temperature thermistor (TH5)					
	<table border="1"> <thead> <tr> <th>Normal</th> <th>Abnormal</th> </tr> </thead> <tbody> <tr> <td>4.3kΩ~9.6kΩ</td> <td>Open or short</td> </tr> </tbody> </table> (Refer to the thermistor)	Normal	Abnormal	4.3kΩ~9.6kΩ	Open or short
Normal	Abnormal				
4.3kΩ~9.6kΩ	Open or short				

<Thermistor Characteristic graph>

Thermistor for lower temperature

Room temperature thermistor(TH1)
 Pipe temperature thermistor(TH2)
 Condenser/evaporator temperature thermistor(TH5)

Thermistor $R_0=15k\Omega \pm 3\%$

Fixed number of $B=3480k\Omega \pm 2\%$

$$R_t = 15 \exp \left\{ 3480 \left(\frac{1}{273+t} - \frac{1}{273} \right) \right\}$$

0°C	15kΩ
10°C	9.6kΩ
20°C	6.3kΩ
25°C	5.2kΩ
30°C	4.3kΩ
40°C	3.0kΩ

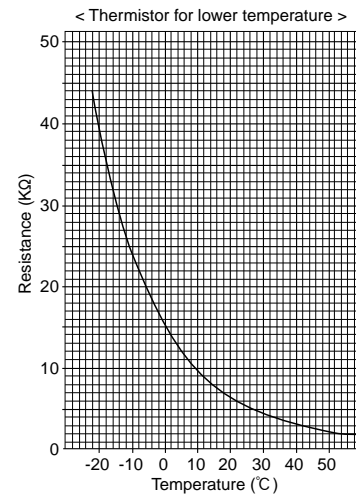

10-6. TEST POINT DIAGRAM

10-6-1. Power board

PEAD-RP35EA(2), PEAD-RP50EA, PEAD-RP60EA,
PEAD-RP71EA, PEAD-RP100EA(2), PEAD-RP125EA,
PEAD-RP140EA

CN2S

Connect to the indoor controller board (CN2D)
Between ① to ③ 12.6-13.7V DC (Pin① (+))

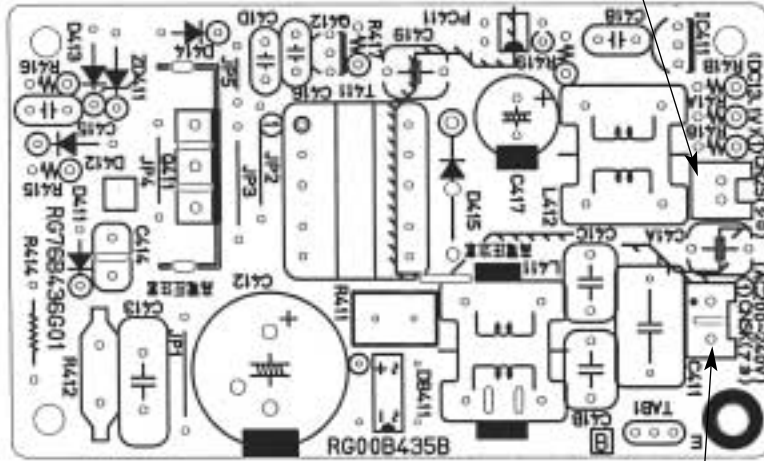

CNSK

Connect to the indoor controller board
(CNDK)
Between ① to ③ 220-240V AC

10-6-2. Indoor controller board
PEAD-RP35EA(2), PEAD-RP50EA, PEAD-RP60EA,
PEAD-RP71EA, PEAD-RP100EA(2), PEAD-RP125EA,
PEAD-RP140EA

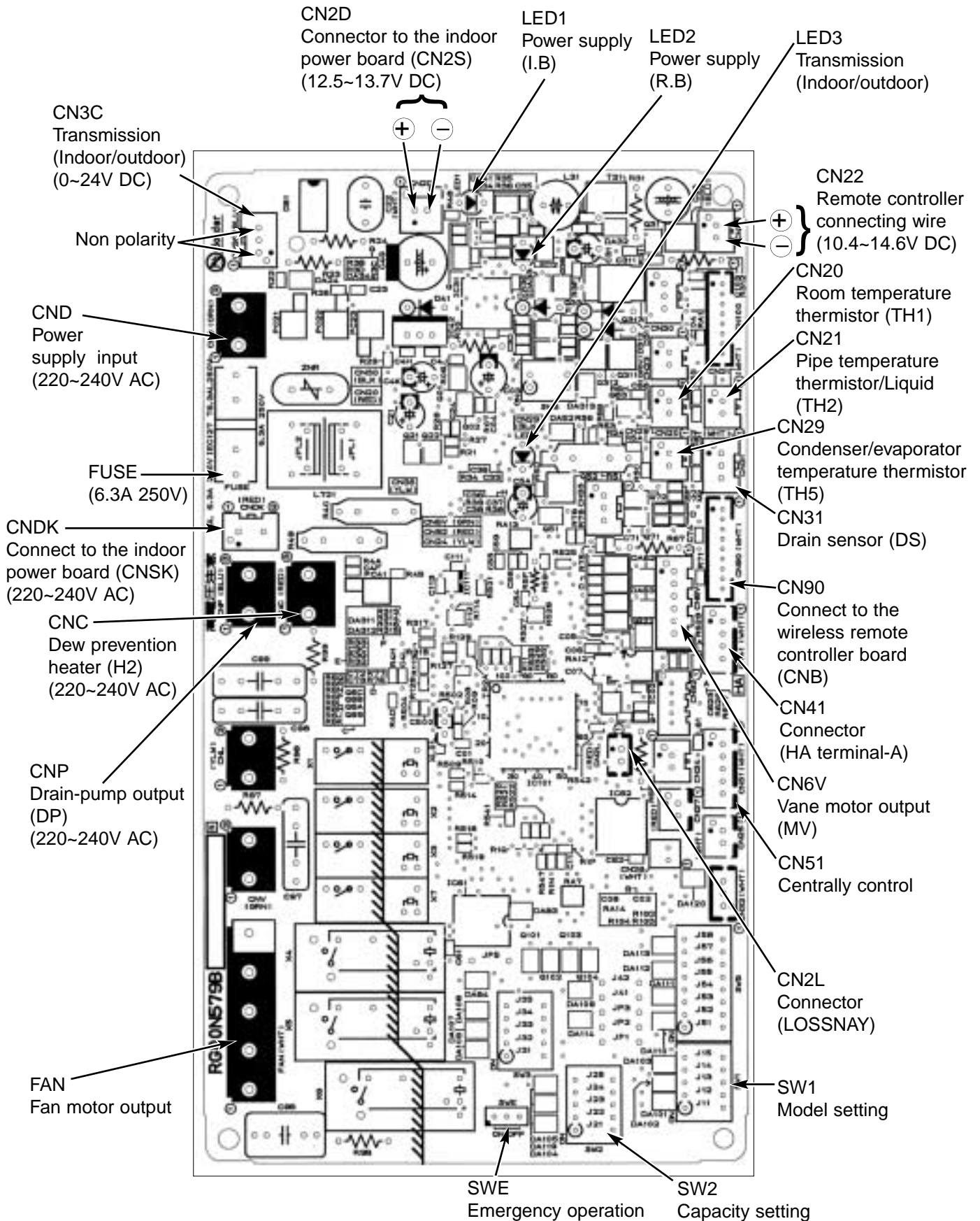

10-7. FUNCTIONS OF DIP SWITCH AND JUMPER WIRE

Each function is controlled by the dip switch and the jumper wire on control p.c. board.

SW1 and SW2 are equipped only for service parts.

Model setting and capacity setting are memorized in the nonvolatile memory of the control p.c. board of the unit.

(Marks in the table below) Jumper wire (○ : Short × : Open)











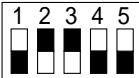
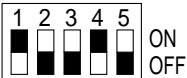
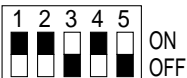

Jumper wire	Functions	Setting by the dip switch and jumper wire	Remarks																	
SW1	Model settings	For service board 																		
SW2	Capacity settings	<table border="1"> <thead> <tr> <th>MODELS</th> <th>Service board</th> </tr> </thead> <tbody> <tr> <td>PEAD-RP35EA(2)</td> <td></td> </tr> <tr> <td>PEAD-RP50EA</td> <td></td> </tr> <tr> <td>PEAD-RP60EA</td> <td></td> </tr> <tr> <td>PEAD-RP71EA</td> <td></td> </tr> <tr> <td>PEAD-RP100EA(2)</td> <td></td> </tr> <tr> <td>PEAD-RP125EA</td> <td></td> </tr> <tr> <td>PEAD-RP140EA</td> <td></td> </tr> </tbody> </table>	MODELS	Service board	PEAD-RP35EA(2)		PEAD-RP50EA		PEAD-RP60EA		PEAD-RP71EA		PEAD-RP100EA(2)		PEAD-RP125EA		PEAD-RP140EA			
MODELS	Service board																			
PEAD-RP35EA(2)																				
PEAD-RP50EA																				
PEAD-RP60EA																				
PEAD-RP71EA																				
PEAD-RP100EA(2)																				
PEAD-RP125EA																				
PEAD-RP140EA																				
J41 J42	Pair number setting with wireless remote controller	<table border="1"> <thead> <tr> <th rowspan="2">Wireless remote controller setting</th> <th colspan="2">Control PCB setting</th> </tr> <tr> <th>J41</th> <th>J42</th> </tr> </thead> <tbody> <tr> <td>0</td> <td>○</td> <td>○</td> </tr> <tr> <td>1</td> <td>×</td> <td>○</td> </tr> <tr> <td>2</td> <td>○</td> <td>×</td> </tr> <tr> <td>3 ~ 9</td> <td>×</td> <td>×</td> </tr> </tbody> </table>	Wireless remote controller setting	Control PCB setting		J41	J42	0	○	○	1	×	○	2	○	×	3 ~ 9	×	×	<p><Settings at time of factory shipment> Wireless remote controller: 0 Control PCB: ○ (for both J41 and J42) Four pair number settings are supported. The pair number settings of the wireless remote controller and indoor control PCB (J41/J42) are given in the table on the left. ('×' in the table indicates the jumper line is disconnected.)</p>
Wireless remote controller setting	Control PCB setting																			
	J41	J42																		
0	○	○																		
1	×	○																		
2	○	×																		
3 ~ 9	×	×																		
JP1	Unit type setting	<table border="1"> <thead> <tr> <th>Model</th> <th>JP1</th> </tr> </thead> <tbody> <tr> <td>Without TH5</td> <td>○</td> </tr> <tr> <td>With TH5</td> <td>×</td> </tr> </tbody> </table>	Model	JP1	Without TH5	○	With TH5	×	There is no jumper (JP1) because these models have the cond./eva. temperature thermistor (TH5).											
Model	JP1																			
Without TH5	○																			
With TH5	×																			
JP3	Indoor controller board type setting	<table border="1"> <thead> <tr> <th>Indoor controller board type</th> <th>JP3</th> </tr> </thead> <tbody> <tr> <td>Factory shipment</td> <td>×</td> </tr> <tr> <td>Service parts</td> <td>○</td> </tr> </tbody> </table>	Indoor controller board type	JP3	Factory shipment	×	Service parts	○												
Indoor controller board type	JP3																			
Factory shipment	×																			
Service parts	○																			

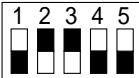
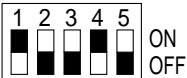
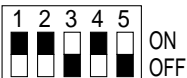
Figure1.

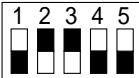
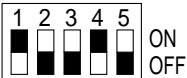
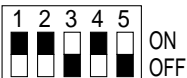

1. Removing the fan motor

1. Remove the 9 screws that fix the bottom plate ①, and remove it.
2. Removing the drain pan as follows:
 - (1) Remove the screw that fix the drain pan.
 - (2) Slide the drain pan in the direction ①, Figure1 and unhook the drain pan catch near the drain pipe.
 - (3) Slide the drain pan in the direction ②, Figure1 and unhook the 2 catches on the other side of the drain pipe.
3. Remove the 8 screws that fix the bottom plate assembly, and remove it.
4. Disconnect the fan motor connector from the controller box.

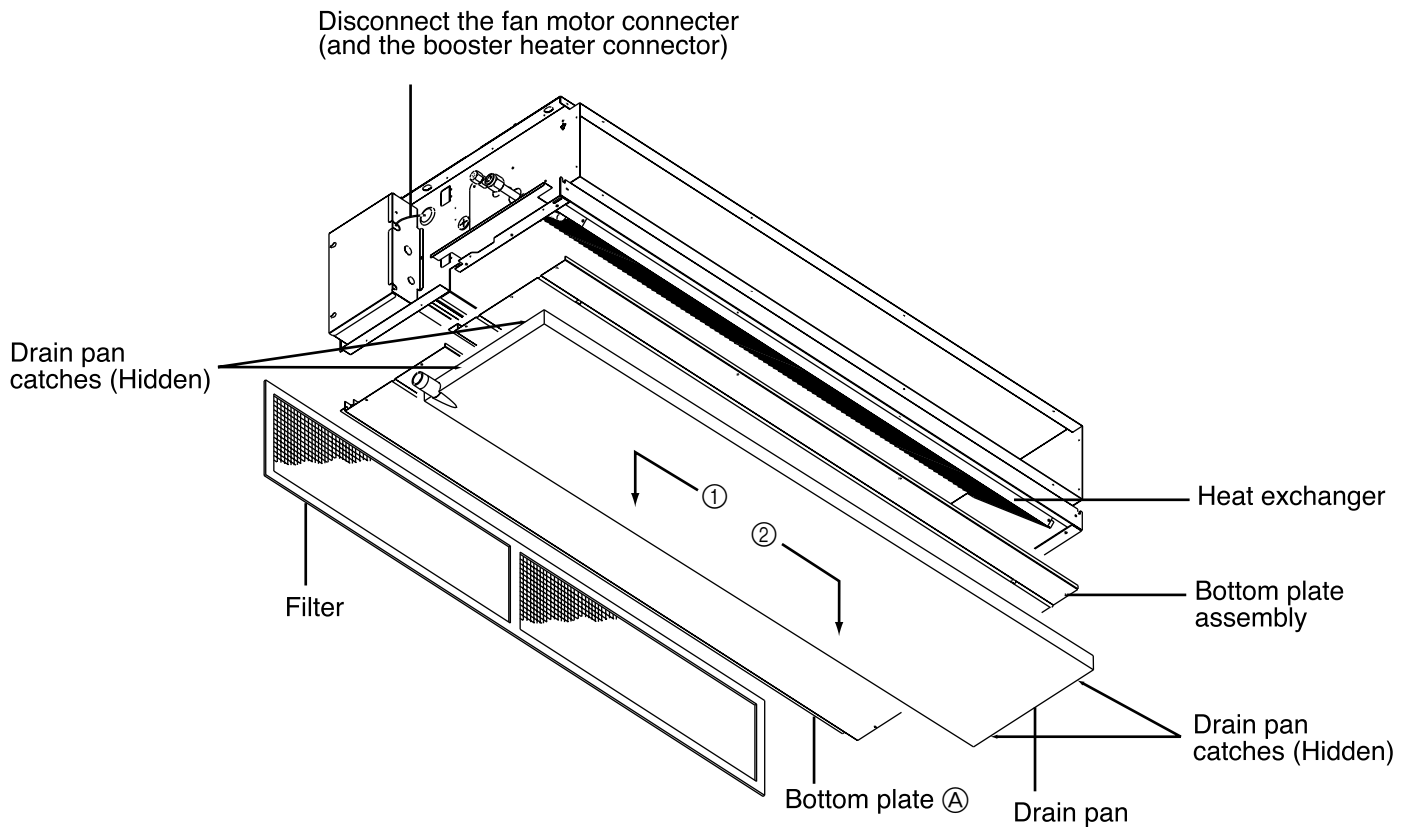
5. Remove the fan base plate as follow:

Figure2.

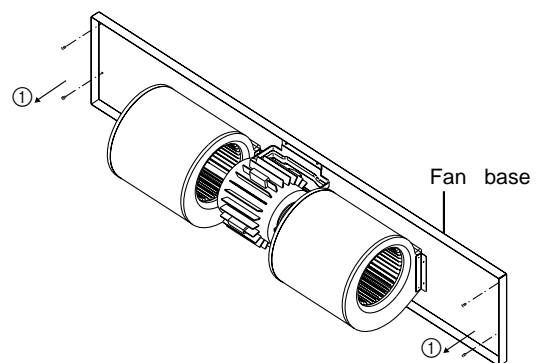

- (1) Remove the 4 screws ①
- (2) Slide down the fan base plate to remove.

6. Remove the sirocco fan setting screw and the motor fixture setting screw to remove the motor fixture.
Remove the other motor fixture as well, and then remove the fan motor. (Figure 3)

Figure3.

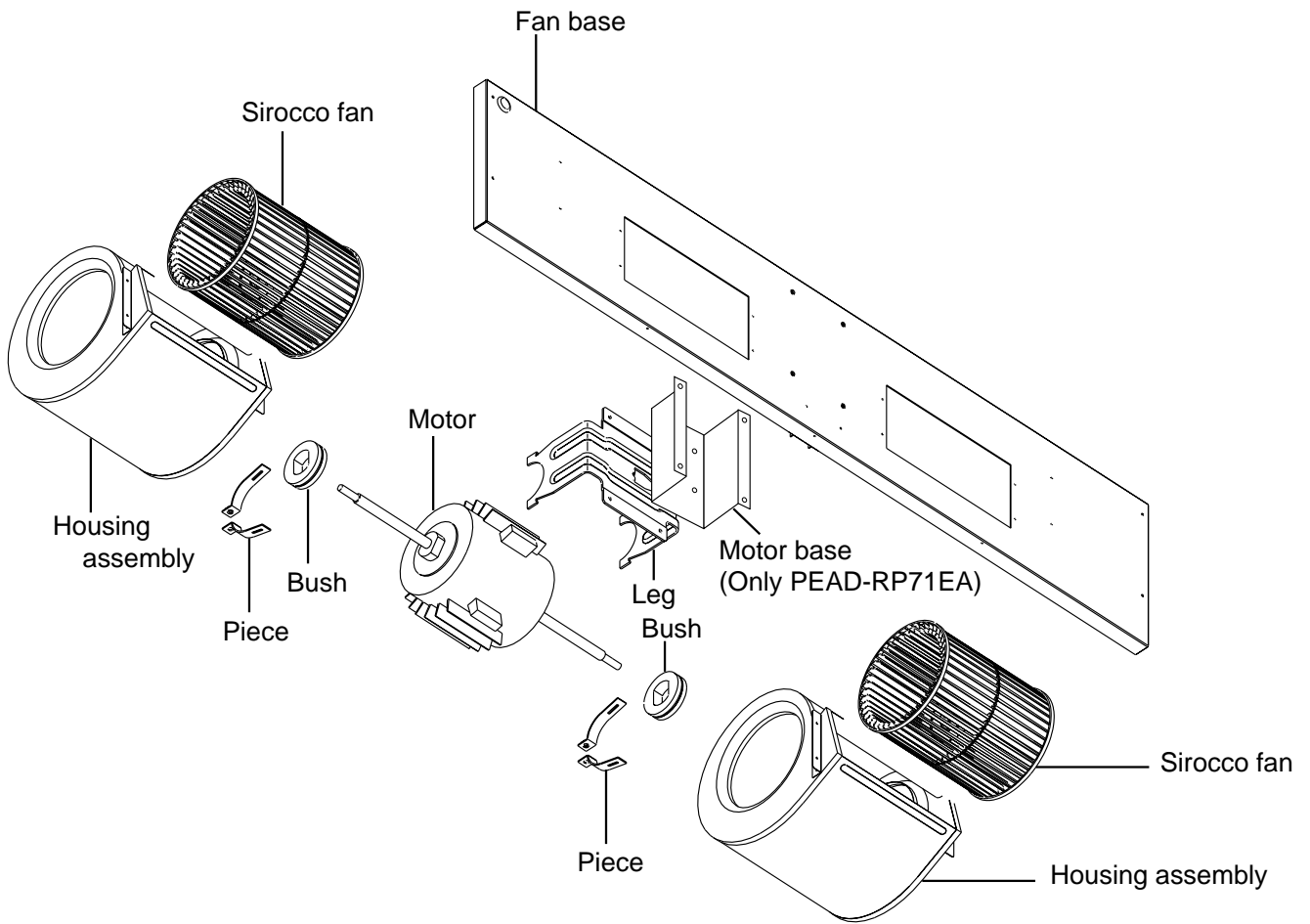

12

PARTS LIST

PEAD-RP35EA, PEAD-RP35EA2, PEAD-RP50EA, PEAD-RP60EA

EXTERNAL PARTS

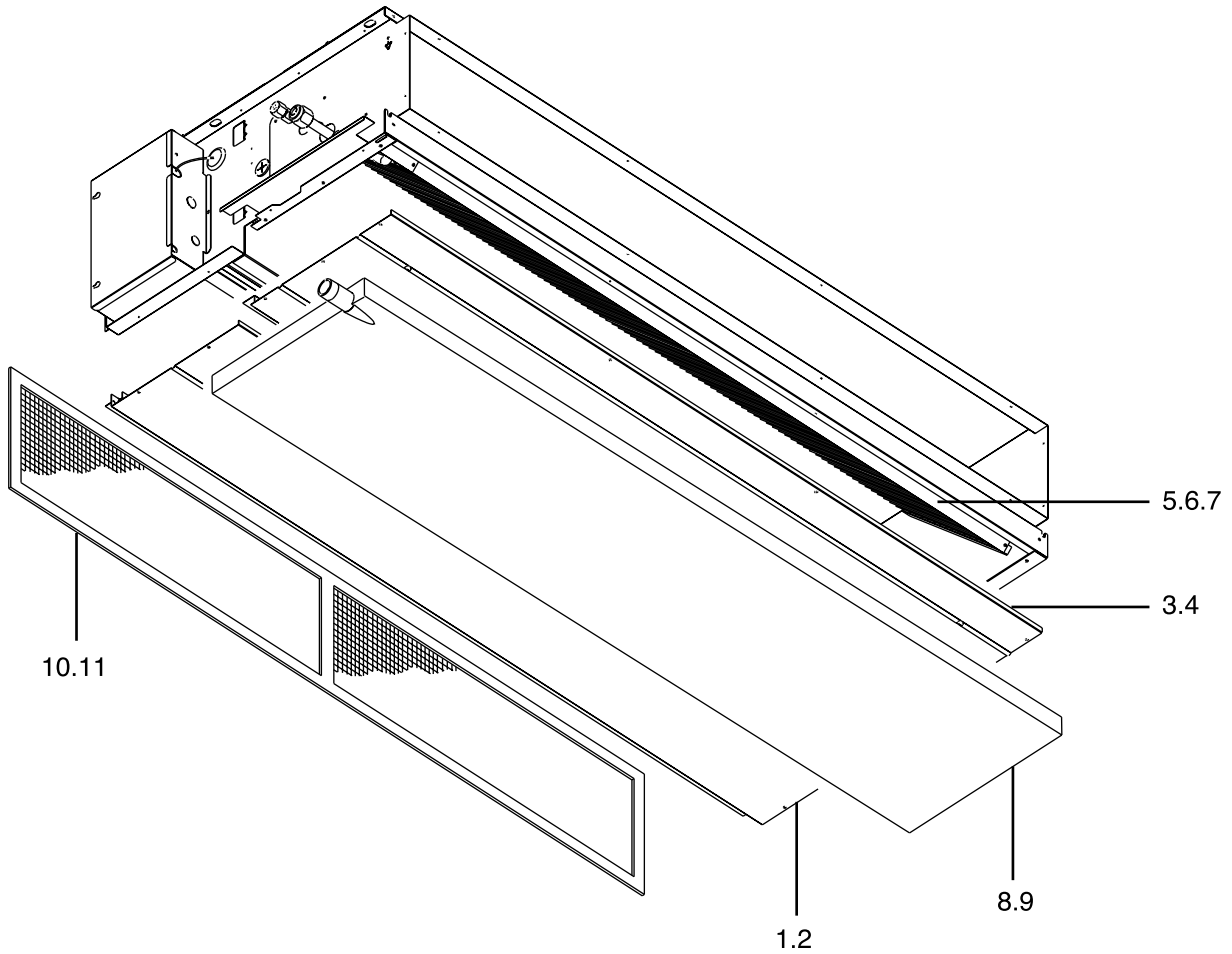

No.	Part No.	Part Name	Drawing No.	Qt'y/set				Spec.
				PEAD-RP35EA	PEAD-RP35EA2	PEAD-RP50EA	PEAD-RP60EA	
1	S70 031 669	Bottom plate 1	W638939Z04	1	1	1		
2	S70 011 669	Bottom plate 1	W638917Z04				1	
3	S70 081 669	Bottom plate 2 ass'y	W638940G03	1	1	1		
4	S70 091 669	Bottom plate 2 ass'y	W638918G03				1	
5	S70 K10 480	H.EX.General ass'y	W268527G13	1	1			
6	S70 K11 480	H.EX.General ass'y	W268527G14			1		
7	S70 K12 480	H.EX.General ass'y	W268527G15				1	
8	S70 011 529	Drain pan ass'y	W638942G01	1	1	1		
9	S70 021 529	Drain pan ass'y	W638920G01				1	
10	S70 021 500	Filter	W645496G02	1	1	1		
11	S70 031 500	Filter	W645496G03				1	

**PEAD-RP71EA, PEAD-RP100EA, PEAD-RP100EA2,
PEAD-RP125EA, PEAD-RP140EA**

EXTERNAL PARTS

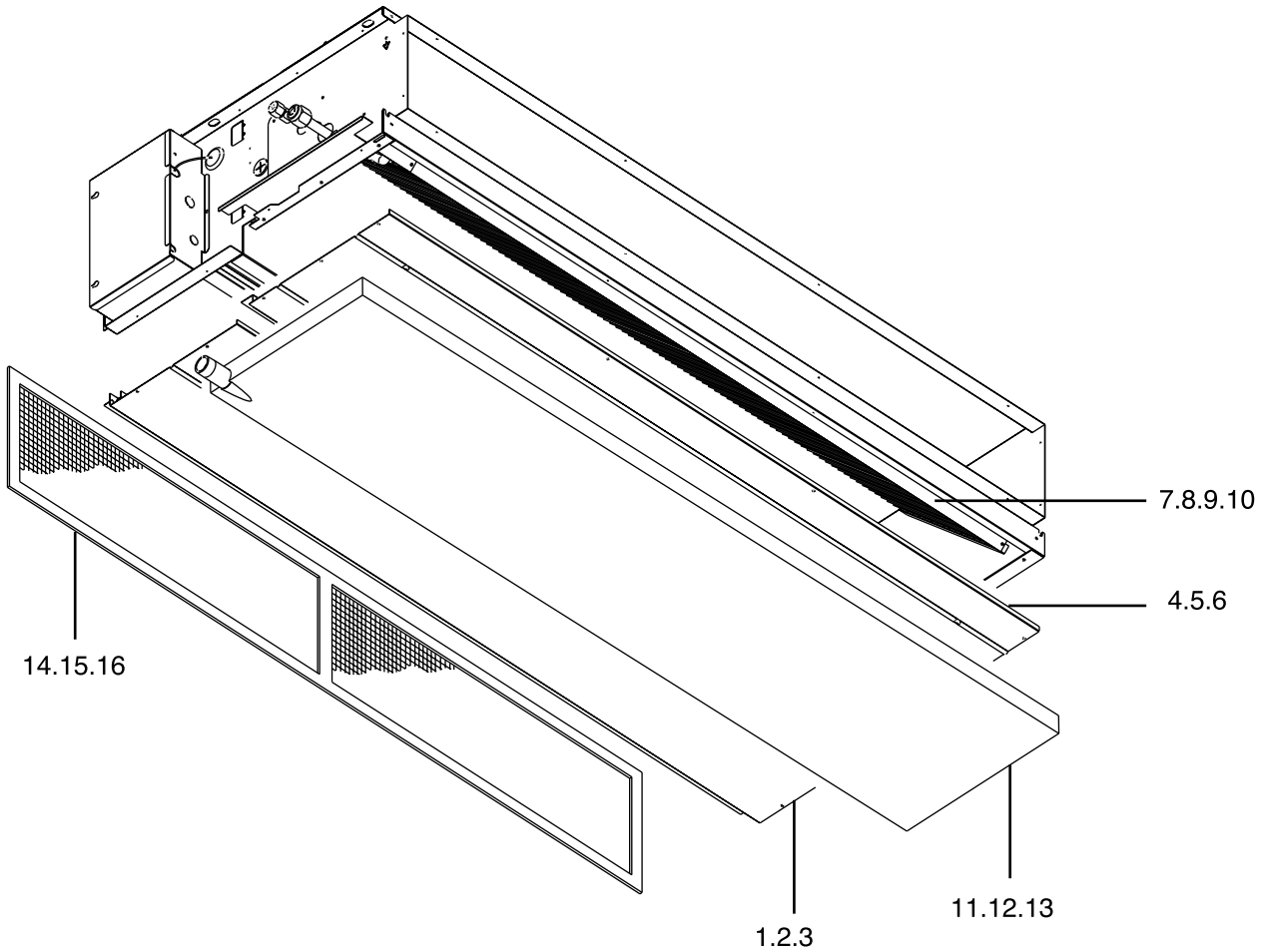

No.	Part No.	Part Name	Drawing No.	Qt'y/set					Spec.
				PEAD-RP71EA	PEAD-RP100EA	PEAD-RP100EA2	PEAD-RP125EA	PEAD-RP140EA	
1	S70 041 669	Bottom plate 1	W634050Z01	1					
2	S70 042 669	Bottom plate 1	W634028Z01		1	1	1		
3	S70 040 669	Bottom plate 1	W631101Z04					1	
4	S70 051 669	Bottom plate 2 ass'y	W634052G01	1					
5	S70 052 669	Bottom plate 2 ass'y	W634030G01		1	1	1		
6	S70 050 669	Bottom plate 2 ass'y	W631188G02					1	
7	S70 K06 480	H.EX.General ass'y	W268528G07	1					
8	S70 K13 480	H.EX.General ass'y	W268528G10		1				
9	S70 K14 480	H.EX.General ass'y	W268528G11			1	1		
10	S70 K15 480	H.EX.General ass'y	W268529G04					1	
11	S70 050 529	Drain pan ass'y	W634056G01	1					
12	S70 060 529	Drain pan ass'y	W634034G01		1	1	1		
13	S70 040 529	Drain pan ass'y	W631186G01					1	
14	S70 050 500	Filter	W645497G01	1					
15	S70 040 500	Filter	W645497G02		1	1	1		
16	S70 010 500	Filter	W645497G03					1	

PEAD-RP35EA, PEAD-RP35EA2, PEAD-RP50EA, PEAD-RP60EA

BLOWER PARTS

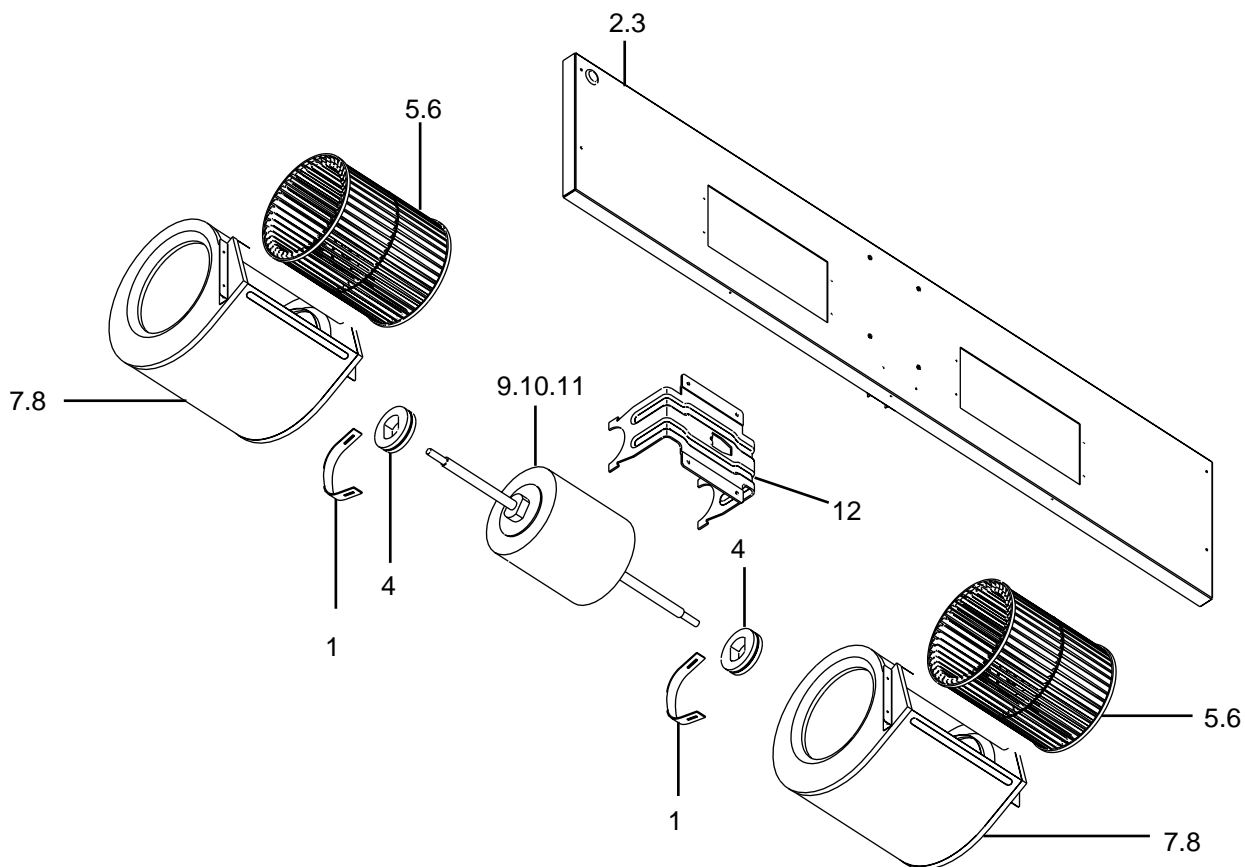

No.	Part No.	Part Name	Drawing No.	Qt'y/set				Spec.
				PEAD-RP35EA	PEAD-RP35EA2	PEAD-RP50EA	PEAD-RP60EA	
1	S70 652 131	Attachment	W353715H01	2	2	2	2	
2	S70 051 677	Fan base ass'y	W638932G03	1	1	1		
3	S70 061 677	Fan base ass'y	W638905G03				1	
4	S70 922 105	Bush	W818836H01	2	2	2	2	
5	S70 A88 114	Sirocco fan	W122296G02	2	2	2		
6	S70 A89 114	Sirocco fan	W122297G02				2	
7	S70 989 110	Housing ass'y	W638949G03	2	2	2		
8	S70 985 110	Housing ass'y	W638949G04				2	
9	S70 Y57 220	Motor	P714315X02	1				<MF>
10	S70 Y58 220	Motor	P714316X02		1	1		<MF>
11	S70 Y56 220	Motor	P714774X01				1	<MF>
12	S70 652 130	Motor support	W241060H03	1	1	1	1	

**PEAD-RP71EA, PEAD-RP100EA, PEAD-RP100EA2,
PEAD-RP125EA, PEAD-RP140EA**

BLOWER PARTS

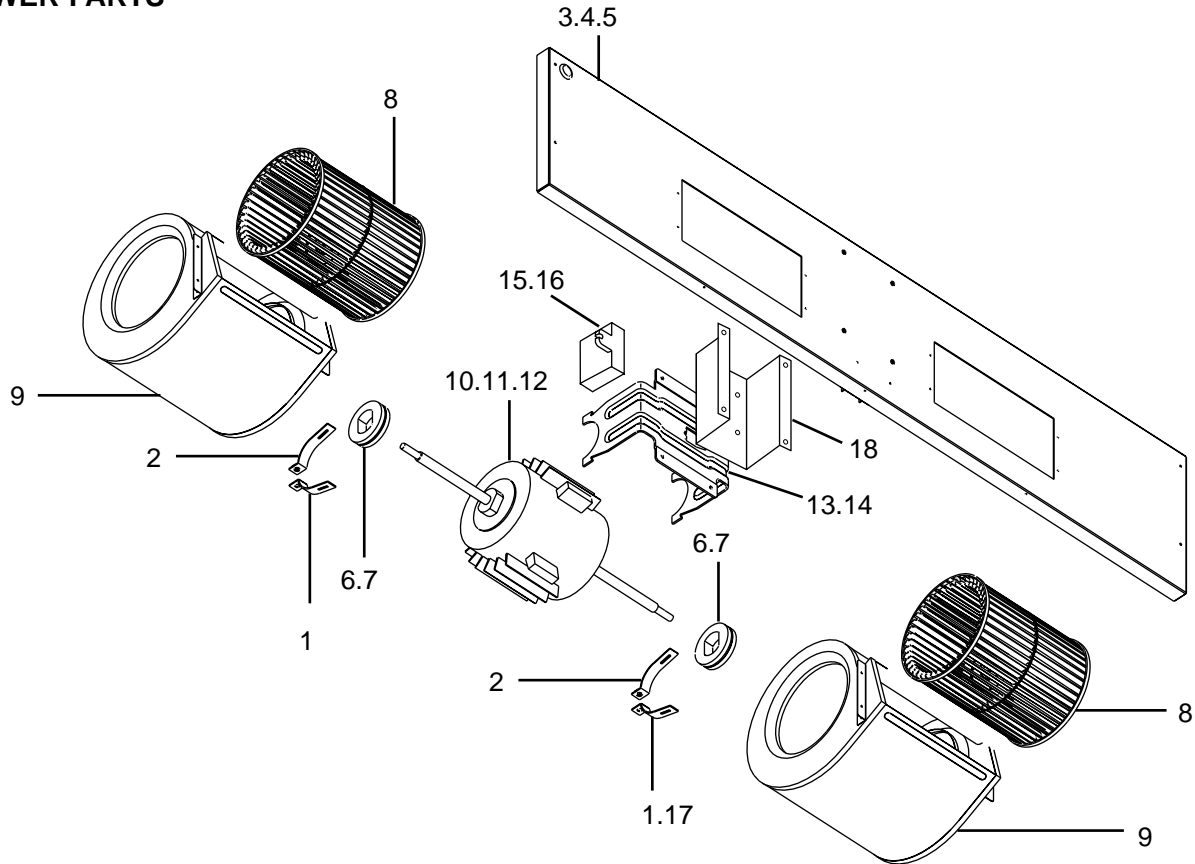

No.	Part No.	Part Name	Drawing No.	Qt'y/set					Spec.
				PEAD-RP71EA	PEAD-RP100EA	PEAD-RP100EA2	PEAD-RP125EA	PEAD-RP140EA	
1	S70 508 131	Piece	R02K338H02		2	2	2	2	
2	S70 508 132	Piece	R02K338G82		2	2	2	2	with a nut
3	S70 073 677	Fan base ass'y	W634058G02	1					
4	S70 072 677	Fan base ass'y	W634036G02		1	1	1		
5	S70 070 677	Fan base ass'y	W631187G02					1	
6	S70 922 105	Bush	W818836H01	2					
7	S70 Y01 105	Bush	W860050H02		2	2	2	2	
8	S70 Y07 114	Sirocco fan	W631126G02	2	2	2	2	2	20-25L
9	S70 001 110	Housing ass'y	W631120G02	2	2	2	2	2	
10	S70 Y15 220	Motor	P714964X01	1					<MF>150W,1Phase 220- 240V
11	S70 Y16 220	Motor	P714941X01		1				<MF>240W,1Phase 220- 240V
12	S70 Y17 220	Motor	P714940X01			1	1	1	<MF>270W,1Phase 220- 240V
13	S70 652 130	Motor support	W241060H03	1					
14	S70 Y08 130	Leg	W631122Z04		1	1	1	1	
15	S70 010 255	Capacitor 6	P412172X01		1				< C >
16	S70 020 255	Capacitor 16	P412223X01			2	2	2	< C >
* 17	S70 652 131	Attachment	W353715H01	2					
18	S70 090 130	Motor base	W634069Z02	1					

*: Not illustrated

**PEAD-RP35EA, PEAD-RP35EA₂, PEAD-RP50EA, PEAD-RP60EA,
PEAD-RP71EA, PEAD-RP100EA, PEAD-RP100EA₂, PEAD-RP125EA,
PEAD-RP140EA**

CONTROL BOX PARTS

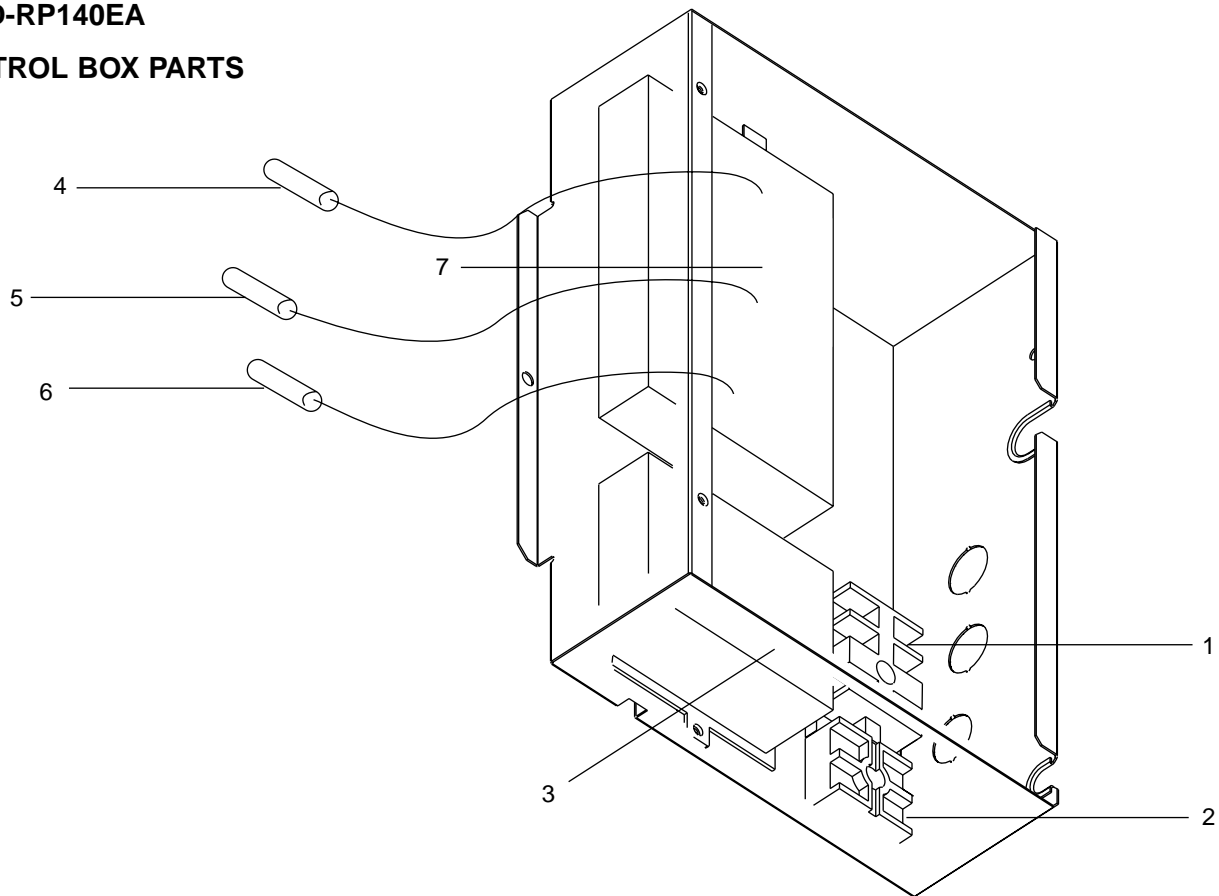

No.	Part No.	Part Name	Drawing No.	Qt'y/set				Spec.
				PEAD-RP35EA	PEAD-RP35EA ₂	PEAD-RP50EA	PEAD-RP60EA	
1	S70 979 717	Terminal bed	P436110X01	1	1	1	1	< TB4 >
2	S70 435 717	Terminal bed	BA73S950H02	1	1	1	1	< TB5 >
3	S70 K06 313	Power Board	RG00B435F08	1	1	1	1	PWB
4	S70 KW3 202	Thermistor	W905588G01	1	1	1	1	< TH1 > RED
5	S70 KW2 202	Thermistor	W906303G02	1	1	1	1	< TH2 > WHITE
6	S70 KW1 202	Thermistor	W906303G01	1	1	1	1	< TH5 > BLACK
7	S70 K70 310	Controller board	RG00D008B02	1	1	1	1	I.B

No.	Part No.	Part Name	Drawing No.	Qt'y/set					Spec.
				PEAD-RP71EA	PEAD-RP100EA	PEAD-RP100EA ₂	PEAD-RP125EA	PEAD-RP140EA	
1	S70 979 317	Terminal bed	P436110X01	1	1	1	1	1	< TB4 >
2	S70 435 717	Terminal bed	BA73S950H02	1	1	1	1	1	< TB5 >
3	S70 K06 313	Power Board	RG00B435F08	1	1	1	1	1	PWB
4	S70 KW3 202	Thermistor	W905588G01	1	1	1	1	1	< TH1 > RED
5	S70 KW2 202	Thermistor	W906303G02	1	1	1	1	1	< TH2 > WHITE
6	S70 KW1 202	Thermistor	W906303G01	1	1	1	1	1	< TH5 > BLACK
7	S70 K70 310	Controller board	RG00D008B02	1	1	1	1	1	I.B

PEAD-RP35EA, PEAD-RP35EA2, PEAD-RP50EA, PEAD-RP60EA,
 PEAD-RP71EA, PEAD-RP100EA, PEAD-RP100EA2, PEAD-RP125EA,
 PEAD-RP140EA

ELECTRICAL PARTS

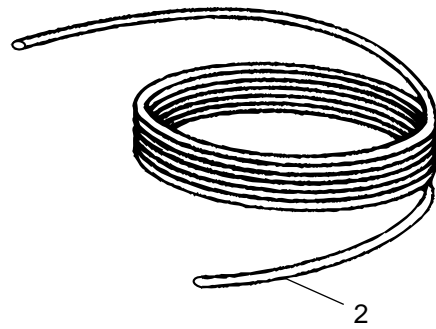
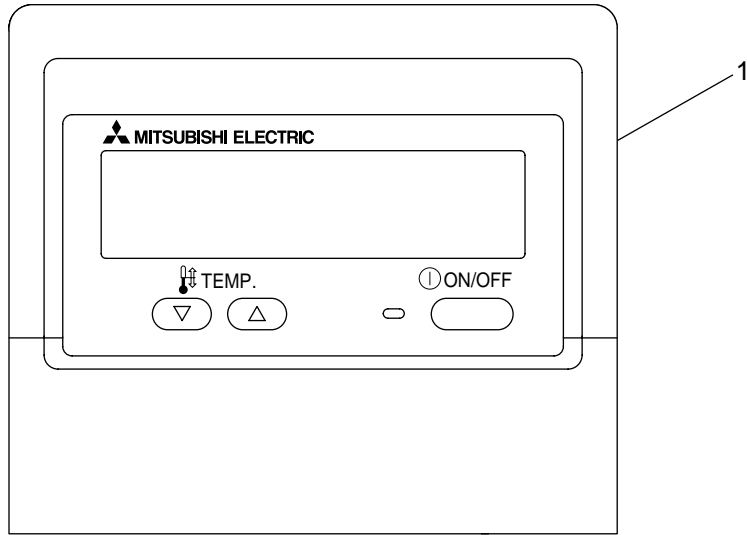

No.	Part No.	Part Name	Drawing No.	Qt'y/set				Spec.
				PEAD-RP35EA	PEAD-RP35EA2	PEAD-RP50EA	PEAD-RP60EA	
1	S70 KW1 713	Remote controller	P972122X01	1	1	1	1	MA Remo-con
2	S70 030 305	Remote controller cable	W873334G05	1	1	1	1	10 m

No.	Part No.	Part Name	Drawing No.	Qt'y/set					Spec.
				PEAD-RP71EA	PEAD-RP100EA	PEAD-RP100EA2	PEAD-RP125EA	PEAD-RP140EA	
1	S70 KW1 713	Remote controller	P972122X01	1	1	1	1	1	MA Remo-con
2	S70 030 305	Remote controller cable	W873334G05	1	1	1	1	1	10 m

13 OPTIONAL PARTS

1. REMOTE SENSOR

Part No.	PAC-SE41TS-E
Applied model	PEAD-RP35,50,60,71,100,125,140EA , PEAD-RP35,100EA ₂

2. REMOTE OPERATION ADAPTER

Part No.	PAC-SF40RM-E
Applied model	PEAD-RP35,50,60,71,100,125,140EA , PEAD-RP35,100EA ₂

3. REMOTE ON/OFF ADAPTER

Part No.	PAC-SE55RA-E
Applied model	PEAD-RP35,50,60,71,100,125,140EA , PEAD-RP35,100EA ₂

4. OPTIONAL MOTOR

The external static pressure of 130Pa allows long ducts to be used more extensively to enable the most convenient positioning of indoor units.

Part No.	PAC-SK005MT-F	PAC-SK004MT-F	PAC-SK003MT-F
Applied model	PEAD-RP71EA	PEAD-RP100EA	PEAD-RP125,140EA, PEAD-RP100EA ₂

5. DRAIN WATER LIFT-UP MECHANISM

This allows more versatility when selecting drain piping layouts.

Part No.	PAC-KE03DM-G
Applied model	PEAD-RP35,50,60,71,100,125,140EA , PEAD-RP35,100EA ₂

Mr. SLIM™

 **mitsubishi electric corporation**