

Air Conditioning

Product Information

MSZ-SF35VE : Inverter Heat Pump

R410A Wall Mounted System

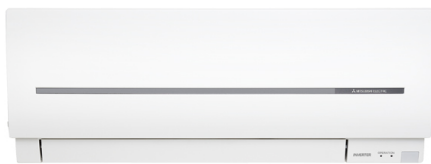

The MSZ series has been completely redesigned offering a stylish and efficient system.

These models offer industry leading noise levels and have a distinctively styled front panel that not only looks appealing, but also helps to make cleaning of the unit easier.

FEATURES



INDOOR

Heating Capacity (kW) (nominal)	4 (1.3 - 4.6)
Cooling Capacity (kW) (nominal)	3.5 (1.1 - 3.8)
Heating Capacity (kW) (UK)	3.32 (1.1 - 3.82)
Cooling Capacity (kW) (UK)	3.47 (1.1 - 3.77)
SHF (nominal and UK)	0.8
COP / EER (nominal)	3.88 / 3.24
SCOP / SEER	4.4 / 7.2
Energy Efficiency Class - Heating / Cooling	A+ / A++
Airflow (m³/min) (Heating) - Si-Lo-Mi-Hi-SupHi	3.5 - 4.1 - 6.7 - 8.3 - 11
Airflow (m³/min) (Cooling) - Si-Lo-Mi-Hi-SupHi	3.5 - 4.1 - 5.6 - 7.2 - 9.1
Pipe Size Gas (mm [in])	9.52 (3/8)
Pipe Size Liquid (mm [in])	6.35 (1/4)
Sound Pressure Level (dBA) Heating - Si-Lo-Mi-Hi-SupHi	21 - 24 - 34 - 40 - 46
Sound Pressure Level (dBA) Cooling - Si-Lo-Mi-Hi-SupHi	21 - 24 - 30 - 36 - 42
Sound Power Level (dBA) Cooling	57
Dimensions (mm) Width x Depth x Height	798 x 195 x 299
Weight (kg)	10
Electrical Supply	FED BY OUTDOOR UNIT
Phase	SINGLE
Fuse Rating (BS88) - HRC (A)	6
Interconnecting Cable No. Cores	4

OUTDOOR

Sound Pressure Level (dBA) Heating / Cooling	50 / 49
Sound Power Level (dBA) Cooling	62
Weight (kg)	31
Dimensions (mm) Width x Depth x Height	800 x 285 x 550
Electrical Supply	220-240V, 50HZ
Phase	SINGLE
System Power Input (kW) - Heating / Cooling (nominal)	1.03 / 1.08
System Power Input (kW) - Heating / Cooling (UK)	0.94 / 0.87
Starting Current (A)	4.9
System Running Current (A) [MAX] - Heating / Cooling	4.7 / 4.9 [8.5]
Fuse Rating (BS88) - HRC (A)	10
Mains Cable No. Cores	3
Max Pipe Length (m)	20
Max Height Difference (m)	12
Charge R410A (kg) - (pre charged length)	0.8 (7)

DIMENSIONS

MSZ-SF25_50

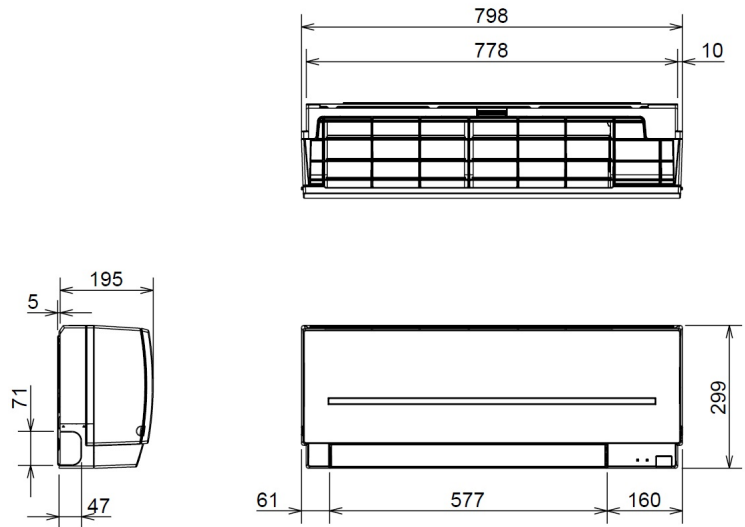

DIMENSIONS

MUZ-SF25_50

