

Revision A:

- MUZ-A18YV -[E1] can be connected to MCFZ-A18WV -[E1].
- MUZ-A24YV -[E1] can be connected to MCFZ-A24WV -[E1].

Please void OB346.

SERVICE MANUAL



**Wireless type
Models**

**No. OB346
REVISED EDITION-A**

MUZ-A18YV -[E1]
MUZ-A24YV -[E1]
MUZ-A26YV -[E1]

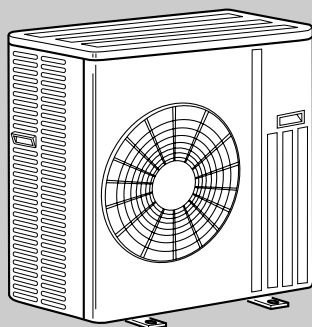

Indication of
model name

MUZ-A18YV -[E1]
MUZ-A24YV -[E1]
MUZ-A26YV -[E1]

CONTENTS

1. TECHNICAL CHANGES	2
2. PART NAMES AND FUNCTIONS.....	5
3. SPECIFICATION.....	5
4. NOISE CRITERIA CURVES	8
5. OUTLINES AND DIMENSIONS	9
6. WIRING DIAGRAM	10
7. REFRIGERANT SYSTEM DIAGRAM	12
8. PERFORMANCE CURVES	14
9. ACTUATOR CONTROL.....	29
10. TROUBLESHOOTING.....	30
11. DISASSEMBLY INSTRUCTIONS.....	44
12. PARTS LIST.....	48

NOTE:

This service manual describes technical data of the outdoor units.

- As for indoor units MSZ-A18YV -[E1], MSZ-A24YV -[E1] and MSZ-A26YV -[E1], refer to the service manual OB345.
- As for indoor units MCFZ-A18WV -[E1] and MCFZ-A24WV -[E1], refer to the service manual OB344 REVISED EDITION-A.



INFORMATION FOR THE AIR CONDITIONER WITH R410A REFRIGERANT

- This room air conditioner adopts an HFC refrigerant (R410A) which never destroys the ozone layer.
 - Pay particular attention to the following points, though the basic installation procedure is same as that for R22 air conditioners.
- ① As R410A has working pressure approximate 1.6 times as high as that of R22, some special tools and piping parts/materials are required. Refer to the table below.
 - ② Take sufficient care not to allow water and other contaminations to enter the R410A refrigerant during storage and installation, since it is more susceptible to contaminations than R22.
 - ③ For refrigerant piping, use clean, pressure-proof parts/materials specifically designed for R410A. (Refer to 2. Refrigerant piping.)
 - ④ Composition change may occur in R410A since it is a mixed refrigerant. When charging, charge liquid refrigerant to prevent composition change.

		New refrigerant	Previous refrigerant
Refrigerant	Refrigerant	R410A	R22
	Composition (Ratio)	HFC-32: HFC-125 (50%:50%)	R22 (100%)
	Refrigerant handling	Pseudo-azeotropic refrigerant	Single refrigerant
	Chlorine	Not included	Included
	Safety group (ASHRAE)	A1/A1	A1
	Molecular weight	72.6	86.5
	Boiling point (°C)	-51.4	-40.8
	Steam pressure [25°C](Mpa)	1.557	0.94
	Saturated steam density [25°C](Kg/m ³)	64	44.4
	Combustibility	Non combustible	Non combustible
	ODP ※1	0	0.055
	GWP ※2	1730	1700
	Refrigerant charge method	From liquid phase in cylinder	Gas phase
	Additional charge on leakage	Possible	Possible
Refrigerating oil	Kind	Incompatible oil	Compatible oil
	Color	Non	Light yellow
	Smell	Non	Non

※1 :Ozone Destruction Parameter : based on CFC-11

※2 :Global Warmth Parameter : based on CO₂

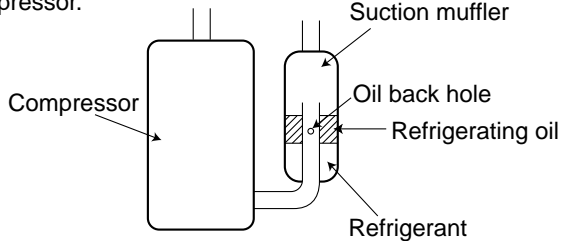
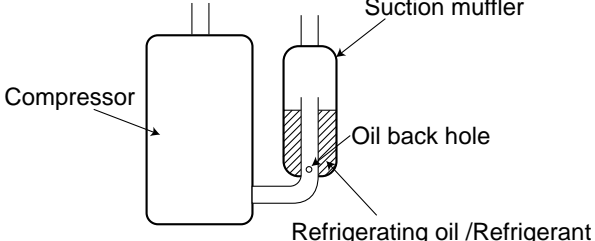
		New Specification	Current Specification
Compressor		<p>The incompatible refrigerating oil easily separates from refrigerant and is in the upper layer inside the suction muffler. Raising position of the oil back hole enables to back the refrigerating oil of the upper layer to flow back to the compressor.</p> 	<p>Since refrigerant and refrigerating oil are compatible each, refrigerating oil backs to the compressor through the lower position oil back hole.</p> 

NOTE : The unit of pressure has been changed to MPa on the international system of units(SI unit system).

The conversion factor is: **1(MPa [Gauge]) =10.2(kgf/cm² [Gauge])**

Conversion chart of refrigerant temperature and pressure

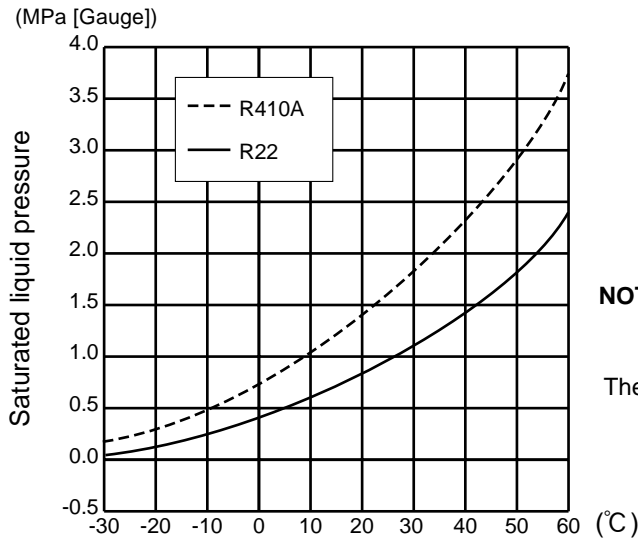

NOTE : The unit of pressure has been changed to MPa on the international system of units(SI unit system).

The conversion factor is: **1(MPa [Gauge]) =10.2(kgf/cm² [Gauge])**

1.Tools dedicated for the air conditioner with R410A refrigerant

The following tools are required for R410A refrigerant. Some R22 tools can be substituted for R410A tools.

The diameter of the service port on the stop valve in outdoor unit has been changed to prevent any other refrigerant being charged into the unit. Cap size has been changed from 7/16 UNF with 20 threads to 1/2 UNF with 20 threads.

R410A tools	Can R22 tools be used?	Description
Gauge manifold	No	R410A has high pressures beyond the measurement range of existing gauges. Port diameters have been changed to prevent any other refrigerant from being charged into the unit.
Charge hose	No	Hose material and cap size have been changed to improve the pressure resistance.
Gas leak detector	No	Dedicated for HFC refrigerant.
Torque wrench	Yes	6.35 mm and 9.52 mm
	No	12.7 mm and 15.88mm
Flare tool	Yes	Clamp bar hole has been enlarged to reinforce the spring strength in the tool.
Flare gauge	New	Provided for flaring work (to be used with R22 flare tool).
Vacuum pump adapter	New	Provided to prevent the back flow of oil. This adapter enables you to use vacuum pumps.
Electronic scale for refrigerant charging	New	It is difficult to measure R410A with a charging cylinder because the refrigerant bubbles due to high pressure and high-speed vaporization

No : Not Substitutable for R410A Yes : Substitutable for R410A

2.Refrigerant piping

① Specifications

Use the refrigerant pipes that meet the following specifications.

Pipe	Outside diameter	Wall thickness	Insulation material
	mm		
For liquid	6.35	0.8 mm	Heat resisting foam plastic Specific gravity 0.045 Thickness 8 mm
	9.52	0.8 mm	
For gas	12.7	0.8 mm	
	15.88	1.0 mm	

- Use a copper pipe or a copper-alloy seamless pipe with a thickness of 0.8 mm (6.35, 9.52, 12.7), 1.0 mm (15.88). Never use any pipe with a thickness less than 0.8 mm (6.35, 9.52, 12.7), 1.0 mm (15.88), as the pressure resistance is insufficient.

② Flaring work and flare nut

Flaring work for R410A pipe differs from that for R22 pipe.

For details of flaring work, refer to Installation manual "FLARING WORK".

Pipe diameter	Dimension of flare nut	
	R410A	R22
mm		
6.35	17	17
9.52	22	22
12.7	26	24
15.88	29	27

3.Refrigerant oil

Apply the special refrigeration oil (accessories: packed with indoor unit) to the flare and the union seat surfaces.

4.Air purge

- Do not discharge the refrigerant into the atmosphere.
Take care not to discharge refrigerant into the atmosphere during installation, reinstallation, or repairs to the refrigerant circuit.
- Use the vacuum pump for air purging for the purpose of environmental protection.

5.Additional charge

For additional charging, charge the refrigerant from liquid phase of the gas cylinder.

If the refrigerant is charged from the gas phase, composition change may occur in the refrigerant inside the cylinder and the outdoor unit. In this case, ability of the refrigerating cycle decreases or normal operation can be impossible. However, charging the liquid refrigerant all at once may cause the compressor to be locked. Thus, charge the refrigerant slowly.

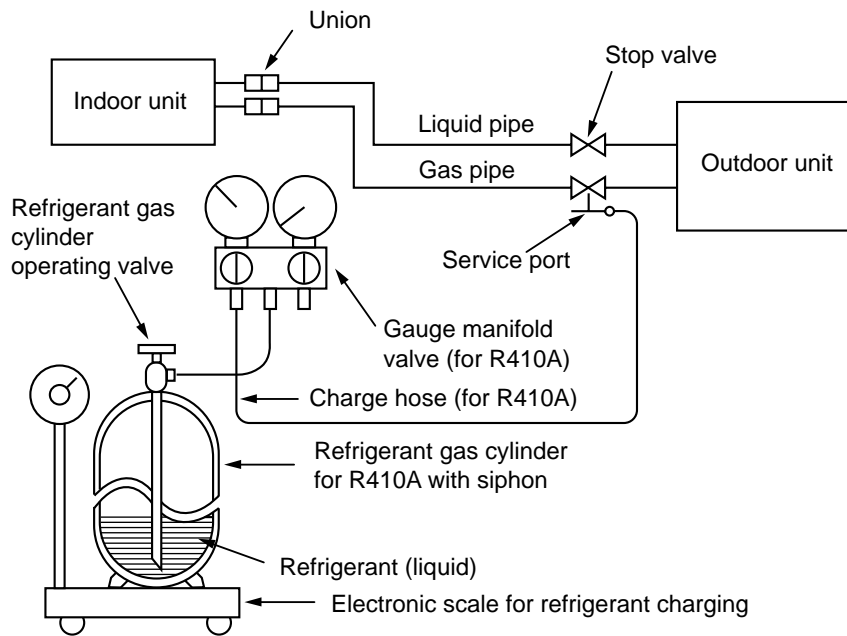

2

PART NAMES AND FUNCTIONS

MUZ-A18YV - [E1]
 MUZ-A24YV - [E1]
 MUZ-A26YV - [E1]

ACCESSORIES

OUTDOOR UNIT

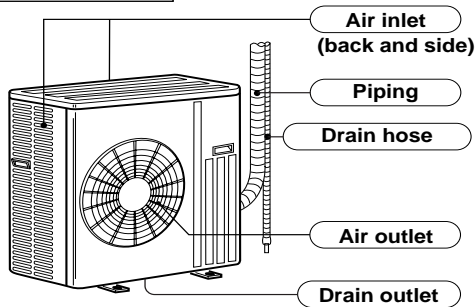

		MUZ-A18YV - [E1] MUZ-A24YV - [E1] MUZ-A26YV - [E1]
①	Drain socket	1
②	Drain cap $\phi 33$	2

3

SPECIFICATION

Outdoor model			MUZ-A18YV - [E1] Indoor model MSZ-A18YV - [E1]		MUZ-A18YV - [E1] Indoor model MCFZ-A18WV - [E1]		
Function			Cooling	Heating	Cooling	Heating	
Power supply			Single phase 230V,50Hz		Single phase 230V,50Hz		
Capacity	Capacity Rated frequency(Min.-Max.)	kW	5.0(0.9~5.9)	5.9(0.9~7.8)	4.8(10.9~5.5)	6.0(0.9~7.5)	
	Dehumidification	ℓ/h	2.5	—	2.4	—	
	Air flow(High/Low*)	m ³ /h	2,940/1,650*	2,940/2,210*	2,940/1,650*	2,940/2,210*	
Electrical data	Power outlet	A	20		20		
	Running current	A	6.62	7.38	7.76	8.87	
	Power input	W	1,500	1,670	1,750	2,000	
	Power factor	%	98.5	98.4	98		
	Starting current *1	A	7.38		8.87		
	Compressor motor current *1	A	6.32	7.08	7.46	8.57	
	Fan motor current	A	0.30		0.30		
Coefficient of performance(C.O.P) *1			3.21	3.41	2.62	2.88	
Compressor	Model		SNB130FLDH		SNB130FLDH		
	Output	W	850		850		
	Winding resistance(at 20°C)	Ω	U-V 0.45 W-U 0.45 V-W 0.45		U-V 0.45 W-U 0.45 V-W 0.45		
Fan motor	Model		PM8H60-UB		PM8H60-UB		
	Winding resistance(at 20°C)	Ω	BLK-WHT 15.2 WHT-RED 15.2 RED-BLK15.2		BLK-WHT 15.2 WHT-RED 15.2 RED-BLK15.2		
Dimensions W×H×D		mm	840×850×330		840×850×330		
Weight		kg	53		53		
Special remarks	Sound level(High/Low*)	dB	53/51*	55/53*	53/51*	55/53*	
	Fan speed(High/Low*)	rpm	800/480*	800/620*	800/480*	800/620*	
	Fan speed regulator			2		2	
	Refrigerant filling capacity(R410A)	kg	1.8		1.8		
	Refrigerating oil(Model)	cc	450 (NEO22)		450 (NEO22)		
	Thermistor RT61(at 100°C)	kΩ	13.4		13.4		
	Thermistor RT62(at 25°C)	kΩ	10.0		10.0		
	Thermistor RT65(at 50°C)	kΩ	17.0		17.0		
Thermistor RT68(at 25°C)	kΩ	10.0		10.0			

NOTE : Test conditions are based on ISO 5151.

Cooling : Indoor DB 27°C WB 19°C
 Outdoor DB 35°C WB (24°C)

Heating : Indoor DB 20°C WB 15°C
 Outdoor DB 7°C WB 6°C

Refrigerant piping length (one way): 5m

*1 Measured under rated operating frequency.

* Reference value



Outdoor model			MUZ-A24YV - E1 Indoor model MSZ-A24YV - E1		MUZ-A24YV - E1 Indoor model MCFZ-A24WV - E1		MUZ-A26YV - E1 Indoor model MSZ-A26YV - E1		
Function			Cooling	Heating	Cooling	Heating	Cooling	Heating	
Power supply			Single phase 230V,50Hz		Single phase 230V,50Hz		Single phase 230V,50Hz		
Capacity	Capacity Rated frequency(Min.-Max.)	kW	6.0(0.9~6.7)	6.8(0.9~8.1)	5.5(0.9~6.1)	6.4(0.9~7.9)	7.1(0.9~8.3)	8.1(0.9~9.6)	
	Dehumidification	ℓ/h	3.0	—	3.1	—	3.8	—	
	Air flow(High/Low*)	m³/h	2,940/1,650*	2,940/2,210*	2,940/1,650*	2,940/2,210*	2,940/1,650*	2,940/2,210*	
Electrical data	Power outlet	A	20		20		20		
	Running current	A	8.49	8.75	10.38	10.47	10.75	11.42	
	Power input	W	1,921	1,981	2,340	2,360	2,431	2,581	
	Power factor	%	98.4		98		98.3		
	Starting current *1	A	8.75		10.47		11.42		
	Compressor motor current *1	A	8.19	8.45	10.08	10.17	10.45	11.12	
	Fan motor current	A	0.30		0.30		0.30		
Coefficient of performance(C.O.P) *1			3.02	3.32	2.27	2.62	2.84	3.06	
Compressor	Model		SNB130FLDH		SNB130FLDH		TNB220FMCH		
	Output	W	850		850		1,300		
	Winding resistance(at 20°C)	Ω	U-V 0.45 W-U 0.45 V-W 0.45		U-V 0.45 W-U 0.45 V-W 0.45		U-V 1.41 W-U 1.41 V-W 1.41		
Fan motor	Model		PM8H60-UB		PM8H60-UB		PM8H60-UB		
	Winding resistance(at 20°C)	Ω	BLK-WHT 15.2 WHT-RED 15.2 RED-BLK15.2		BLK-WHT 15.2 WHT-RED 15.2 RED-BLK15.2		BLK-WHT 15.2 WHT-RED 15.2 RED-BLK15.2		
Dimensions W×H×D		mm	840×850×330		840×850×330		840×850×330		
Weight		kg	53		53		58		
Special remarks	Sound level(High/Low*)	dB	53/51*	55/53*	53/51*	55/53*	53/51*	55/53*	
	Fan speed(High/Low*)	rpm	800/480*	800/620*	800/480*	800/620*	800/480*	800/620*	
	Fan speed regulator			2		2		2	
	Refrigerant filling capacity(R410A)	kg	1.8		1.8		2.0		
	Refrigerating oil(Model)	cc	450 (NEO22)		450 (NEO22)		870 (NEO22)		
	Thermistor RT61(at 100°C)	kΩ	13.4		13.4		13.4		
	Thermistor RT62(at 25°C)	kΩ	10.0		10.0		10.0		
	Thermistor RT65(at 50°C)	kΩ	17.0		17.0		17.0		
Thermistor RT68(at 25°C)	kΩ	10.0		10.0		10.0			

NOTE : Test conditions are based on ISO 5151.

Cooling : Indoor DB 27°C WB 19°C

Outdoor DB 35°C WB (24°C)

Heating : Indoor DB 20°C WB 15°C

Outdoor DB 7°C WB 6°C

Refrigerant piping length (one way): 5m

*1 Measured under rated operating frequency.

* Reference value

Specifications and rating conditions of main electric parts

OUTDOOR UNIT

Item	Model	MUZ-A18YV - [E1]	MUZ-A24YV - [E1]	MUZ-A26YV - [E1]
Smoothing capacitor	(CB1,2,3)	560 μ F 450V		
Current transformer	(CT1,2)	ETQ19Z68AY		
Current transformer	(CT61)	ETQ19Z53AY		
Fuse	(F801, F912)	250V 3.15A		
Fuse	(F911)	250V 1A		
Fet array	(HC932)	SLA5075		
High pressure switch	(HPS)	-		ACB-DB156
Power transistor module	(IPM)	PS21244-A		
Reactor	(L)	340 μ H 20A		
Expansion valve	(LEV)	CAM-30YGME 12VDC		CAM-40YGME 12VDC
Power factor controller	(PFC)	PS51259-A		
Resistor	(R64)	10 Ω 20W		
Resistor	(R934A,B)	1.1 Ω 2W 2%		
Resistor	(RS1~4)	0.04 Ω 7W		
Solenoid coil relay	(SSR61)	TLP3506		
Terminal block	(TB1)	3P		
Terminal block	(TB2)	2P		
Relay	(X64)	G4A		
R.V. coil	(21S4)	LD30013		

4

NOISE CRITERIA CURVES

MUZ-A18YV -E1
 MUZ-A24YV -E1
 MUZ-A26YV -E1

SPEED	FUNCTION	SPL(dB(A))	LINE
High	COOLING	53	●—●
	HEATING	55	○—○

Test conditions,

Cooling : Dry-bulb temperature 35°C Wet-bulb temperature (24°C)
 Heating : Dry-bulb temperature 7°C Wet-bulb temperature 6°C

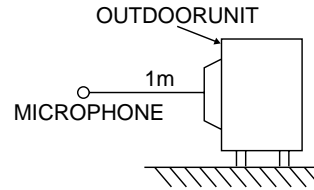
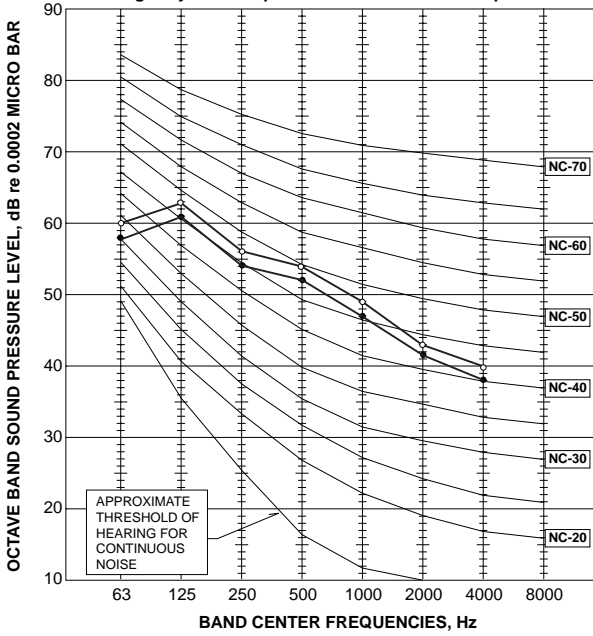

5

OUTLINES AND DIMENSIONS

MUZ-A18YV -E1
 MUZ-A24YV -E1
 MUZ-A26YV -E1

Unit: mm

OUTDOOR UNIT

REQUIRED SPACE

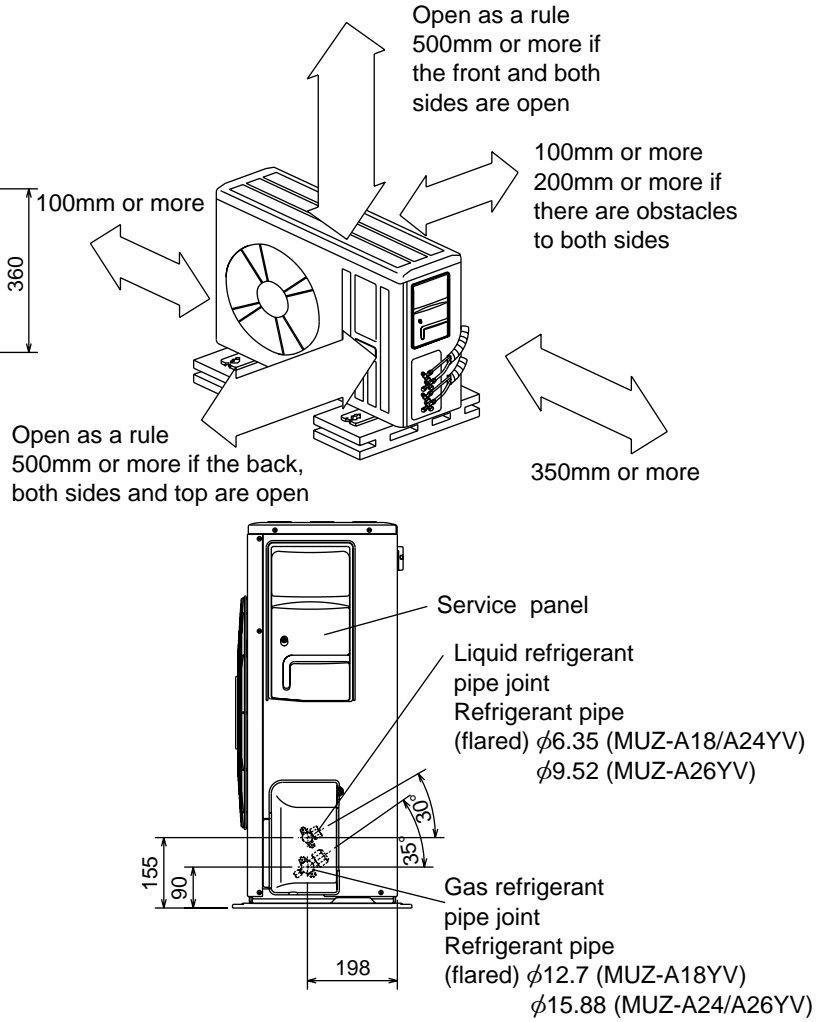
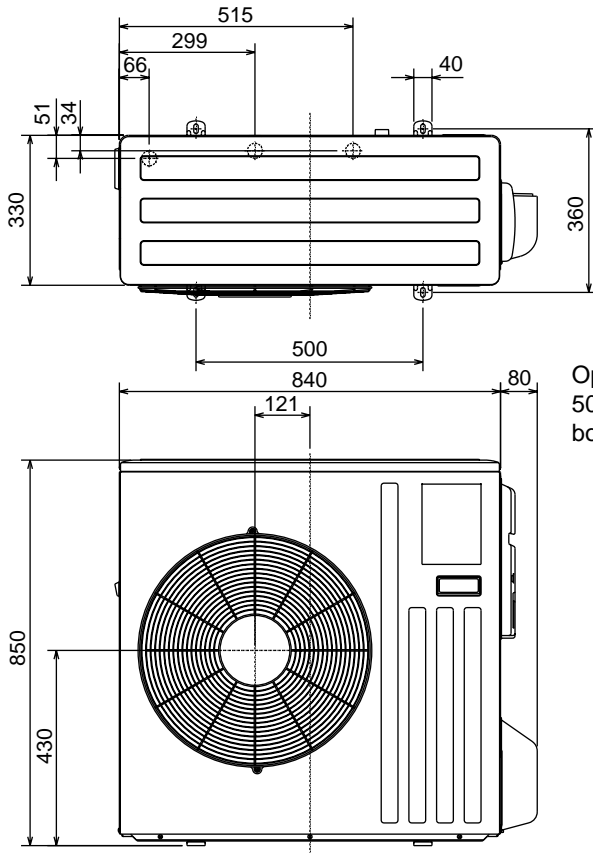

6

WIRING DIAGRAM

MUZ-A18YV - E1
 MUZ-A24YV - E1

OUTDOOR UNIT

MODELS WIRING DIAGRAM

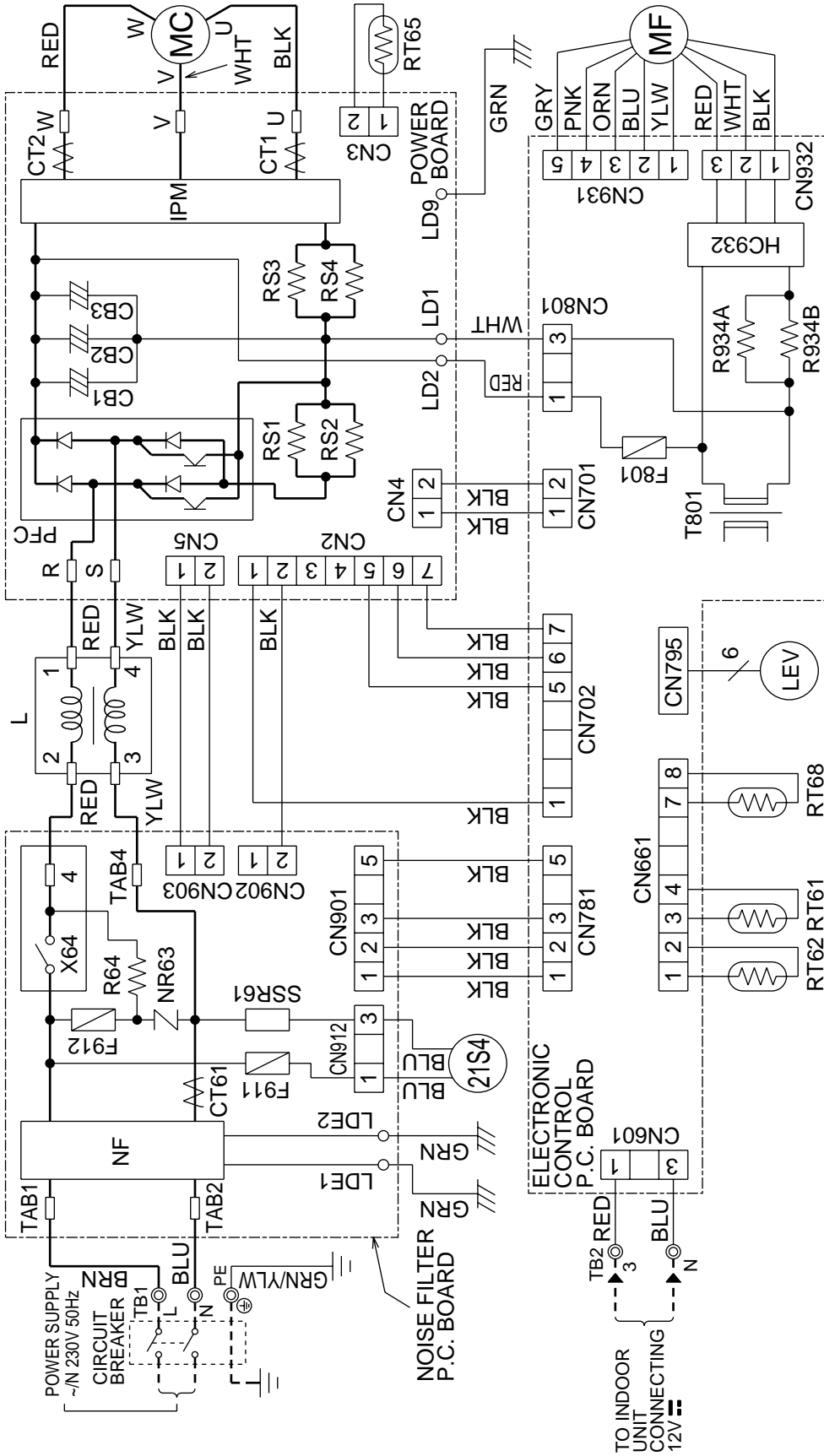

- NOTES:
1. About the indoor side electric wiring refer to the indoor unit electric wiring diagram for servicing.
 2. Use copper conductors only (for field wiring).
 3. Symbols below indicate.
 - ⊕: Terminal block
 - : Connector

SYMBOL	NAME	SYMBOL	NAME	SYMBOL	NAME
CB1-3	SMOOTHING CAPACITOR	MC	COMPRESSOR	RT65	FIN TEMPERATURE THERMISTOR
CT1, 2	CURRENT TRANSFORMER	MF	OUTDOOR FAN MOTOR (INNER FUSE)	RT68	OUTDOOR HEAT EXCHANGER TEMPERATURE THERMISTOR
CT61	CURRENT TRANSFORMER	NF	NOISE FILTER	SSR61	SOLENOID COIL RELAY
F801	FUSE (250V 3.15A)	NR63	VARIATOR	T801	TRANSFORMER
F911	FUSE (250V 1A)	PFC	POWER FACTOR CONTROLLER	TB1	TERMINAL BLOCK
F912	FUSE (250V 3.15A)	R64	RESISTOR	TB2	TERMINAL BLOCK
HC932	FET ARRAY	R934A, B	RESISTOR	X64	RELAY
IPM	POWER TRANSISTOR MODULE	RS1-4	RESISTOR	21S4	R.V. COIL
L	REACTOR	RT61	DISCHARGE TEMPERATURE THERMISTOR		
LEV	EXPANSION VALVE COIL	RT62	DEFROST THERMISTOR		

MUZ-A26YV -E1

OUTDOOR UNIT

MODEL WIRING DIAGRAM

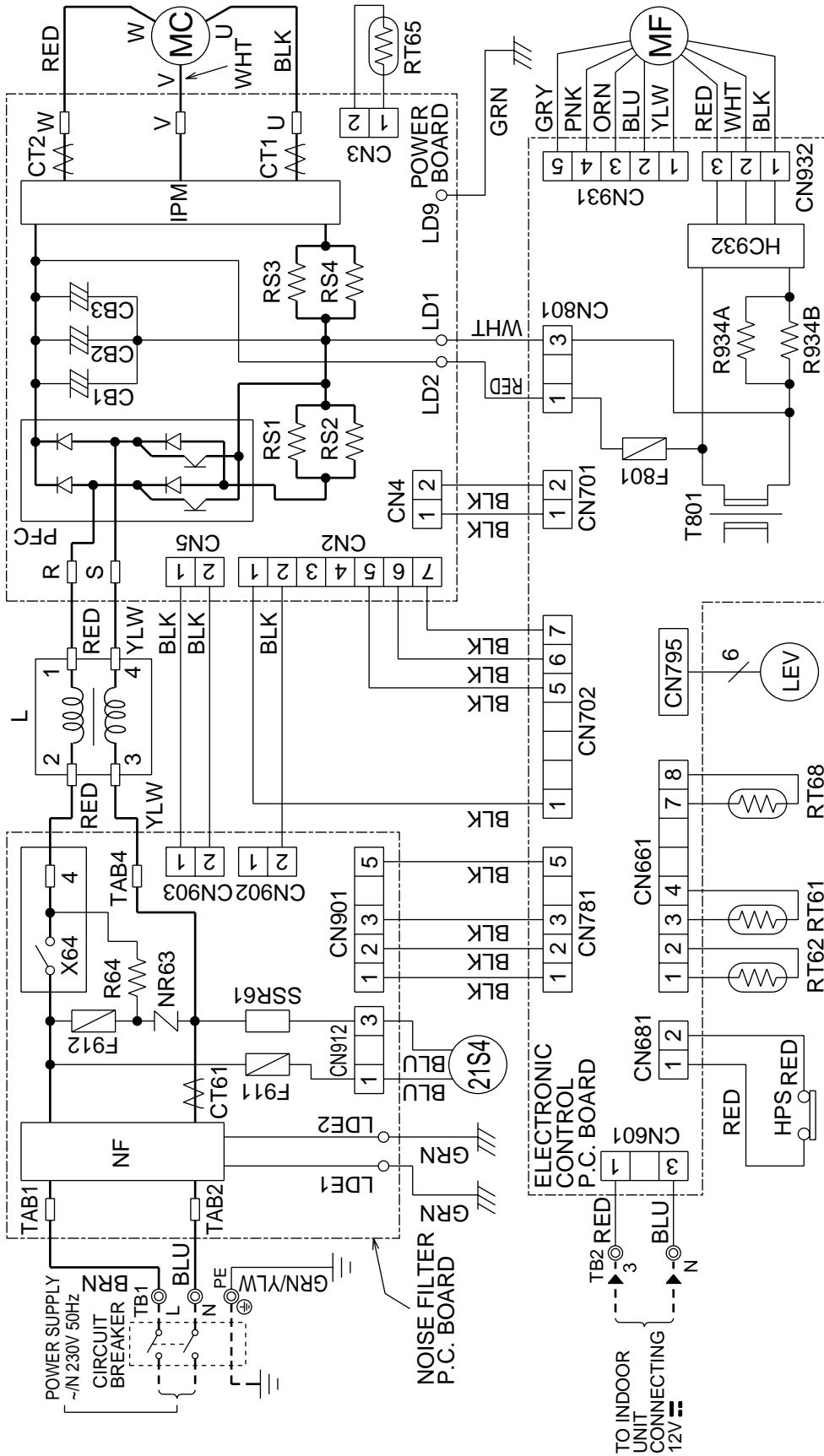

- NOTES: 1.About the indoor side electric wiring refer to the indoor unit electric wiring diagram for servicing.
 2.Use copper conductors only (for field wiring).
 3.Symbols below indicate.
 ⊙:Terminal block □:Connector

SYMBOL	NAME	SYMBOL	NAME	SYMBOL	NAME
MC	SMOOTHING CAPACITOR	MC	COMPRESSOR	RT68	OUTDOOR HEAT EXCHANGER TEMPERATURE THERMISTOR
MF	CURRENT TRANSFORMER	MF	OUTDOOR FAN MOTOR (INNER FUSE)	SSR61	SOLENOID COIL RELAY
NF	CURRENT TRANSFORMER	NF	NOISE FILTER	T801	TRANSFORMER
NR63	FUSE (250V 3.15A)	NR63	VARISTOR	TB1	TERMINAL BLOCK
F911	FUSE (250V 1A)	PFC	POWER FACTOR CONTROLLER	TB2	TERMINAL BLOCK
F912	FUSE (250V 3.15A)	R64	RESISTOR	X64	RELAY
HC932	FET ARRAY	R934A, B	RESISTOR	21S4	R.V. COIL
HPS	HIGH PRESSURE SWITCH	RS1-4	RESISTOR		
IPM	POWER TRANSISTOR MODULE	RT61	DISCHARGE TEMPERATURE THERMISTOR		
L	REACTOR	RT62	DEFROST THERMISTOR		
LEV	EXPANSION VALVE COIL	RT65	FIN TEMPERATURE THERMISTOR		

MUZ-A18YV -[E1]

MUZ-A24YV -[E1]

Unit:mm

OUTDOOR UNIT

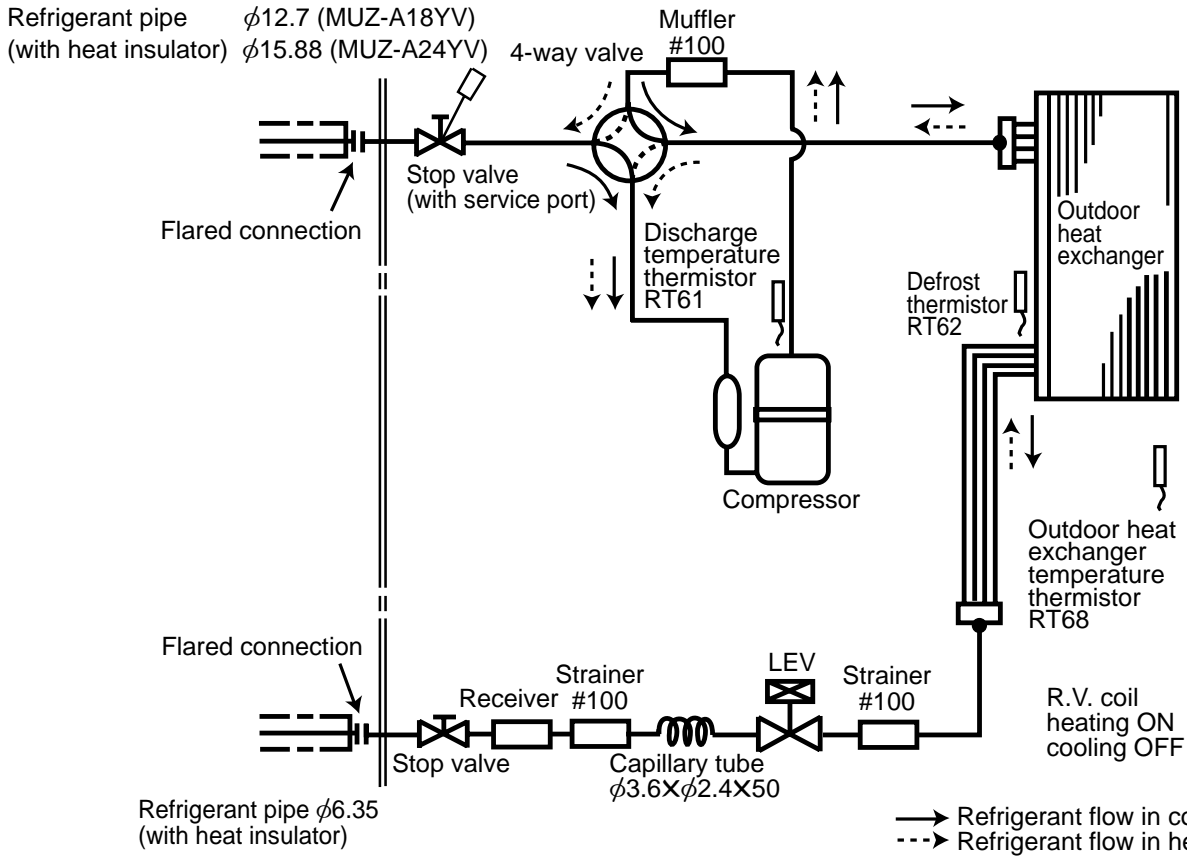

MUZ-A26YV -[E1]

OUTDOOR UNIT

Unit:mm

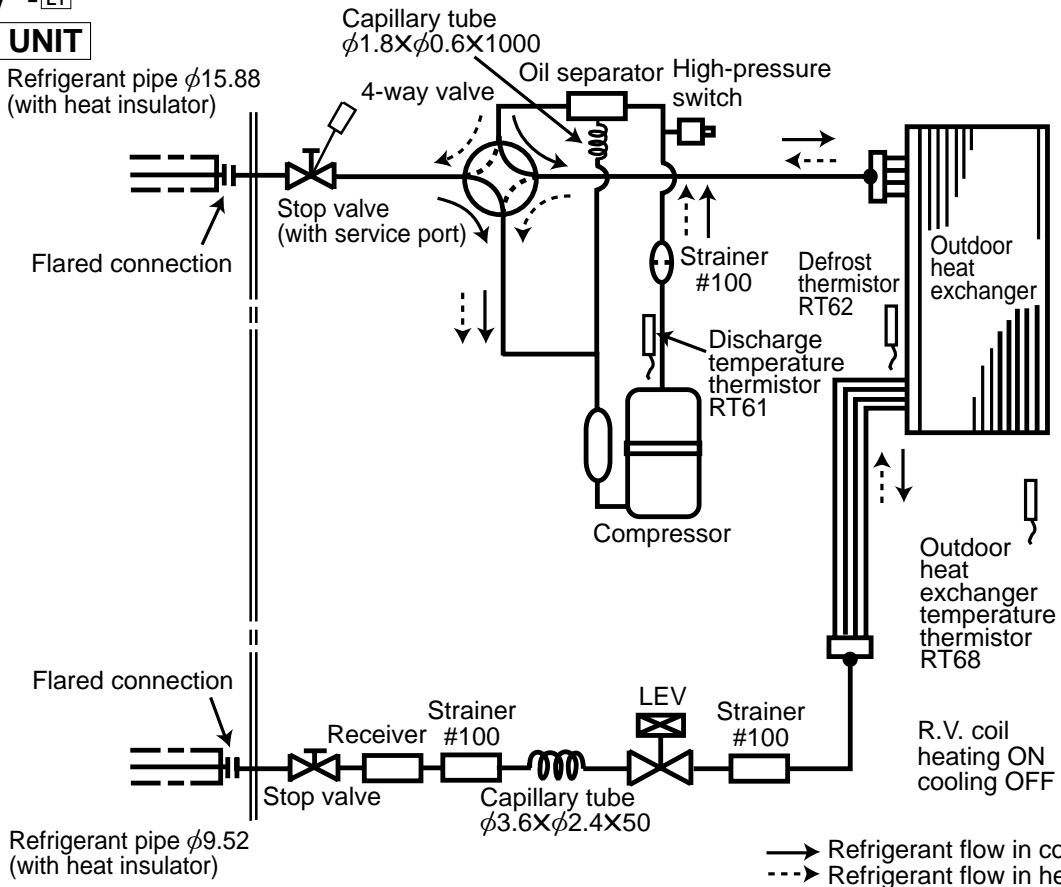

MAX. REFRIGERANT PIPING LENGTH

Model	Refrigerant piping Max. length : m A	Piping size O.D : mm		Length of connecting pipe : m	
		Gas	Liquid	Indoor unit	Outdoor unit
MUZ-A18YV - [E1]	30	12.7	6.35	Gas 0.43 Liquid 0.5	Gas 0 Liquid 0
MUZ-A24YV - [E1]		15.88			
MUZ-A26YV - [E1]			9.52		

MAX. HEIGHT DIFFERENCE

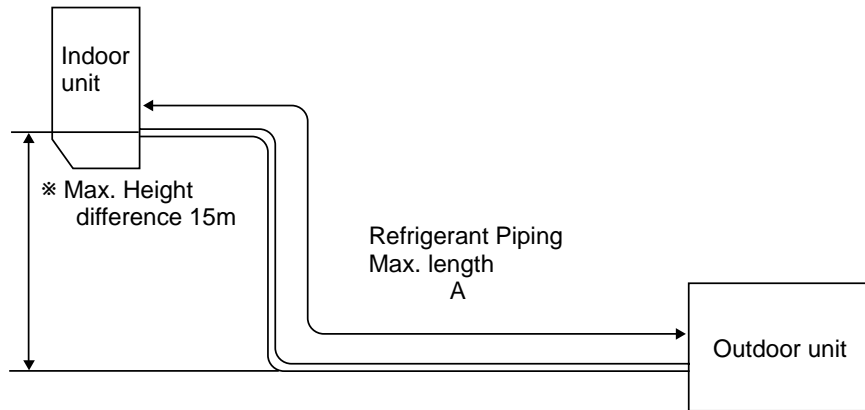

※ Height difference should be within 15m regardless of which unit, indoor or outdoor position is high.

ADDITIONAL REFRIGERANT CHARGE(R410A : g)

Model	Outdoor unit precharged	Refrigerant piping length (one way)					
		7m	10m	15m	20m	25m	30m
MUZ-A18YV - [E1]	1,800	0	60	160	260	360	460

Calculation : $Xg=20g/m \times (\text{Refrigerant piping length (m)}-7)$

Model	Outdoor unit precharged	Refrigerant piping length (one way)					
		7m	10m	15m	20m	25m	30m
MUZ-A24YV - [E1]	1,800	0	60	160	260	360	460

Calculation : $Xg=20g/m \times (\text{Refrigerant piping length (m)}-7)$

Model	Outdoor unit precharged	Refrigerant piping length (one way)					
		7m	10m	15m	20m	25m	30m
MUZ-A26YV - [E1]	2,000	0	165	440	715	990	1,265

Calculation : $Xg=55g/m \times (\text{Refrigerant piping length (m)}-7)$

MUZ-A18YV -E1**MUZ-A24YV** -E1**MUZ-A26YV** -E1

The standard data contained in these specifications apply only to the operation of the air conditioner under normal conditions. Since operating conditions vary according to the areas where these units are installed. The following information has been provided to clarify the operating characteristics of the air conditioner under the conditions indicated by the performance curve.

(1) GUARANTEED VOLTAGE

207 ~ 253V, 50Hz

(2) AIR FLOW

Air flow should be set at MAX.

(3) MAIN READINGS

(1) Indoor intake air wet-bulb temperature :	°C WB	} Cooling
(2) Indoor outlet air wet-bulb temperature :	°C WB	
(3) Outdoor intake air dry-bulb temperature :	°C DB	
(4) Total input :	W	} Heating
(5) Indoor intake air dry-bulb temperature :	°C DB	
(6) Outdoor intake air wet-bulb temperature :	°C WB	
(7) Total input :	W	

Indoor air wet/dry-bulb temperature difference on the left side of the chart on this page and next page shows the difference between the indoor intake air wet/dry-bulb temperature and the indoor outlet air wet/dry-bulb temperature for your reference at service.

How to measure the indoor air wet-bulb / dry-bulb temperature difference

1. Attach at least 2 sets of wet and dry-bulb thermometers to the indoor air intake as shown in the figure, and at least 2 sets of wet and dry-bulb thermometers to the indoor air outlet. The thermometers must be attached to the position where air speed is high.
2. Attach at least 2 sets of wet and dry-bulb thermometers to the outdoor air intake. Cover the thermometers to prevent direct rays of the sun.
3. Check that the air filter is cleaned.
4. Open windows and doors of room.
5. Press the EMERGENCY OPERATION switch once (twice) to start the EMERGENCY COOL (HEAT) MODE.
6. When system stabilizes after more than 15 minutes, measure temperature and take an average temperature.
7. 10 minutes later, measure temperature again and check that the temperature does not change.

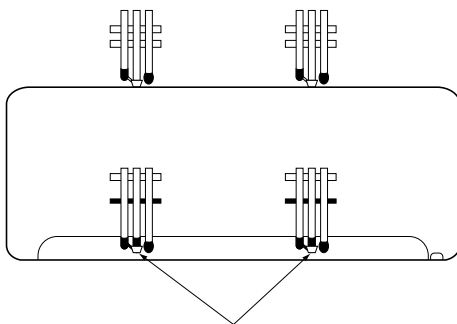
INDOOR UNIT

Wet and dry-bulb thermometers
FRONT VIEW

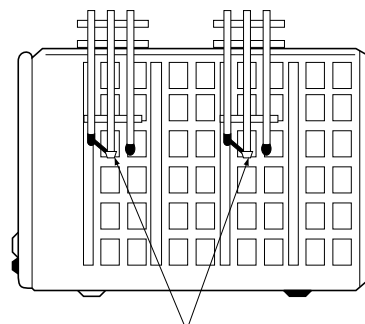
OUTDOOR UNIT

Wet and dry-bulb thermometers
BACK VIEW

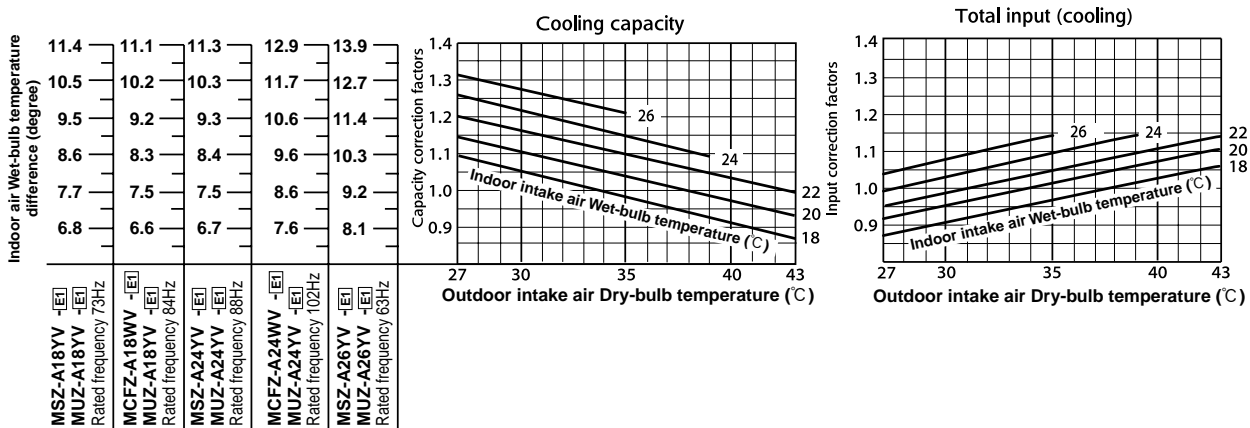

Indoor air Dry-bulb temperature difference (degree)	25.7	28.0	26.2	29.9	31.2
	23.7	25.9	24.1	27.6	28.8
	21.8	23.7	22.1	25.3	26.4
	19.8	21.6	20.1	23.0	24.0
	17.8	19.4	18.1	20.7	21.6
	15.8	17.2	16.1	18.4	19.2
	13.8	15.1	14.1	16.1	16.8
	11.9	12.9	12.1	13.8	14.4
	MSZ-A18YV -[E1] Rated frequency 82Hz	MCFZ-A18WV -[E1] Rated frequency 80Hz	MSZ-A24YV -[E1] Rated frequency 96Hz	MCFZ-A24WV -[E1] Rated frequency 95Hz	MSZ-A26YV -[E1] Rated frequency 65Hz

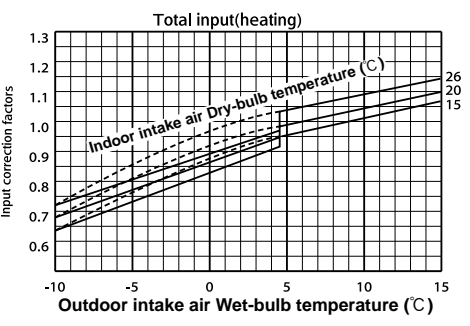
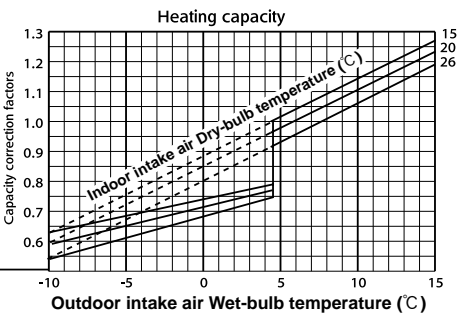

NOTE: The above curves are for the heating operation without any frost.

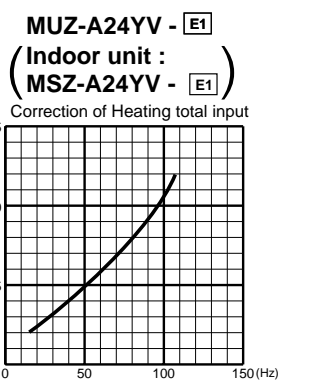
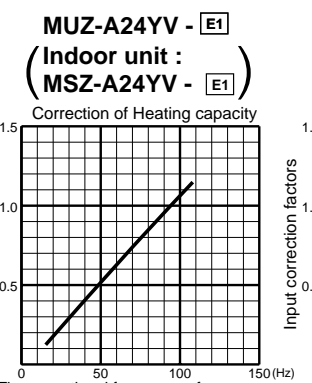
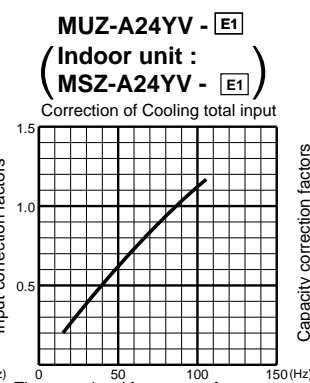
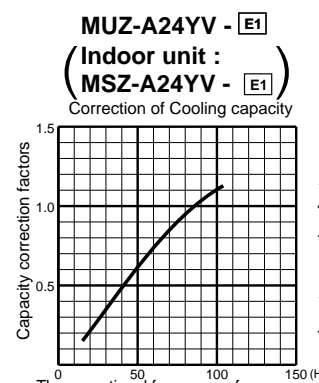
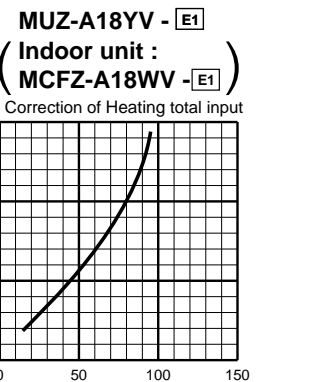
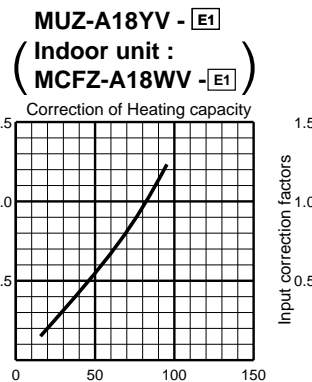
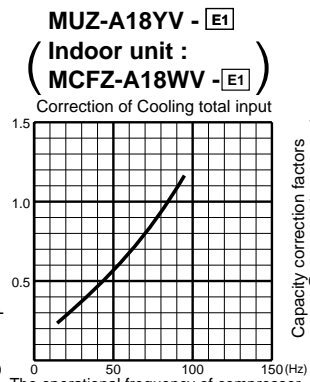
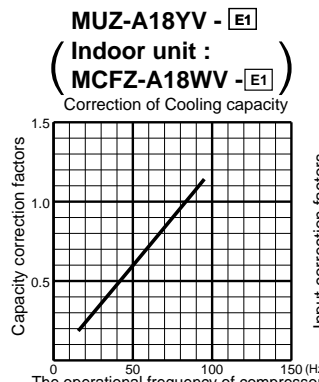
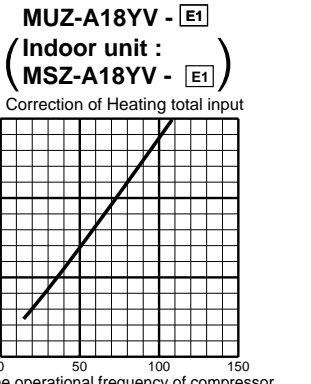
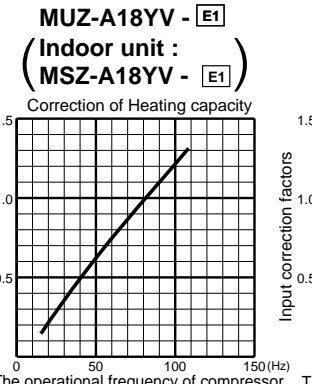
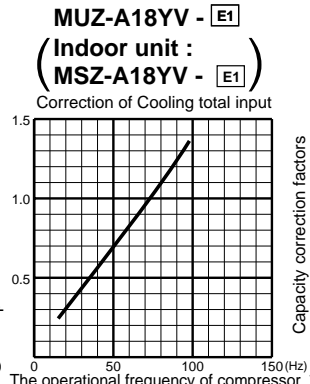
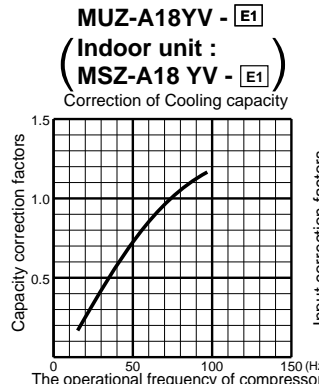

MUZ-A24YV - [E1]
(Indoor unit : MCFZ-A24WV - [E1])
 Correction of Cooling capacity

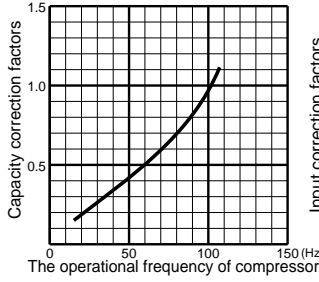

MUZ-A24YV - [E1]
(Indoor unit : MCFZ-A24WV - [E1])
 Correction of Cooling total input

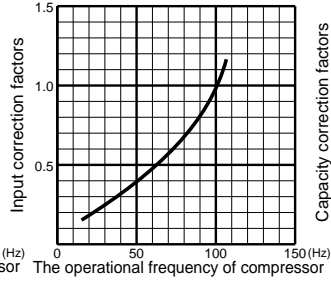

MUZ-A24YV - [E1]
(Indoor unit : MCFZ-A24WV - [E1])
 Correction of Heating capacity

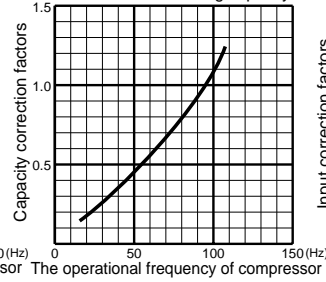

MUZ-A24YV - [E1]
(Indoor unit : MCFZ-A24WV - [E1])
 Correction of Heating total input

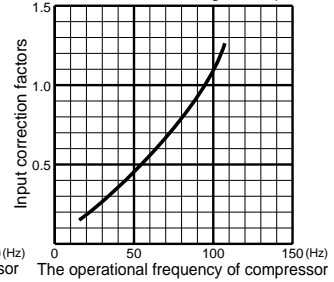

MUZ-A26YV - [E1]
 Correction of Cooling capacity

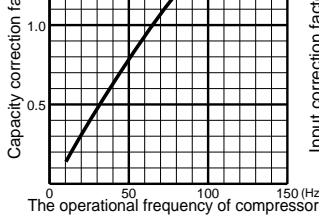

MUZ-A26YV - [E1]
 Correction of Cooling total input

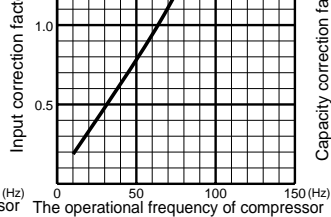

MUZ-A26YV - [E1]
 Correction of Heating capacity

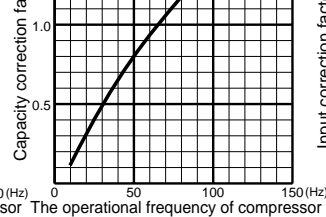

MUZ-A26YV - [E1]
 Correction of Heating total input

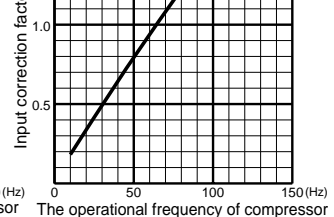

OUTDOOR LOW PRESSURE AND OUTDOOR UNIT CURRENT

<How to operate fixed-frequency operation (Test run operation)>

1. Press the EMERGENCY OPERATION switch to COOL or HEAT mode (COOL : Press once, HEAT : Press twice).
2. Test run operation starts and continue to operate for 30 minutes.
3. Compressor starts at fixed-frequency.
4. Indoor fan operates at High speed.
5. After 30 minutes, test run operation finishes and EMERGENCY OPERATION starts.
6. To cancel test run operation (EMERGENCY OPERATION), press the EMERGENCY OPERATION switch or any button on remote controller.

NOTE : The unit of pressure has been changed to MPa on the international system of units (SI unit system).
 The conversion factor is: **1(MPa [Gauge]) = 10.2(kgf/cm² [Gauge])**

OUTDOOR LOW PRESSURE AND OUTDOOR UNIT CURRENT

COOL operation

- ① Both indoor and outdoor unit are under the same temperature/humidity condition.
- ② Air flow : High speed
- ③ Operational frequency : 25Hz(MUZ-A18YV)
 25Hz(MUZ-A24YV)
 24Hz(MUZ-A26YV)

Dry-bulb temperature	Relative humidity(%)
20	50
25	60
30	70

MUZ-A18YV - [E1]
(Indoor unit : MSZ-A18YV - [E1])

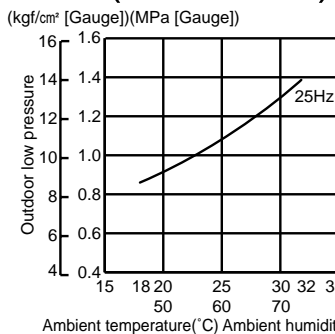

MUZ-A18YV - [E1]
(Indoor unit : MSZ-A18YV - [E1])

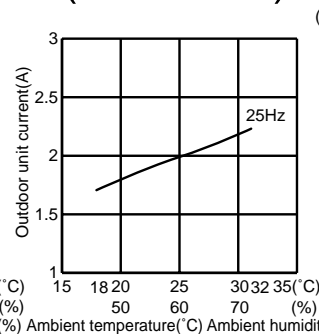

MUZ-A18YV - [E1]
(Indoor unit : MCFZ-A18WV - [E1])

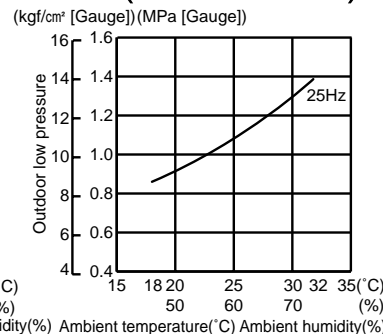

MUZ-A18YV - [E1]
(Indoor unit : MCFZ-A18WV - [E1])

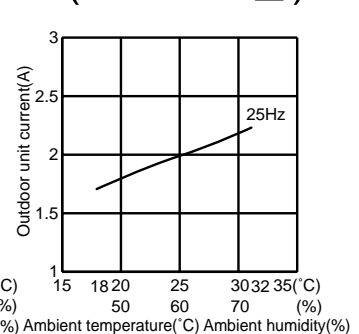



MUZ-A24YV - [E1]
(Indoor unit : MSZ-A24YV - [E1])

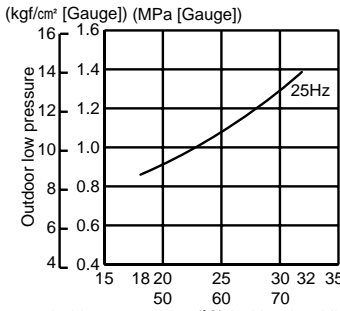

MUZ-A24YV - [E1]
(Indoor unit : MSZ-A24YV - [E1])

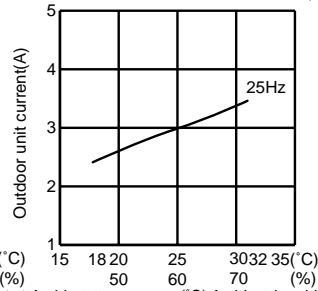

MUZ-A24YV - [E1]
(Indoor unit : MCFZ-A24YV - [E1])

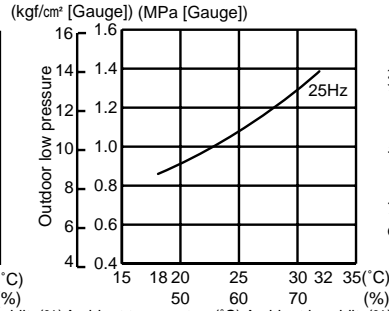

MUZ-A24YV - [E1]
(Indoor unit : MCFZ-A24YV - [E1])

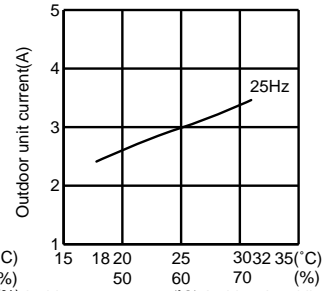

Ambient temperature(°C) Ambient humidity(%) Ambient temperature(°C) Ambient humidity(%) Ambient temperature(°C) Ambient humidity(%) Ambient temperature(°C) Ambient humidity(%)

MUZ-A26YV - [E1]

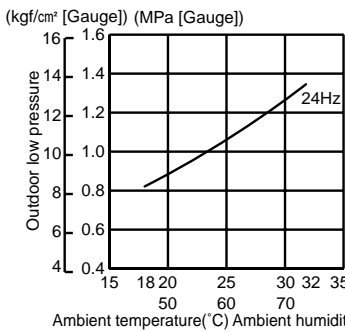

MUZ-A26YV - [E1]

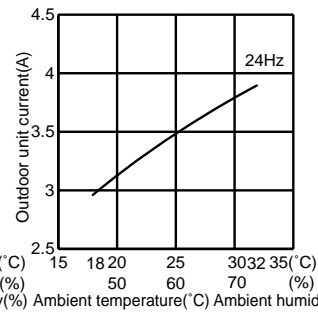

Ambient temperature(°C) Ambient humidity(%) Ambient temperature(°C) Ambient humidity(%)

HEAT operation

Condition indoor: Dry bulb temperature 20.0°C
 Wet bulb temperature 14.5°C
 Condition outdoor: Dry bulb temperature 2,7,15,20.0°C
 Wet bulb temperature 1,6,12,14.5°C

Operational frequency : 32Hz(MUZ-A18YV)
 32Hz(MUZ-A24YV)
 32Hz(MUZ-A26YV)

MUZ-A18YV - [E1]
(Indoor unit : MSZ-A18YV - [E1])

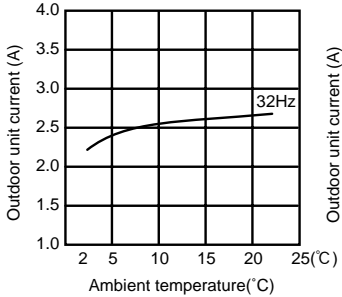

MUZ-A18YV - [E1]
(Indoor unit : MCFZ-A18WV - [E1])

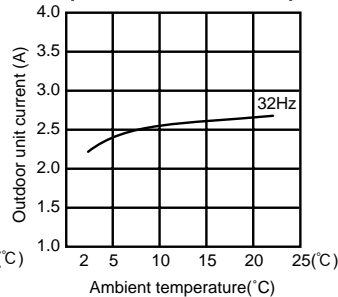

MUZ-A24YV - [E1]
(Indoor unit : MSZ-A24YV - [E1])

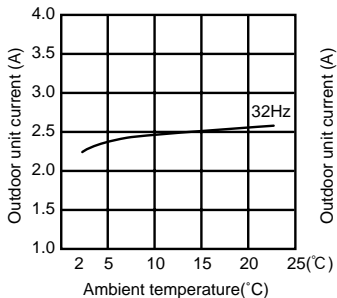

MUZ-A24YV - [E1]
(Indoor unit : MCFZ-A24WV - [E1])

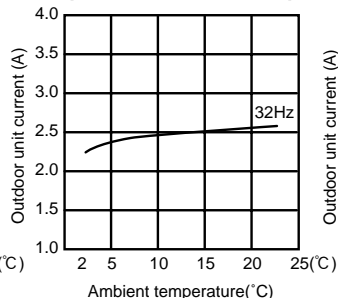

MUZ-A26YV - [E1]

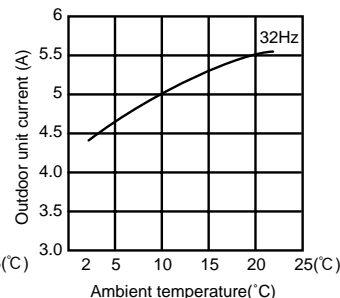

PERFORMANCE DATA COOL operation Rated frequency 73Hz

MSZ-A18YV -[E1] : MUZ-A18YV -[E1]

CAPACITY:5.0(kW) SHF:0.65 INPUT:1560(W)

		OUTDOOR DB(°C)															
INDOOR DB(°C)	INDOOR WB(°C)	21				25				27				30			
		Q	SHC	SHF	INPUT	Q	SHC	SHF	INPUT	Q	SHC	SHF	INPUT	Q	SHC	SHF	INPUT
21	18	5.88	2.76	0.47	1248	5.63	2.64	0.47	1310	5.40	2.54	0.47	1373	5.20	2.44	0.47	1435
21	20	6.13	2.14	0.35	1310	5.88	2.06	0.35	1388	5.70	2.00	0.35	1420	5.50	1.93	0.35	1482
22	18	5.88	3.00	0.51	1248	5.63	2.87	0.51	1310	5.40	2.75	0.51	1373	5.20	2.65	0.51	1435
22	20	6.13	2.39	0.39	1310	5.88	2.29	0.39	1388	5.70	2.22	0.39	1420	5.50	2.15	0.39	1482
22	22	6.38	1.72	0.27	1357	6.15	1.66	0.27	1443	6.00	1.62	0.27	1482	5.75	1.55	0.27	1544
23	18	5.88	3.23	0.55	1248	5.63	3.09	0.55	1310	5.40	2.97	0.55	1373	5.20	2.86	0.55	1435
23	20	6.13	2.63	0.43	1310	5.88	2.53	0.43	1388	5.70	2.45	0.43	1420	5.50	2.37	0.43	1482
23	22	6.38	1.98	0.31	1357	6.15	1.91	0.31	1443	6.00	1.86	0.31	1482	5.75	1.78	0.31	1544
24	18	5.88	3.47	0.59	1248	5.63	3.32	0.59	1310	5.40	3.19	0.59	1373	5.20	3.07	0.59	1435
24	20	6.13	2.88	0.47	1310	5.88	2.76	0.47	1388	5.70	2.68	0.47	1420	5.50	2.59	0.47	1482
24	22	6.38	2.23	0.35	1357	6.15	2.15	0.35	1443	6.00	2.10	0.35	1482	5.75	2.01	0.35	1544
24	24	6.70	1.54	0.23	1420	6.45	1.48	0.23	1498	6.30	1.45	0.23	1544	6.10	1.40	0.23	1622
25	18	5.88	3.70	0.63	1248	5.63	3.54	0.63	1310	5.40	3.40	0.63	1373	5.20	3.28	0.63	1435
25	20	6.13	3.12	0.51	1310	5.88	3.00	0.51	1388	5.70	2.91	0.51	1420	5.50	2.81	0.51	1482
25	22	6.38	2.49	0.39	1357	6.15	2.40	0.39	1443	6.00	2.34	0.39	1482	5.75	2.24	0.39	1544
25	24	6.70	1.81	0.27	1420	6.45	1.74	0.27	1498	6.30	1.70	0.27	1544	6.10	1.65	0.27	1622
26	18	5.88	3.94	0.67	1248	5.63	3.77	0.67	1310	5.40	3.62	0.67	1373	5.20	3.48	0.67	1435
26	20	6.13	3.37	0.55	1310	5.88	3.23	0.55	1388	5.70	3.14	0.55	1420	5.50	3.03	0.55	1482
26	22	6.38	2.74	0.43	1357	6.15	2.64	0.43	1443	6.00	2.58	0.43	1482	5.75	2.47	0.43	1544
26	24	6.70	2.08	0.31	1420	6.45	2.00	0.31	1498	6.30	1.95	0.31	1544	6.10	1.89	0.31	1622
26	26	6.90	1.31	0.19	1498	6.70	1.27	0.19	1576	6.60	1.25	0.19	1622	6.40	1.22	0.19	1669
27	18	5.88	4.17	0.71	1248	5.63	3.99	0.71	1310	5.40	3.83	0.71	1373	5.20	3.69	0.71	1435
27	20	6.13	3.61	0.59	1310	5.88	3.47	0.59	1388	5.70	3.36	0.59	1420	5.50	3.25	0.59	1482
27	22	6.38	3.00	0.47	1357	6.15	2.89	0.47	1443	6.00	2.82	0.47	1482	5.75	2.70	0.47	1544
27	24	6.70	2.35	0.35	1420	6.45	2.26	0.35	1498	6.30	2.21	0.35	1544	6.10	2.14	0.35	1622
27	26	6.90	1.59	0.23	1498	6.70	1.54	0.23	1576	6.60	1.52	0.23	1622	6.40	1.47	0.23	1669
28	18	5.88	4.41	0.75	1248	5.63	4.22	0.75	1310	5.40	4.05	0.75	1373	5.20	3.90	0.75	1435
28	20	6.13	3.86	0.63	1310	5.88	3.70	0.63	1388	5.70	3.59	0.63	1420	5.50	3.47	0.63	1482
28	22	6.38	3.25	0.51	1357	6.15	3.14	0.51	1443	6.00	3.06	0.51	1482	5.75	2.93	0.51	1544
28	24	6.70	2.61	0.39	1420	6.45	2.52	0.39	1498	6.30	2.46	0.39	1544	6.10	2.38	0.39	1622
28	26	6.90	1.86	0.27	1498	6.70	1.81	0.27	1576	6.60	1.78	0.27	1622	6.40	1.73	0.27	1669
29	18	5.88	4.64	0.79	1248	5.63	4.44	0.79	1310	5.40	4.27	0.79	1373	5.20	4.11	0.79	1435
29	20	6.13	4.10	0.67	1310	5.88	3.94	0.67	1388	5.70	3.82	0.67	1420	5.50	3.69	0.67	1482
29	22	6.38	3.51	0.55	1357	6.15	3.38	0.55	1443	6.00	3.30	0.55	1482	5.75	3.16	0.55	1544
29	24	6.70	2.88	0.43	1420	6.45	2.77	0.43	1498	6.30	2.71	0.43	1544	6.10	2.62	0.43	1622
29	26	6.90	2.14	0.31	1498	6.70	2.08	0.31	1576	6.60	2.05	0.31	1622	6.40	1.98	0.31	1669
30	18	5.88	4.88	0.83	1248	5.63	4.67	0.83	1310	5.40	4.48	0.83	1373	5.20	4.32	0.83	1435
30	20	6.13	4.35	0.71	1310	5.88	4.17	0.71	1388	5.70	4.05	0.71	1420	5.50	3.91	0.71	1482
30	22	6.38	3.76	0.59	1357	6.15	3.63	0.59	1443	6.00	3.54	0.59	1482	5.75	3.39	0.59	1544
30	24	6.70	3.15	0.47	1420	6.45	3.03	0.47	1498	6.30	2.96	0.47	1544	6.10	2.87	0.47	1622
30	26	6.90	2.42	0.35	1498	6.70	2.35	0.35	1576	6.60	2.31	0.35	1622	6.40	2.24	0.35	1669
31	18	5.88	5.11	0.87	1248	5.63	4.89	0.87	1310	5.40	4.70	0.87	1373	5.20	4.52	0.87	1435
31	20	6.13	4.59	0.75	1310	5.88	4.41	0.75	1388	5.70	4.28	0.75	1420	5.50	4.13	0.75	1482
31	22	6.38	4.02	0.63	1357	6.15	3.87	0.63	1443	6.00	3.78	0.63	1482	5.75	3.62	0.63	1544
31	24	6.70	3.42	0.51	1420	6.45	3.29	0.51	1498	6.30	3.21	0.51	1544	6.10	3.11	0.51	1622
31	26	6.90	2.69	0.39	1498	6.70	2.61	0.39	1576	6.60	2.57	0.39	1622	6.40	2.50	0.39	1669
32	18	5.88	5.35	0.91	1248	5.63	5.12	0.91	1310	5.40	4.91	0.91	1373	5.20	4.73	0.91	1435
32	20	6.13	4.84	0.79	1310	5.88	4.64	0.79	1388	5.70	4.50	0.79	1420	5.50	4.35	0.79	1482
32	22	6.38	4.27	0.67	1357	6.15	4.12	0.67	1443	6.00	4.02	0.67	1482	5.75	3.85	0.67	1544
32	24	6.70	3.69	0.55	1420	6.45	3.55	0.55	1498	6.30	3.47	0.55	1544	6.10	3.36	0.55	1622
32	26	6.90	2.97	0.43	1498	6.70	2.88	0.43	1576	6.60	2.84	0.43	1622	6.40	2.75	0.43	1669

NOTE Q : Total capacity (kW) SHF : Sensible heat factor DB : Dry-bulb temperature
 SHC : Sensible heat capacity (kW) INPUT : Total power input (W) WB : Wet-bulb temperature

PERFORMANCE DATA COOL operation Rated frequency 73Hz

MSZ-A18YV -[E1] : MUZ-A18YV -[E1]

CAPACITY : 5.0(kW) SHF : 0.65 INPUT : 1560(W)

		OUTDOOR DB(°C)											
INDOOR DB(°C)	INDOOR WB(°C)	35				40				43			
		Q	SHC	SHF	INPUT	Q	SHC	SHF	INPUT	Q	SHC	SHF	INPUT
21	18	4.90	2.30	0.47	1529	4.50	2.12	0.47	1622	4.33	2.03	0.47	1654
21	20	5.15	1.80	0.35	1591	4.80	1.68	0.35	1669	4.63	1.62	0.35	1716
22	18	4.90	2.50	0.51	1529	4.50	2.30	0.51	1622	4.33	2.21	0.51	1654
22	20	5.15	2.01	0.39	1591	4.80	1.87	0.39	1669	4.63	1.80	0.39	1716
22	22	5.45	1.47	0.27	1654	5.10	1.38	0.27	1747	4.93	1.33	0.27	1778
23	18	4.90	2.70	0.55	1529	4.50	2.48	0.55	1622	4.33	2.38	0.55	1654
23	20	5.15	2.21	0.43	1591	4.80	2.06	0.43	1669	4.63	1.99	0.43	1716
23	22	5.45	1.69	0.31	1654	5.10	1.58	0.31	1747	4.93	1.53	0.31	1778
24	18	4.90	2.89	0.59	1529	4.50	2.66	0.59	1622	4.33	2.55	0.59	1654
24	20	5.15	2.42	0.47	1591	4.80	2.26	0.47	1669	4.63	2.17	0.47	1716
24	22	5.45	1.91	0.35	1654	5.10	1.79	0.35	1747	4.93	1.72	0.35	1778
24	24	5.75	1.32	0.23	1716	5.40	1.24	0.23	1794	5.25	1.21	0.23	1833
25	18	4.90	3.09	0.63	1529	4.50	2.84	0.63	1622	4.33	2.72	0.63	1654
25	20	5.15	2.63	0.51	1591	4.80	2.45	0.51	1669	4.63	2.36	0.51	1716
25	22	5.45	2.13	0.39	1654	5.10	1.99	0.39	1747	4.93	1.92	0.39	1778
25	24	5.75	1.55	0.27	1716	5.40	1.46	0.27	1794	5.25	1.42	0.27	1833
26	18	4.90	3.28	0.67	1529	4.50	3.02	0.67	1622	4.33	2.90	0.67	1654
26	20	5.15	2.83	0.55	1591	4.80	2.64	0.55	1669	4.63	2.54	0.55	1716
26	22	5.45	2.34	0.43	1654	5.10	2.19	0.43	1747	4.93	2.12	0.43	1778
26	24	5.75	1.78	0.31	1716	5.40	1.67	0.31	1794	5.25	1.63	0.31	1833
26	26	6.05	1.15	0.19	1778	5.70	1.08	0.19	1856	5.53	1.05	0.19	1895
27	18	4.90	3.48	0.71	1529	4.50	3.20	0.71	1622	4.33	3.07	0.71	1654
27	20	5.15	3.04	0.59	1591	4.80	2.83	0.59	1669	4.63	2.73	0.59	1716
27	22	5.45	2.56	0.47	1654	5.10	2.40	0.47	1747	4.93	2.31	0.47	1778
27	24	5.75	2.01	0.35	1716	5.40	1.89	0.35	1794	5.25	1.84	0.35	1833
27	26	6.05	1.39	0.23	1778	5.70	1.31	0.23	1856	5.53	1.27	0.23	1895
28	18	4.90	3.68	0.75	1529	4.50	3.38	0.75	1622	4.33	3.24	0.75	1654
28	20	5.15	3.24	0.63	1591	4.80	3.02	0.63	1669	4.63	2.91	0.63	1716
28	22	5.45	2.78	0.51	1654	5.10	2.60	0.51	1747	4.93	2.51	0.51	1778
28	24	5.75	2.24	0.39	1716	5.40	2.11	0.39	1794	5.25	2.05	0.39	1833
28	26	6.05	1.63	0.27	1778	5.70	1.54	0.27	1856	5.53	1.49	0.27	1895
29	18	4.90	3.87	0.79	1529	4.50	3.56	0.79	1622	4.33	3.42	0.79	1654
29	20	5.15	3.45	0.67	1591	4.80	3.22	0.67	1669	4.63	3.10	0.67	1716
29	22	5.45	3.00	0.55	1654	5.10	2.81	0.55	1747	4.93	2.71	0.55	1778
29	24	5.75	2.47	0.43	1716	5.40	2.32	0.43	1794	5.25	2.26	0.43	1833
29	26	6.05	1.88	0.31	1778	5.70	1.77	0.31	1856	5.53	1.71	0.31	1895
30	18	4.90	4.07	0.83	1529	4.50	3.74	0.83	1622	4.33	3.59	0.83	1654
30	20	5.15	3.66	0.71	1591	4.80	3.41	0.71	1669	4.63	3.28	0.71	1716
30	22	5.45	3.22	0.59	1654	5.10	3.01	0.59	1747	4.93	2.91	0.59	1778
30	24	5.75	2.70	0.47	1716	5.40	2.54	0.47	1794	5.25	2.47	0.47	1833
30	26	6.05	2.12	0.35	1778	5.70	2.00	0.35	1856	5.53	1.93	0.35	1895
31	18	4.90	4.26	0.87	1529	4.50	3.92	0.87	1622	4.33	3.76	0.87	1654
31	20	5.15	3.86	0.75	1591	4.80	3.60	0.75	1669	4.63	3.47	0.75	1716
31	22	5.45	3.43	0.63	1654	5.10	3.21	0.63	1747	4.93	3.10	0.63	1778
31	24	5.75	2.93	0.51	1716	5.40	2.75	0.51	1794	5.25	2.68	0.51	1833
31	26	6.05	2.36	0.39	1778	5.70	2.22	0.39	1856	5.53	2.15	0.39	1895
32	18	4.90	4.46	0.91	1529	4.50	4.10	0.91	1622	4.33	3.94	0.91	1654
32	20	5.15	4.07	0.79	1591	4.80	3.79	0.79	1669	4.63	3.65	0.79	1716
32	22	5.45	3.65	0.67	1654	5.10	3.42	0.67	1747	4.93	3.30	0.67	1778
32	24	5.75	3.16	0.55	1716	5.40	2.97	0.55	1794	5.25	2.89	0.55	1833
32	26	6.05	2.60	0.43	1778	5.70	2.45	0.43	1856	5.53	2.38	0.43	1895

NOTE Q : Total capacity (kW) SHF : Sensible heat factor DB : Dry-bulb temperature
 SHC : Sensible heat capacity (kW) INPUT : Total power input (W) WB : Wet-bulb temperature

PERFORMANCE DATA COOL operation Rated frequency 84Hz

MCFZ-A18WV -[E1] : MUZ-A18YV -[E1]

CAPACITY:4.8(kW) SHF:0.65 INPUT:1830(W)

		OUTDOOR DB(°C)															
INDOOR DB(°C)	INDOOR WB(°C)	21				25				27				30			
		Q	SHC	SHF	INPUT	Q	SHC	SHF	INPUT	Q	SHC	SHF	INPUT	Q	SHC	SHF	INPUT
21	18	5.64	2.65	0.47	1464	5.40	2.54	0.47	1537	5.18	2.44	0.47	1610	4.99	2.35	0.47	1684
21	20	5.88	2.06	0.35	1537	5.64	1.97	0.35	1629	5.47	1.92	0.35	1665	5.28	1.85	0.35	1739
22	18	5.64	2.88	0.51	1464	5.40	2.75	0.51	1537	5.18	2.64	0.51	1610	4.99	2.55	0.51	1684
22	20	5.88	2.29	0.39	1537	5.64	2.20	0.39	1629	5.47	2.13	0.39	1665	5.28	2.06	0.39	1739
22	22	6.12	1.65	0.27	1592	5.90	1.59	0.27	1693	5.76	1.56	0.27	1739	5.52	1.49	0.27	1812
23	18	5.64	3.10	0.55	1464	5.40	2.97	0.55	1537	5.18	2.85	0.55	1610	4.99	2.75	0.55	1684
23	20	5.88	2.53	0.43	1537	5.64	2.43	0.43	1629	5.47	2.35	0.43	1665	5.28	2.27	0.43	1739
23	22	6.12	1.90	0.31	1592	5.90	1.83	0.31	1693	5.76	1.79	0.31	1739	5.52	1.71	0.31	1812
24	18	5.64	3.33	0.59	1464	5.40	3.19	0.59	1537	5.18	3.06	0.59	1610	4.99	2.95	0.59	1684
24	20	5.88	2.76	0.47	1537	5.64	2.65	0.47	1629	5.47	2.57	0.47	1665	5.28	2.48	0.47	1739
24	22	6.12	2.14	0.35	1592	5.90	2.07	0.35	1693	5.76	2.02	0.35	1739	5.52	1.93	0.35	1812
24	24	6.43	1.48	0.23	1665	6.19	1.42	0.23	1757	6.05	1.39	0.23	1812	5.86	1.35	0.23	1903
25	18	5.64	3.55	0.63	1464	5.40	3.40	0.63	1537	5.18	3.27	0.63	1610	4.99	3.14	0.63	1684
25	20	5.88	3.00	0.51	1537	5.64	2.88	0.51	1629	5.47	2.79	0.51	1665	5.28	2.69	0.51	1739
25	22	6.12	2.39	0.39	1592	5.90	2.30	0.39	1693	5.76	2.25	0.39	1739	5.52	2.15	0.39	1812
25	24	6.43	1.74	0.27	1665	6.19	1.67	0.27	1757	6.05	1.63	0.27	1812	5.86	1.58	0.27	1903
26	18	5.64	3.78	0.67	1464	5.40	3.62	0.67	1537	5.18	3.47	0.67	1610	4.99	3.34	0.67	1684
26	20	5.88	3.23	0.55	1537	5.64	3.10	0.55	1629	5.47	3.01	0.55	1665	5.28	2.90	0.55	1739
26	22	6.12	2.63	0.43	1592	5.90	2.54	0.43	1693	5.76	2.48	0.43	1739	5.52	2.37	0.43	1812
26	24	6.43	1.99	0.31	1665	6.19	1.92	0.31	1757	6.05	1.87	0.31	1812	5.86	1.82	0.31	1903
26	26	6.62	1.26	0.19	1757	6.43	1.22	0.19	1848	6.34	1.20	0.19	1903	6.14	1.17	0.19	1958
27	18	5.64	4.00	0.71	1464	5.40	3.83	0.71	1537	5.18	3.68	0.71	1610	4.99	3.54	0.71	1684
27	20	5.88	3.47	0.59	1537	5.64	3.33	0.59	1629	5.47	3.23	0.59	1665	5.28	3.12	0.59	1739
27	22	6.12	2.88	0.47	1592	5.90	2.77	0.47	1693	5.76	2.71	0.47	1739	5.52	2.59	0.47	1812
27	24	6.43	2.25	0.35	1665	6.19	2.17	0.35	1757	6.05	2.12	0.35	1812	5.86	2.05	0.35	1903
27	26	6.62	1.52	0.23	1757	6.43	1.48	0.23	1848	6.34	1.46	0.23	1903	6.14	1.41	0.23	1958
28	18	5.64	4.23	0.75	1464	5.40	4.05	0.75	1537	5.18	3.89	0.75	1610	4.99	3.74	0.75	1684
28	20	5.88	3.70	0.63	1537	5.64	3.55	0.63	1629	5.47	3.45	0.63	1665	5.28	3.33	0.63	1739
28	22	6.12	3.12	0.51	1592	5.90	3.01	0.51	1693	5.76	2.94	0.51	1739	5.52	2.82	0.51	1812
28	24	6.43	2.51	0.39	1665	6.19	2.41	0.39	1757	6.05	2.36	0.39	1812	5.86	2.28	0.39	1903
28	26	6.62	1.79	0.27	1757	6.43	1.74	0.27	1848	6.34	1.71	0.27	1903	6.14	1.66	0.27	1958
29	18	5.64	4.46	0.79	1464	5.40	4.27	0.79	1537	5.18	4.10	0.79	1610	4.99	3.94	0.79	1684
29	20	5.88	3.94	0.67	1537	5.64	3.78	0.67	1629	5.47	3.67	0.67	1665	5.28	3.54	0.67	1739
29	22	6.12	3.37	0.55	1592	5.90	3.25	0.55	1693	5.76	3.17	0.55	1739	5.52	3.04	0.55	1812
29	24	6.43	2.77	0.43	1665	6.19	2.66	0.43	1757	6.05	2.60	0.43	1812	5.86	2.52	0.43	1903
29	26	6.62	2.05	0.31	1757	6.43	1.99	0.31	1848	6.34	1.96	0.31	1903	6.14	1.90	0.31	1958
30	18	5.64	4.68	0.83	1464	5.40	4.48	0.83	1537	5.18	4.30	0.83	1610	4.99	4.14	0.83	1684
30	20	5.88	4.17	0.71	1537	5.64	4.00	0.71	1629	5.47	3.89	0.71	1665	5.28	3.75	0.71	1739
30	22	6.12	3.61	0.59	1592	5.90	3.48	0.59	1693	5.76	3.40	0.59	1739	5.52	3.26	0.59	1812
30	24	6.43	3.02	0.47	1665	6.19	2.91	0.47	1757	6.05	2.84	0.47	1812	5.86	2.75	0.47	1903
30	26	6.62	2.32	0.35	1757	6.43	2.25	0.35	1848	6.34	2.22	0.35	1903	6.14	2.15	0.35	1958
31	18	5.64	4.91	0.87	1464	5.40	4.70	0.87	1537	5.18	4.51	0.87	1610	4.99	4.34	0.87	1684
31	20	5.88	4.41	0.75	1537	5.64	4.23	0.75	1629	5.47	4.10	0.75	1665	5.28	3.96	0.75	1739
31	22	6.12	3.86	0.63	1592	5.90	3.72	0.63	1693	5.76	3.63	0.63	1739	5.52	3.48	0.63	1812
31	24	6.43	3.28	0.51	1665	6.19	3.16	0.51	1757	6.05	3.08	0.51	1812	5.86	2.99	0.51	1903
31	26	6.62	2.58	0.39	1757	6.43	2.51	0.39	1848	6.34	2.47	0.39	1903	6.14	2.40	0.39	1958
32	18	5.64	5.13	0.91	1464	5.40	4.91	0.91	1537	5.18	4.72	0.91	1610	4.99	4.54	0.91	1684
32	20	5.88	4.65	0.79	1537	5.64	4.46	0.79	1629	5.47	4.32	0.79	1665	5.28	4.17	0.79	1739
32	22	6.12	4.10	0.67	1592	5.90	3.96	0.67	1693	5.76	3.86	0.67	1739	5.52	3.70	0.67	1812
32	24	6.43	3.54	0.55	1665	6.19	3.41	0.55	1757	6.05	3.33	0.55	1812	5.86	3.22	0.55	1903
32	26	6.62	2.85	0.43	1757	6.43	2.77	0.43	1848	6.34	2.72	0.43	1903	6.14	2.64	0.43	1958

NOTE Q : Total capacity (kW) SHF : Sensible heat factor DB : Dry-bulb temperature
 SHC : Sensible heat capacity (kW) INPUT : Total power input (W) WB : Wet-bulb temperature

PERFORMANCE DATA COOL operation Rated frequency 84Hz

MCFZ-A18WV -[E1] : MUZ-A18YV -[E1]

CAPACITY : 4.8(kW) SHF : 0.65 INPUT : 1830(W)

		OUTDOOR DB(°C)											
INDOOR DB(°C)	INDOOR WB(°C)	35				40				43			
		Q	SHC	SHF	INPUT	Q	SHC	SHF	INPUT	Q	SHC	SHF	INPUT
21	18	4.70	2.21	0.47	1793	4.32	2.03	0.47	1903	4.15	1.95	0.47	1940
21	20	4.94	1.73	0.35	1867	4.61	1.61	0.35	1958	4.44	1.55	0.35	2013
22	18	4.70	2.40	0.51	1793	4.32	2.20	0.51	1903	4.15	2.12	0.51	1940
22	20	4.94	1.93	0.39	1867	4.61	1.80	0.39	1958	4.44	1.73	0.39	2013
22	22	5.23	1.41	0.27	1940	4.90	1.32	0.27	2050	4.73	1.28	0.27	2086
23	18	4.70	2.59	0.55	1793	4.32	2.38	0.55	1903	4.15	2.28	0.55	1940
23	20	4.94	2.13	0.43	1867	4.61	1.98	0.43	1958	4.44	1.91	0.43	2013
23	22	5.23	1.62	0.31	1940	4.90	1.52	0.31	2050	4.73	1.47	0.31	2086
24	18	4.70	2.78	0.59	1793	4.32	2.55	0.59	1903	4.15	2.45	0.59	1940
24	20	4.94	2.32	0.47	1867	4.61	2.17	0.47	1958	4.44	2.09	0.47	2013
24	22	5.23	1.83	0.35	1940	4.90	1.71	0.35	2050	4.73	1.65	0.35	2086
24	24	5.52	1.27	0.23	2013	5.18	1.19	0.23	2105	5.04	1.16	0.23	2150
25	18	4.70	2.96	0.63	1793	4.32	2.72	0.63	1903	4.15	2.62	0.63	1940
25	20	4.94	2.52	0.51	1867	4.61	2.35	0.51	1958	4.44	2.26	0.51	2013
25	22	5.23	2.04	0.39	1940	4.90	1.91	0.39	2050	4.73	1.84	0.39	2086
25	24	5.52	1.49	0.27	2013	5.18	1.40	0.27	2105	5.04	1.36	0.27	2150
26	18	4.70	3.15	0.67	1793	4.32	2.89	0.67	1903	4.15	2.78	0.67	1940
26	20	4.94	2.72	0.55	1867	4.61	2.53	0.55	1958	4.44	2.44	0.55	2013
26	22	5.23	2.25	0.43	1940	4.90	2.11	0.43	2050	4.73	2.03	0.43	2086
26	24	5.52	1.71	0.31	2013	5.18	1.61	0.31	2105	5.04	1.56	0.31	2150
26	26	5.81	1.10	0.19	2086	5.47	1.04	0.19	2178	5.30	1.01	0.19	2223
27	18	4.70	3.34	0.71	1793	4.32	3.07	0.71	1903	4.15	2.95	0.71	1940
27	20	4.94	2.92	0.59	1867	4.61	2.72	0.59	1958	4.44	2.62	0.59	2013
27	22	5.23	2.46	0.47	1940	4.90	2.30	0.47	2050	4.73	2.22	0.47	2086
27	24	5.52	1.93	0.35	2013	5.18	1.81	0.35	2105	5.04	1.76	0.35	2150
27	26	5.81	1.34	0.23	2086	5.47	1.26	0.23	2178	5.30	1.22	0.23	2223
28	18	4.70	3.53	0.75	1793	4.32	3.24	0.75	1903	4.15	3.11	0.75	1940
28	20	4.94	3.11	0.63	1867	4.61	2.90	0.63	1958	4.44	2.80	0.63	2013
28	22	5.23	2.67	0.51	1940	4.90	2.50	0.51	2050	4.73	2.41	0.51	2086
28	24	5.52	2.15	0.39	2013	5.18	2.02	0.39	2105	5.04	1.97	0.39	2150
28	26	5.81	1.57	0.27	2086	5.47	1.48	0.27	2178	5.30	1.43	0.27	2223
29	18	4.70	3.72	0.79	1793	4.32	3.41	0.79	1903	4.15	3.28	0.79	1940
29	20	4.94	3.31	0.67	1867	4.61	3.09	0.67	1958	4.44	2.97	0.67	2013
29	22	5.23	2.88	0.55	1940	4.90	2.69	0.55	2050	4.73	2.60	0.55	2086
29	24	5.52	2.37	0.43	2013	5.18	2.23	0.43	2105	5.04	2.17	0.43	2150
29	26	5.81	1.80	0.31	2086	5.47	1.70	0.31	2178	5.30	1.64	0.31	2223
30	18	4.70	3.90	0.83	1793	4.32	3.59	0.83	1903	4.15	3.45	0.83	1940
30	20	4.94	3.51	0.71	1867	4.61	3.27	0.71	1958	4.44	3.15	0.71	2013
30	22	5.23	3.09	0.59	1940	4.90	2.89	0.59	2050	4.73	2.79	0.59	2086
30	24	5.52	2.59	0.47	2013	5.18	2.44	0.47	2105	5.04	2.37	0.47	2150
30	26	5.81	2.03	0.35	2086	5.47	1.92	0.35	2178	5.30	1.86	0.35	2223
31	18	4.70	4.09	0.87	1793	4.32	3.76	0.87	1903	4.15	3.61	0.87	1940
31	20	4.94	3.71	0.75	1867	4.61	3.46	0.75	1958	4.44	3.33	0.75	2013
31	22	5.23	3.30	0.63	1940	4.90	3.08	0.63	2050	4.73	2.98	0.63	2086
31	24	5.52	2.82	0.51	2013	5.18	2.64	0.51	2105	5.04	2.57	0.51	2150
31	26	5.81	2.27	0.39	2086	5.47	2.13	0.39	2178	5.30	2.07	0.39	2223
32	18	4.70	4.28	0.91	1793	4.32	3.93	0.91	1903	4.15	3.78	0.91	1940
32	20	4.94	3.91	0.79	1867	4.61	3.64	0.79	1958	4.44	3.51	0.79	2013
32	22	5.23	3.51	0.67	1940	4.90	3.28	0.67	2050	4.73	3.17	0.67	2086
32	24	5.52	3.04	0.55	2013	5.18	2.85	0.55	2105	5.04	2.77	0.55	2150
32	26	5.81	2.50	0.43	2086	5.47	2.35	0.43	2178	5.30	2.28	0.43	2223

NOTE Q : Total capacity (kW) SHF : Sensible heat factor DB : Dry-bulb temperature
 SHC : Sensible heat capacity (kW) INPUT : Total power input (W) WB : Wet-bulb temperature

PERFORMANCE DATA COOL operation Rated frequency 88Hz

MSZ-A24YV -[E1] : MUZ-A24YV -[E1]

CAPACITY:6.0(kW) SHF:0.64 INPUT:1990(W)

		OUTDOOR DB(°C)															
INDOOR DB(°C)	INDOOR WB(°C)	21				25				27				30			
		Q	SHC	SHF	INPUT	Q	SHC	SHF	INPUT	Q	SHC	SHF	INPUT	Q	SHC	SHF	INPUT
21	18	7.05	3.24	0.46	1592	6.75	3.11	0.46	1672	6.48	2.98	0.46	1751	6.24	2.87	0.46	1831
21	20	7.35	2.50	0.34	1672	7.05	2.40	0.34	1771	6.84	2.33	0.34	1811	6.60	2.24	0.34	1891
22	18	7.05	3.53	0.50	1592	6.75	3.38	0.50	1672	6.48	3.24	0.50	1751	6.24	3.12	0.50	1831
22	20	7.35	2.79	0.38	1672	7.05	2.68	0.38	1771	6.84	2.60	0.38	1811	6.60	2.51	0.38	1891
22	22	7.65	1.99	0.26	1731	7.38	1.92	0.26	1841	7.20	1.87	0.26	1891	6.90	1.79	0.26	1970
23	18	7.05	3.81	0.54	1592	6.75	3.65	0.54	1672	6.48	3.50	0.54	1751	6.24	3.37	0.54	1831
23	20	7.35	3.09	0.42	1672	7.05	2.96	0.42	1771	6.84	2.87	0.42	1811	6.60	2.77	0.42	1891
23	22	7.65	2.30	0.30	1731	7.38	2.21	0.30	1841	7.20	2.16	0.30	1891	6.90	2.07	0.30	1970
24	18	7.05	4.09	0.58	1592	6.75	3.92	0.58	1672	6.48	3.76	0.58	1751	6.24	3.62	0.58	1831
24	20	7.35	3.38	0.46	1672	7.05	3.24	0.46	1771	6.84	3.15	0.46	1811	6.60	3.04	0.46	1891
24	22	7.65	2.60	0.34	1731	7.38	2.51	0.34	1841	7.20	2.45	0.34	1891	6.90	2.35	0.34	1970
24	24	8.04	1.77	0.22	1811	7.74	1.70	0.22	1910	7.56	1.66	0.22	1970	7.32	1.61	0.22	2070
25	18	7.05	4.37	0.62	1592	6.75	4.19	0.62	1672	6.48	4.02	0.62	1751	6.24	3.87	0.62	1831
25	20	7.35	3.68	0.50	1672	7.05	3.53	0.50	1771	6.84	3.42	0.50	1811	6.60	3.30	0.50	1891
25	22	7.65	2.91	0.38	1731	7.38	2.80	0.38	1841	7.20	2.74	0.38	1891	6.90	2.62	0.38	1970
25	24	8.04	2.09	0.26	1811	7.74	2.01	0.26	1910	7.56	1.97	0.26	1970	7.32	1.90	0.26	2070
26	18	7.05	4.65	0.66	1592	6.75	4.46	0.66	1672	6.48	4.28	0.66	1751	6.24	4.12	0.66	1831
26	20	7.35	3.97	0.54	1672	7.05	3.81	0.54	1771	6.84	3.69	0.54	1811	6.60	3.56	0.54	1891
26	22	7.65	3.21	0.42	1731	7.38	3.10	0.42	1841	7.20	3.02	0.42	1891	6.90	2.90	0.42	1970
26	24	8.04	2.41	0.30	1811	7.74	2.32	0.30	1910	7.56	2.27	0.30	1970	7.32	2.20	0.30	2070
26	26	8.28	1.49	0.18	1910	8.04	1.45	0.18	2010	7.92	1.43	0.18	2070	7.68	1.38	0.18	2129
27	18	7.05	4.94	0.70	1592	6.75	4.73	0.70	1672	6.48	4.54	0.70	1751	6.24	4.37	0.70	1831
27	20	7.35	4.26	0.58	1672	7.05	4.09	0.58	1771	6.84	3.97	0.58	1811	6.60	3.83	0.58	1891
27	22	7.65	3.52	0.46	1731	7.38	3.39	0.46	1841	7.20	3.31	0.46	1891	6.90	3.17	0.46	1970
27	24	8.04	2.73	0.34	1811	7.74	2.63	0.34	1910	7.56	2.57	0.34	1970	7.32	2.49	0.34	2070
27	26	8.28	1.82	0.22	1910	8.04	1.77	0.22	2010	7.92	1.74	0.22	2070	7.68	1.69	0.22	2129
28	18	7.05	5.22	0.74	1592	6.75	5.00	0.74	1672	6.48	4.80	0.74	1751	6.24	4.62	0.74	1831
28	20	7.35	4.56	0.62	1672	7.05	4.37	0.62	1771	6.84	4.24	0.62	1811	6.60	4.09	0.62	1891
28	22	7.65	3.83	0.50	1731	7.38	3.69	0.50	1841	7.20	3.60	0.50	1891	6.90	3.45	0.50	1970
28	24	8.04	3.06	0.38	1811	7.74	2.94	0.38	1910	7.56	2.87	0.38	1970	7.32	2.78	0.38	2070
28	26	8.28	2.15	0.26	1910	8.04	2.09	0.26	2010	7.92	2.06	0.26	2070	7.68	2.00	0.26	2129
29	18	7.05	5.50	0.78	1592	6.75	5.27	0.78	1672	6.48	5.05	0.78	1751	6.24	4.87	0.78	1831
29	20	7.35	4.85	0.66	1672	7.05	4.65	0.66	1771	6.84	4.51	0.66	1811	6.60	4.36	0.66	1891
29	22	7.65	4.13	0.54	1731	7.38	3.99	0.54	1841	7.20	3.89	0.54	1891	6.90	3.73	0.54	1970
29	24	8.04	3.38	0.42	1811	7.74	3.25	0.42	1910	7.56	3.18	0.42	1970	7.32	3.07	0.42	2070
29	26	8.28	2.48	0.30	1910	8.04	2.41	0.30	2010	7.92	2.38	0.30	2070	7.68	2.30	0.30	2129
30	18	7.05	5.78	0.82	1592	6.75	5.54	0.82	1672	6.48	5.31	0.82	1751	6.24	5.12	0.82	1831
30	20	7.35	5.15	0.70	1672	7.05	4.94	0.70	1771	6.84	4.79	0.70	1811	6.60	4.62	0.70	1891
30	22	7.65	4.44	0.58	1731	7.38	4.28	0.58	1841	7.20	4.18	0.58	1891	6.90	4.00	0.58	1970
30	24	8.04	3.70	0.46	1811	7.74	3.56	0.46	1910	7.56	3.48	0.46	1970	7.32	3.37	0.46	2070
30	26	8.28	2.82	0.34	1910	8.04	2.73	0.34	2010	7.92	2.69	0.34	2070	7.68	2.61	0.34	2129
31	18	7.05	6.06	0.86	1592	6.75	5.81	0.86	1672	6.48	5.57	0.86	1751	6.24	5.37	0.86	1831
31	20	7.35	5.44	0.74	1672	7.05	5.22	0.74	1771	6.84	5.06	0.74	1811	6.60	4.88	0.74	1891
31	22	7.65	4.74	0.62	1731	7.38	4.58	0.62	1841	7.20	4.46	0.62	1891	6.90	4.28	0.62	1970
31	24	8.04	4.02	0.50	1811	7.74	3.87	0.50	1910	7.56	3.78	0.50	1970	7.32	3.66	0.50	2070
31	26	8.28	3.15	0.38	1910	8.04	3.06	0.38	2010	7.92	3.01	0.38	2070	7.68	2.92	0.38	2129
32	18	7.05	6.35	0.90	1592	6.75	6.08	0.90	1672	6.48	5.83	0.90	1751	6.24	5.62	0.90	1831
32	20	7.35	5.73	0.78	1672	7.05	5.50	0.78	1771	6.84	5.34	0.78	1811	6.60	5.15	0.78	1891
32	22	7.65	5.05	0.66	1731	7.38	4.87	0.66	1841	7.20	4.75	0.66	1891	6.90	4.55	0.66	1970
32	24	8.04	4.34	0.54	1811	7.74	4.18	0.54	1910	7.56	4.08	0.54	1970	7.32	3.95	0.54	2070
32	26	8.28	3.48	0.42	1910	8.04	3.38	0.42	2010	7.92	3.33	0.42	2070	7.68	3.23	0.42	2129

NOTE Q : Total capacity (kW) SHF : Sensible heat factor DB : Dry-bulb temperature
 SHC : Sensible heat capacity (kW) INPUT : Total power input (W) WB : Wet-bulb temperature

PERFORMANCE DATA COOL operation Rated frequency 88Hz

MSZ-A24YV -[E1] : MUZ-A24YV -[E1]

CAPACITY : 6.0(kW) SHF : 0.64 INPUT : 1990(W)

		OUTDOOR DB(°C)											
INDOOR DB(°C)	INDOOR WB(°C)	35				40				43			
		Q	SHC	SHF	INPUT	Q	SHC	SHF	INPUT	Q	SHC	SHF	INPUT
21	18	5.88	2.70	0.46	1950	5.40	2.48	0.46	2070	5.19	2.39	0.46	2109
21	20	6.18	2.10	0.34	2030	5.76	1.96	0.34	2129	5.55	1.89	0.34	2189
22	18	5.88	2.94	0.50	1950	5.40	2.70	0.50	2070	5.19	2.60	0.50	2109
22	20	6.18	2.35	0.38	2030	5.76	2.19	0.38	2129	5.55	2.11	0.38	2189
22	22	6.54	1.70	0.26	2109	6.12	1.59	0.26	2229	5.91	1.54	0.26	2269
23	18	5.88	3.18	0.54	1950	5.40	2.92	0.54	2070	5.19	2.80	0.54	2109
23	20	6.18	2.60	0.42	2030	5.76	2.42	0.42	2129	5.55	2.33	0.42	2189
23	22	6.54	1.96	0.30	2109	6.12	1.84	0.30	2229	5.91	1.77	0.30	2269
24	18	5.88	3.41	0.58	1950	5.40	3.13	0.58	2070	5.19	3.01	0.58	2109
24	20	6.18	2.84	0.46	2030	5.76	2.65	0.46	2129	5.55	2.55	0.46	2189
24	22	6.54	2.22	0.34	2109	6.12	2.08	0.34	2229	5.91	2.01	0.34	2269
24	24	6.90	1.52	0.22	2189	6.48	1.43	0.22	2289	6.30	1.39	0.22	2338
25	18	5.88	3.65	0.62	1950	5.40	3.35	0.62	2070	5.19	3.22	0.62	2109
25	20	6.18	3.09	0.50	2030	5.76	2.88	0.50	2129	5.55	2.78	0.50	2189
25	22	6.54	2.49	0.38	2109	6.12	2.33	0.38	2229	5.91	2.25	0.38	2269
25	24	6.90	1.79	0.26	2189	6.48	1.68	0.26	2289	6.30	1.64	0.26	2338
26	18	5.88	3.88	0.66	1950	5.40	3.56	0.66	2070	5.19	3.43	0.66	2109
26	20	6.18	3.34	0.54	2030	5.76	3.11	0.54	2129	5.55	3.00	0.54	2189
26	22	6.54	2.75	0.42	2109	6.12	2.57	0.42	2229	5.91	2.48	0.42	2269
26	24	6.90	2.07	0.30	2189	6.48	1.94	0.30	2289	6.30	1.89	0.30	2338
26	26	7.26	1.31	0.18	2269	6.84	1.23	0.18	2368	6.63	1.19	0.18	2418
27	18	5.88	4.12	0.70	1950	5.40	3.78	0.70	2070	5.19	3.63	0.70	2109
27	20	6.18	3.58	0.58	2030	5.76	3.34	0.58	2129	5.55	3.22	0.58	2189
27	22	6.54	3.01	0.46	2109	6.12	2.82	0.46	2229	5.91	2.72	0.46	2269
27	24	6.90	2.35	0.34	2189	6.48	2.20	0.34	2289	6.30	2.14	0.34	2338
27	26	7.26	1.60	0.22	2269	6.84	1.50	0.22	2368	6.63	1.46	0.22	2418
28	18	5.88	4.35	0.74	1950	5.40	4.00	0.74	2070	5.19	3.84	0.74	2109
28	20	6.18	3.83	0.62	2030	5.76	3.57	0.62	2129	5.55	3.44	0.62	2189
28	22	6.54	3.27	0.50	2109	6.12	3.06	0.50	2229	5.91	2.96	0.50	2269
28	24	6.90	2.62	0.38	2189	6.48	2.46	0.38	2289	6.30	2.39	0.38	2338
28	26	7.26	1.89	0.26	2269	6.84	1.78	0.26	2368	6.63	1.72	0.26	2418
29	18	5.88	4.59	0.78	1950	5.40	4.21	0.78	2070	5.19	4.05	0.78	2109
29	20	6.18	4.08	0.66	2030	5.76	3.80	0.66	2129	5.55	3.66	0.66	2189
29	22	6.54	3.53	0.54	2109	6.12	3.30	0.54	2229	5.91	3.19	0.54	2269
29	24	6.90	2.90	0.42	2189	6.48	2.72	0.42	2289	6.30	2.65	0.42	2338
29	26	7.26	2.18	0.30	2269	6.84	2.05	0.30	2368	6.63	1.99	0.30	2418
30	18	5.88	4.82	0.82	1950	5.40	4.43	0.82	2070	5.19	4.26	0.82	2109
30	20	6.18	4.33	0.70	2030	5.76	4.03	0.70	2129	5.55	3.89	0.70	2189
30	22	6.54	3.79	0.58	2109	6.12	3.55	0.58	2229	5.91	3.43	0.58	2269
30	24	6.90	3.17	0.46	2189	6.48	2.98	0.46	2289	6.30	2.90	0.46	2338
30	26	7.26	2.47	0.34	2269	6.84	2.33	0.34	2368	6.63	2.25	0.34	2418
31	18	5.88	5.06	0.86	1950	5.40	4.64	0.86	2070	5.19	4.46	0.86	2109
31	20	6.18	4.57	0.74	2030	5.76	4.26	0.74	2129	5.55	4.11	0.74	2189
31	22	6.54	4.05	0.62	2109	6.12	3.79	0.62	2229	5.91	3.66	0.62	2269
31	24	6.90	3.45	0.50	2189	6.48	3.24	0.50	2289	6.30	3.15	0.50	2338
31	26	7.26	2.76	0.38	2269	6.84	2.60	0.38	2368	6.63	2.52	0.38	2418
32	18	5.88	5.29	0.90	1950	5.40	4.86	0.90	2070	5.19	4.67	0.90	2109
32	20	6.18	4.82	0.78	2030	5.76	4.49	0.78	2129	5.55	4.33	0.78	2189
32	22	6.54	4.32	0.66	2109	6.12	4.04	0.66	2229	5.91	3.90	0.66	2269
32	24	6.90	3.73	0.54	2189	6.48	3.50	0.54	2289	6.30	3.40	0.54	2338
32	26	7.26	3.05	0.42	2269	6.84	2.87	0.42	2368	6.63	2.78	0.42	2418

NOTE Q : Total capacity (kW) SHF : Sensible heat factor DB : Dry-bulb temperature
 SHC : Sensible heat capacity (kW) INPUT : Total power input (W) WB : Wet-bulb temperature

PERFORMANCE DATA COOL operation Rated frequency 102Hz

MCFZ-A24WV -[E1] : MUZ-A24YV -[E1]

CAPACITY:5.5(kW) SHF:0.65 INPUT:2420(W)

		OUTDOOR DB(°C)															
INDOOR DB(°C)	INDOOR WB(°C)	21				25				27				30			
		Q	SHC	SHF	INPUT	Q	SHC	SHF	INPUT	Q	SHC	SHF	INPUT	Q	SHC	SHF	INPUT
21	18	6.46	3.04	0.47	1936	6.19	2.91	0.47	2033	5.94	2.79	0.47	2130	5.72	2.69	0.47	2226
21	20	6.74	2.36	0.35	2033	6.46	2.26	0.35	2154	6.27	2.19	0.35	2202	6.05	2.12	0.35	2299
22	18	6.46	3.30	0.51	1936	6.19	3.16	0.51	2033	5.94	3.03	0.51	2130	5.72	2.92	0.51	2226
22	20	6.74	2.63	0.39	2033	6.46	2.52	0.39	2154	6.27	2.45	0.39	2202	6.05	2.36	0.39	2299
22	22	7.01	1.89	0.27	2105	6.77	1.83	0.27	2239	6.60	1.78	0.27	2299	6.33	1.71	0.27	2396
23	18	6.46	3.55	0.55	1936	6.19	3.40	0.55	2033	5.94	3.27	0.55	2130	5.72	3.15	0.55	2226
23	20	6.74	2.90	0.43	2033	6.46	2.78	0.43	2154	6.27	2.70	0.43	2202	6.05	2.60	0.43	2299
23	22	7.01	2.17	0.31	2105	6.77	2.10	0.31	2239	6.60	2.05	0.31	2299	6.33	1.96	0.31	2396
24	18	6.46	3.81	0.59	1936	6.19	3.65	0.59	2033	5.94	3.50	0.59	2130	5.72	3.37	0.59	2226
24	20	6.74	3.17	0.47	2033	6.46	3.04	0.47	2154	6.27	2.95	0.47	2202	6.05	2.84	0.47	2299
24	22	7.01	2.45	0.35	2105	6.77	2.37	0.35	2239	6.60	2.31	0.35	2299	6.33	2.21	0.35	2396
24	24	7.37	1.70	0.23	2202	7.10	1.63	0.23	2323	6.93	1.59	0.23	2396	6.71	1.54	0.23	2517
25	18	6.46	4.07	0.63	1936	6.19	3.90	0.63	2033	5.94	3.74	0.63	2130	5.72	3.60	0.63	2226
25	20	6.74	3.44	0.51	2033	6.46	3.30	0.51	2154	6.27	3.20	0.51	2202	6.05	3.09	0.51	2299
25	22	7.01	2.73	0.39	2105	6.77	2.64	0.39	2239	6.60	2.57	0.39	2299	6.33	2.47	0.39	2396
25	24	7.37	1.99	0.27	2202	7.10	1.92	0.27	2323	6.93	1.87	0.27	2396	6.71	1.81	0.27	2517
26	18	6.46	4.33	0.67	1936	6.19	4.15	0.67	2033	5.94	3.98	0.67	2130	5.72	3.83	0.67	2226
26	20	6.74	3.71	0.55	2033	6.46	3.55	0.55	2154	6.27	3.45	0.55	2202	6.05	3.33	0.55	2299
26	22	7.01	3.02	0.43	2105	6.77	2.91	0.43	2239	6.60	2.84	0.43	2299	6.33	2.72	0.43	2396
26	24	7.37	2.28	0.31	2202	7.10	2.20	0.31	2323	6.93	2.15	0.31	2396	6.71	2.08	0.31	2517
26	26	7.59	1.44	0.19	2323	7.37	1.40	0.19	2444	7.26	1.38	0.19	2517	7.04	1.34	0.19	2589
27	18	6.46	4.59	0.71	1936	6.19	4.39	0.71	2033	5.94	4.22	0.71	2130	5.72	4.06	0.71	2226
27	20	6.74	3.98	0.59	2033	6.46	3.81	0.59	2154	6.27	3.70	0.59	2202	6.05	3.57	0.59	2299
27	22	7.01	3.30	0.47	2105	6.77	3.18	0.47	2239	6.60	3.10	0.47	2299	6.33	2.97	0.47	2396
27	24	7.37	2.58	0.35	2202	7.10	2.48	0.35	2323	6.93	2.43	0.35	2396	6.71	2.35	0.35	2517
27	26	7.59	1.75	0.23	2323	7.37	1.70	0.23	2444	7.26	1.67	0.23	2517	7.04	1.62	0.23	2589
28	18	6.46	4.85	0.75	1936	6.19	4.64	0.75	2033	5.94	4.46	0.75	2130	5.72	4.29	0.75	2226
28	20	6.74	4.24	0.63	2033	6.46	4.07	0.63	2154	6.27	3.95	0.63	2202	6.05	3.81	0.63	2299
28	22	7.01	3.58	0.51	2105	6.77	3.45	0.51	2239	6.60	3.37	0.51	2299	6.33	3.23	0.51	2396
28	24	7.37	2.87	0.39	2202	7.10	2.77	0.39	2323	6.93	2.70	0.39	2396	6.71	2.62	0.39	2517
28	26	7.59	2.05	0.27	2323	7.37	1.99	0.27	2444	7.26	1.96	0.27	2517	7.04	1.90	0.27	2589
29	18	6.46	5.11	0.79	1936	6.19	4.89	0.79	2033	5.94	4.69	0.79	2130	5.72	4.52	0.79	2226
29	20	6.74	4.51	0.67	2033	6.46	4.33	0.67	2154	6.27	4.20	0.67	2202	6.05	4.05	0.67	2299
29	22	7.01	3.86	0.55	2105	6.77	3.72	0.55	2239	6.60	3.63	0.55	2299	6.33	3.48	0.55	2396
29	24	7.37	3.17	0.43	2202	7.10	3.05	0.43	2323	6.93	2.98	0.43	2396	6.71	2.89	0.43	2517
29	26	7.59	2.35	0.31	2323	7.37	2.28	0.31	2444	7.26	2.25	0.31	2517	7.04	2.18	0.31	2589
30	18	6.46	5.36	0.83	1936	6.19	5.14	0.83	2033	5.94	4.93	0.83	2130	5.72	4.75	0.83	2226
30	20	6.74	4.78	0.71	2033	6.46	4.59	0.71	2154	6.27	4.45	0.71	2202	6.05	4.30	0.71	2299
30	22	7.01	4.14	0.59	2105	6.77	3.99	0.59	2239	6.60	3.89	0.59	2299	6.33	3.73	0.59	2396
30	24	7.37	3.46	0.47	2202	7.10	3.33	0.47	2323	6.93	3.26	0.47	2396	6.71	3.15	0.47	2517
30	26	7.59	2.66	0.35	2323	7.37	2.58	0.35	2444	7.26	2.54	0.35	2517	7.04	2.46	0.35	2589
31	18	6.46	5.62	0.87	1936	6.19	5.38	0.87	2033	5.94	5.17	0.87	2130	5.72	4.98	0.87	2226
31	20	6.74	5.05	0.75	2033	6.46	4.85	0.75	2154	6.27	4.70	0.75	2202	6.05	4.54	0.75	2299
31	22	7.01	4.42	0.63	2105	6.77	4.26	0.63	2239	6.60	4.16	0.63	2299	6.33	3.98	0.63	2396
31	24	7.37	3.76	0.51	2202	7.10	3.62	0.51	2323	6.93	3.53	0.51	2396	6.71	3.42	0.51	2517
31	26	7.59	2.96	0.39	2323	7.37	2.87	0.39	2444	7.26	2.83	0.39	2517	7.04	2.75	0.39	2589
32	18	6.46	5.88	0.91	1936	6.19	5.63	0.91	2033	5.94	5.41	0.91	2130	5.72	5.21	0.91	2226
32	20	6.74	5.32	0.79	2033	6.46	5.11	0.79	2154	6.27	4.95	0.79	2202	6.05	4.78	0.79	2299
32	22	7.01	4.70	0.67	2105	6.77	4.53	0.67	2239	6.60	4.42	0.67	2299	6.33	4.24	0.67	2396
32	24	7.37	4.05	0.55	2202	7.10	3.90	0.55	2323	6.93	3.81	0.55	2396	6.71	3.69	0.55	2517
32	26	7.59	3.26	0.43	2323	7.37	3.17	0.43	2444	7.26	3.12	0.43	2517	7.04	3.03	0.43	2589

NOTE Q : Total capacity (kW) SHF : Sensible heat factor DB : Dry-bulb temperature
 SHC : Sensible heat capacity (kW) INPUT : Total power input (W) WB : Wet-bulb temperature

PERFORMANCE DATA COOL operation Rated frequency 102Hz

MCFZ-A24WV -[E1] : MUZ-A24YV -[E1]

CAPACITY : 5.5(kW) SHF : 0.65 INPUT : 2420(W)

		OUTDOOR DB(°C)											
INDOOR DB(°C)	INDOOR WB(°C)	35				40				43			
		Q	SHC	SHF	INPUT	Q	SHC	SHF	INPUT	Q	SHC	SHF	INPUT
21	18	5.39	2.53	0.47	2372	4.95	2.33	0.47	2517	4.76	2.24	0.47	2565
21	20	5.67	1.98	0.35	2468	5.28	1.85	0.35	2589	5.09	1.78	0.35	2662
22	18	5.39	2.75	0.51	2372	4.95	2.52	0.51	2517	4.76	2.43	0.51	2565
22	20	5.67	2.21	0.39	2468	5.28	2.06	0.39	2589	5.09	1.98	0.39	2662
22	22	6.00	1.62	0.27	2565	5.61	1.51	0.27	2710	5.42	1.46	0.27	2759
23	18	5.39	2.96	0.55	2372	4.95	2.72	0.55	2517	4.76	2.62	0.55	2565
23	20	5.67	2.44	0.43	2468	5.28	2.27	0.43	2589	5.09	2.19	0.43	2662
23	22	6.00	1.86	0.31	2565	5.61	1.74	0.31	2710	5.42	1.68	0.31	2759
24	18	5.39	3.18	0.59	2372	4.95	2.92	0.59	2517	4.76	2.81	0.59	2565
24	20	5.67	2.66	0.47	2468	5.28	2.48	0.47	2589	5.09	2.39	0.47	2662
24	22	6.00	2.10	0.35	2565	5.61	1.96	0.35	2710	5.42	1.90	0.35	2759
24	24	6.33	1.45	0.23	2662	5.94	1.37	0.23	2783	5.78	1.33	0.23	2844
25	18	5.39	3.40	0.63	2372	4.95	3.12	0.63	2517	4.76	3.00	0.63	2565
25	20	5.67	2.89	0.51	2468	5.28	2.69	0.51	2589	5.09	2.59	0.51	2662
25	22	6.00	2.34	0.39	2565	5.61	2.19	0.39	2710	5.42	2.11	0.39	2759
25	24	6.33	1.71	0.27	2662	5.94	1.60	0.27	2783	5.78	1.56	0.27	2844
26	18	5.39	3.61	0.67	2372	4.95	3.32	0.67	2517	4.76	3.19	0.67	2565
26	20	5.67	3.12	0.55	2468	5.28	2.90	0.55	2589	5.09	2.80	0.55	2662
26	22	6.00	2.58	0.43	2565	5.61	2.41	0.43	2710	5.42	2.33	0.43	2759
26	24	6.33	1.96	0.31	2662	5.94	1.84	0.31	2783	5.78	1.79	0.31	2844
26	26	6.66	1.26	0.19	2759	6.27	1.19	0.19	2880	6.08	1.15	0.19	2940
27	18	5.39	3.83	0.71	2372	4.95	3.51	0.71	2517	4.76	3.38	0.71	2565
27	20	5.67	3.34	0.59	2468	5.28	3.12	0.59	2589	5.09	3.00	0.59	2662
27	22	6.00	2.82	0.47	2565	5.61	2.64	0.47	2710	5.42	2.55	0.47	2759
27	24	6.33	2.21	0.35	2662	5.94	2.08	0.35	2783	5.78	2.02	0.35	2844
27	26	6.66	1.53	0.23	2759	6.27	1.44	0.23	2880	6.08	1.40	0.23	2940
28	18	5.39	4.04	0.75	2372	4.95	3.71	0.75	2517	4.76	3.57	0.75	2565
28	20	5.67	3.57	0.63	2468	5.28	3.33	0.63	2589	5.09	3.21	0.63	2662
28	22	6.00	3.06	0.51	2565	5.61	2.86	0.51	2710	5.42	2.76	0.51	2759
28	24	6.33	2.47	0.39	2662	5.94	2.32	0.39	2783	5.78	2.25	0.39	2844
28	26	6.66	1.80	0.27	2759	6.27	1.69	0.27	2880	6.08	1.64	0.27	2940
29	18	5.39	4.26	0.79	2372	4.95	3.91	0.79	2517	4.76	3.76	0.79	2565
29	20	5.67	3.80	0.67	2468	5.28	3.54	0.67	2589	5.09	3.41	0.67	2662
29	22	6.00	3.30	0.55	2565	5.61	3.09	0.55	2710	5.42	2.98	0.55	2759
29	24	6.33	2.72	0.43	2662	5.94	2.55	0.43	2783	5.78	2.48	0.43	2844
29	26	6.66	2.06	0.31	2759	6.27	1.94	0.31	2880	6.08	1.88	0.31	2940
30	18	5.39	4.47	0.83	2372	4.95	4.11	0.83	2517	4.76	3.95	0.83	2565
30	20	5.67	4.02	0.71	2468	5.28	3.75	0.71	2589	5.09	3.61	0.71	2662
30	22	6.00	3.54	0.59	2565	5.61	3.31	0.59	2710	5.42	3.20	0.59	2759
30	24	6.33	2.97	0.47	2662	5.94	2.79	0.47	2783	5.78	2.71	0.47	2844
30	26	6.66	2.33	0.35	2759	6.27	2.19	0.35	2880	6.08	2.13	0.35	2940
31	18	5.39	4.69	0.87	2372	4.95	4.31	0.87	2517	4.76	4.14	0.87	2565
31	20	5.67	4.25	0.75	2468	5.28	3.96	0.75	2589	5.09	3.82	0.75	2662
31	22	6.00	3.78	0.63	2565	5.61	3.53	0.63	2710	5.42	3.41	0.63	2759
31	24	6.33	3.23	0.51	2662	5.94	3.03	0.51	2783	5.78	2.95	0.51	2844
31	26	6.66	2.60	0.39	2759	6.27	2.45	0.39	2880	6.08	2.37	0.39	2940
32	18	5.39	4.90	0.91	2372	4.95	4.50	0.91	2517	4.76	4.33	0.91	2565
32	20	5.67	4.48	0.79	2468	5.28	4.17	0.79	2589	5.09	4.02	0.79	2662
32	22	6.00	4.02	0.67	2565	5.61	3.76	0.67	2710	5.42	3.63	0.67	2759
32	24	6.33	3.48	0.55	2662	5.94	3.27	0.55	2783	5.78	3.18	0.55	2844
32	26	6.66	2.86	0.43	2759	6.27	2.70	0.43	2880	6.08	2.61	0.43	2940

NOTE Q : Total capacity (kW) SHF : Sensible heat factor DB : Dry-bulb temperature
 SHC : Sensible heat capacity (kW) INPUT : Total power input (W) WB : Wet-bulb temperature

PERFORMANCE DATA COOL operation Rated frequency 63Hz

MSZ-A26YV -[E1] : MUZ-A26YV -[E1]

CAPACITY:7.1(kW) SHF:0.63 INPUT:2500(W)

		OUTDOOR DB(°C)															
INDOOR DB(°C)	INDOOR WB(°C)	21				25				27				30			
		Q	SHC	SHF	INPUT	Q	SHC	SHF	INPUT	Q	SHC	SHF	INPUT	Q	SHC	SHF	INPUT
21	18	8.34	3.75	0.45	2000	7.99	3.59	0.45	2100	7.67	3.45	0.45	2200	7.38	3.32	0.45	2300
21	20	8.70	2.87	0.33	2100	8.34	2.75	0.33	2225	8.09	2.67	0.33	2275	7.81	2.58	0.33	2375
22	18	8.34	4.09	0.49	2000	7.99	3.91	0.49	2100	7.67	3.76	0.49	2200	7.38	3.62	0.49	2300
22	20	8.70	3.22	0.37	2100	8.34	3.09	0.37	2225	8.09	2.99	0.37	2275	7.81	2.89	0.37	2375
22	22	9.05	2.26	0.25	2175	8.73	2.18	0.25	2313	8.52	2.13	0.25	2375	8.17	2.04	0.25	2475
23	18	8.34	4.42	0.53	2000	7.99	4.23	0.53	2100	7.67	4.06	0.53	2200	7.38	3.91	0.53	2300
23	20	8.70	3.57	0.41	2100	8.34	3.42	0.41	2225	8.09	3.32	0.41	2275	7.81	3.20	0.41	2375
23	22	9.05	2.63	0.29	2175	8.73	2.53	0.29	2313	8.52	2.47	0.29	2375	8.17	2.37	0.29	2475
24	18	8.34	4.76	0.57	2000	7.99	4.55	0.57	2100	7.67	4.37	0.57	2200	7.38	4.21	0.57	2300
24	20	8.70	3.91	0.45	2100	8.34	3.75	0.45	2225	8.09	3.64	0.45	2275	7.81	3.51	0.45	2375
24	22	9.05	2.99	0.33	2175	8.73	2.88	0.33	2313	8.52	2.81	0.33	2375	8.17	2.69	0.33	2475
24	24	9.51	2.00	0.21	2275	9.16	1.92	0.21	2400	8.95	1.88	0.21	2475	8.66	1.82	0.21	2600
25	18	8.34	5.09	0.61	2000	7.99	4.87	0.61	2100	7.67	4.68	0.61	2200	7.38	4.50	0.61	2300
25	20	8.70	4.26	0.49	2100	8.34	4.09	0.49	2225	8.09	3.97	0.49	2275	7.81	3.83	0.49	2375
25	22	9.05	3.35	0.37	2175	8.73	3.23	0.37	2313	8.52	3.15	0.37	2375	8.17	3.02	0.37	2475
25	24	9.51	2.38	0.25	2275	9.16	2.29	0.25	2400	8.95	2.24	0.25	2475	8.66	2.17	0.25	2600
26	18	8.34	5.42	0.65	2000	7.99	5.19	0.65	2100	7.67	4.98	0.65	2200	7.38	4.80	0.65	2300
26	20	8.70	4.61	0.53	2100	8.34	4.42	0.53	2225	8.09	4.29	0.53	2275	7.81	4.14	0.53	2375
26	22	9.05	3.71	0.41	2175	8.73	3.58	0.41	2313	8.52	3.49	0.41	2375	8.17	3.35	0.41	2475
26	24	9.51	2.76	0.29	2275	9.16	2.66	0.29	2400	8.95	2.59	0.29	2475	8.66	2.51	0.29	2600
26	26	9.80	1.67	0.17	2400	9.51	1.62	0.17	2525	9.37	1.59	0.17	2600	9.09	1.54	0.17	2675
27	18	8.34	5.76	0.69	2000	7.99	5.51	0.69	2100	7.67	5.29	0.69	2200	7.38	5.09	0.69	2300
27	20	8.70	4.96	0.57	2100	8.34	4.76	0.57	2225	8.09	4.61	0.57	2275	7.81	4.45	0.57	2375
27	22	9.05	4.07	0.45	2175	8.73	3.93	0.45	2313	8.52	3.83	0.45	2375	8.17	3.67	0.45	2475
27	24	9.51	3.14	0.33	2275	9.16	3.02	0.33	2400	8.95	2.95	0.33	2475	8.66	2.86	0.33	2600
27	26	9.80	2.06	0.21	2400	9.51	2.00	0.21	2525	9.37	1.97	0.21	2600	9.09	1.91	0.21	2675
28	18	8.34	6.09	0.73	2000	7.99	5.83	0.73	2100	7.67	5.60	0.73	2200	7.38	5.39	0.73	2300
28	20	8.70	5.31	0.61	2100	8.34	5.09	0.61	2225	8.09	4.94	0.61	2275	7.81	4.76	0.61	2375
28	22	9.05	4.44	0.49	2175	8.73	4.28	0.49	2313	8.52	4.17	0.49	2375	8.17	4.00	0.49	2475
28	24	9.51	3.52	0.37	2275	9.16	3.39	0.37	2400	8.95	3.31	0.37	2475	8.66	3.20	0.37	2600
28	26	9.80	2.45	0.25	2400	9.51	2.38	0.25	2525	9.37	2.34	0.25	2600	9.09	2.27	0.25	2675
29	18	8.34	6.42	0.77	2000	7.99	6.15	0.77	2100	7.67	5.90	0.77	2200	7.38	5.69	0.77	2300
29	20	8.70	5.65	0.65	2100	8.34	5.42	0.65	2225	8.09	5.26	0.65	2275	7.81	5.08	0.65	2375
29	22	9.05	4.80	0.53	2175	8.73	4.63	0.53	2313	8.52	4.52	0.53	2375	8.17	4.33	0.53	2475
29	24	9.51	3.90	0.41	2275	9.16	3.76	0.41	2400	8.95	3.67	0.41	2475	8.66	3.55	0.41	2600
29	26	9.80	2.84	0.29	2400	9.51	2.76	0.29	2525	9.37	2.72	0.29	2600	9.09	2.64	0.29	2675
30	18	8.34	6.76	0.81	2000	7.99	6.47	0.81	2100	7.67	6.21	0.81	2200	7.38	5.98	0.81	2300
30	20	8.70	6.00	0.69	2100	8.34	5.76	0.69	2225	8.09	5.58	0.69	2275	7.81	5.39	0.69	2375
30	22	9.05	5.16	0.57	2175	8.73	4.98	0.57	2313	8.52	4.86	0.57	2375	8.17	4.65	0.57	2475
30	24	9.51	4.28	0.45	2275	9.16	4.12	0.45	2400	8.95	4.03	0.45	2475	8.66	3.90	0.45	2600
30	26	9.80	3.23	0.33	2400	9.51	3.14	0.33	2525	9.37	3.09	0.33	2600	9.09	3.00	0.33	2675
31	18	8.34	7.09	0.85	2000	7.99	6.79	0.85	2100	7.67	6.52	0.85	2200	7.38	6.28	0.85	2300
31	20	8.70	6.35	0.73	2100	8.34	6.09	0.73	2225	8.09	5.91	0.73	2275	7.81	5.70	0.73	2375
31	22	9.05	5.52	0.61	2175	8.73	5.33	0.61	2313	8.52	5.20	0.61	2375	8.17	4.98	0.61	2475
31	24	9.51	4.66	0.49	2275	9.16	4.49	0.49	2400	8.95	4.38	0.49	2475	8.66	4.24	0.49	2600
31	26	9.80	3.63	0.37	2400	9.51	3.52	0.37	2525	9.37	3.47	0.37	2600	9.09	3.36	0.37	2675
32	18	8.34	7.42	0.89	2000	7.99	7.11	0.89	2100	7.67	6.82	0.89	2200	7.38	6.57	0.89	2300
32	20	8.70	6.70	0.77	2100	8.34	6.42	0.77	2225	8.09	6.23	0.77	2275	7.81	6.01	0.77	2375
32	22	9.05	5.88	0.65	2175	8.73	5.68	0.65	2313	8.52	5.54	0.65	2375	8.17	5.31	0.65	2475
32	24	9.51	5.04	0.53	2275	9.16	4.85	0.53	2400	8.95	4.74	0.53	2475	8.66	4.59	0.53	2600
32	26	9.80	4.02	0.41	2400	9.51	3.90	0.41	2525	9.37	3.84	0.41	2600	9.09	3.73	0.41	2675

NOTE Q : Total capacity (kW) SHF : Sensible heat factor DB : Dry-bulb temperature
 SHC : Sensible heat capacity (kW) INPUT : Total power input (W) WB : Wet-bulb temperature

PERFORMANCE DATA COOL operation Rated frequency 63Hz

MSZ-A26YV -[E1] : MUZ-A26YV -[E1]

CAPACITY : 7.1(kW) SHF : 0.63 INPUT : 2500(W)

INDOOR		OUTDOOR DB(°C)											
DB(°C)	WB(°C)	35				40				43			
		Q	SHC	SHF	INPUT	Q	SHC	SHF	INPUT	Q	SHC	SHF	INPUT
21	18	6.96	3.13	0.45	2450	6.39	2.88	0.45	2600	6.14	2.76	0.45	2650
21	20	7.31	2.41	0.33	2550	6.82	2.25	0.33	2675	6.57	2.17	0.33	2750
22	18	6.96	3.41	0.49	2450	6.39	3.13	0.49	2600	6.14	3.01	0.49	2650
22	20	7.31	2.71	0.37	2550	6.82	2.52	0.37	2675	6.57	2.43	0.37	2750
22	22	7.74	1.93	0.25	2650	7.24	1.81	0.25	2800	6.99	1.75	0.25	2850
23	18	6.96	3.69	0.53	2450	6.39	3.39	0.53	2600	6.14	3.25	0.53	2650
23	20	7.31	3.00	0.41	2550	6.82	2.79	0.41	2675	6.57	2.69	0.41	2750
23	22	7.74	2.24	0.29	2650	7.24	2.10	0.29	2800	6.99	2.03	0.29	2850
24	18	6.96	3.97	0.57	2450	6.39	3.64	0.57	2600	6.14	3.50	0.57	2650
24	20	7.31	3.29	0.45	2550	6.82	3.07	0.45	2675	6.57	2.96	0.45	2750
24	22	7.74	2.55	0.33	2650	7.24	2.39	0.33	2800	6.99	2.31	0.33	2850
24	24	8.17	1.71	0.21	2750	7.67	1.61	0.21	2875	7.46	1.57	0.21	2938
25	18	6.96	4.24	0.61	2450	6.39	3.90	0.61	2600	6.14	3.75	0.61	2650
25	20	7.31	3.58	0.49	2550	6.82	3.34	0.49	2675	6.57	3.22	0.49	2750
25	22	7.74	2.86	0.37	2650	7.24	2.68	0.37	2800	6.99	2.59	0.37	2850
25	24	8.17	2.04	0.25	2750	7.67	1.92	0.25	2875	7.46	1.86	0.25	2938
26	18	6.96	4.52	0.65	2450	6.39	4.15	0.65	2600	6.14	3.99	0.65	2650
26	20	7.31	3.88	0.53	2550	6.82	3.61	0.53	2675	6.57	3.48	0.53	2750
26	22	7.74	3.17	0.41	2650	7.24	2.97	0.41	2800	6.99	2.87	0.41	2850
26	24	8.17	2.37	0.29	2750	7.67	2.22	0.29	2875	7.46	2.16	0.29	2938
26	26	8.59	1.46	0.17	2850	8.09	1.38	0.17	2975	7.85	1.33	0.17	3038
27	18	6.96	4.80	0.69	2450	6.39	4.41	0.69	2600	6.14	4.24	0.69	2650
27	20	7.31	4.17	0.57	2550	6.82	3.89	0.57	2675	6.57	3.74	0.57	2750
27	22	7.74	3.48	0.45	2650	7.24	3.26	0.45	2800	6.99	3.15	0.45	2850
27	24	8.17	2.69	0.33	2750	7.67	2.53	0.33	2875	7.46	2.46	0.33	2938
27	26	8.59	1.80	0.21	2850	8.09	1.70	0.21	2975	7.85	1.65	0.21	3038
28	18	6.96	5.08	0.73	2450	6.39	4.66	0.73	2600	6.14	4.48	0.73	2650
28	20	7.31	4.46	0.61	2550	6.82	4.16	0.61	2675	6.57	4.01	0.61	2750
28	22	7.74	3.79	0.49	2650	7.24	3.55	0.49	2800	6.99	3.43	0.49	2850
28	24	8.17	3.02	0.37	2750	7.67	2.84	0.37	2875	7.46	2.76	0.37	2938
28	26	8.59	2.15	0.25	2850	8.09	2.02	0.25	2975	7.85	1.96	0.25	3038
29	18	6.96	5.36	0.77	2450	6.39	4.92	0.77	2600	6.14	4.73	0.77	2650
29	20	7.31	4.75	0.65	2550	6.82	4.43	0.65	2675	6.57	4.27	0.65	2750
29	22	7.74	4.10	0.53	2650	7.24	3.84	0.53	2800	6.99	3.71	0.53	2850
29	24	8.17	3.35	0.41	2750	7.67	3.14	0.41	2875	7.46	3.06	0.41	2938
29	26	8.59	2.49	0.29	2850	8.09	2.35	0.29	2975	7.85	2.28	0.29	3038
30	18	6.96	5.64	0.81	2450	6.39	5.18	0.81	2600	6.14	4.97	0.81	2650
30	20	7.31	5.05	0.69	2550	6.82	4.70	0.69	2675	6.57	4.53	0.69	2750
30	22	7.74	4.41	0.57	2650	7.24	4.13	0.57	2800	6.99	3.99	0.57	2850
30	24	8.17	3.67	0.45	2750	7.67	3.45	0.45	2875	7.46	3.35	0.45	2938
30	26	8.59	2.84	0.33	2850	8.09	2.67	0.33	2975	7.85	2.59	0.33	3038
31	18	6.96	5.91	0.85	2450	6.39	5.43	0.85	2600	6.14	5.22	0.85	2650
31	20	7.31	5.34	0.73	2550	6.82	4.98	0.73	2675	6.57	4.79	0.73	2750
31	22	7.74	4.72	0.61	2650	7.24	4.42	0.61	2800	6.99	4.27	0.61	2850
31	24	8.17	4.00	0.49	2750	7.67	3.76	0.49	2875	7.46	3.65	0.49	2938
31	26	8.59	3.18	0.37	2850	8.09	2.99	0.37	2975	7.85	2.90	0.37	3038
32	18	6.96	6.19	0.89	2450	6.39	5.69	0.89	2600	6.14	5.47	0.89	2650
32	20	7.31	5.63	0.77	2550	6.82	5.25	0.77	2675	6.57	5.06	0.77	2750
32	22	7.74	5.03	0.65	2650	7.24	4.71	0.65	2800	6.99	4.55	0.65	2850
32	24	8.17	4.33	0.53	2750	7.67	4.06	0.53	2875	7.46	3.95	0.53	2938
32	26	8.59	3.52	0.41	2850	8.09	3.32	0.41	2975	7.85	3.22	0.41	3038

NOTE Q : Total capacity (kW) SHF : Sensible heat factor DB : Dry-bulb temperature
 SHC : Sensible heat capacity (kW) INPUT : Total power input (W) WB : Wet-bulb temperature

PERFORMANCE DATA HEAT operation

MSZ-A18YV -[E1] : MUZ-A18YV -[E1] Rated frequency 82Hz

CAPACITY:5.9(kW) INPUT:1730(W)

INDOOR DB(°C)	OUTDOOR WB(°C)													
	-10		-5		0		5		10		15		20	
	Q	INPUT	Q	INPUT	Q	INPUT	Q	INPUT	Q	INPUT	Q	INPUT	Q	INPUT
15	3.72	1125	4.48	1349	5.25	1522	6.02	1644	6.79	1747	7.49	1799	8.26	1834
21	3.54	1211	4.25	1436	5.02	1592	5.72	1713	6.49	1799	7.20	1851	7.94	1920
26	3.19	1298	3.95	1522	4.66	1678	5.43	1799	6.20	1886	6.90	1938	7.67	1990

MCFZ-A18WV -[E1] : MUZ-A18YV -[E1] Rated frequency 86Hz

CAPACITY:6.0(kW) INPUT:2080(W)

INDOOR DB(°C)	OUTDOOR WB(°C)													
	-10		-5		0		5		10		15		20	
	Q	INPUT	Q	INPUT	Q	INPUT	Q	INPUT	Q	INPUT	Q	INPUT	Q	INPUT
15	3.78	1352	4.56	1622	5.34	1830	6.12	1976	6.90	2101	7.62	2163	8.40	2205
21	3.60	1456	4.32	1726	5.10	1914	5.82	2059	6.60	2163	7.32	2226	8.07	2309
26	3.24	1560	4.02	1830	4.74	2018	5.52	2163	6.30	2267	7.02	2330	7.80	2392

MSZ-A24YV -[E1] : MUZ-A24YV -[E1] Rated frequency 96Hz

CAPACITY:6.8(kW) INPUT:2050(W)

INDOOR DB(°C)	OUTDOOR WB(°C)													
	-10		-5		0		5		10		15		20	
	Q	INPUT	Q	INPUT	Q	INPUT	Q	INPUT	Q	INPUT	Q	INPUT	Q	INPUT
15	4.28	1333	5.17	1599	6.05	1804	6.94	1948	7.82	2071	8.64	2132	9.52	2173
21	4.08	1435	4.90	1702	5.78	1886	6.60	2030	7.48	2132	8.30	2194	9.15	2276
26	3.67	1538	4.56	1804	5.37	1989	6.26	2132	7.14	2235	7.96	2296	8.84	2358

MCFZ-A24WV -[E1] : MUZ-A24YV -[E1] Rated frequency 95Hz

CAPACITY:6.4(kW) INPUT:2440(W)

INDOOR DB(°C)	OUTDOOR WB(°C)													
	-10		-5		0		5		10		15		20	
	Q	INPUT	Q	INPUT	Q	INPUT	Q	INPUT	Q	INPUT	Q	INPUT	Q	INPUT
15	4.03	1586	4.86	1903	5.70	2147	6.53	2318	7.36	2464	8.13	2538	8.96	2586
21	3.84	1708	4.61	2025	5.44	2245	6.21	2416	7.04	2538	7.81	2611	8.61	2708
26	3.46	1830	4.29	2147	5.06	2367	5.89	2538	6.72	2660	7.49	2733	8.32	2806

MSZ-A26YV -[E1] : MUZ-A26YV -[E1] Rated frequency 65Hz

CAPACITY:8.1(kW) INPUT:2650(W)

INDOOR DB(°C)	OUTDOOR WB(°C)													
	-10		-5		0		5		10		15		20	
	Q	INPUT	Q	INPUT	Q	INPUT	Q	INPUT	Q	INPUT	Q	INPUT	Q	INPUT
15	5.10	1723	6.16	2067	7.21	2332	8.26	2518	9.32	2677	10.29	2756	11.34	2809
21	4.86	1855	5.83	2200	6.89	2438	7.86	2624	8.91	2756	9.88	2836	10.89	2942
26	4.37	1988	5.43	2332	6.40	2571	7.45	2756	8.51	2889	7.96	2968	10.53	3048

NOTE Q : Total capacity (kW) INPUT : Total power input (W) DB : Dry-bulb temperature WB : Wet-bulb temperature

MUZ-A18YV -E1

MUZ-A24YV -E1

MUZ-A26YV -E1

9-1. Outdoor fan motor control

The fan motor turns ON/OFF, interlocking with the compressor.

[ON] The fan motor turns ON 5 seconds before the compressor starts up.

[OFF] The fan motor turns OFF 15 seconds after the compressor has stopped running.

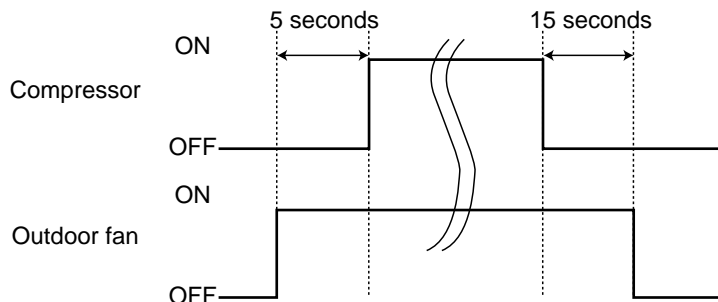

9-2. R.V. coil control

Heating ON

Cooling OFF

Dry OFF

NOTE: The 4-way valve reverses for 5 seconds right before start-up of the compressor.

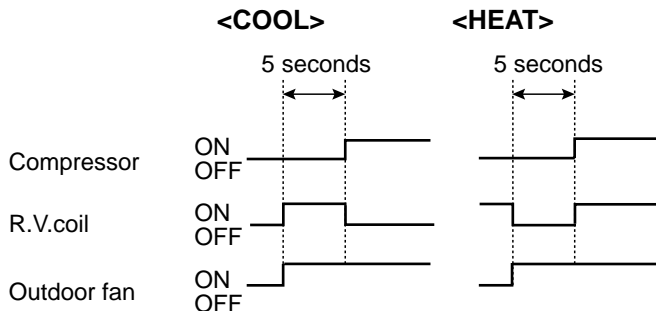

9-3. Relation between main sensor and actuator

Relation between main sensor and actuator.

Sensor	Purpose	Actuator			
		Compressor	LEV	Outdoor fan motor	4-way valve
Discharge temperature thermistor	Protection	○	○		
Indoor pipe temperature thermistor	Defrosting Protection	○	○	○	
Defrost thermistor	Defrosting	○	○	○	○
Fin temperature thermistor	Protection	○		○	
Outdoor heat exchanger temperature	Protection	○	○	○	

MUZ-A18YV -[E1]

MUZ-A24YV -[E1]

MUZ-A26YV -[E1]

10-1. Cautions on troubleshooting

1. Before troubleshooting, check the following:

- 1) Check the power supply voltage.
- 2) Check the indoor/outdoor connecting wire for mis-wiring.

2. Take care the following during servicing.

- 1) Before servicing the air conditioner, be sure to first turn off the remote controller to stop the main unit, and then after confirming the horizontal vane is closed, turn off the breaker and / or disconnect the power plug.
- 2) Be sure to turn OFF the power supply before removing the front panel, the cabinet, the top panel, and the electronic control P.C. board.
- 3) When removing the electrical parts, be careful to the residual voltage of smoothing capacitor.
- 4) When removing the electronic control P.C. board, hold the edge of the board with care NOT to apply stress on the components.
- 5) When connecting or disconnecting the connectors, hold the housing of the connector. DO NOT pull the lead wires.

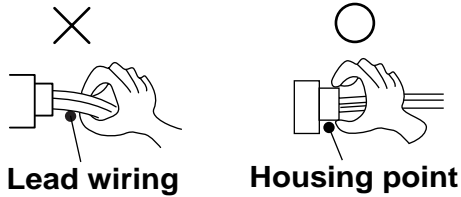

Lead wiring

Housing point

3. Troubleshooting procedure

- 1) First, check if the OPERATION INDICATOR lamp on the indoor unit is flashing on and off to indicate an abnormality. To make sure, check how many times the abnormality indication is flashing on and off before starting service work.
- 2) Before servicing check that the connector and terminal are connected properly.
- 3) If the electronic control P.C. board is supposed to be defective, check the copper foil pattern for disconnection and the components for bursting and discoloration.
- 4) When troubleshooting, refer to the flow chart on page 31 and the check table on page 32 and 33.

10-2. Instruction of troubleshooting

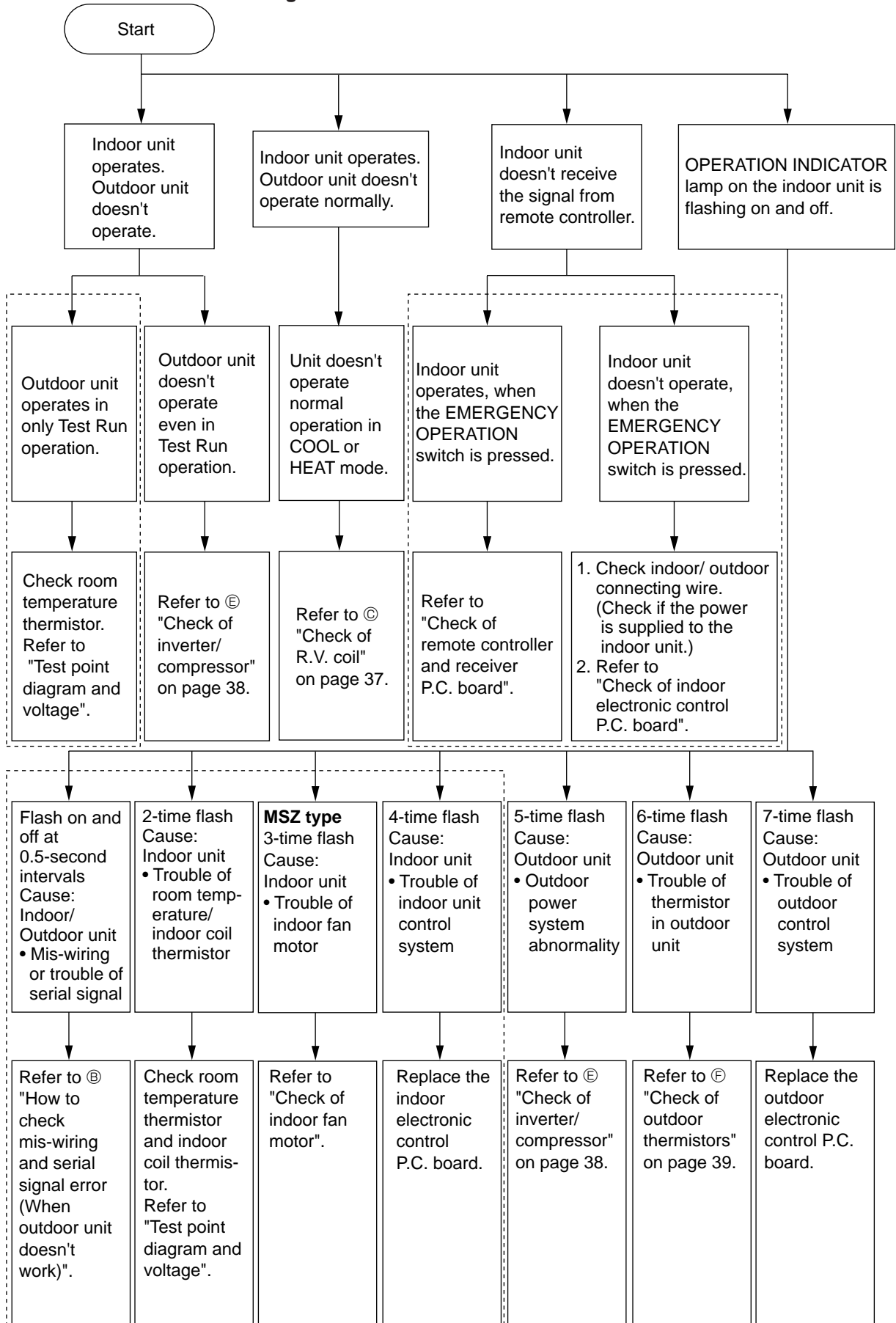

As for indoor unit MSZ type, refer to service manual OB345.

As for indoor unit MCFZ type, refer to service manual OB344 REVISED EDITION - A.



1. Troubleshooting check table

LED 1 (Red)	LED 2 (Yellow)	Error mode
Lighting	Lighting	Normal

Refer to page 35.

Symptom: Outdoor unit does not operate.				
Indication		Abnormal point	Detecting method	Check points
LED 1 (Red)	LED 2 (Yellow)			
Lighting	Twice	Outdoor power system	When the compressor operation has been interrupted by over current protection continuously three times within 1 minute after start-up, or when power factor control module protection or DC control protection is activated three times within 3 minutes after the compressor get started.	<ul style="list-style-type: none"> • Check the inverter/compressor.
Lighting	7 times	Outdoor control system	When the nonvolatile memory data cannot be read properly on the outdoor electronic control P.C. board.	<ul style="list-style-type: none"> • Replace the outdoor electronic control P.C. board.

Symptom: It is repeated that outdoor unit stops and restarts 3 minutes later.				
Indication		Abnormal point	Detecting method	Check points
LED 1 (Red)	LED 2 (Yellow)			
Lighting	3 times	Discharge temperature thermistor	When a short or open circuit occurs in the discharge temperature thermistor during compressor operating.	<ul style="list-style-type: none"> • Check the characteristic of the discharge temperature thermistor. • Check the connector. (CN661)
Lighting	4 times	Fin temperature thermistor	When a short or open circuit occurs in the fin temperature thermistor during compressor operating.	<ul style="list-style-type: none"> • Check the characteristic of the fin temperature thermistor. • Check the connector. (CN3)
		P.C. board temperature thermistor	When a short or open circuit occurs in the P.C. board temperature thermistor during compressor operating.	<ul style="list-style-type: none"> • Replace the outdoor electronic control P.C. board.
Lighting	5 times	Outdoor heat exchanger temperature thermistor	When the outdoor heat exchanger temperature thermistor is short or open while compressor is operating.	<ul style="list-style-type: none"> • Check the characteristic of the high pressure protect thermistor. • Check the connector. (CN661)
Lighting	6 times	Current sensor	When the output from compressor current sensor becomes 25A or more while the compressor is operating.	<ul style="list-style-type: none"> • Check if the connection lead wires of compressor are correctly connected.
Lighting	11 times	Communication error between P.C. boards	When the communication failure between the outdoor electronic control P.C. board and power board occurs twice consecutively.	<ul style="list-style-type: none"> • Check if the connection wires between outdoor electronic control P.C. board and power board are correctly connected.
Lighting	12 times	Zero cross signal error	When the zero cross signal cannot be detected while the compressor is operating.	<ul style="list-style-type: none"> • Check if the connection wires between noise filter P.C. board and power board are correctly connected.
Twice	Goes out	Overcurrent protection	When overcurrent is applied to the power module.	<ul style="list-style-type: none"> • Check the inverter/ compressor. • Check the amount of gas. • Check the indoor/ outdoor air flow for short cycle. • Check the indoor unit air filter for clogging.
3 times	Goes out	Discharge temperature overheat protection	When the discharge temperature thermistor detects 116°C or above. (Protection will be released at 100°C or below.)	<ul style="list-style-type: none"> • Check the amount of gas and the refrigerant cycle. • Check the outdoor unit air passage.
4 times	Goes out	Fin temperature overheat protection	When the fin temperature thermistor detects 87°C or above.	<ul style="list-style-type: none"> • Check the outdoor unit air passage. • Check the outdoor fan motor. • Check the power module.

Symptom: It is repeated that outdoor unit stops and restarts 3 minutes later				
Indication		Abnormal point	Detecting method	Check points
LED 1 (Red)	LED 2 (Yellow)			
4 times	Goes out	P.C. board temperature overheat protection	When the P.C. board temperature thermistor detects 70°C or above.	<ul style="list-style-type: none"> • Check the outdoor unit air passage. • Check the outdoor fan motor. • Replace the outdoor electronic control P.C. board.
5 times	Goes out	High-pressure protection	When the outdoor heat exchanger temperature thermistor detects 69°C or more. When high-pressure switch detects 4MPa or more. (MUZ-A26YV)	<ul style="list-style-type: none"> • Check the outdoor unit air passage. • Check the outdoor fan motor.
8 times	Goes out	Power factor control module protection	When the overcurrent to power factor controller occurs or the output voltage from power factor controller becomes 400V or more.	<ul style="list-style-type: none"> • Check the input voltage. • Check the inverter.
9 times	Goes out	DC voltage protection	When it's detected that DC voltage becomes 200V or less, or reaches 400V or more.	<ul style="list-style-type: none"> • Check the voltage of power supply. • Check the inverter.
11 times	Goes out	Connectivity of indoor and outdoor unit	When the unusual signal is transmitted from the indoor unit.	<ul style="list-style-type: none"> • Check if the indoor unit can be connected with the outdoor unit.
13 times	Goes out	Fan motor protection	When the fan motor current is 2A or more, or when the abnormality is detected in the feedback signal from fan motor.	<ul style="list-style-type: none"> • Check the outdoor fan motor. • Check the fan motor connector.



Symptom: Outdoor unit operates (The compressor operates at reduced frequency)				
Indication		Abnormal point	Detecting method	Check points
LED 1 (Red)	LED 2 (Yellow)			
Once	Lighting	Current protection	When the outdoor unit input current exceeds 14.5A.	These symptoms do not mean any abnormality of the product, but check the following points. <ul style="list-style-type: none"> • Air filter clogging • Amount of gas • Short cycle of indoor/outdoor air flow
Twice	Lighting	High-pressure protection	When the indoor gas pipe temperature exceeds 55°C during heating.	
Twice	Lighting	Defrosting in cooling	When the indoor gas pipe temperature falls to 6°C or below during cooling.	
3 times	Lighting	Discharge temperature protection	When the discharge temperature exceeds 104°C.	
4 times	Lighting	Low discharge temperature protection	When the state with low discharge temperature of which 37°C or below in COOL and 35°C or below in HEAT lasts for 20 minutes.	
5 times	Lighting	High-pressure protection	When outdoor heat exchanger temperature thermistor detects 58°C or more.	

Symptom: Outdoor unit operates.				
Indication		Abnormal point	Detecting method	Check points
LED 1 (Red)	LED 2 (Yellow)			
Lighting	5 times	Defrost thermistor	When a short or open circuit occurs in the defrost thermistor during heating.	<ul style="list-style-type: none"> • Check the characteristic of the defrost temperature thermistor. • Check the connector. (CN661)
11 times	Lighting	Initial-setting	When the initial-setting information from an indoor unit is now being read.	
9 times	Lighting	Service mode	When the unit operates EMERGENCY OPERATION.	

2. Trouble criterion of main parts

MUZ-A18YV -E1

MUZ-A24YV -E1

MUZ-A26YV -E1

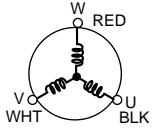
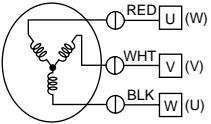
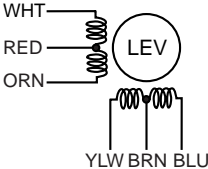
Part name	Check method and criterion			
Defrost thermistor/ Outdoor heat exchanger temperature thermistor	Measure the resistance using a tester. (Part temperature : -10°C ~ 40°C)			
	Normal		abnormal	
	5kΩ ~ 55kΩ		Open or short-circuit	
Discharge temperature thermistor	Measure the resistance using a tester, after warming up the thermistor by holding by hand. (Part temperature : 20°C ~ 40°C)			
	Normal		abnormal	
	100kΩ ~ 250kΩ		Opened or short-circuit	
Fin temperature thermistor	Measure the resistance using a tester. (Part temperature : 10°C ~ 40°C)			
	Normal		abnormal	
	25kΩ ~ 100kΩ		Open or short-circuit	
Compressor 	Measure the resistance between terminals using a tester. (Winding temperature : -10°C ~ 40°C)			
	Normal		abnormal	
	MUZ-A18/A24YV	MUZ-A26YV	Open or short-circuit	
	0.40Ω ~ 0.49Ω	1.29Ω ~ 1.49Ω		
Outdoor fan motor 	Measure the resistance between lead wires using a tester. (Part temperature : -10°C ~ 40°C)			
	Color of lead wire	Normal	abnormal	
	RED - BLK	13.4Ω ~ 16.4Ω	Open or short-circuit (Not including WHT - ORN)	
	BLK - WHT			
	WHT - RED			
R. V. coil	Measure the resistance using a tester. (Part temperature : -10°C ~ 40°C)			
	Normal		abnormal	
	2.6kΩ ~ 3.3kΩ		Open or short-circuit	
Linear expansion valve 	Measure the resistance using a tester. (Part temperature : -10°C ~ 40°C)			
	Color of lead wire	Normal	Abnormal	
	WHT - RED	37.4Ω ~ 53.9Ω	Open or short-circuit	
	RED - ORN			
	YLW - BRN			
	BRN - BLU			
High pressure switch (HPS) MUZ-A26YV	MUZ-A26YV			
	Pressure		Normal	abnormal
	Operation OFF		Short	Other than those listed at left
	HPS1	3.7 ± 0.15MPa		
		4.8 ± 0.15MPa	Open	

Outdoor unit does not operate. (LED display: display OFF)

Ⓐ Check of power supply

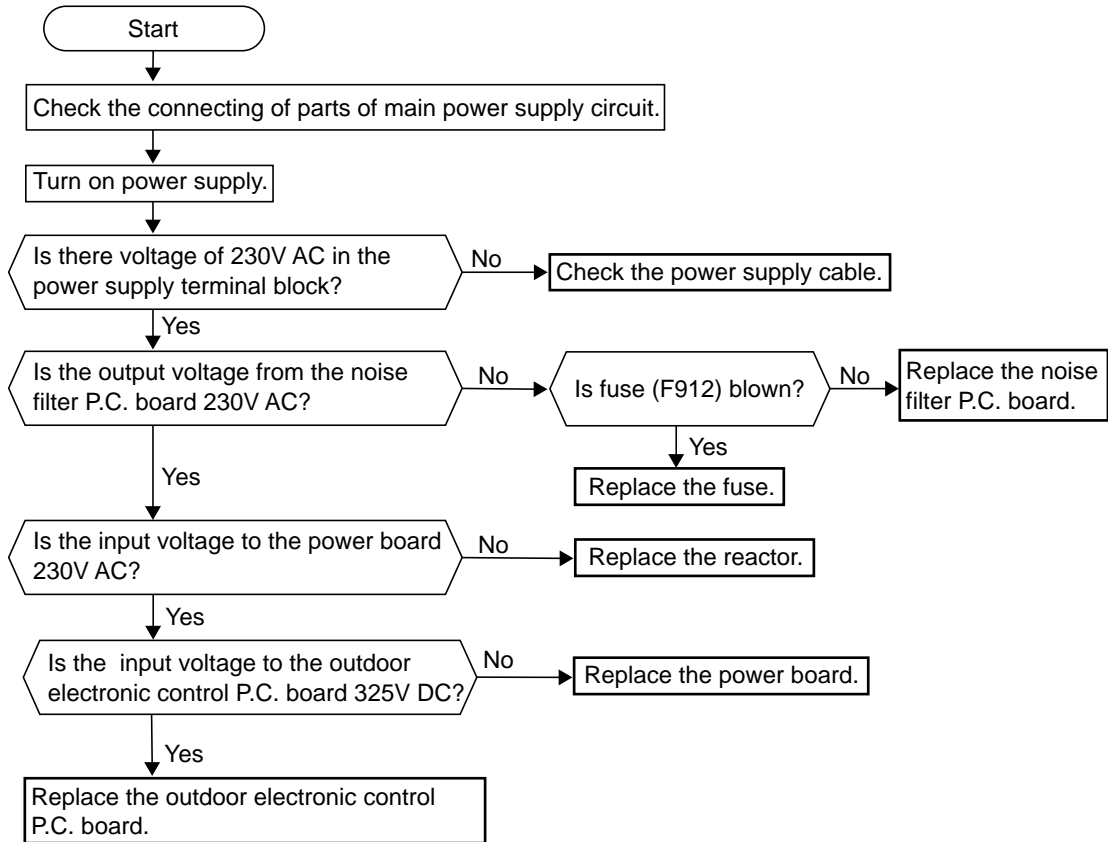

When OPERATION INDICATOR lamp flashes ON and OFF in every 0.5-second.
Outdoor unit doesn't operate. (LED display: Both LED1 and LED2 lighting)

B How to check mis-wiring and serial signal error (when outdoor unit does not work)

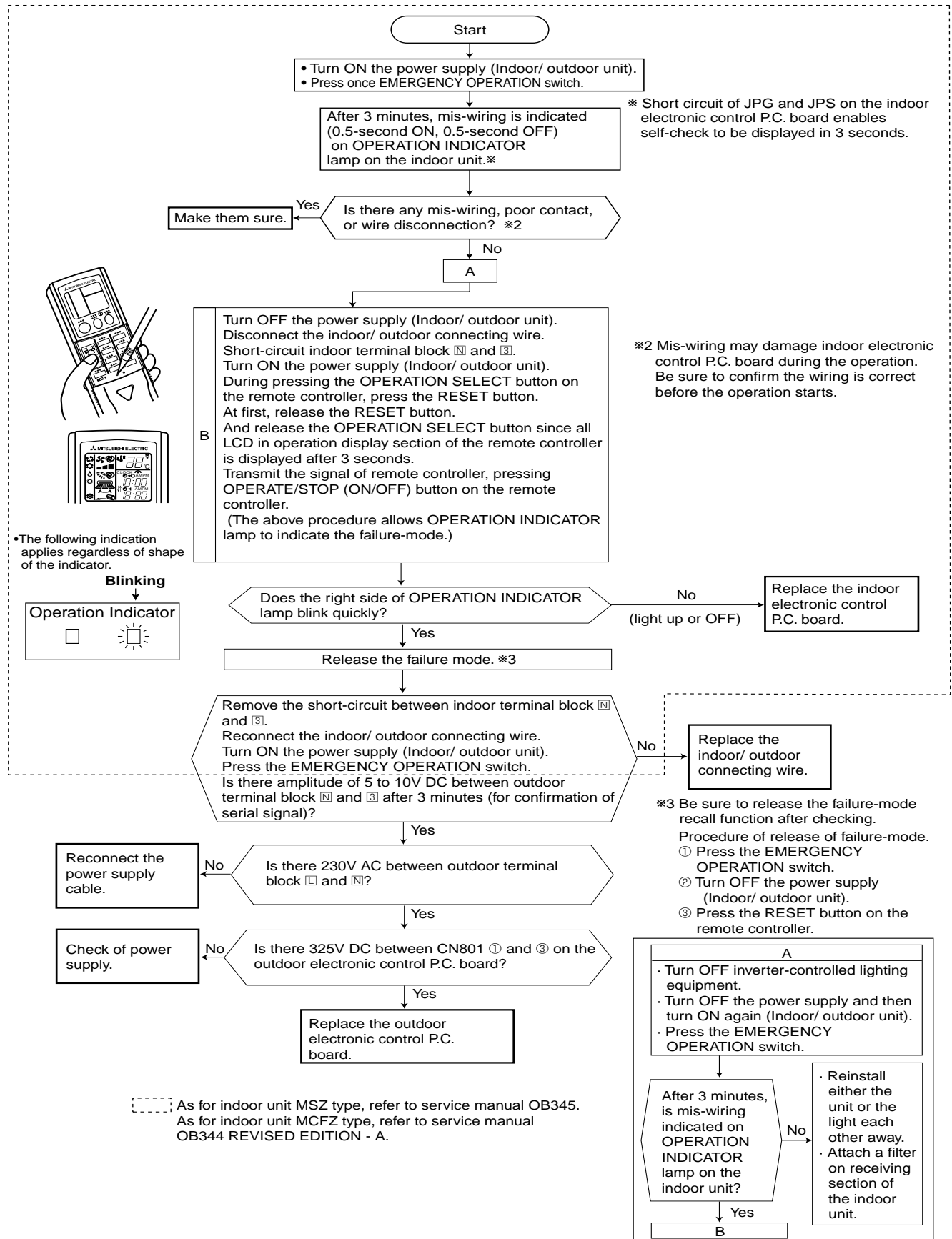

The cooling operation or heating operation does not operate. (LED display: Both LED1 and LED2 lighting)

© Check of R.V. coil

• When heating operation does not work.

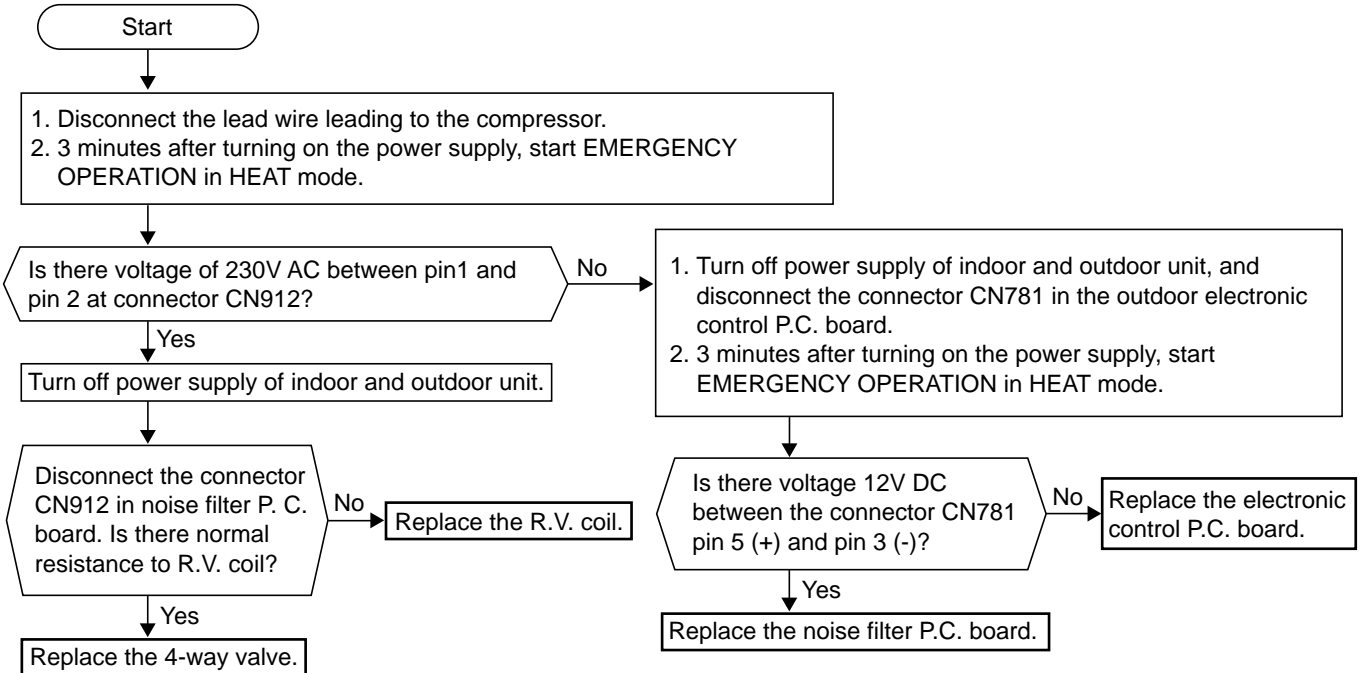

• When cooling operation does not work.

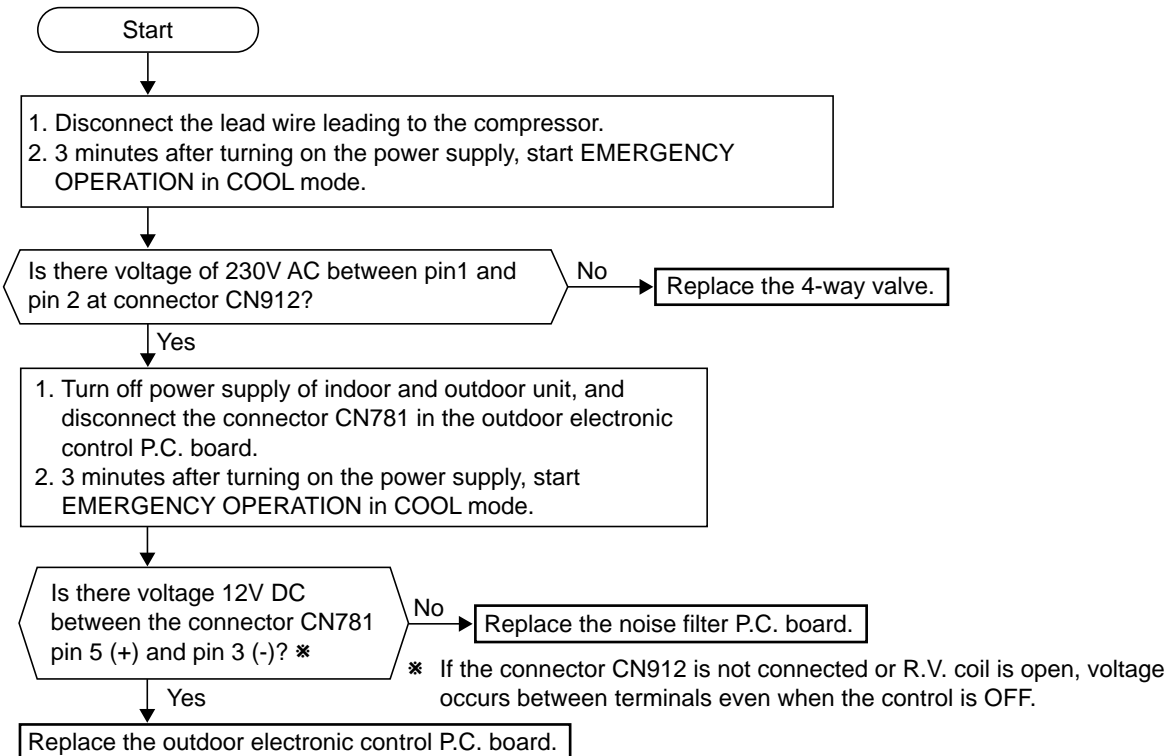

- When cooling, heat exchanger of non-operating indoor unit frosts.
- When heating, non-operating indoor unit get warm.

Ⓣ Check of LEV

LED display:

LED1	LED2
Lighting	Lighting
6 time	Goes out

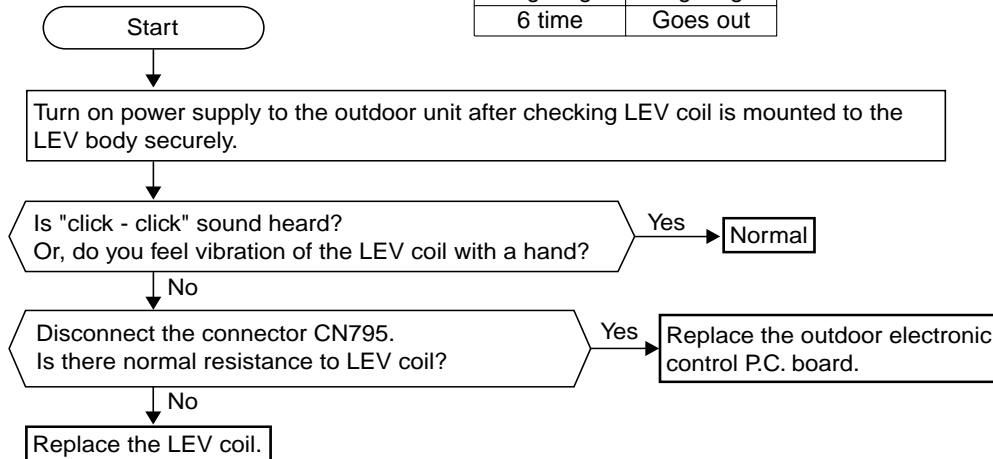

When OPERATION INDICATOR lamp flashes 5-time.

- When heating, room does not get warm.
- When cooling, room does not get cool.

Ⓤ Check of inverter/ compressor

LED display:

LED1	LED2
Lighting	Lighting
Lighting	Twice
Twice	Goes out

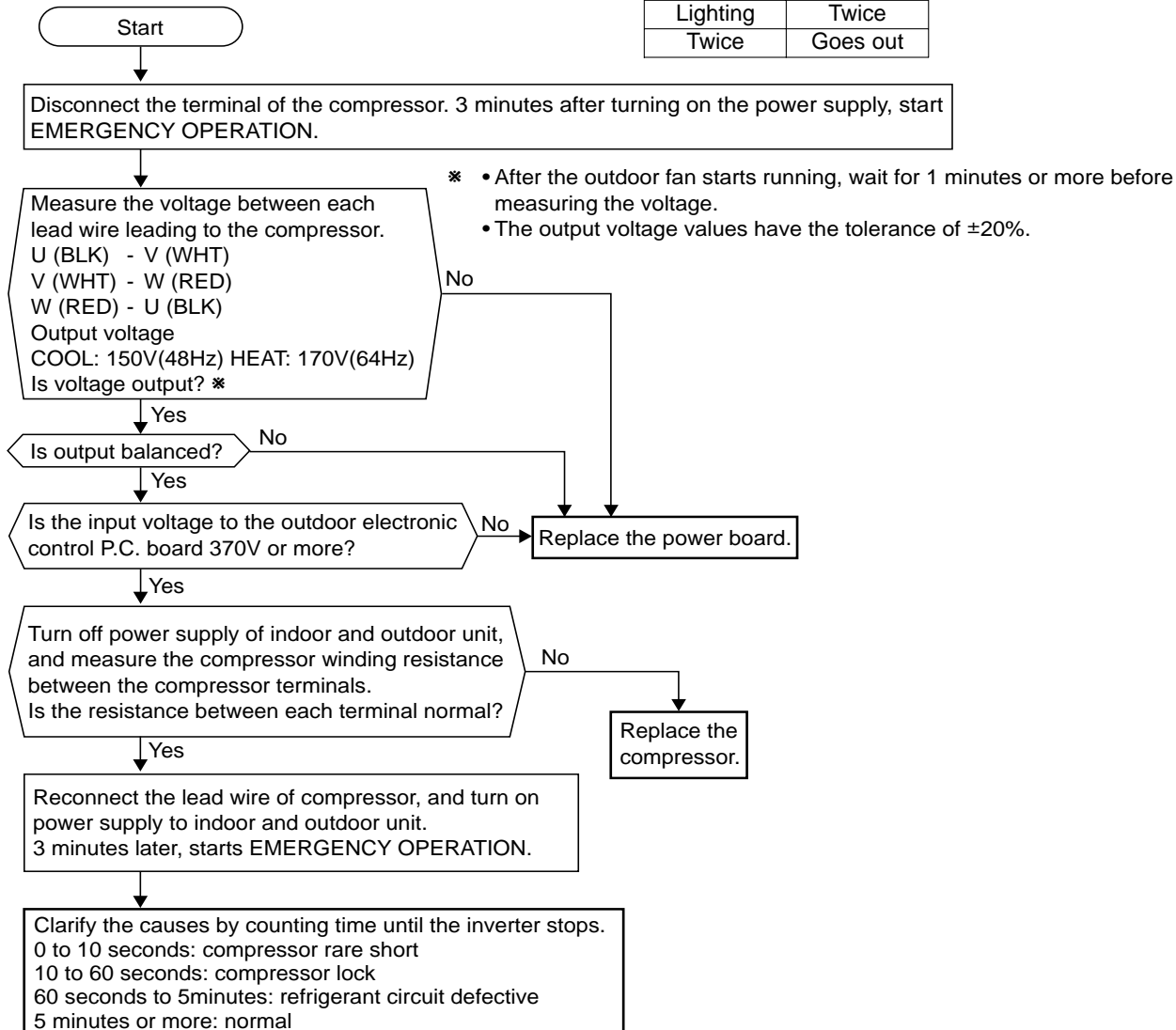

- When OPERATION INDICATOR lamp flashes 6-time.
- When thermistor is abnormal. (When the LED display is a table below.)

Ⓔ Check of outdoor thermistors

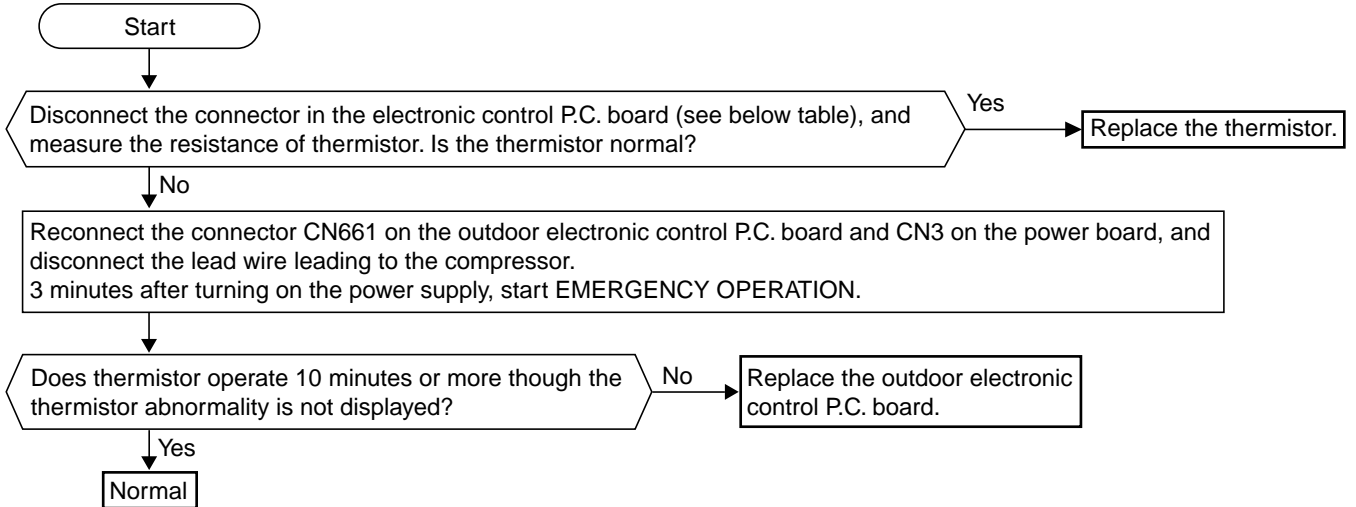

Thermistor	Symbol	Connector, Pin No.
Discharge temperature thermistor	RT61	Between CN661 pin3 and pin4
Defrost thermistor	RT62	Between CN661 pin1 and pin2
Outdoor heat exchanger temperature thermistor	RT68	Between CN661 pin7 and pin8
Fin temperature thermistor	RT65	Between CN3 pin1 and pin2

- Fan motor does not operate or stops operating shortly after starting the operation.

Ⓕ Check of outdoor fan motor

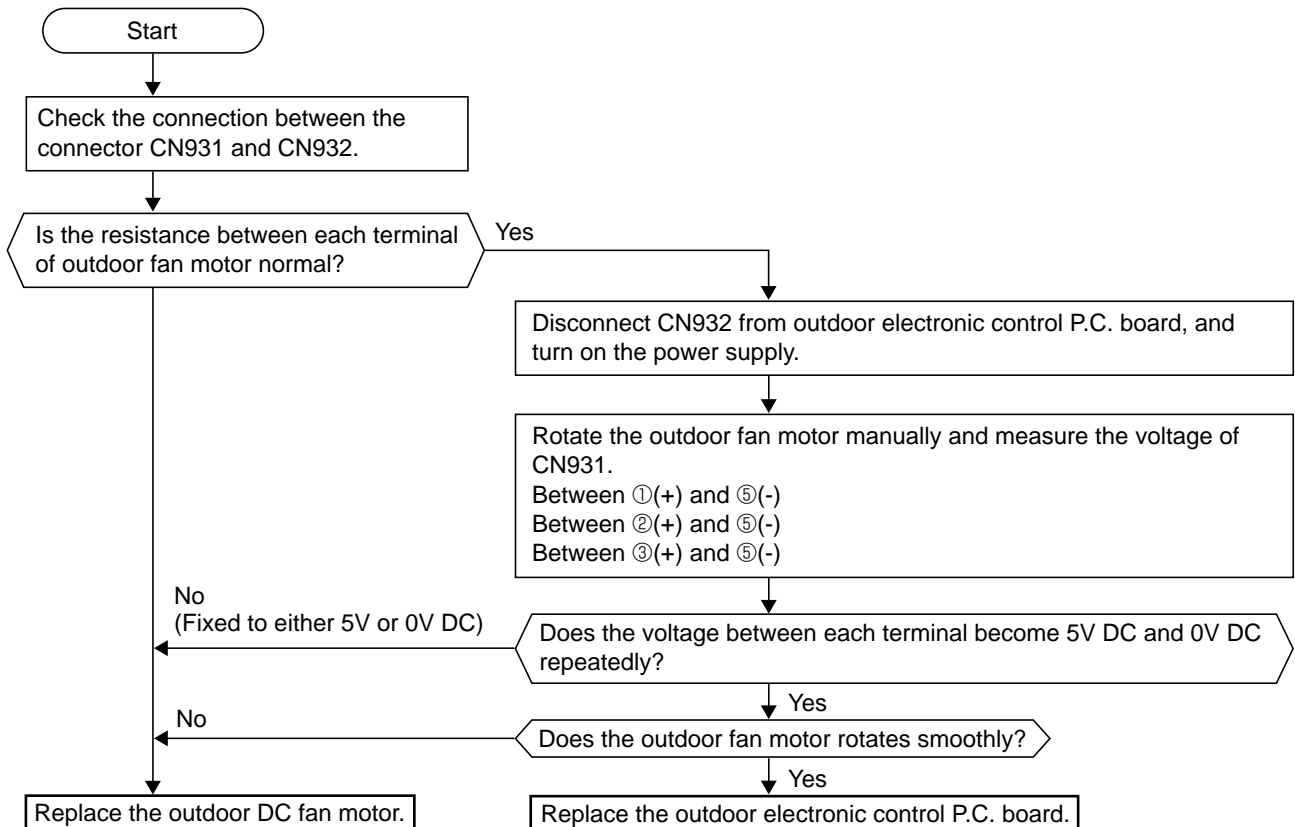

• When the operation frequency does not go up from lowest frequency.

⊕ Check of HPS

MUZ-A26YV

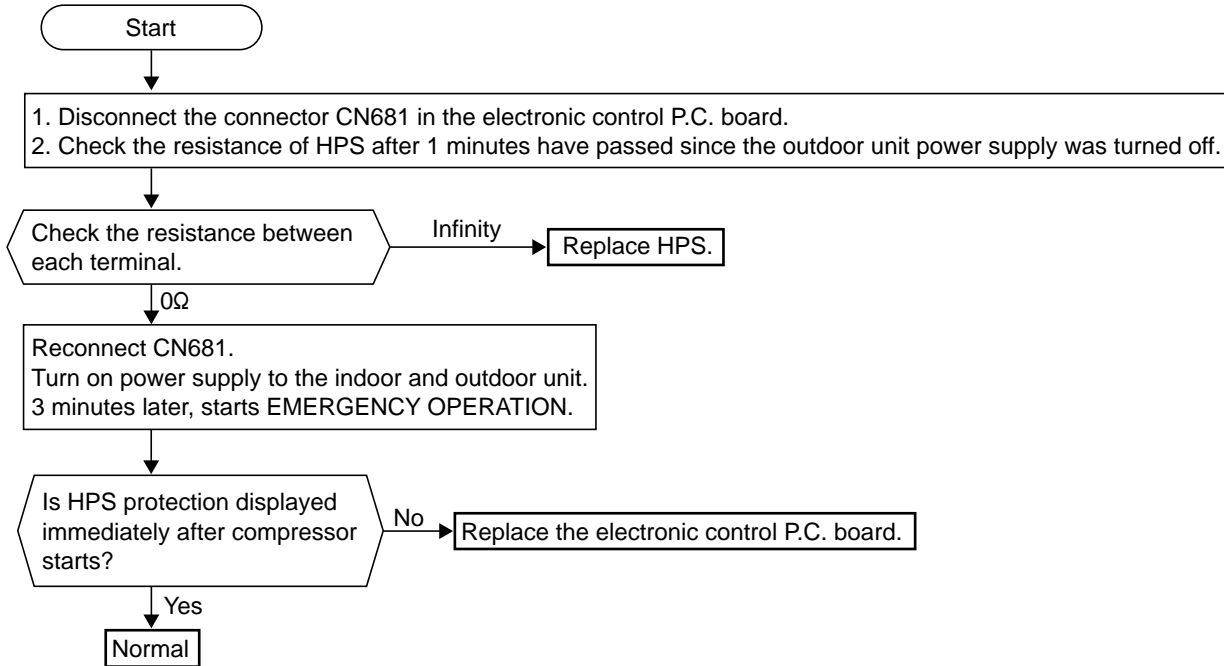

MUZ-A18YV -E1 MUZ-A24YV -E1 MUZ-A26YV -E1
Outdoor electronic control P.C. board

Defrost temperature thermistor (RT62)
 Fin temperature thermistor (RT65) Outdoor heat exchanger temperature thermistor (RT68)

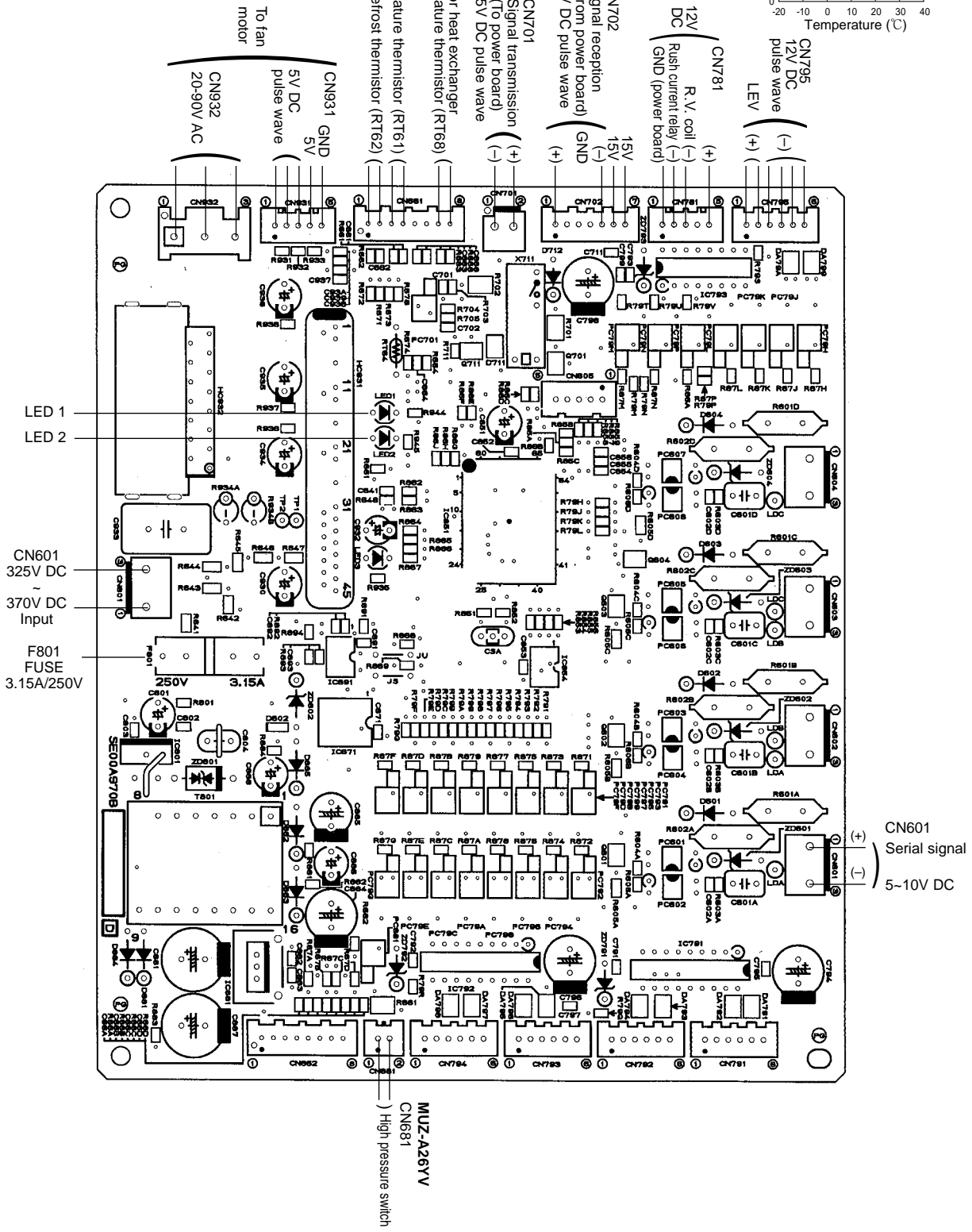
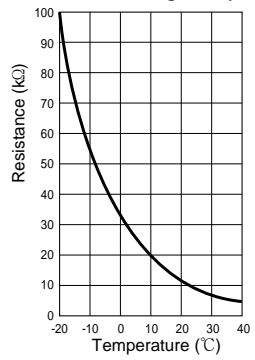
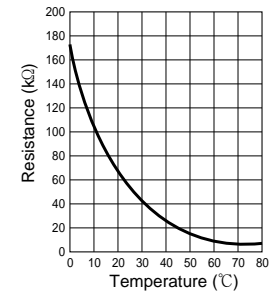
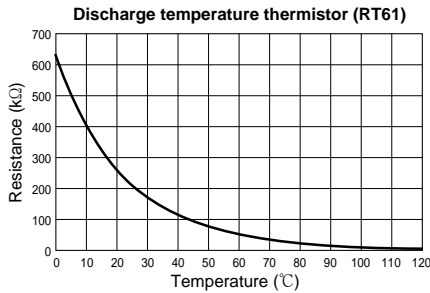

MUZ-A18YV -E1

MUZ-A24YV -E1

MUZ-A26YV -E1

Noise filter P.C. board

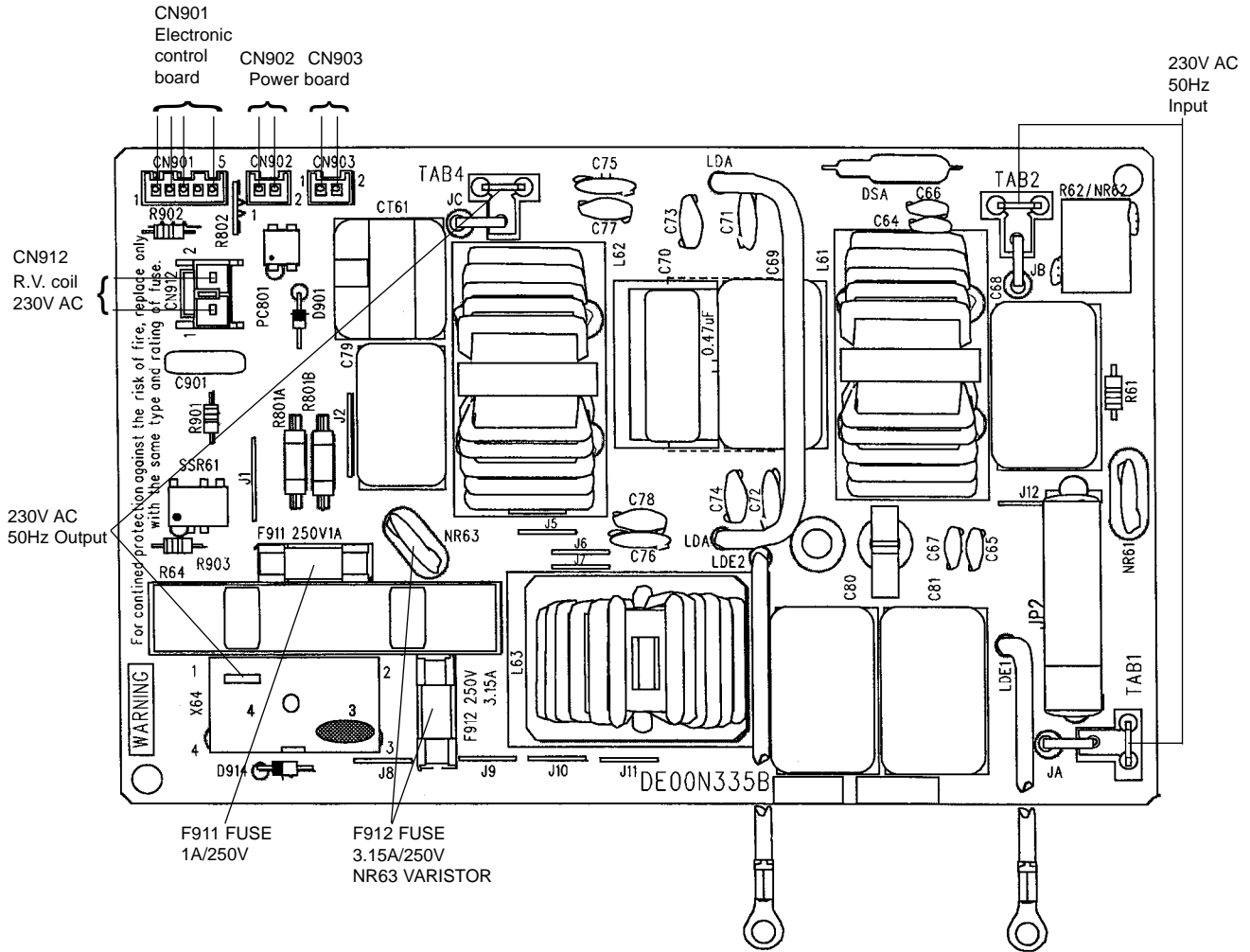

MUZ-A18YV -E1
MUZ-A24YV -E1
MUZ-A26YV -E1
Power board

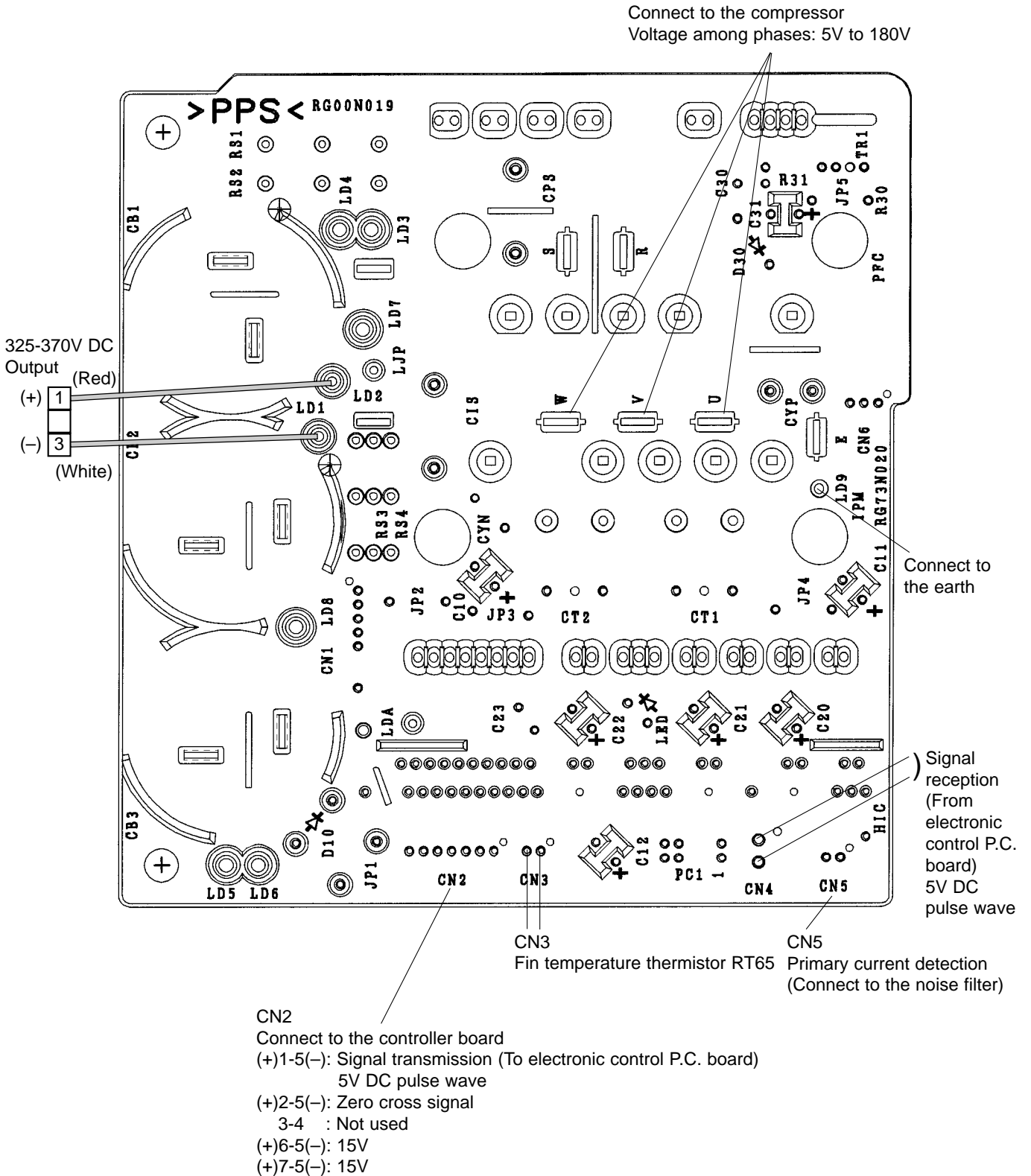

<"Terminal with lock mechanism" Detaching points>

In case of terminal with lock mechanism, detach the terminal as shown below.
 There are two types (Refer to (1) and (2)) of the terminal with lock mechanism.
 The terminal with no lock mechanism can be removed by pulling it out.
 Check the shape of the terminal and work.

(1) Slide the sleeve and check if there is a locking lever or not.

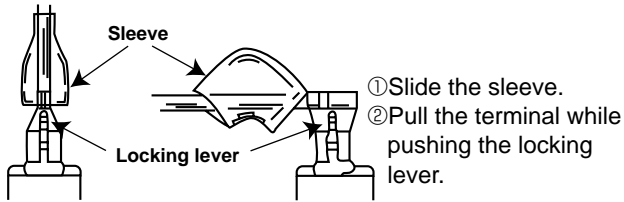

(2) The terminal with this connector is a terminal with lock mechanism

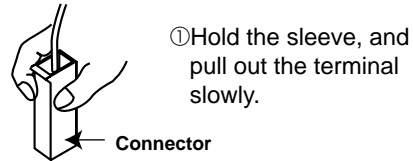

MUZ-A18YV -[E1] MUZ-A24YV -[E1] MUZ-A26YV -[E1]
OUTDOOR UNIT

NOTE :
 These photos are MUZ-A26YV.
 Other models are almost the same as MUZ-A26YV.

OPERATING PROCEDURE	PHOTOS
<p>1. Removing the cabinet</p> <ol style="list-style-type: none"> (1) Remove the screws of the service panel. (2) Remove the screws of the top panel. (3) Remove the screw of the valve cover. (4) Remove the service panel. (5) Remove the top panel. (6) Remove the valve cover. (7) Remove the screws of the cabinet. (8) Remove the cabinet. (9) Remove the screws of the back panel. (10) Remove the back panel. <p>Photo 3</p> <p>Screw of the motor support</p> <p>Screws of the back panel</p> <p>Set screws of the back panel</p>	<p>Photo 1</p> <p>Screw of the top panel</p> <p>Screws of the cabinet</p> <p>Screws of the cabinet</p> <p>Photo 2</p> <p>Screw of the service panel</p> <p>Screws of the top panel</p> <p>Screws of the cabinet</p> <p>Screw of the valve cover</p>



OPERATING PROCEDURE

4. Removing the defrost thermistor, discharge temperature thermistor and outdoor heat exchanger temperature thermistor

- (1) Remove the top panel, cabinet and service panel. (Refer to 1.)
- (2) Remove the back panel. (Refer to 1.)
- (3) Remove the inverter assembly. (Refer to 2.)
- (4) Pull out the defrost thermistor from its holder. (Photo 6)
- (5) Pull out the discharge temperature thermistor from its holder. (Photo 5)
- (6) Pull out the outdoor heat exchanger temperature thermistor from its holder. (Photo 6)

PHOTOS

Photo 5

Discharge temperature thermistor



Photo 6

Outdoor heat exchanger temperature thermistor

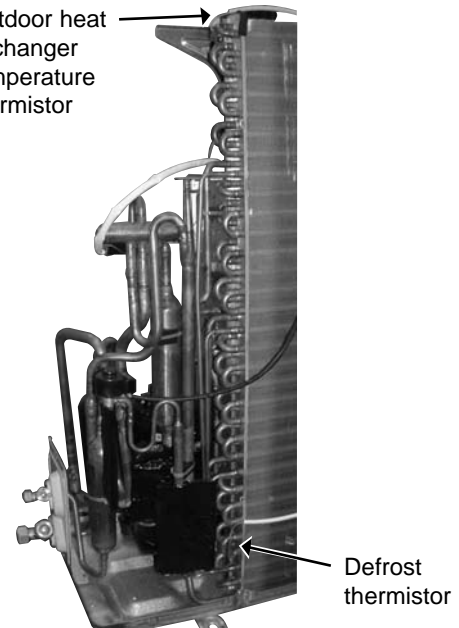

5. Removing outdoor fan motor

- (1) Remove the top panel, cabinet and service panel. (Refer to 1.)
- (2) Remove the back panel. (Refer to 1.)
- (3) Remove the inverter assembly. (Refer to 2.)
- (4) Remove the propeller.
- (5) Remove the screws fixing the fan motor.
- (6) Remove the fan motor.

Photo 7

Propeller Screws of the outdoor fan motor

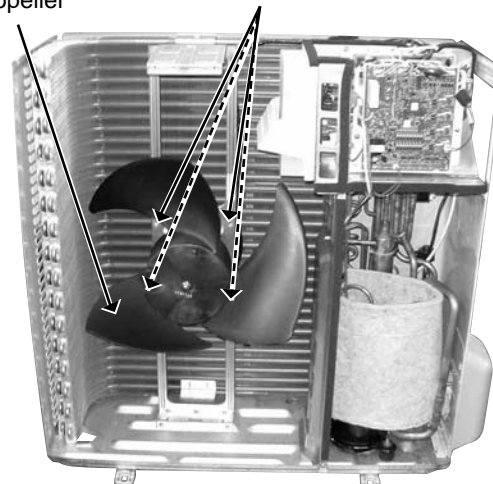

OPERATING PROCEDURE

6. Removing the compressor and 4-way valve

(1) Remove the top panel, cabinet and service panel.
(Refer to 1.)

(2) Remove the back panel. (Refer to 1.)

(3) Remove the inverter assembly. (Refer to 2.)

(4) Recover gas from the refrigerant circuit.

NOTE: Recover gas from the pipes until the pressure gauge shows 0 kg/cm² (0 MPa).

(5) Detach the welded part of the suction and the discharge pipe connected with compressor. (Photo 9)

(6) Remove the compressor nuts.

(7) Remove the compressor.

(8) Detach the welded part of 4-way valve and pipe. (Photo 8)

PHOTOS

Photo 8

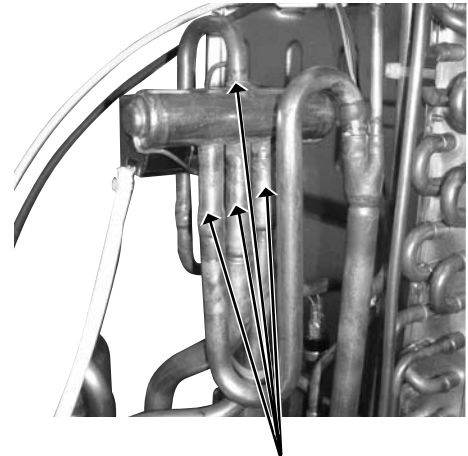

Welded parts of 4-way valve

Photo 9

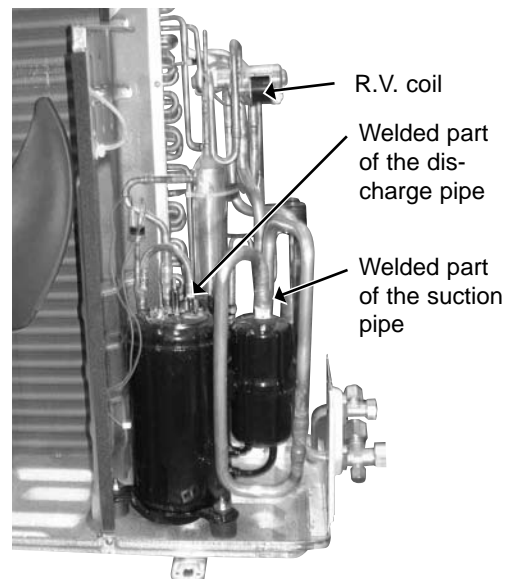

7. Removing the reactor

(1) Remove the top panel. (Refer to 1.)

(2) Disconnect the reactor lead wire.

(3) Remove the screws of the reactor, and remove the reactor.

Photo 10

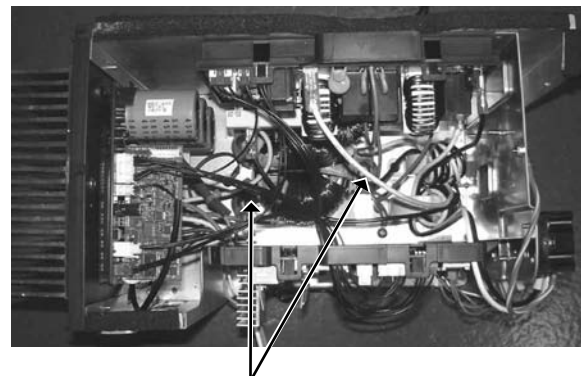

Screws of the reactor

MUZ-A18YV -E1 MUZ-A24YV -E1 MUZ-A26YV -E1

12-1. OUTDOOR UNIT STRUCTURAL PARTS, ELECTRICAL PARTS AND FUNCTIONAL PARTS

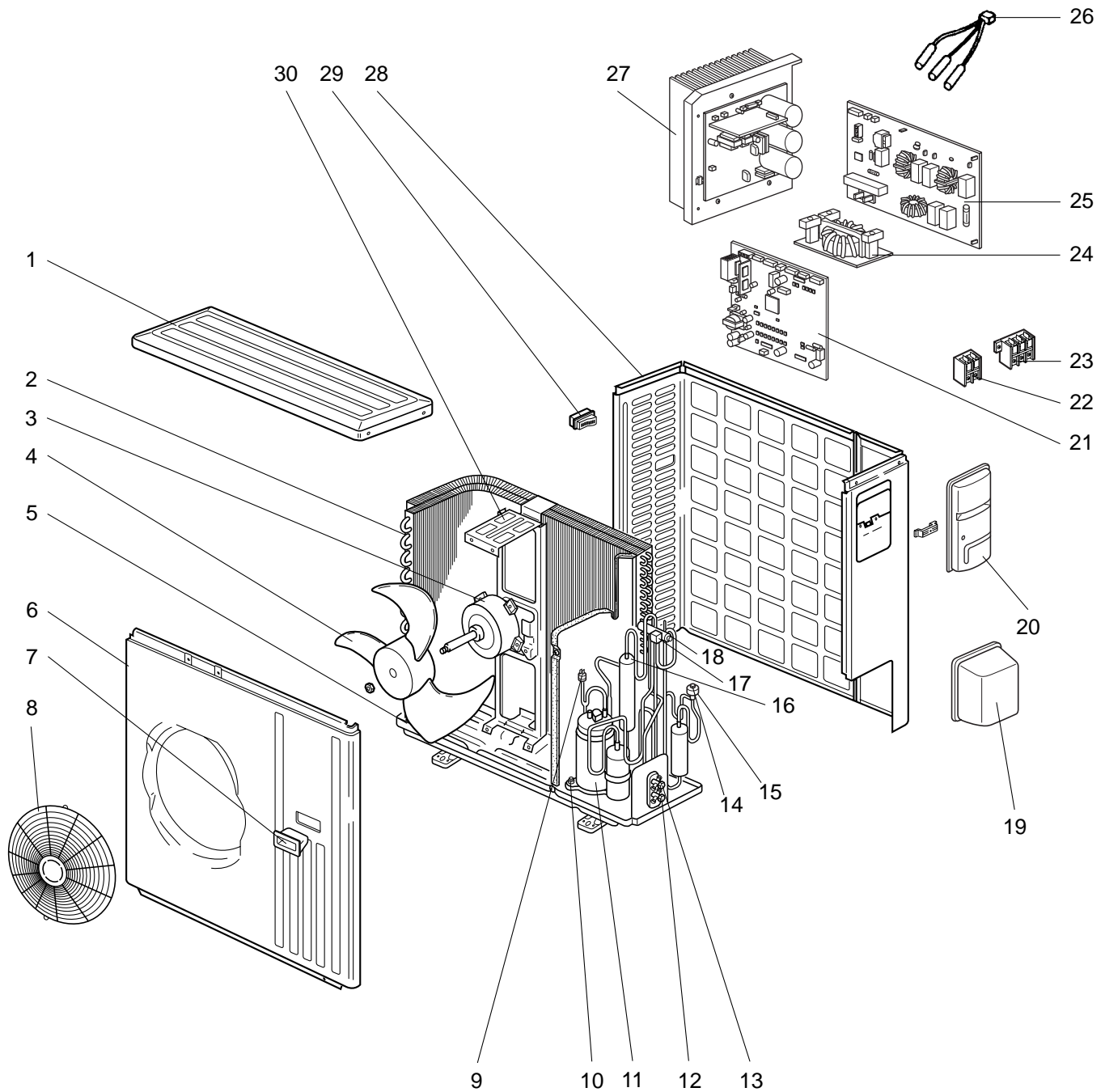

These figures show about MUZ-A26YV.

MUZ-A18YV -^[E1] MUZ-A24YV -^[E1] MUZ-A26YV -^[E1]

12-1. OUTDOOR UNIT STRUCTURAL PARTS, ELECTRICAL PARTS AND FUNCTIONAL PARTS

Part numbers that are circled are not shown in the illustration.

No.	Part No.	Part Name	Symbol in Wiring Diagram	Q'ty/unit			Remarks
				MUZ-A18 YV - ^[E1]	MUZ-A24 YV - ^[E1]	MUZ-A26 YV - ^[E1]	
1	E02 819 297	TOP PANEL		1	1	1	
2	E02 851 630	OUTDOOR HEAT EXCHANGER		1	1		
	E02 853 630	OUTDOOR HEAT EXCHANGER				1	
3	E02 851 301	OUTDOOR FAN MOTOR	MF	1	1	1	PM8H60- □□
4	E02 851 501	PROPELLER		1	1	1	
5	E02 851 290	BASE		1	1		
	E02 853 290	BASE				1	
6	E02 819 232	CABINET		1	1	1	
7	E02 819 009	HANDLE		1	1	1	
8	E02 819 521	FAN GUARD		1	1	1	
9	E02 853 646	HIGH PRESSURE SWITCH	HPS			1	
10	E02 065 506	COMPRESSOR RUBBER SET		3	3		3RUBBERS/SET
	E02 853 506	COMPRESSOR RUBBER SET				3	3RUBBERS/SET
11	E02 851 900	COMPRESSOR	MC	1	1		SNB130FLDH
	E02 853 900	COMPRESSOR	MC			1	TNB220FMCH
12	E02 851 661	STOP VALVE(GAS)		1			φ12.7
	E02 819 661	STOP VALVE(GAS)			1	1	φ15.88
13	E02 821 662	STOP VALVE(LIQUID)		1	1		φ6.35
	E02 822 662	STOP VALVE(LIQUID)				1	φ9.52
14	E02 851 640	EXPANSION VALVE		1	1		
	E02 853 640	EXPANSION VALVE				1	
15	E02 851 493	EXPANSION VALVE COIL	LEV	1	1	1	
16	E02 853 299	OIL SEPARATOR				1	
17	E02 851 490	R.V. COIL	21S4	1	1	1	
18	E02 679 961	4-WAY VALVE		1	1	1	
19	E02 819 650	VALVE COVER		1	1	1	
20	E02 819 245	SERVICE PANEL		1	1	1	
21	E02 851 450	OUTDOOR ELECTRONIC CONTROL P.C. BOARD		1			
	E02 852 450	OUTDOOR ELECTRONIC CONTROL P.C. BOARD			1		
	E02 853 450	OUTDOOR ELECTRONIC CONTROL P.C. BOARD				1	
22	E02 836 374	TERMINAL BLOCK	TB2	1	1	1	2P
23	E02 823 375	TERMINAL BLOCK	TB1	1	1	1	3P
24	E02 851 337	REACTOR	L	1	1	1	
25	E02 851 444	NOISE FILTER P.C. BOARD		1	1	1	
26	E02 851 308	THERMISTOR SET	RT61,RT62,RT68	1	1	1	DISCHARGE, DEFROST OUTDOOR HEAT EXCHANGER
27	E02 851 440	POWER BOARD		1	1	1	Including heat sink and RT65
28	E02 819 233	BACK PANEL(OUT)		1	1	1	
29	E02 817 009	HANDLE		1	1	1	
30	E02 851 515	MOTOR SUPPORT		1	1	1	
③①	E02 127 382	FUSE	F801	1	1	1	250V/3.15A
③②	E02 737 382	FUSE	F911	1	1	1	250V/1A
③③	E02 735 385	FUSE & VARISTOR	F912,NR63	1	1	1	250V/3.15A
③④	E02 851 936	CAPILLARY TUBE(TAPER PIPE)		1	1		φ3.6xφ2.4x50
	E02 853 936	CAPILLARY TUBE(TAPER PIPE)				1	φ3.6xφ2.4x50
	E02 861 936	CAPILLARY TUBE				1	φ1.8xφ0.6x1000

MUZ-A18YV -[E1]

MUZ-A24YV -[E1]

MUZ-A26YV -[E1]

12-2. ACCESSORY

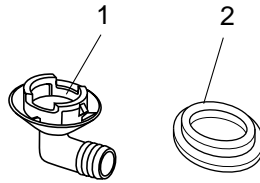

No.	Part No.	Part Name	Symbol in Wiring Diagram	Q'ty/unit			Remarks
				MUZ-A18 YV -[E1]	MUZ-A24 YV -[E1]	MUZ-A26 YV -[E1]	
1	E02 817 704	DRAIN SOCKET		1	1	1	
2	E02 444 705	DRAIN CAP		2	2	2	φ33



HEAD OFFICE: MITSUBISHI DENKI BLDG., 2-2-3, MARUNOUCHI, CHIYODA-KU, TOKYO100-8310, JAPAN

© Copyright 2004 MITSUBISHI ELECTRIC ENGINEERING CO.,LTD

Distributed in Jun. 2004. No. OB346 REVISED EDITION - A 6

Distributed in Apr. 2004. No. OB346 6

Made in Japan

New publication, effective Jun. 2004

Specifications subject to change without notice.