

# Air Conditioning

## Product Information

### MSZ-FH25VE : High COP Inverter Heat Pump

R410A Wall Mounted System



The MSZ-FH series is our most energy efficient M Series wall mounted unit to date. These high efficiency models feature the Plasma Quad filter system. They also offer industry leading noise levels and have a distinctively styled front panel that not only looks appealing but also helps to make cleaning of the unit easier. Also incorporated is a '3D i-see Sensor', providing even temperature distribution and further reducing energy consumption.

## FEATURES



### INDOOR

Heating Capacity (kW) (nominal)	3.2 (1.8 - 5.5)
Cooling Capacity (kW) (nominal)	2.5 (1.4 - 3.5)
Heating Capacity (kW) (UK)	2.65 (1.49 - 4.57)
Cooling Capacity (kW) (UK)	2.48 (1.38 - 3.47)
SHF (nominal and UK)	0.95
COP / EER (nominal)	5.52 / 5.15
SCOP / SEER	5.1 / 9.1
Energy Efficiency Class - Heating / Cooling	A+++ / A+++
Airflow (m³/min) (Heating) - Si-Lo-Mi-Hi-SupHi	4 - 4.7 - 6.4 - 9.2 - 13.2
Airflow (m³/min) (Cooling) - Si-Lo-Mi-Hi-SupHi	3.9 - 4.7 - 6.3 - 8.6 - 11.6
Pipe Size Gas (mm [in])	9.52 (3/8)
Pipe Size Liquid (mm [in])	6.35 (1/4)
Sound Pressure Level (dBA) Heating - Si-Lo-Mi-Hi-SupHi	20 - 24 - 29 - 36 - 44
Sound Pressure Level (dBA) Cooling - Si-Lo-Mi-Hi-SupHi	20 - 23 - 29 - 36 - 42
Sound Power Level (dBA) Cooling	58
Dimensions (mm) Width x Depth x Height	925 x 234 x 305
Weight (kg)	13.5
Electrical Supply	FED BY OUTDOOR UNIT
Phase	SINGLE
Fuse Rating (BS88) - HRC (A)	6
Interconnecting Cable No. Cores	4

### OUTDOOR

Sound Pressure Level (dBA) Heating / Cooling	49 / 46
Sound Power Level (dBA) Cooling	60
Weight (kg)	37
Dimensions (mm) Width x Depth x Height	800 x 285 x 550
Electrical Supply	220-240V, 50HZ
Phase	SINGLE
System Power Input (kW) - Heating / Cooling (nominal)	0.58 / 0.485
System Power Input (kW) - Heating / Cooling (UK)	0.52 / 0.4
Starting Current (A)	2.9
System Running Current (A) [MAX] - Heating / Cooling	2.9 / 2.6 [9.6]
Fuse Rating (BS88) - HRC (A)	10
Mains Cable No. Cores	3
Max Pipe Length (m)	20
Max Height Difference (m)	12
Charge R410A (kg) - (pre charged length)	1.15 (7)

### DIMENSIONS

MSZ-FH

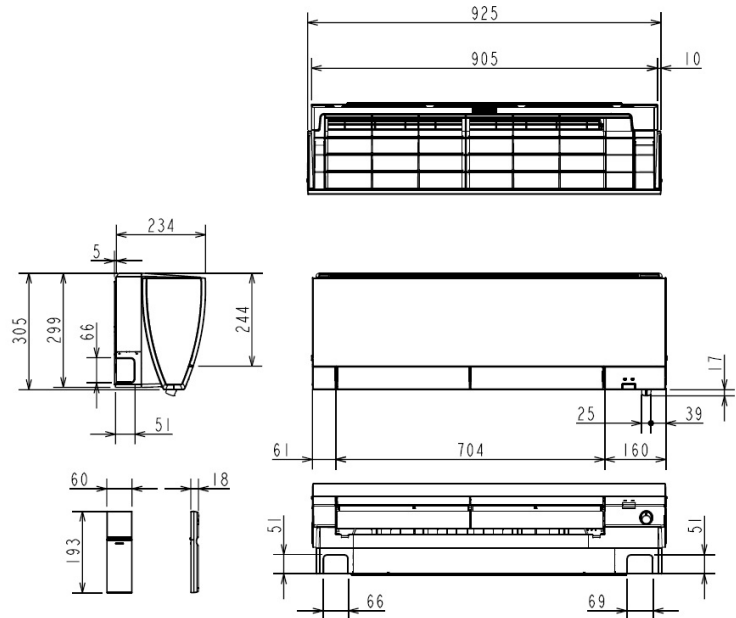

### DIMENSIONS

MUZ-FH

