

Revision A:

- The fan guard for MUZ-FD50VABH- [E1] has been changed.

Please void OBB519.

OUTDOOR UNIT PARTS CATALOG

No. OBB519
REVISED EDITION-A

Models

- MUZ-FD25VABH - [E1]**
MUZ-FD35VABH - [E1]
MUZ-FD50VABH - [E1]

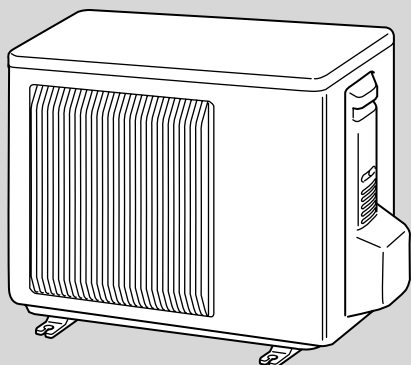

MUZ-FD25/35

CONTENTS

1. RoHS PARTS LIST..... 2

SERVICE MANUAL (OBH519)

NOTE:

RoHS compliant products have <G> mark on the spec name plate.



Revision A:

- The fan guard for MUZ-FD50VABH- [E1] has been changed.

1

RoHS PARTS LIST

MUZ-FD25VABH MUZ-FD35VABH

1-1. OUTDOOR UNIT STRUCTURAL PARTS AND FUNCTIONAL PARTS

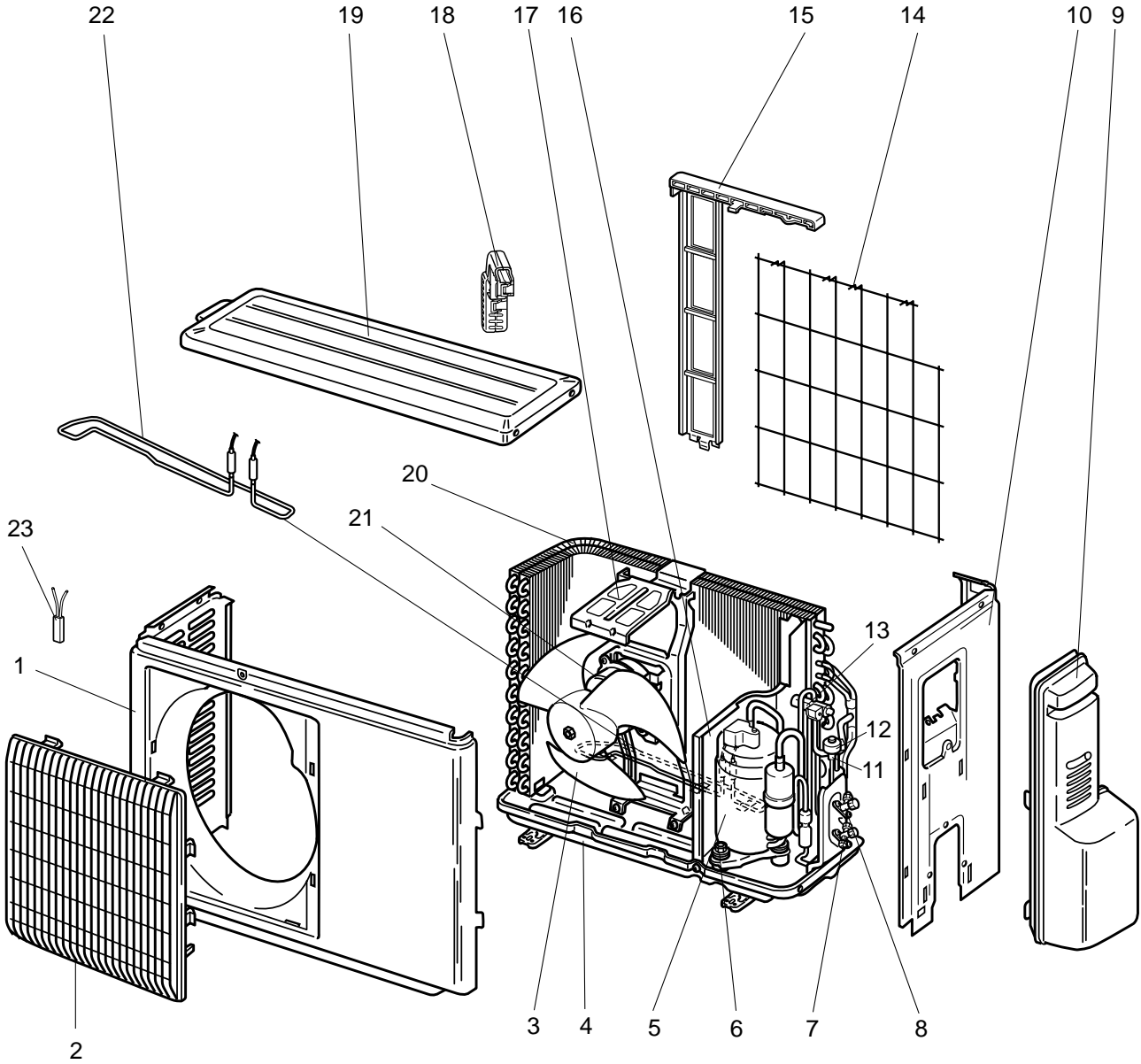

1-1. OUTDOOR UNIT STRUCTURAL PARTS AND FUNCTIONAL PARTS

Part number that is circled is not shown in the illustration.

No.	RoHS	Part No.	Part Name	Symbol in Wiring Diagram	Q'ty/unit		Remarks
					MUZ-FD25VABH- E1	MUZ-FD35VABH- E1	
1	G	E12 927 232	CABINET		1	1	
2	G	E12 927 521	GRILLE		1	1	
3	G	E12 927 501	PROPELLER		1	1	
4	G	E12 928 290	BASE		1	1	
5	G	E12 C37 900	COMPRESSOR	MC	1	1	SNB130FGBH
6	G	E12 C34 506	COMPRESSOR RUBBER SET		3	3	3 RUBBERS/SET
7	G	E12 927 661	STOP VALVE (GAS)		1	1	ø9.52
8	G	E12 927 662	STOP VALVE (LIQUID)		1	1	ø6.35
9	G	E12 927 245	SERVICE PANEL		1	1	
10	G	E12 C37 233	BACK PANEL		1	1	
11	G	E12 838 640	EXPANSION VALVE		1	1	
12	G	E12 927 493	EXPANSION VALVE COIL	LEV	1	1	
13	G	E12 D65 961	4-WAY VALVE		1	1	
14	G	E12 930 525	CONDENSER WIRE NET		1	1	
15	G	E12 930 523	CONDENSER NET		1	1	
16	G	E12 C36 293	SEPARATOR		1	1	
17	G	E12 929 515	MOTOR SUPPORT		1	1	
18	G	E12 D84 079	THERMO HOLDER		1	1	
19	G	E12 927 297	TOP PANEL		1	1	
20	G	E12 C34 630	OUTDOOR HEAT EXCHANGER		1	1	
21	G	E12 C34 301	OUTDOOR FAN MOTOR	MF	1	1	RC0J50-□□
22	G	E12 C36 526	DEFROST HEATER	H	1	1	
23	G	E12 C36 381	HEATER PROTECTOR	26H	1	1	
24	G	E12 927 937	CAPILLARY TUBE		1	1	ø3.0×ø2.0×240
25	G	E12 735 936	CAPILLARY TUBE		2	2	ø3.0×ø1.8×600



MUZ-FD25VABH MUZ-FD35VABH
1-2. OUTDOOR UNIT ELECTRICAL PARTS

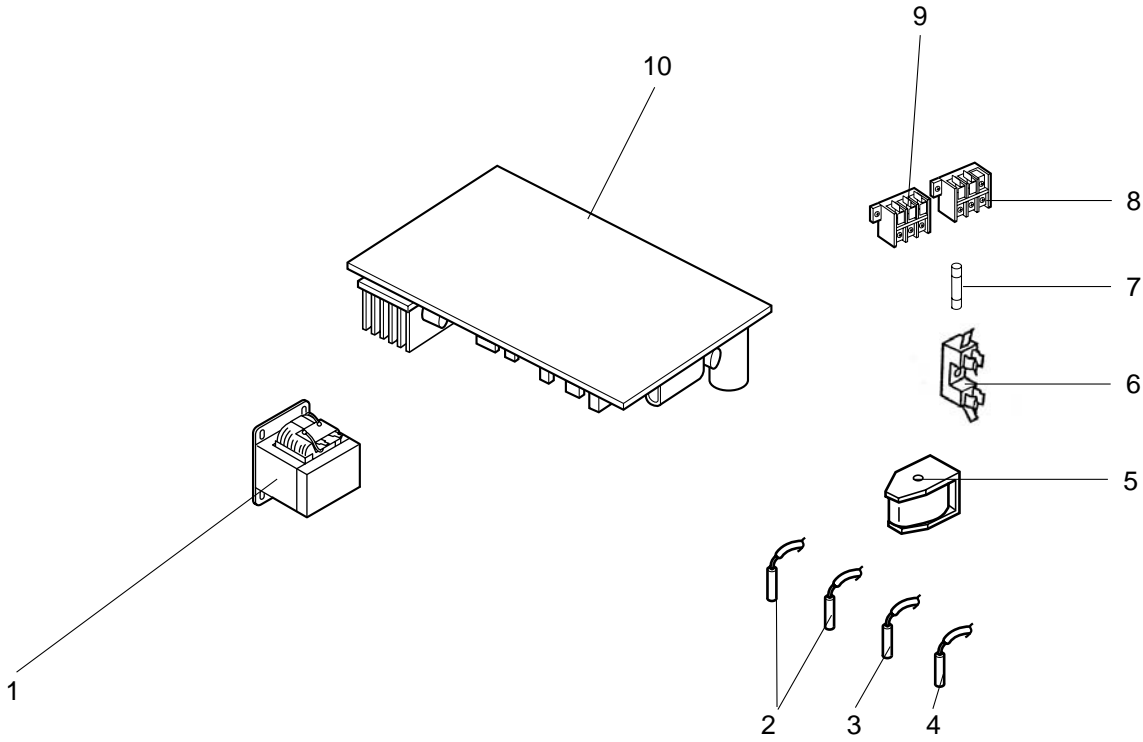

1-2. OUTDOOR UNIT ELECTRICAL PARTS

Part number that is circled is not shown in the illustration.

No.	RoHS	Part No.	Part Name	Symbol in Wiring Diagram	Q'ty/unit		Remarks
					MUZ-FD25VABH- E1	MUZ-FD35VABH- E1	
1	G	E12 838 337	REACTOR	L61	1	1	
2	G	E12 C34 306	THERMISTOR SET	RT61, RT62	1	1	DEFROST, DISCHARGE
3	G	E12 D65 308	AMBIENT TEMPERATURE THER- MISTOR	RT65	1	1	
4	G	E12 C34 307	OUTDOOR HEAT EXCHANGER TEMPERATURE THERMISTOR	RT68	1	1	
5	G	E12 C34 490	R.V. COIL	21S4	1	1	
6	G	E12 735 241	FUSE HOLDER		1	1	
7	G	E12 735 382	FUSE	F61	1	1	T20AL250V
8	G	E12 573 375	TERMINAL BLOCK	TB1	1	1	3 P
9	G	E12 927 374	TERMINAL BLOCK	TB2	1	1	3 P
10	G	E12 D65 451	INVERTER P.C. BOARD		1		Including heat sink and RT64
	G	E12 D66 451				1	
⑪	G	E12 784 382	FUSE	F701, F801, F901	1	1	T3.15AL250V
⑫	G	E12 661 385	VARISTOR	NR61-NR64	1	1	

MUZ-FD50VABH

1-3. OUTDOOR UNIT STRUCTURAL PARTS, ELECTRICAL PARTS AND FUNCTIONAL PARTS

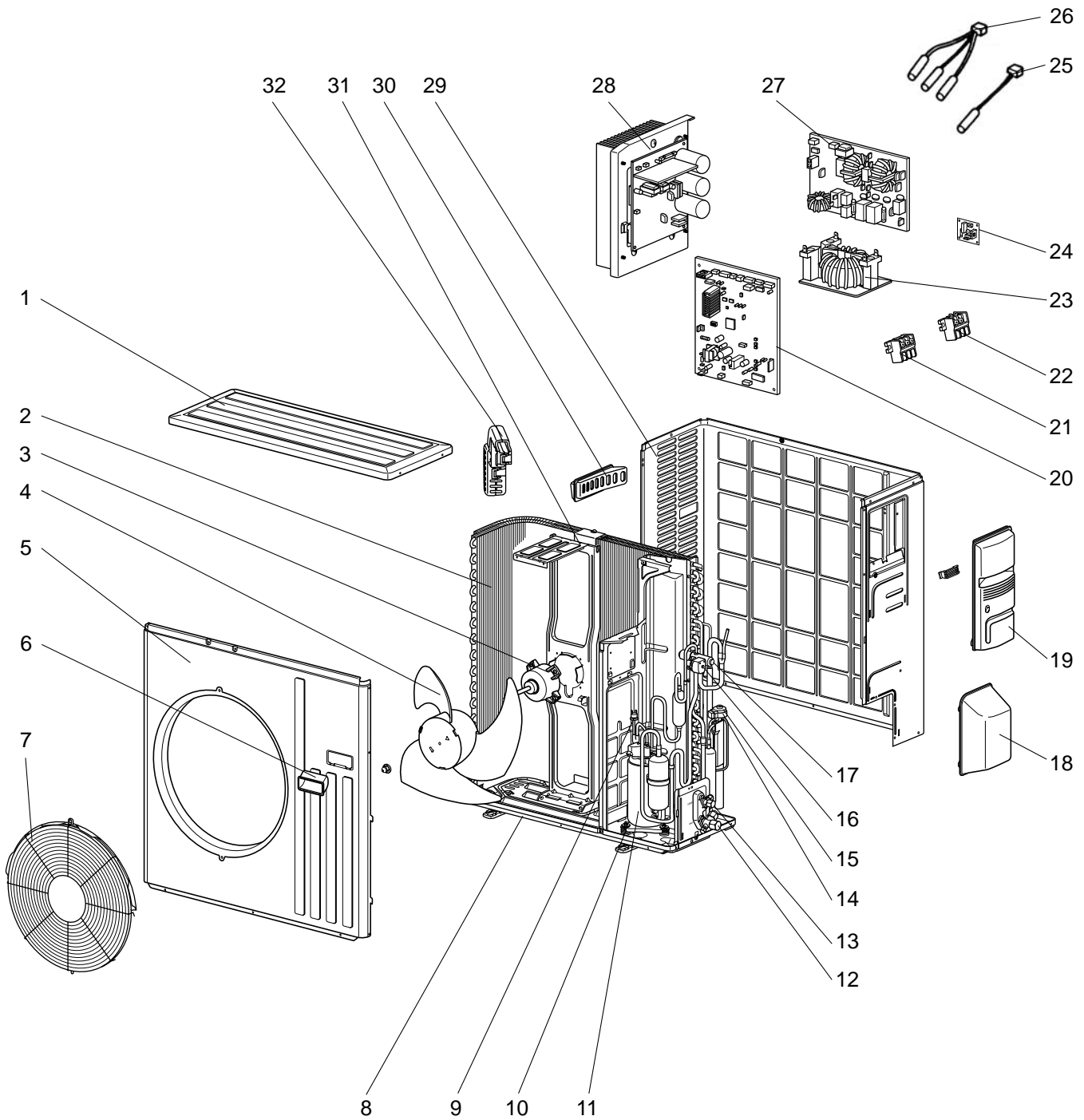

1-3. OUTDOOR UNIT STRUCTURAL PARTS, ELECTRICAL PARTS AND FUNCTIONAL PARTS

Part number that is circled is not shown in the illustration.

No.	RCHS	Part No.	Part Name	Symbol in Wiring Diagram	Q'ty/unit	Remarks
					MUZ-FD50VABH- [E1]	
1	G	E12 819 297	TOP PANEL		1	
2	G	E12 D84 630	OUTDOOR HEAT EXCHANGER		1	
3	G	E12 938 301	OUTDOOR FAN MOTOR	MF	1	RC0J60-□□
4	G	E12 851 501	PROPELLER		1	
5	G	E12 819 232	CABINET		1	
6	G	E12 819 009	HANDLE		1	
7	G	E12 D84 521	FAN GUARD		1	Including ice guard
8	G	E12 D84 290	BASE		1	
9	G	E12 853 646	HIGH PRESSURE SWITCH	HPS	1	
10	G	E12 C34 506	COMPRESSOR RUBBER SET		3	3 RUBBERS/SET
11	G	E12 D84 900	COMPRESSOR	MC	1	SNB172FDGH
12	G	E12 851 661	STOP VALVE (GAS)		1	∅12.7
13	G	E12 B36 662	STOP VALVE (LIQUID)		1	∅6.35
14	G	E12 851 640	EXPANSION VALVE		1	
15	G	E12 851 493	EXPANSION VALVE COIL	LEV	1	
16	G	E12 935 490	R.V. COIL	21S4	1	
17	G	E12 891 961	4-WAY VALVE		1	
18	G	E12 819 650	VALVE COVER		1	
19	G	E12 819 245	SERVICE PANEL		1	
20	G	E12 D84 450	OUTDOOR ELECTRONIC CONTROL P.C. BOARD		1	
21	G	E12 935 374	TERMINAL BLOCK	TB1	1	3 P
22	G	E12 817 374	TERMINAL BLOCK	TB2	1	3 P
23	G	E12 851 337	REACTOR	L	1	
24	G	E12 D84 445	RELAY P.C. BOARD		1	
25	G	E12 D84 309	AMBIENT TEMPERATURE THERMISTOR	RT65	1	
26	G	E12 D84 308	THERMISTOR SET	RT61,RT62, RT68	1	DEFROST, DISCHARGE, OUTDOOR HEAT EXCHANGER
27	G	E12 D84 444	NOISE FILTER P.C. BOARD		1	
28	G	E12 D84 440	POWER BOARD		1	Including heat sink and RT64
29	G	E12 D84 233	BACK PANEL (OUT)		1	
30	G	E12 817 009	HANDLE		1	
31	G	E12 D84 515	MOTOR SUPPORT		1	
32	G	E12 D84 079	THERMO HOLDER		1	
(33)	G	E12 784 382	FUSE	F71,F801	1	T3.15AL250V
(34)	G	E12 977 385	FUSE & VARISTOR SET	F64,NR64	1	T2AL250V
(35)	G	E12 853 936	CAPILLARY TUBE (TAPER PIPE)		1	∅3.6 x ∅2.4 x 50
(36)	G	E12 D84 381	HEATER PROTECTOR	26H	1	
(37)	G	E12 D84 526	DEFROST HEATER	H	1	

※ Please confirm the serial number when exchanging parts.



© Copyright 2008 MITSUBISHI ELECTRIC ENGINEERING CO.,LTD
Distributed in Jun. 2010. No. OBB519 REVISED EDITION-A 5
Distributed in Jul. 2008. No. OBB519 6
Made in Japan

New publication, effective Jun. 2010
Specifications subject to change without notice.