

Revision A:

- MUZ-FD25VAH-**E2** has been added.

Please void OBH489.

OUTDOOR UNIT SERVICE MANUAL



No. OBH489
REVISED EDITION-A

Wireless type Models

- MUZ-FD25VA** - **E1**
- MUZ-FD25VAH** - **E1**
- MUZ-FD25VAH** - **E2**
- MUZ-FD35VA** - **E1**
- MUZ-FD35VAH** - **E1**

Indoor unit service manual
MSZ-FD•VA Series (OBH488)

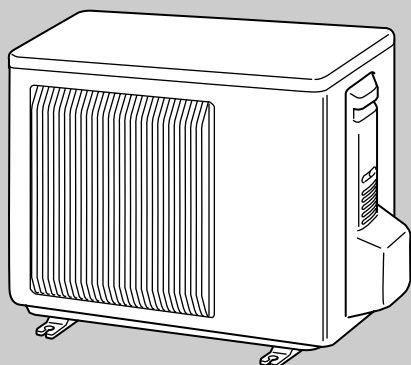

CONTENTS

1. TECHNICAL CHANGES	3
2. PART NAMES AND FUNCTIONS.....	3
3. SPECIFICATION.....	4
4. NOISE CRITERIA CURVES	6
5. OUTLINES AND DIMENSIONS	7
6. WIRING DIAGRAM	8
7. REFRIGERANT SYSTEM DIAGRAM	10
8. PERFORMANCE CURVES	11
9. ACTUATOR CONTROL.....	22
10. SERVICE FUNCTIONS.....	23
11. TROUBLESHOOTING	23
12. DISASSEMBLY INSTRUCTIONS.....	39

PARTS CATALOG (OBB489)

NOTE:

RoHS compliant products have <G> mark on the spec name plate.



Revision A:

- MUZ-FD25VAH- has been added.
- Power outlet has been corrected.

1

TECHNICAL CHANGES

MUZ-FD25VA -^[E1]

MUZ-FD25VAH -^[E1]

MUZ-FD35VA -^[E1]

MUZ-FD35VAH -^[E1]

1.New model

MUZ-FD25VAH -^[E1] → MUZ-FD25VAH -^[E2]

1.Power outlet ^[E1] : 12 A, ^[E2] : 10 A

2

PART NAMES AND FUNCTIONS

MUZ-FD25VA
MUZ-FD25VAH
MUZ-FD35VA
MUZ-FD35VAH

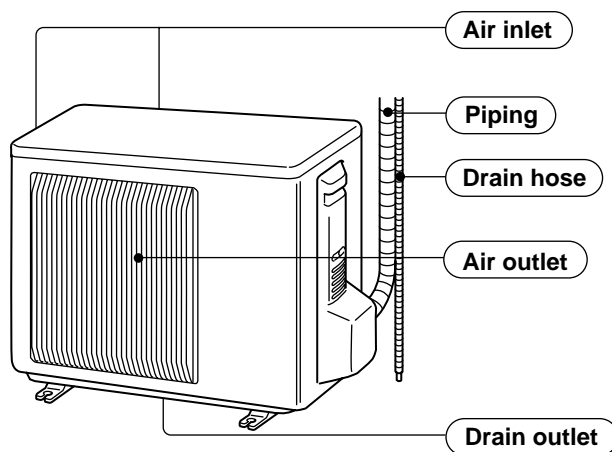

ACCESSORIES

		MUZ-FD25/35VA
①	Drain socket	1

3

SPECIFICATION

Outdoor model			MUZ-FD25VA	MUZ-FD25VAH	MUZ-FD35VA	MUZ-FD35VAH		
Power supply			Single phase 230 V, 50 Hz					
Capacity Rated frequency(Min.-Max.)		Cooling Heating	kW		2.5 (1.1-3.5)	3.5 (1.1-4.0)	3.5(0.8-4.0)	
			3.2 (1.5-5.5)	3.2 (1.5-6.3)	4.0 (1.5-6.3)	4.0 (1.3-7.7)		
Electrical data	Power outlet		A	10	E1:12 E2:10	10	12	
	Power input *1(Total)	Cooling	W	485		850	835	
		Heating	W	610		865	850	
	Running current *1(Total)	Cooling	A	2.4		3.9	3.8	
		Heating	A	2.9		4.0	3.9	
	Power factor *1(Total)	Cooling	%	88		95	96	
Heating		%	91		94	95		
Starting current *1(Total)		A	2.9		4.0	3.9		
Coefficient of performance(C.O.P) *1(Total)		Cooling	5.15		4.12	4.19		
		Heating	5.25		4.62	4.71		
Compressor	Model		SNB130FGBH					
	Output		W	900				
	Current *1	Cooling	A	1.88		3.31	3.21	
Heating		A	2.30		3.33	3.23		
Fan motor	Model		RC0J50-EA					
	Current *1	Cooling	A	0.27		0.32		
		Heating	A	0.30		0.35		
Dimensions W×H×D			mm	800×550×285				
Weight			kg	36				
Special remarks	Dehumidification		Cooling	ℓ /h		1.4		2.0
	Air flow *1 (High/Low) (High/Med./Low)	Cooling	m ³ /h	1,872/1,086		1,872/1,086		
		Heating		2,016/1,776/1,386				
	Sound level *1	Cooling	dB(A)	46		47		
		Heating				50		
	Fan speed (High/Low) (High/Med./Low)	Cooling	rpm	810/490		810/490		
		Heating		870/770/610				
	Fan speed regulator			3				
Refrigerant filling capacity(R410A)			kg				1.15	
Refrigeration oil (Model)			NEO22					

NOTE : Test conditions are based on ISO 5151

Cooling : Indoor Dry-bulb temperature 27 °C

Outdoor Dry-bulb temperature 35 °C

Heating : Indoor Dry-bulb temperature 20 °C

Outdoor Dry-bulb temperature 7 °C

Refrigerant piping length (one way): 5 m

*1 Measured under rated operating frequency

Wet-bulb temperature 19 °C

Wet-bulb temperature 6 °C

Specifications and rating conditions of main electric parts

Item \ Model		MUZ-FD25VA	MUZ-FD25VAH	MUZ-FD35VA	MUZ-FD35VAH
Current transformer	(CT)	20 A			
	(CT761, CT781)	15 A			
Smoothing capacitor	(C61, C62, C63)	620 μ F 420 V			
Diode module	(DB61)	15 A 600 V			
	(DB65)	25 A 600 V			
Fuse	(F61)	T20AL250V			
	(F701,F801,F901)	T3.15AL250V			
Defrost heater	(H)	—	230 V 130 W	—	230 V 130 W
Intelligent power module	(IPM)	20 A 600 V			
Expansion valve coil	(LEV)	DC 12 V			
Reactor	(L61)	23.0 mH			
Current-detecting resistor	(R61,R62)	180 m Ω 5 W (2 elements)			
	(R825)	25 m Ω 5 W			
	(R937,R938,R939)	430 m Ω 2 W			
Current-limiting PTC thermistor	(PTC64,PTC65)	33 Ω			
Terminal block	(TB1,TB2)	3P			
Relay	(X63)	3 A 250 V			
	(X64)	20 A 250 V			
	(X66)	—	3 A 250 V	—	3 A 250 V
R.V.coil	(21S4)	AC 220 - 240 V			
Heater protector	(26H)	—	Open 45 $^{\circ}$ C	—	Open 45 $^{\circ}$ C
IGBT	(TR821)	30 A 600 V			

NOISE CRITERIA CURVES

MUZ-FD25VA MUZ-FD25VAH

FUNCTION	SPL(dB(A))	LINE
COOLING	46	●—●
HEATING		○—○

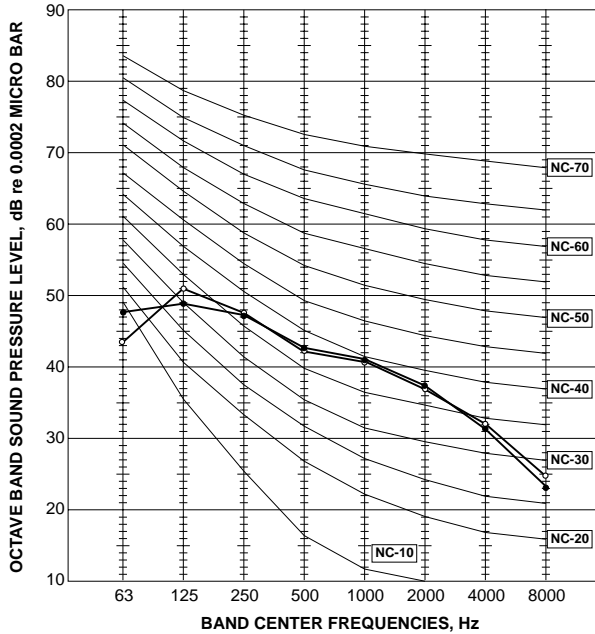

MUZ-FD35VA MUZ-FD35VAH

FUNCTION	SPL(dB(A))	LINE
COOLING	47	●—●
HEATING	50	○—○

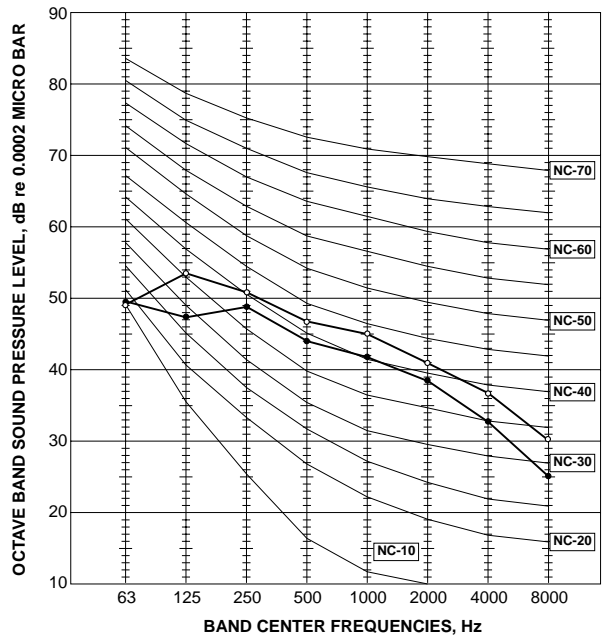

Test conditions

Cooling : Dry-bulb temperature 35 °C

Heating : Dry-bulb temperature 7 °C Wet-bulb temperature 6 °C

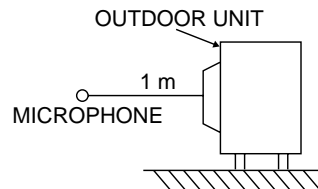

5

OUTLINES AND DIMENSIONS

MUZ-FD25VA
MUZ-FD25VAH
MUZ-FD35VA
MUZ-FD35VAH

Unit: mm

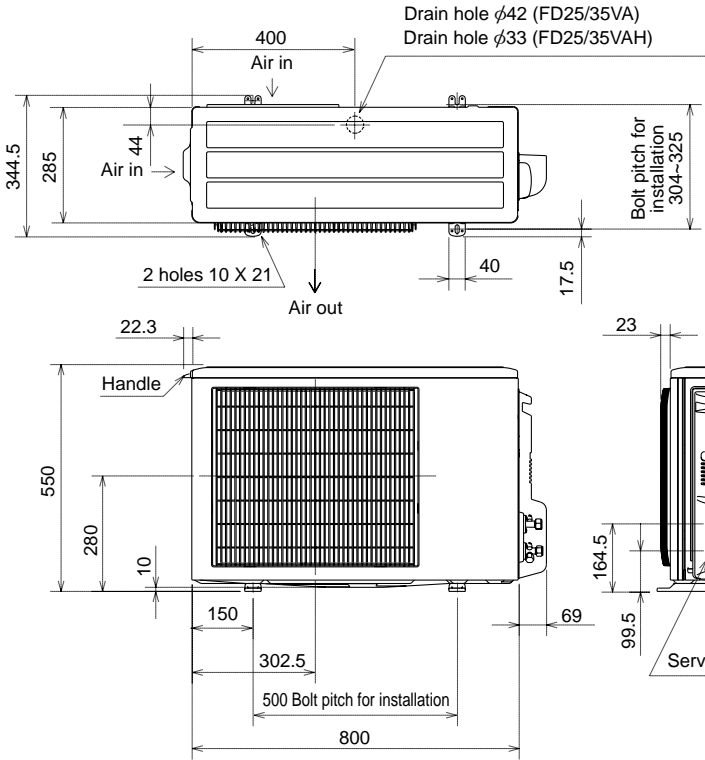

REQUIRED SPACE

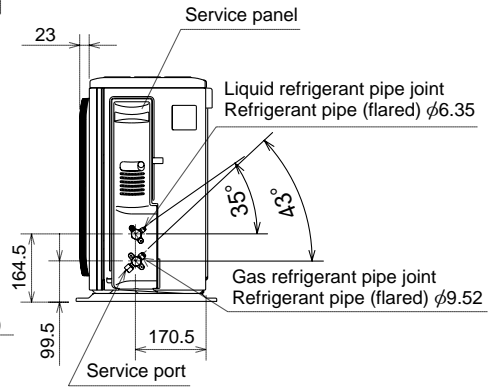
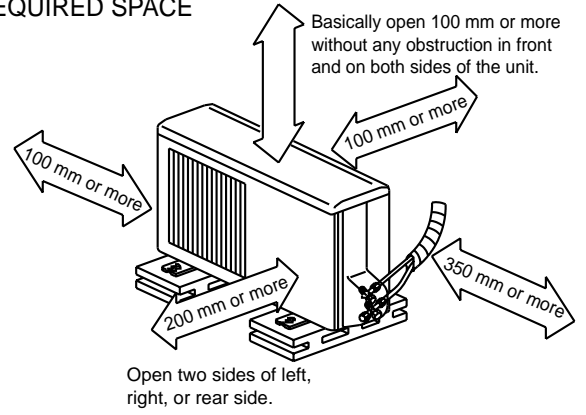

MUZ-FD25VAH
 MUZ-FD35VAH

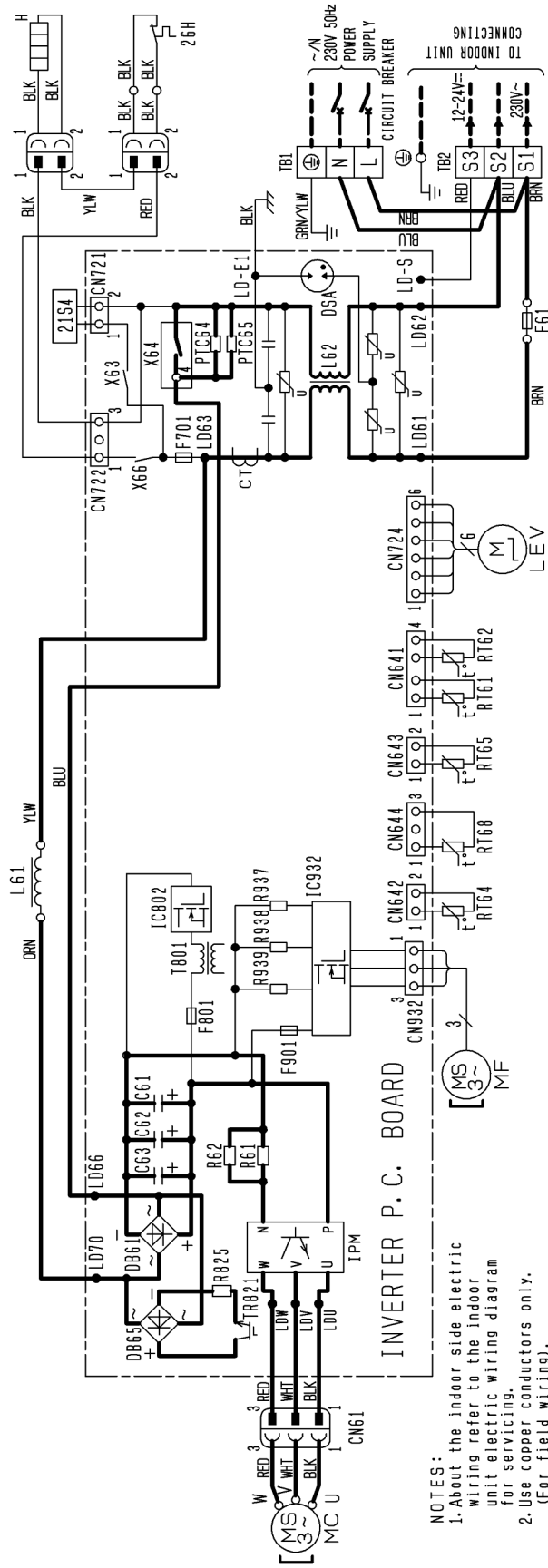

- NOTES:
- About the indoor side electric wiring refer to the indoor unit electric wiring diagram for servicing.
 - Use copper conductors only. (For field wiring).

SYMBOL	NAME	SYMBOL	NAME
CT	CURRENT TRANSFORMER	R61, R62	CURRENT-DETECTING RESISTOR
L61, L62, C63	SMOOTHING CAPACITOR	R625, R937	CURRENT-DETECTING RESISTOR
DB61, DB65	DIODE MODULE	R938, R939	CURRENT-DETECTING RESISTOR
DSA	SURGE ABSORBER	TB1, TB2	TERMINAL BLOCK
F61	FUSE (T20A, 250V)	TR821	SWITCHING POWER TRANSISTOR
F101, F601, F901	FUSE (T3.15A, 250V)	T801	TRANSFORMER
IC802	INTELLIGENT POWER DEVICE	X63, X64, X66	REVERSING VALVE COIL
IPM, IC932	INTELLIGENT POWER MODULE	H	DEFROST HEATER
L61	REACTOR	21S4	OUTDOOR HEAT EXCHANGER
L62	CMC COIL	26H	HEATER PROTECTOR

**MUZ-FD25VA
MUZ-FD25VAH
MUZ-FD35VA
MUZ-FD35VAH**

Unit:mm

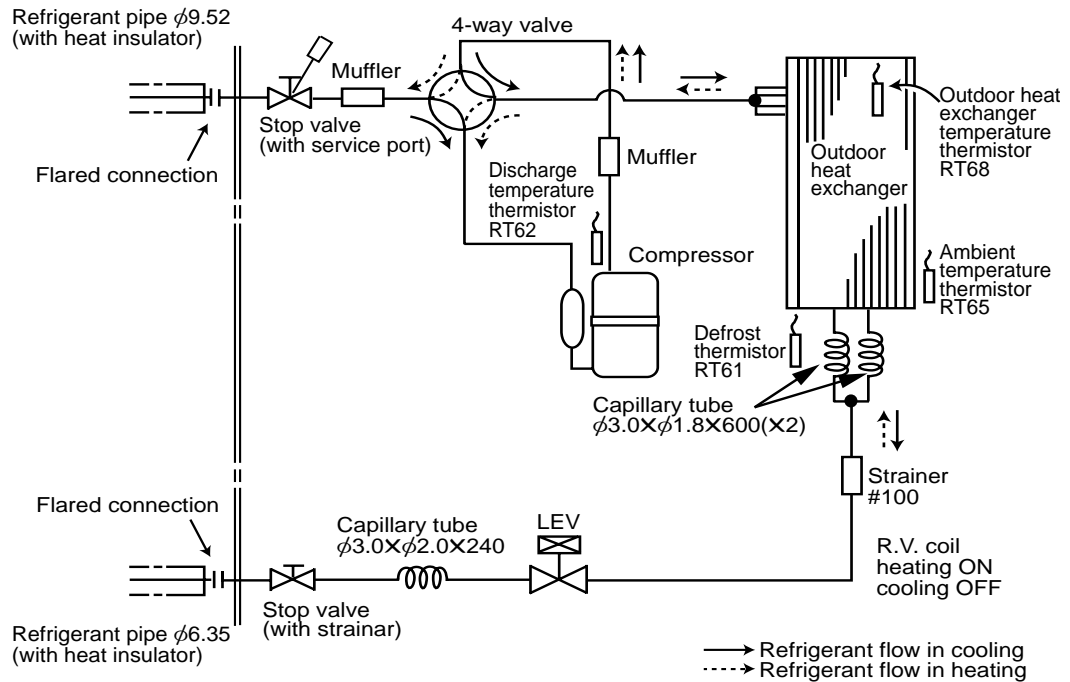

MAX. REFRIGERANT PIPING LENGTH and MAX. HEIGHT DIFFERENCE

Model	Refrigerant piping : m		Piping size O.D : mm	
	Max. length	Max. Height difference	Gas	Liquid
	A	B		
MUZ-FD25VA MUZ-FD25VAH MUZ-FD35VA MUZ-FD35VAH	20	12	9.52	6.35

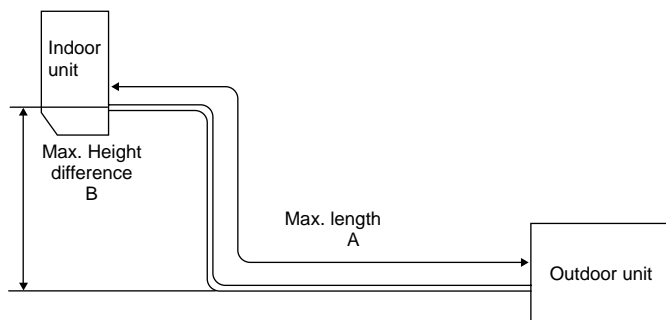

ADDITIONAL REFRIGERANT CHARGE (R410A:g)

Model	Outdoor unit precharged	Refrigerant piping length (one way)											
		5m	6m	7m	8m	9m	10m	11m	12m	13m	14m	15m	20m
MUZ-FD25VA MUZ-FD25VAH MUZ-FD35VA MUZ-FD35VAH	1,150	0	0	0	90	120	150	180	210	240	270	300	450

Calculation : $X_g = 30 \text{ g/m} \times (\text{Refrigerant piping length (m)} - 7)$

NOTE: Refrigerant piping exceeding 7 m requires additional refrigerant charge according to the calculation.

MUZ-FD25VA MUZ-FD35VA
MUZ-FD25VAH MUZ-FD35VAH

The standard specifications apply only to the operation of the air conditioner under normal conditions. Since operating conditions vary according to the areas where these units are installed, the following information has been provided to clarify the operating characteristics of the air conditioner under the conditions indicated by the performance curve.

(1) GUARANTEED VOLTAGE

198 ~ 264 V, 50 Hz

(2) AIR FLOW

Air flow should be set at MAX.

(3) MAIN READINGS

- | | | |
|---|-------|-----------|
| (1) Indoor intake air wet-bulb temperature : | °C WB | } Cooling |
| (2) Indoor outlet air wet-bulb temperature : | °C WB | |
| (3) Outdoor intake air dry-bulb temperature : | °C DB | |
| (4) Total input: | W | } Heating |
| (5) Indoor intake air dry-bulb temperature : | °C DB | |
| (6) Outdoor intake air wet-bulb temperature : | °C WB | |
| (7) Total input : | W | |

Indoor air wet/dry-bulb temperature difference on the left side of the following chart shows the difference between the indoor intake air wet/dry-bulb temperature and the indoor outlet air wet/dry-bulb temperature for your reference at service.

How to measure the indoor air wet-bulb / dry-bulb temperature difference

1. Attach at least 2 sets of wet and dry-bulb thermometers to the indoor air intake as shown in the figure, and at least 2 sets of wet and dry-bulb thermometers to the indoor air outlet. The thermometers must be attached to the position where air speed is high.
2. Attach at least 2 sets of wet and dry-bulb thermometers to the outdoor air intake. Cover the thermometers to prevent direct rays of the sun.
3. Check that the air filter is cleaned.
4. Open windows and doors of room.
5. Press the EMERGENCY OPERATION switch once (twice) to start the EMERGENCY COOL (HEAT) MODE.
6. When system stabilizes after more than 15 minutes, measure temperature and take an average temperature.
7. 10 minutes later, measure temperature again and check that the temperature does not change.

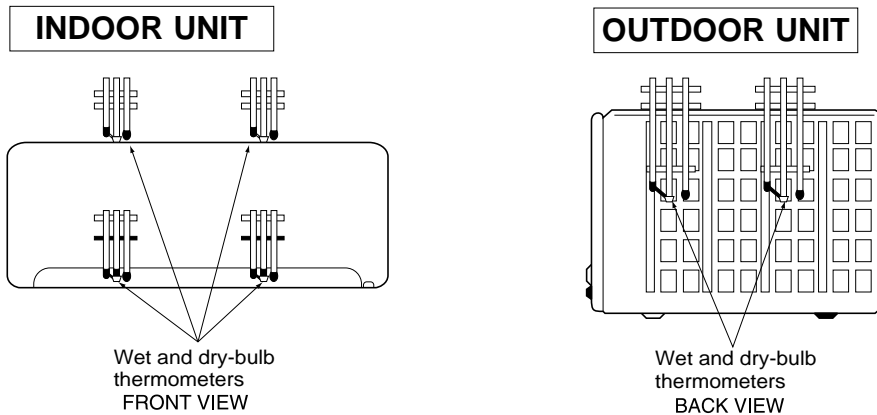

8-1. Capacity and input curves

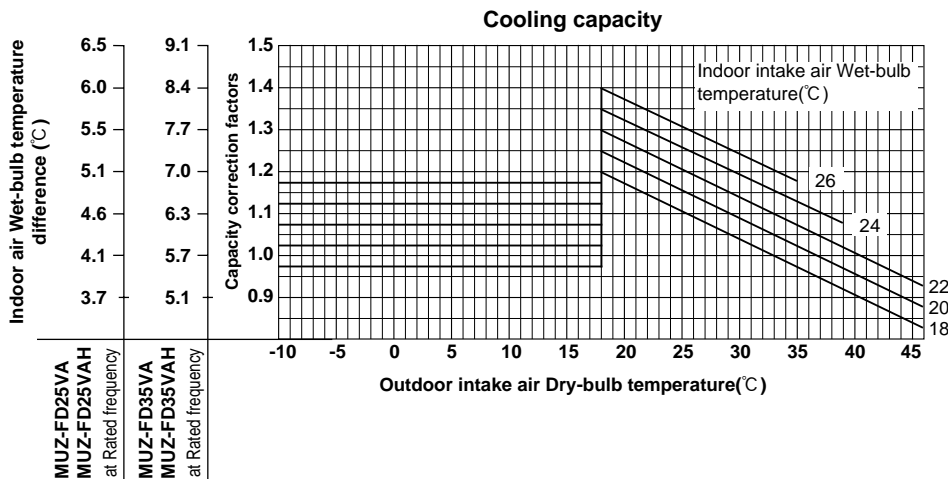

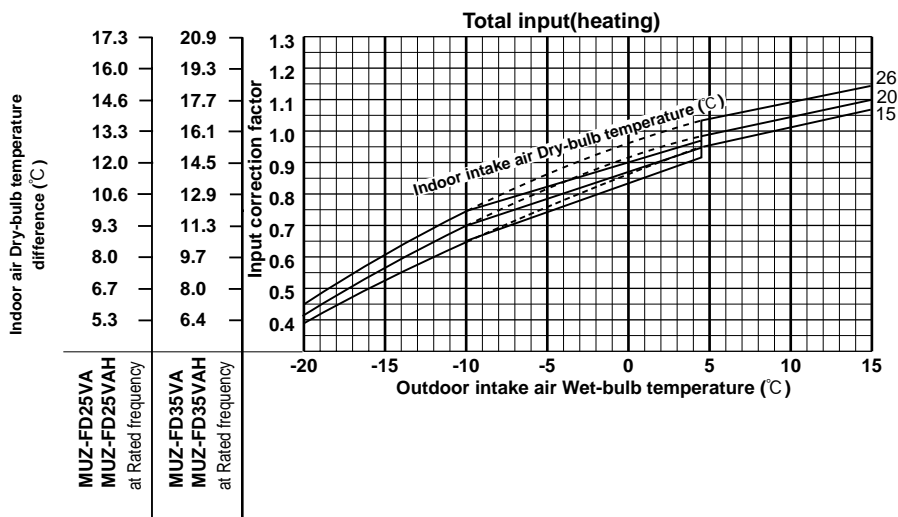
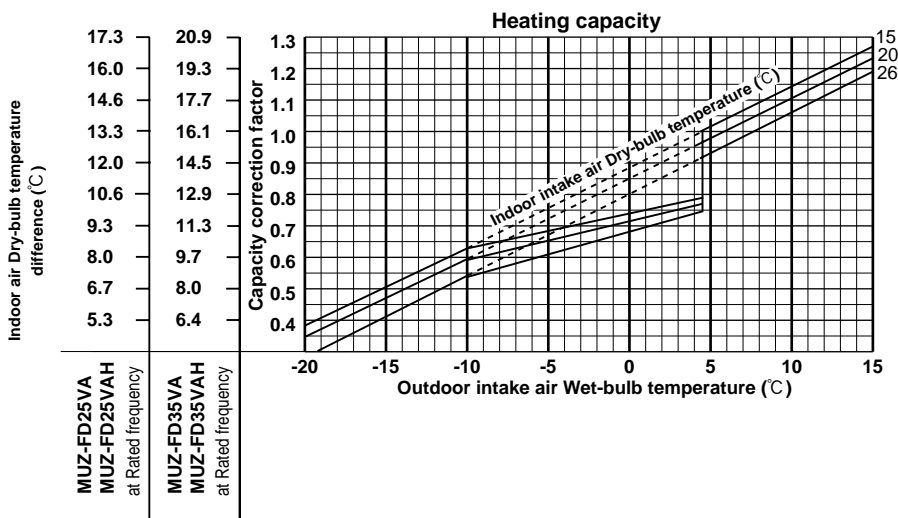
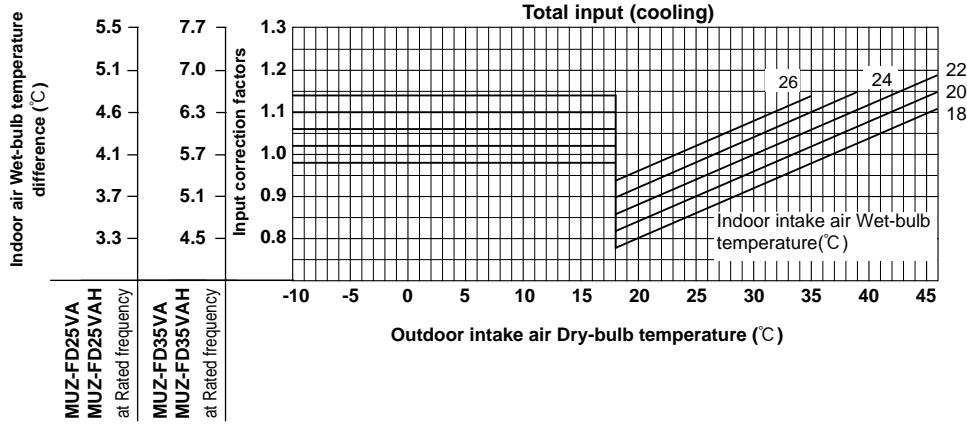

NOTE:The above broken lines are for the heating operation without any frost and defrost operation.

8-2. Capacity and input correction by operational frequency of compressor

MUZ-FD25VA MUZ-FD25VAH

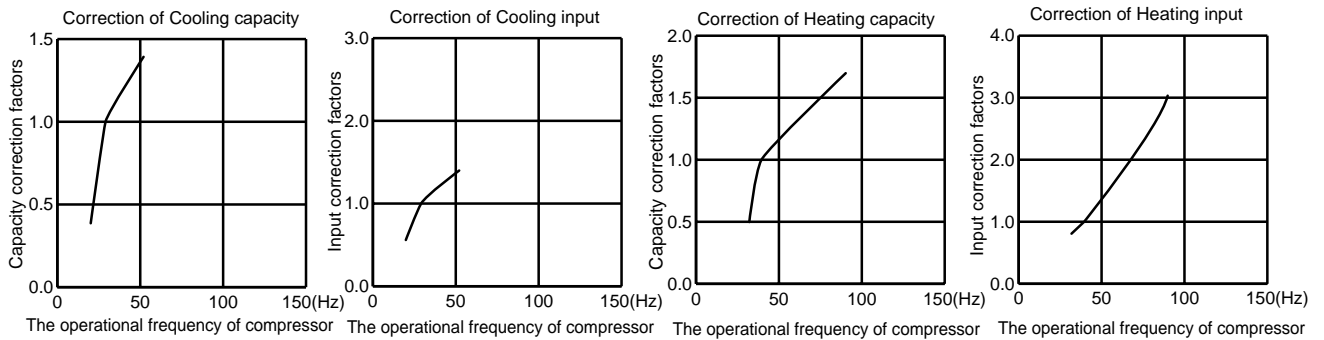

MUZ-FD35VA

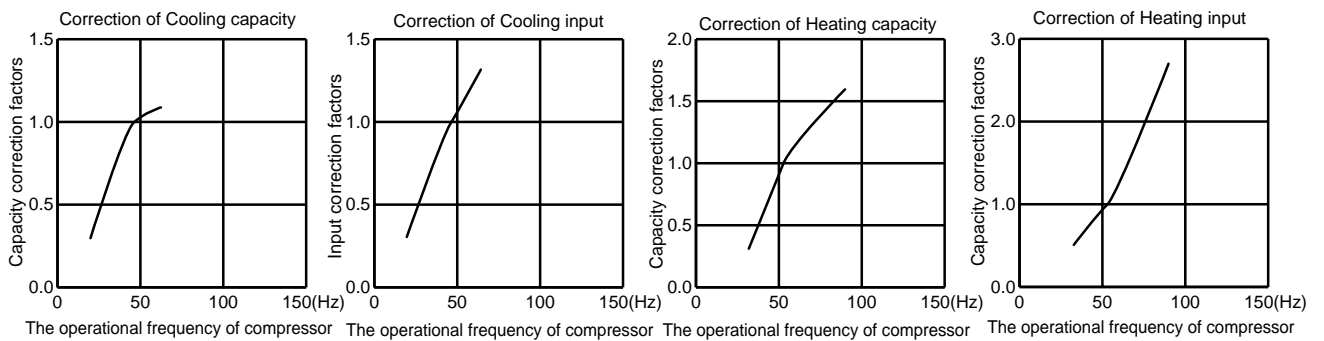

MUZ-FD35VAH

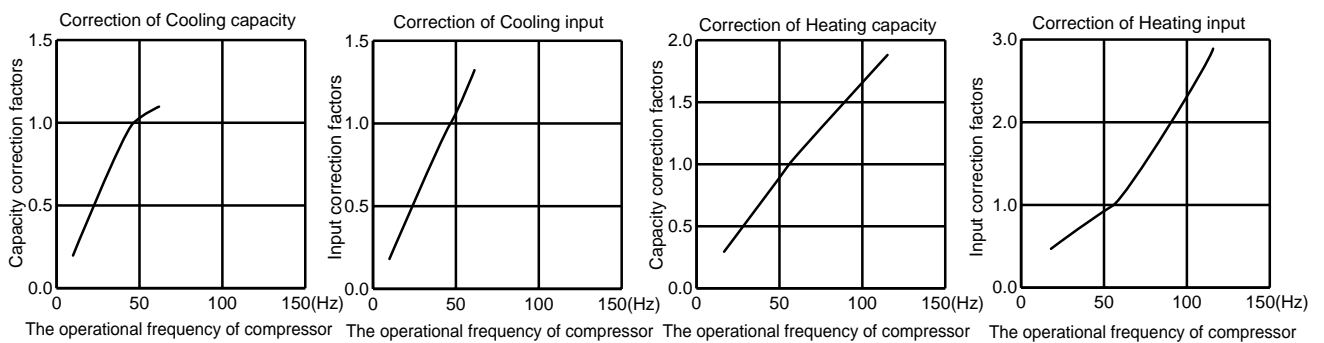

8-3. Test run operation (How to operate fixed-frequency operation)

1. Press EMERGENCY OPERATION switch to COOL or HEAT mode (COOL : Press once, HEAT : Press twice).
2. Test run operation starts and continues to operate for 30 minutes.
3. Compressor operates at rated frequency in COOL mode or 58Hz in HEAT mode.
4. Indoor fan operates at High speed.
5. After 30 minutes, test run operation finishes and EMERGENCY OPERATION starts (Operation frequency of compressor varies).
6. To cancel test run operation (EMERGENCY OPERATION), press EMERGENCY OPERATION switch or any button on remote controller.

8-4. Outdoor low pressure and outdoor unit current

COOL operation

- ① Both indoor and outdoor unit are under the same temperature/humidity condition.
- ② Operation : TEST RUN OPERATION (refer to 8-3.)

Dry-bulb temperature(°C)	Relative humidity(%)
20	50
25	60
30	70

Outdoor low pressure

MUZ-FD25VA MUZ-FD25VAH

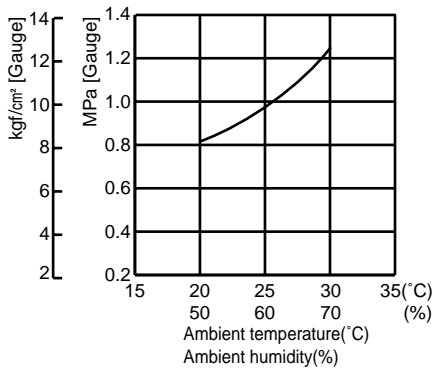

MUZ-FD35VA

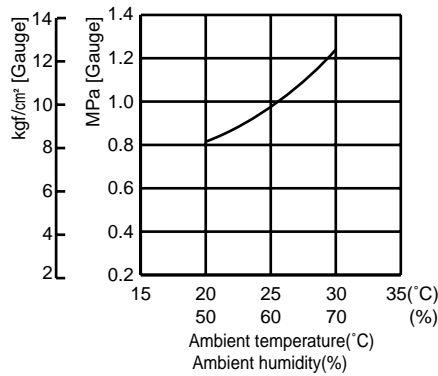

MUZ-FD35VAH

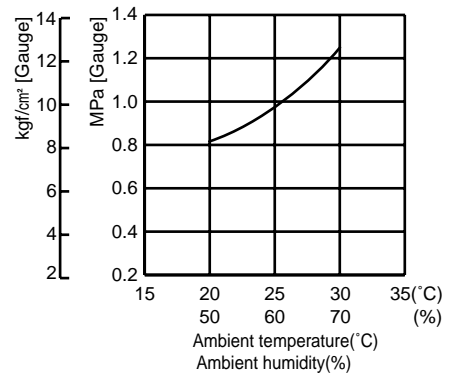

NOTE :

The unit of pressure has been changed to MPa on the international system of units (SI unit system)
 The conversion factor is: **1(MPa [Gauge]) =10.2(kgf/cm² [Gauge])**

Outdoor unit current

MUZ-FD25VA MUZ-FD25VAH

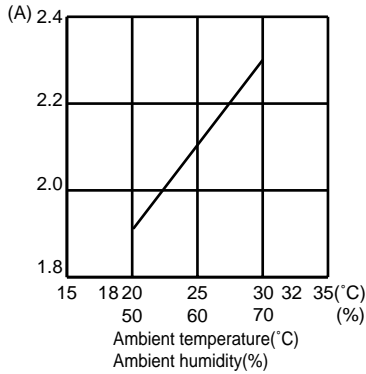

MUZ-FD35VA

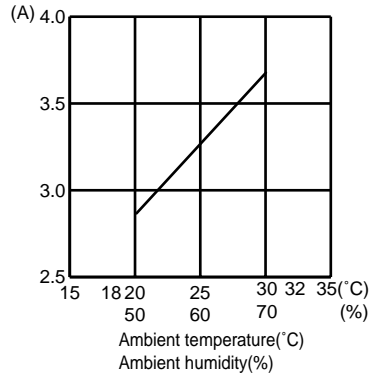

MUZ-FD35VAH

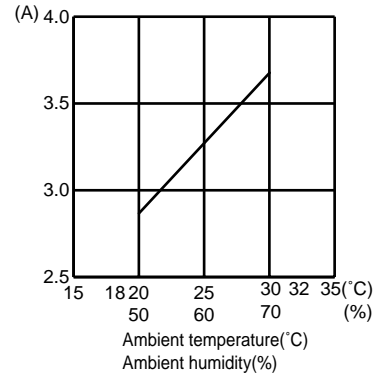

HEAT operation

① Condition :

	Indoor	Outdoor			
Dry bulb temperature (°C)	20.0	2	7	15	20.0
Wet bulb temperature (°C)	14.5	1	6	12	14.5

- ② Operation : Test run operation (refer to 8-3.)

Outdoor unit current

MUZ-FD25VA MUZ-FD25VAH

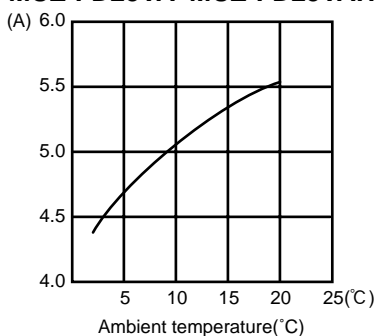

MUZ-FD35VA

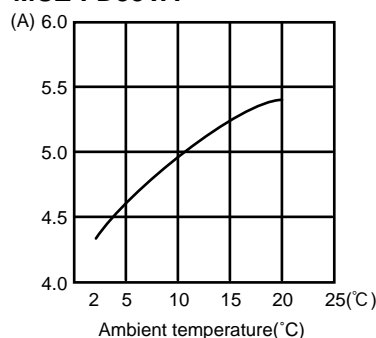

MUZ-FD35VAH

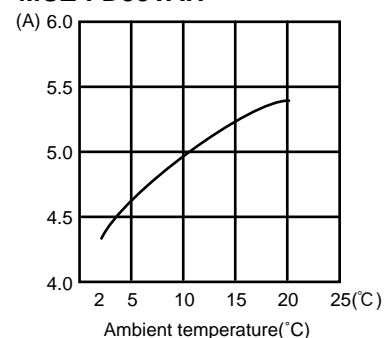

PERFORMANCE DATA COOL operation at Rated frequency

MUZ-FD25VA MUZ-FD25VAH

CAPACITY:2.5(kW) SHF:0.85 INPUT:485(W)

		OUTDOOR DB(°C)															
INDOOR DB(°C)	INDOOR WB(°C)	21				25				27				30			
		Q	SHC	SHF	INPUT	Q	SHC	SHF	INPUT	Q	SHC	SHF	INPUT	Q	SHC	SHF	INPUT
21	18	2.94	1.97	0.67	388	2.81	1.88	0.67	407	2.70	1.81	0.67	427	2.60	1.74	0.67	446
21	20	3.06	1.68	0.55	407	2.94	1.62	0.55	432	2.85	1.57	0.55	441	2.75	1.51	0.55	461
22	18	2.94	2.09	0.71	388	2.81	2.00	0.71	407	2.70	1.92	0.71	427	2.60	1.85	0.71	446
22	20	3.06	1.81	0.59	407	2.94	1.73	0.59	432	2.85	1.68	0.59	441	2.75	1.62	0.59	461
22	22	3.19	1.50	0.47	422	3.08	1.45	0.47	449	3.00	1.41	0.47	461	2.88	1.35	0.47	480
23	18	2.94	2.20	0.75	388	2.81	2.11	0.75	407	2.70	2.03	0.75	427	2.60	1.95	0.75	446
23	20	3.06	1.93	0.63	407	2.94	1.85	0.63	432	2.85	1.80	0.63	441	2.75	1.73	0.63	461
23	22	3.19	1.63	0.51	422	3.08	1.57	0.51	449	3.00	1.53	0.51	461	2.88	1.47	0.51	480
24	18	2.94	2.32	0.79	388	2.81	2.22	0.79	407	2.70	2.13	0.79	427	2.60	2.05	0.79	446
24	20	3.06	2.05	0.67	407	2.94	1.97	0.67	432	2.85	1.91	0.67	441	2.75	1.84	0.67	461
24	22	3.19	1.75	0.55	422	3.08	1.69	0.55	449	3.00	1.65	0.55	461	2.88	1.58	0.55	480
24	24	3.35	1.44	0.43	441	3.23	1.39	0.43	466	3.15	1.35	0.43	480	3.05	1.31	0.43	504
25	18	2.94	2.44	0.83	388	2.81	2.33	0.83	407	2.70	2.24	0.83	427	2.60	2.16	0.83	446
25	20	3.06	2.17	0.71	407	2.94	2.09	0.71	432	2.85	2.02	0.71	441	2.75	1.95	0.71	461
25	22	3.19	1.88	0.59	422	3.08	1.81	0.59	449	3.00	1.77	0.59	461	2.88	1.70	0.59	480
25	24	3.35	1.57	0.47	441	3.23	1.52	0.47	466	3.15	1.48	0.47	480	3.05	1.43	0.47	504
26	18	2.94	2.56	0.87	388	2.81	2.45	0.87	407	2.70	2.35	0.87	427	2.60	2.26	0.87	446
26	20	3.06	2.30	0.75	407	2.94	2.20	0.75	432	2.85	2.14	0.75	441	2.75	2.06	0.75	461
26	22	3.19	2.01	0.63	422	3.08	1.94	0.63	449	3.00	1.89	0.63	461	2.88	1.81	0.63	480
26	24	3.35	1.71	0.51	441	3.23	1.64	0.51	466	3.15	1.61	0.51	480	3.05	1.56	0.51	504
26	26	3.45	1.35	0.39	466	3.35	1.31	0.39	490	3.30	1.29	0.39	504	3.20	1.25	0.39	519
27	18	2.94	2.67	0.91	388	2.81	2.56	0.91	407	2.70	2.46	0.91	427	2.60	2.37	0.91	446
27	20	3.06	2.42	0.79	407	2.94	2.32	0.79	432	2.85	2.25	0.79	441	2.75	2.17	0.79	461
27	22	3.19	2.14	0.67	422	3.08	2.06	0.67	449	3.00	2.01	0.67	461	2.88	1.93	0.67	480
27	24	3.35	1.84	0.55	441	3.23	1.77	0.55	466	3.15	1.73	0.55	480	3.05	1.68	0.55	504
27	26	3.45	1.48	0.43	466	3.35	1.44	0.43	490	3.30	1.42	0.43	504	3.20	1.38	0.43	519
28	18	2.94	2.79	0.95	388	2.81	2.67	0.95	407	2.70	2.57	0.95	427	2.60	2.47	0.95	446
28	20	3.06	2.54	0.83	407	2.94	2.44	0.83	432	2.85	2.37	0.83	441	2.75	2.28	0.83	461
28	22	3.19	2.26	0.71	422	3.08	2.18	0.71	449	3.00	2.13	0.71	461	2.88	2.04	0.71	480
28	24	3.35	1.98	0.59	441	3.23	1.90	0.59	466	3.15	1.86	0.59	480	3.05	1.80	0.59	504
28	26	3.45	1.62	0.47	466	3.35	1.57	0.47	490	3.30	1.55	0.47	504	3.20	1.50	0.47	519
29	18	2.94	2.91	0.99	388	2.81	2.78	0.99	407	2.70	2.67	0.99	427	2.60	2.57	0.99	446
29	20	3.06	2.66	0.87	407	2.94	2.56	0.87	432	2.85	2.48	0.87	441	2.75	2.39	0.87	461
29	22	3.19	2.39	0.75	422	3.08	2.31	0.75	449	3.00	2.25	0.75	461	2.88	2.16	0.75	480
29	24	3.35	2.11	0.63	441	3.23	2.03	0.63	466	3.15	1.98	0.63	480	3.05	1.92	0.63	504
29	26	3.45	1.76	0.51	466	3.35	1.71	0.51	490	3.30	1.68	0.51	504	3.20	1.63	0.51	519
30	18	2.94	2.94	1.00	388	2.81	2.81	1.00	407	2.70	2.70	1.00	427	2.60	2.60	1.00	446
30	20	3.06	2.79	0.91	407	2.94	2.67	0.91	432	2.85	2.59	0.91	441	2.75	2.50	0.91	461
30	22	3.19	2.52	0.79	422	3.08	2.43	0.79	449	3.00	2.37	0.79	461	2.88	2.27	0.79	480
30	24	3.35	2.24	0.67	441	3.23	2.16	0.67	466	3.15	2.11	0.67	480	3.05	2.04	0.67	504
30	26	3.45	1.90	0.55	466	3.35	1.84	0.55	490	3.30	1.82	0.55	504	3.20	1.76	0.55	519
31	18	2.94	2.94	1.00	388	2.81	2.81	1.00	407	2.70	2.70	1.00	427	2.60	2.60	1.00	446
31	20	3.06	2.91	0.95	407	2.94	2.79	0.95	432	2.85	2.71	0.95	441	2.75	2.61	0.95	461
31	22	3.19	2.65	0.83	422	3.08	2.55	0.83	449	3.00	2.49	0.83	461	2.88	2.39	0.83	480
31	24	3.35	2.38	0.71	441	3.23	2.29	0.71	466	3.15	2.24	0.71	480	3.05	2.17	0.71	504
31	26	3.45	2.04	0.59	466	3.35	1.98	0.59	490	3.30	1.95	0.59	504	3.20	1.89	0.59	519
32	18	2.94	2.94	1.00	388	2.81	2.81	1.00	407	2.70	2.70	1.00	427	2.60	2.60	1.00	446
32	20	3.06	3.03	0.99	407	2.94	2.91	0.99	432	2.85	2.82	0.99	441	2.75	2.72	0.99	461
32	22	3.19	2.77	0.87	422	3.08	2.68	0.87	449	3.00	2.61	0.87	461	2.88	2.50	0.87	480
32	24	3.35	2.51	0.75	441	3.23	2.42	0.75	466	3.15	2.36	0.75	480	3.05	2.29	0.75	504
32	26	3.45	2.17	0.63	466	3.35	2.11	0.63	490	3.30	2.08	0.63	504	3.20	2.02	0.63	519

NOTE: Q : Total capacity (kW) SHF : Sensible heat factor DB : Dry-bulb temperature
 SHC : Sensible heat capacity (kW) INPUT : Total power input (W) WB : Wet-bulb temperature

PERFORMANCE DATA COOL operation at Rated frequency

MUZ-FD25VA MUZ-FD25VAH

CAPACITY:2.5(kW) SHF:0.85 INPUT:485(W)

		OUTDOOR DB(°C)											
INDOOR DB (°C)	INDOOR WB (°C)	35				40				46			
		Q	SHC	SHF	INPUT	Q	SHC	SHF	INPUT	Q	SHC	SHF	INPUT
21	18	2.45	1.64	0.67	475	2.25	1.51	0.67	504	2.08	1.39	0.67	524
21	20	2.58	1.42	0.55	495	2.40	1.32	0.55	519	2.23	1.22	0.55	548
22	18	2.45	1.74	0.71	475	2.25	1.60	0.71	504	2.08	1.47	0.71	524
22	20	2.58	1.52	0.59	495	2.40	1.42	0.59	519	2.23	1.31	0.59	548
22	22	2.73	1.28	0.47	514	2.55	1.20	0.47	543	2.38	1.12	0.47	563
23	18	2.45	1.84	0.75	475	2.25	1.69	0.75	504	2.08	1.56	0.75	524
23	20	2.58	1.62	0.63	495	2.40	1.51	0.63	519	2.23	1.40	0.63	548
23	22	2.73	1.39	0.51	514	2.55	1.30	0.51	543	2.38	1.21	0.51	563
24	18	2.45	1.94	0.79	475	2.25	1.78	0.79	504	2.08	1.64	0.79	524
24	20	2.58	1.73	0.67	495	2.40	1.61	0.67	519	2.23	1.49	0.67	548
24	22	2.73	1.50	0.55	514	2.55	1.40	0.55	543	2.38	1.31	0.55	563
24	24	2.88	1.24	0.43	534	2.70	1.16	0.43	558	2.55	1.10	0.43	582
25	18	2.45	2.03	0.83	475	2.25	1.87	0.83	504	2.08	1.72	0.83	524
25	20	2.58	1.83	0.71	495	2.40	1.70	0.71	519	2.23	1.58	0.71	548
25	22	2.73	1.61	0.59	514	2.55	1.50	0.59	543	2.38	1.40	0.59	563
25	24	2.88	1.35	0.47	534	2.70	1.27	0.47	558	2.55	1.20	0.47	582
26	18	2.45	2.13	0.87	475	2.25	1.96	0.87	504	2.08	1.81	0.87	524
26	20	2.58	1.93	0.75	495	2.40	1.80	0.75	519	2.23	1.67	0.75	548
26	22	2.73	1.72	0.63	514	2.55	1.61	0.63	543	2.38	1.50	0.63	563
26	24	2.88	1.47	0.51	534	2.70	1.38	0.51	558	2.55	1.30	0.51	582
26	26	3.03	1.18	0.39	553	2.85	1.11	0.39	577	2.68	1.04	0.39	601
27	18	2.45	2.23	0.91	475	2.25	2.05	0.91	504	2.08	1.89	0.91	524
27	20	2.58	2.03	0.79	495	2.40	1.90	0.79	519	2.23	1.76	0.79	548
27	22	2.73	1.83	0.67	514	2.55	1.71	0.67	543	2.38	1.59	0.67	563
27	24	2.88	1.58	0.55	534	2.70	1.49	0.55	558	2.55	1.40	0.55	582
27	26	3.03	1.30	0.43	553	2.85	1.23	0.43	577	2.68	1.15	0.43	601
28	18	2.45	2.33	0.95	475	2.25	2.14	0.95	504	2.08	1.97	0.95	524
28	20	2.58	2.14	0.83	495	2.40	1.99	0.83	519	2.23	1.85	0.83	548
28	22	2.73	1.93	0.71	514	2.55	1.81	0.71	543	2.38	1.69	0.71	563
28	24	2.88	1.70	0.59	534	2.70	1.59	0.59	558	2.55	1.50	0.59	582
28	26	3.03	1.42	0.47	553	2.85	1.34	0.47	577	2.68	1.26	0.47	601
29	18	2.45	2.43	0.99	475	2.25	2.23	0.99	504	2.08	2.05	0.99	524
29	20	2.58	2.24	0.87	495	2.40	2.09	0.87	519	2.23	1.94	0.87	548
29	22	2.73	2.04	0.75	514	2.55	1.91	0.75	543	2.38	1.78	0.75	563
29	24	2.88	1.81	0.63	534	2.70	1.70	0.63	558	2.55	1.61	0.63	582
29	26	3.03	1.54	0.51	553	2.85	1.45	0.51	577	2.68	1.36	0.51	601
30	18	2.45	2.45	1.00	475	2.25	2.25	1.00	504	2.08	2.08	1.00	524
30	20	2.58	2.34	0.91	495	2.40	2.18	0.91	519	2.23	2.02	0.91	548
30	22	2.73	2.15	0.79	514	2.55	2.01	0.79	543	2.38	1.88	0.79	563
30	24	2.88	1.93	0.67	534	2.70	1.81	0.67	558	2.55	1.71	0.67	582
30	26	3.03	1.66	0.55	553	2.85	1.57	0.55	577	2.68	1.47	0.55	601
31	18	2.45	2.45	1.00	475	2.25	2.25	1.00	504	2.08	2.08	1.00	524
31	20	2.58	2.45	0.95	495	2.40	2.28	0.95	519	2.23	2.11	0.95	548
31	22	2.73	2.26	0.83	514	2.55	2.12	0.83	543	2.38	1.97	0.83	563
31	24	2.88	2.04	0.71	534	2.70	1.92	0.71	558	2.55	1.81	0.71	582
31	26	3.03	1.78	0.59	553	2.85	1.68	0.59	577	2.68	1.58	0.59	601
32	18	2.45	2.45	1.00	475	2.25	2.25	1.00	504	2.08	2.08	1.00	524
32	20	2.58	2.55	0.99	495	2.40	2.38	0.99	519	2.23	2.20	0.99	548
32	22	2.73	2.37	0.87	514	2.55	2.22	0.87	543	2.38	2.07	0.87	563
32	24	2.88	2.16	0.75	534	2.70	2.03	0.75	558	2.55	1.91	0.75	582
32	26	3.03	1.91	0.63	553	2.85	1.80	0.63	577	2.68	1.69	0.63	601

NOTE: Q : Total capacity (kW) SHF : Sensible heat factor DB : Dry-bulb temperature
 SHC : Sensible heat capacity (kW) INPUT : Total power input (W) WB : Wet-bulb temperature

PERFORMANCE DATA COOL operation at Rated frequency
MUZ-FD35VA

CAPACITY:3.5(kW) SHF:0.85 INPUT:850(W)

		OUTDOOR DB(°C)															
INDOOR DB(°C)	INDOOR WB(°C)	21				25				27				30			
		Q	SHC	SHF	INPUT	Q	SHC	SHF	INPUT	Q	SHC	SHF	INPUT	Q	SHC	SHF	INPUT
21	18	4.11	2.76	0.67	680	3.94	2.64	0.67	714	3.78	2.53	0.67	748	3.64	2.44	0.67	782
21	20	4.29	2.36	0.55	714	4.11	2.26	0.55	757	3.99	2.19	0.55	774	3.85	2.12	0.55	808
22	18	4.11	2.92	0.71	680	3.94	2.80	0.71	714	3.78	2.68	0.71	748	3.64	2.58	0.71	782
22	20	4.29	2.53	0.59	714	4.11	2.43	0.59	757	3.99	2.35	0.59	774	3.85	2.27	0.59	808
22	22	4.46	2.10	0.47	740	4.31	2.02	0.47	786	4.20	1.97	0.47	808	4.03	1.89	0.47	842
23	18	4.11	3.08	0.75	680	3.94	2.95	0.75	714	3.78	2.84	0.75	748	3.64	2.73	0.75	782
23	20	4.29	2.70	0.63	714	4.11	2.59	0.63	757	3.99	2.51	0.63	774	3.85	2.43	0.63	808
23	22	4.46	2.28	0.51	740	4.31	2.20	0.51	786	4.20	2.14	0.51	808	4.03	2.05	0.51	842
24	18	4.11	3.25	0.79	680	3.94	3.11	0.79	714	3.78	2.99	0.79	748	3.64	2.88	0.79	782
24	20	4.29	2.87	0.67	714	4.11	2.76	0.67	757	3.99	2.67	0.67	774	3.85	2.58	0.67	808
24	22	4.46	2.45	0.55	740	4.31	2.37	0.55	786	4.20	2.31	0.55	808	4.03	2.21	0.55	842
24	24	4.69	2.02	0.43	774	4.52	1.94	0.43	816	4.41	1.90	0.43	842	4.27	1.84	0.43	884
25	18	4.11	3.41	0.83	680	3.94	3.27	0.83	714	3.78	3.14	0.83	748	3.64	3.02	0.83	782
25	20	4.29	3.04	0.71	714	4.11	2.92	0.71	757	3.99	2.83	0.71	774	3.85	2.73	0.71	808
25	22	4.46	2.63	0.59	740	4.31	2.54	0.59	786	4.20	2.48	0.59	808	4.03	2.37	0.59	842
25	24	4.69	2.20	0.47	774	4.52	2.12	0.47	816	4.41	2.07	0.47	842	4.27	2.01	0.47	884
26	18	4.11	3.58	0.87	680	3.94	3.43	0.87	714	3.78	3.29	0.87	748	3.64	3.17	0.87	782
26	20	4.29	3.22	0.75	714	4.11	3.08	0.75	757	3.99	2.99	0.75	774	3.85	2.89	0.75	808
26	22	4.46	2.81	0.63	740	4.31	2.71	0.63	786	4.20	2.65	0.63	808	4.03	2.54	0.63	842
26	24	4.69	2.39	0.51	774	4.52	2.30	0.51	816	4.41	2.25	0.51	842	4.27	2.18	0.51	884
26	26	4.83	1.88	0.39	816	4.69	1.83	0.39	859	4.62	1.80	0.39	884	4.48	1.75	0.39	910
27	18	4.11	3.74	0.91	680	3.94	3.58	0.91	714	3.78	3.44	0.91	748	3.64	3.31	0.91	782
27	20	4.29	3.39	0.79	714	4.11	3.25	0.79	757	3.99	3.15	0.79	774	3.85	3.04	0.79	808
27	22	4.46	2.99	0.67	740	4.31	2.88	0.67	786	4.20	2.81	0.67	808	4.03	2.70	0.67	842
27	24	4.69	2.58	0.55	774	4.52	2.48	0.55	816	4.41	2.43	0.55	842	4.27	2.35	0.55	884
27	26	4.83	2.08	0.43	816	4.69	2.02	0.43	859	4.62	1.99	0.43	884	4.48	1.93	0.43	910
28	18	4.11	3.91	0.95	680	3.94	3.74	0.95	714	3.78	3.59	0.95	748	3.64	3.46	0.95	782
28	20	4.29	3.56	0.83	714	4.11	3.41	0.83	757	3.99	3.31	0.83	774	3.85	3.20	0.83	808
28	22	4.46	3.17	0.71	740	4.31	3.06	0.71	786	4.20	2.98	0.71	808	4.03	2.86	0.71	842
28	24	4.69	2.77	0.59	774	4.52	2.66	0.59	816	4.41	2.60	0.59	842	4.27	2.52	0.59	884
28	26	4.83	2.27	0.47	816	4.69	2.20	0.47	859	4.62	2.17	0.47	884	4.48	2.11	0.47	910
29	18	4.11	4.07	0.99	680	3.94	3.90	0.99	714	3.78	3.74	0.99	748	3.64	3.60	0.99	782
29	20	4.29	3.73	0.87	714	4.11	3.58	0.87	757	3.99	3.47	0.87	774	3.85	3.35	0.87	808
29	22	4.46	3.35	0.75	740	4.31	3.23	0.75	786	4.20	3.15	0.75	808	4.03	3.02	0.75	842
29	24	4.69	2.95	0.63	774	4.52	2.84	0.63	816	4.41	2.78	0.63	842	4.27	2.69	0.63	884
29	26	4.83	2.46	0.51	816	4.69	2.39	0.51	859	4.62	2.36	0.51	884	4.48	2.28	0.51	910
30	18	4.11	4.11	1.00	680	3.94	3.94	1.00	714	3.78	3.78	1.00	748	3.64	3.64	1.00	782
30	20	4.29	3.90	0.91	714	4.11	3.74	0.91	757	3.99	3.63	0.91	774	3.85	3.50	0.91	808
30	22	4.46	3.53	0.79	740	4.31	3.40	0.79	786	4.20	3.32	0.79	808	4.03	3.18	0.79	842
30	24	4.69	3.14	0.67	774	4.52	3.03	0.67	816	4.41	2.95	0.67	842	4.27	2.86	0.67	884
30	26	4.83	2.66	0.55	816	4.69	2.58	0.55	859	4.62	2.54	0.55	884	4.48	2.46	0.55	910
31	18	4.11	4.11	1.00	680	3.94	3.94	1.00	714	3.78	3.78	1.00	748	3.64	3.64	1.00	782
31	20	4.29	4.07	0.95	714	4.11	3.91	0.95	757	3.99	3.79	0.95	774	3.85	3.66	0.95	808
31	22	4.46	3.70	0.83	740	4.31	3.57	0.83	786	4.20	3.49	0.83	808	4.03	3.34	0.83	842
31	24	4.69	3.33	0.71	774	4.52	3.21	0.71	816	4.41	3.13	0.71	842	4.27	3.03	0.71	884
31	26	4.83	2.85	0.59	816	4.69	2.77	0.59	859	4.62	2.73	0.59	884	4.48	2.64	0.59	910
32	18	4.11	4.11	1.00	680	3.94	3.94	1.00	714	3.78	3.78	1.00	748	3.64	3.64	1.00	782
32	20	4.29	4.24	0.99	714	4.11	4.07	0.99	757	3.99	3.95	0.99	774	3.85	3.81	0.99	808
32	22	4.46	3.88	0.87	740	4.31	3.75	0.87	786	4.20	3.65	0.87	808	4.03	3.50	0.87	842
32	24	4.69	3.52	0.75	774	4.52	3.39	0.75	816	4.41	3.31	0.75	842	4.27	3.20	0.75	884
32	26	4.83	3.04	0.63	816	4.69	2.95	0.63	859	4.62	2.91	0.63	884	4.48	2.82	0.63	910

NOTE: Q : Total capacity (kW) SHF : Sensible heat factor DB : Dry-bulb temperature
 SHC : Sensible heat capacity (kW) INPUT : Total power input (W) WB : Wet-bulb temperature

PERFORMANCE DATA COOL operation at Rated frequency
MUZ-FD35VA

CAPACITY:3.5(kW) SHF:0.85 INPUT:850(W)

		OUTDOOR DB(°C)											
INDOOR DB (°C)	INDOOR WB (°C)	35				40				46			
		Q	SHC	SHF	INPUT	Q	SHC	SHF	INPUT	Q	SHC	SHF	INPUT
21	18	3.43	2.30	0.67	833	3.15	2.11	0.67	884	2.91	1.95	0.67	918
21	20	3.61	1.98	0.55	867	3.36	1.85	0.55	910	3.12	1.71	0.55	961
22	18	3.43	2.44	0.71	833	3.15	2.24	0.71	884	2.91	2.06	0.71	918
22	20	3.61	2.13	0.59	867	3.36	1.98	0.59	910	3.12	1.84	0.59	961
22	22	3.82	1.79	0.47	901	3.57	1.68	0.47	952	3.33	1.56	0.47	986
23	18	3.43	2.57	0.75	833	3.15	2.36	0.75	884	2.91	2.18	0.75	918
23	20	3.61	2.27	0.63	867	3.36	2.12	0.63	910	3.12	1.96	0.63	961
23	22	3.82	1.95	0.51	901	3.57	1.82	0.51	952	3.33	1.70	0.51	986
24	18	3.43	2.71	0.79	833	3.15	2.49	0.79	884	2.91	2.29	0.79	918
24	20	3.61	2.42	0.67	867	3.36	2.25	0.67	910	3.12	2.09	0.67	961
24	22	3.82	2.10	0.55	901	3.57	1.96	0.55	952	3.33	1.83	0.55	986
24	24	4.03	1.73	0.43	935	3.78	1.63	0.43	978	3.57	1.54	0.43	1020
25	18	3.43	2.85	0.83	833	3.15	2.61	0.83	884	2.91	2.41	0.83	918
25	20	3.61	2.56	0.71	867	3.36	2.39	0.71	910	3.12	2.21	0.71	961
25	22	3.82	2.25	0.59	901	3.57	2.11	0.59	952	3.33	1.96	0.59	986
25	24	4.03	1.89	0.47	935	3.78	1.78	0.47	978	3.57	1.68	0.47	1020
26	18	3.43	2.98	0.87	833	3.15	2.74	0.87	884	2.91	2.53	0.87	918
26	20	3.61	2.70	0.75	867	3.36	2.52	0.75	910	3.12	2.34	0.75	961
26	22	3.82	2.40	0.63	901	3.57	2.25	0.63	952	3.33	2.09	0.63	986
26	24	4.03	2.05	0.51	935	3.78	1.93	0.51	978	3.57	1.82	0.51	1020
26	26	4.24	1.65	0.39	969	3.99	1.56	0.39	1012	3.75	1.46	0.39	1054
27	18	3.43	3.12	0.91	833	3.15	2.87	0.91	884	2.91	2.64	0.91	918
27	20	3.61	2.85	0.79	867	3.36	2.65	0.79	910	3.12	2.46	0.79	961
27	22	3.82	2.56	0.67	901	3.57	2.39	0.67	952	3.33	2.23	0.67	986
27	24	4.03	2.21	0.55	935	3.78	2.08	0.55	978	3.57	1.96	0.55	1020
27	26	4.24	1.82	0.43	969	3.99	1.72	0.43	1012	3.75	1.61	0.43	1054
28	18	3.43	3.26	0.95	833	3.15	2.99	0.95	884	2.91	2.76	0.95	918
28	20	3.61	2.99	0.83	867	3.36	2.79	0.83	910	3.12	2.59	0.83	961
28	22	3.82	2.71	0.71	901	3.57	2.53	0.71	952	3.33	2.36	0.71	986
28	24	4.03	2.37	0.59	935	3.78	2.23	0.59	978	3.57	2.11	0.59	1020
28	26	4.24	1.99	0.47	969	3.99	1.88	0.47	1012	3.75	1.76	0.47	1054
29	18	3.43	3.40	0.99	833	3.15	3.12	0.99	884	2.91	2.88	0.99	918
29	20	3.61	3.14	0.87	867	3.36	2.92	0.87	910	3.12	2.71	0.87	961
29	22	3.82	2.86	0.75	901	3.57	2.68	0.75	952	3.33	2.49	0.75	986
29	24	4.03	2.54	0.63	935	3.78	2.38	0.63	978	3.57	2.25	0.63	1020
29	26	4.24	2.16	0.51	969	3.99	2.03	0.51	1012	3.75	1.91	0.51	1054
30	18	3.43	3.43	1.00	833	3.15	3.15	1.00	884	2.91	2.91	1.00	918
30	20	3.61	3.28	0.91	867	3.36	3.06	0.91	910	3.12	2.83	0.91	961
30	22	3.82	3.01	0.79	901	3.57	2.82	0.79	952	3.33	2.63	0.79	986
30	24	4.03	2.70	0.67	935	3.78	2.53	0.67	978	3.57	2.39	0.67	1020
30	26	4.24	2.33	0.55	969	3.99	2.19	0.55	1012	3.75	2.06	0.55	1054
31	18	3.43	3.43	1.00	833	3.15	3.15	1.00	884	2.91	2.91	1.00	918
31	20	3.61	3.42	0.95	867	3.36	3.19	0.95	910	3.12	2.96	0.95	961
31	22	3.82	3.17	0.83	901	3.57	2.96	0.83	952	3.33	2.76	0.83	986
31	24	4.03	2.86	0.71	935	3.78	2.68	0.71	978	3.57	2.53	0.71	1020
31	26	4.24	2.50	0.59	969	3.99	2.35	0.59	1012	3.75	2.21	0.59	1054
32	18	3.43	3.43	1.00	833	3.15	3.15	1.00	884	2.91	2.91	1.00	918
32	20	3.61	3.57	0.99	867	3.36	3.33	0.99	910	3.12	3.08	0.99	961
32	22	3.82	3.32	0.87	901	3.57	3.11	0.87	952	3.33	2.89	0.87	986
32	24	4.03	3.02	0.75	935	3.78	2.84	0.75	978	3.57	2.68	0.75	1020
32	26	4.24	2.67	0.63	969	3.99	2.51	0.63	1012	3.75	2.36	0.63	1054

NOTE: Q : Total capacity (kW) SHF : Sensible heat factor DB : Dry-bulb temperature
SHC : Sensible heat capacity (kW) INPUT : Total power input (W) WB : Wet-bulb temperature

PERFORMANCE DATA COOL operation at Rated frequency
MUZ-FD35VAH

CAPACITY:3.5(kW) SHF:0.85 INPUT:835(W)

		OUTDOOR DB(°C)															
INDOOR DB(°C)	INDOOR WB(°C)	21				25				27				30			
		Q	SHC	SHF	INPUT	Q	SHC	SHF	INPUT	Q	SHC	SHF	INPUT	Q	SHC	SHF	INPUT
21	18	4.11	2.76	0.67	668	3.94	2.64	0.67	701	3.78	2.53	0.67	735	3.64	2.44	0.67	768
21	20	4.29	2.36	0.55	701	4.11	2.26	0.55	743	3.99	2.19	0.55	760	3.85	2.12	0.55	793
22	18	4.11	2.92	0.71	668	3.94	2.80	0.71	701	3.78	2.68	0.71	735	3.64	2.58	0.71	768
22	20	4.29	2.53	0.59	701	4.11	2.43	0.59	743	3.99	2.35	0.59	760	3.85	2.27	0.59	793
22	22	4.46	2.10	0.47	726	4.31	2.02	0.47	772	4.20	1.97	0.47	793	4.03	1.89	0.47	827
23	18	4.11	3.08	0.75	668	3.94	2.95	0.75	701	3.78	2.84	0.75	735	3.64	2.73	0.75	768
23	20	4.29	2.70	0.63	701	4.11	2.59	0.63	743	3.99	2.51	0.63	760	3.85	2.43	0.63	793
23	22	4.46	2.28	0.51	726	4.31	2.20	0.51	772	4.20	2.14	0.51	793	4.03	2.05	0.51	827
24	18	4.11	3.25	0.79	668	3.94	3.11	0.79	701	3.78	2.99	0.79	735	3.64	2.88	0.79	768
24	20	4.29	2.87	0.67	701	4.11	2.76	0.67	743	3.99	2.67	0.67	760	3.85	2.58	0.67	793
24	22	4.46	2.45	0.55	726	4.31	2.37	0.55	772	4.20	2.31	0.55	793	4.03	2.21	0.55	827
24	24	4.69	2.02	0.43	760	4.52	1.94	0.43	802	4.41	1.90	0.43	827	4.27	1.84	0.43	868
25	18	4.11	3.41	0.83	668	3.94	3.27	0.83	701	3.78	3.14	0.83	735	3.64	3.02	0.83	768
25	20	4.29	3.04	0.71	701	4.11	2.92	0.71	743	3.99	2.83	0.71	760	3.85	2.73	0.71	793
25	22	4.46	2.63	0.59	726	4.31	2.54	0.59	772	4.20	2.48	0.59	793	4.03	2.37	0.59	827
25	24	4.69	2.20	0.47	760	4.52	2.12	0.47	802	4.41	2.07	0.47	827	4.27	2.01	0.47	868
26	18	4.11	3.58	0.87	668	3.94	3.43	0.87	701	3.78	3.29	0.87	735	3.64	3.17	0.87	768
26	20	4.29	3.22	0.75	701	4.11	3.08	0.75	743	3.99	2.99	0.75	760	3.85	2.89	0.75	793
26	22	4.46	2.81	0.63	726	4.31	2.71	0.63	772	4.20	2.65	0.63	793	4.03	2.54	0.63	827
26	24	4.69	2.39	0.51	760	4.52	2.30	0.51	802	4.41	2.25	0.51	827	4.27	2.18	0.51	868
26	26	4.83	1.88	0.39	802	4.69	1.83	0.39	843	4.62	1.80	0.39	868	4.48	1.75	0.39	893
27	18	4.11	3.74	0.91	668	3.94	3.58	0.91	701	3.78	3.44	0.91	735	3.64	3.31	0.91	768
27	20	4.29	3.39	0.79	701	4.11	3.25	0.79	743	3.99	3.15	0.79	760	3.85	3.04	0.79	793
27	22	4.46	2.99	0.67	726	4.31	2.88	0.67	772	4.20	2.81	0.67	793	4.03	2.70	0.67	827
27	24	4.69	2.58	0.55	760	4.52	2.48	0.55	802	4.41	2.43	0.55	827	4.27	2.35	0.55	868
27	26	4.83	2.08	0.43	802	4.69	2.02	0.43	843	4.62	1.99	0.43	868	4.48	1.93	0.43	893
28	18	4.11	3.91	0.95	668	3.94	3.74	0.95	701	3.78	3.59	0.95	735	3.64	3.46	0.95	768
28	20	4.29	3.56	0.83	701	4.11	3.41	0.83	743	3.99	3.31	0.83	760	3.85	3.20	0.83	793
28	22	4.46	3.17	0.71	726	4.31	3.06	0.71	772	4.20	2.98	0.71	793	4.03	2.86	0.71	827
28	24	4.69	2.77	0.59	760	4.52	2.66	0.59	802	4.41	2.60	0.59	827	4.27	2.52	0.59	868
28	26	4.83	2.27	0.47	802	4.69	2.20	0.47	843	4.62	2.17	0.47	868	4.48	2.11	0.47	893
29	18	4.11	4.07	0.99	668	3.94	3.90	0.99	701	3.78	3.74	0.99	735	3.64	3.60	0.99	768
29	20	4.29	3.73	0.87	701	4.11	3.58	0.87	743	3.99	3.47	0.87	760	3.85	3.35	0.87	793
29	22	4.46	3.35	0.75	726	4.31	3.23	0.75	772	4.20	3.15	0.75	793	4.03	3.02	0.75	827
29	24	4.69	2.95	0.63	760	4.52	2.84	0.63	802	4.41	2.78	0.63	827	4.27	2.69	0.63	868
29	26	4.83	2.46	0.51	802	4.69	2.39	0.51	843	4.62	2.36	0.51	868	4.48	2.28	0.51	893
30	18	4.11	4.11	1.00	668	3.94	3.94	1.00	701	3.78	3.78	1.00	735	3.64	3.64	1.00	768
30	20	4.29	3.90	0.91	701	4.11	3.74	0.91	743	3.99	3.63	0.91	760	3.85	3.50	0.91	793
30	22	4.46	3.53	0.79	726	4.31	3.40	0.79	772	4.20	3.32	0.79	793	4.03	3.18	0.79	827
30	24	4.69	3.14	0.67	760	4.52	3.03	0.67	802	4.41	2.95	0.67	827	4.27	2.86	0.67	868
30	26	4.83	2.66	0.55	802	4.69	2.58	0.55	843	4.62	2.54	0.55	868	4.48	2.46	0.55	893
31	18	4.11	4.11	1.00	668	3.94	3.94	1.00	701	3.78	3.78	1.00	735	3.64	3.64	1.00	768
31	20	4.29	4.07	0.95	701	4.11	3.91	0.95	743	3.99	3.79	0.95	760	3.85	3.66	0.95	793
31	22	4.46	3.70	0.83	726	4.31	3.57	0.83	772	4.20	3.49	0.83	793	4.03	3.34	0.83	827
31	24	4.69	3.33	0.71	760	4.52	3.21	0.71	802	4.41	3.13	0.71	827	4.27	3.03	0.71	868
31	26	4.83	2.85	0.59	802	4.69	2.77	0.59	843	4.62	2.73	0.59	868	4.48	2.64	0.59	893
32	18	4.11	4.11	1.00	668	3.94	3.94	1.00	701	3.78	3.78	1.00	735	3.64	3.64	1.00	768
32	20	4.29	4.24	0.99	701	4.11	4.07	0.99	743	3.99	3.95	0.99	760	3.85	3.81	0.99	793
32	22	4.46	3.88	0.87	726	4.31	3.75	0.87	772	4.20	3.65	0.87	793	4.03	3.50	0.87	827
32	24	4.69	3.52	0.75	760	4.52	3.39	0.75	802	4.41	3.31	0.75	827	4.27	3.20	0.75	868
32	26	4.83	3.04	0.63	802	4.69	2.95	0.63	843	4.62	2.91	0.63	868	4.48	2.82	0.63	893

NOTE: Q : Total capacity (kW) SHF : Sensible heat factor DB : Dry-bulb temperature
 SHC : Sensible heat capacity (kW) INPUT : Total power input (W) WB : Wet-bulb temperature

PERFORMANCE DATA COOL operation at Rated frequency
MUZ-FD35VAH

CAPACITY:3.5(kW) SHF:0.85 INPUT:835(W)

		OUTDOOR DB(°C)											
INDOOR DB (°C)	INDOOR WB (°C)	35				40				46			
		Q	SHC	SHF	INPUT	Q	SHC	SHF	INPUT	Q	SHC	SHF	INPUT
21	18	3.43	2.30	0.67	818	3.15	2.11	0.67	868	2.91	1.95	0.67	902
21	20	3.61	1.98	0.55	852	3.36	1.85	0.55	893	3.12	1.71	0.55	944
22	18	3.43	2.44	0.71	818	3.15	2.24	0.71	868	2.91	2.06	0.71	902
22	20	3.61	2.13	0.59	852	3.36	1.98	0.59	893	3.12	1.84	0.59	944
22	22	3.82	1.79	0.47	885	3.57	1.68	0.47	935	3.33	1.56	0.47	969
23	18	3.43	2.57	0.75	818	3.15	2.36	0.75	868	2.91	2.18	0.75	902
23	20	3.61	2.27	0.63	852	3.36	2.12	0.63	893	3.12	1.96	0.63	944
23	22	3.82	1.95	0.51	885	3.57	1.82	0.51	935	3.33	1.70	0.51	969
24	18	3.43	2.71	0.79	818	3.15	2.49	0.79	868	2.91	2.29	0.79	902
24	20	3.61	2.42	0.67	852	3.36	2.25	0.67	893	3.12	2.09	0.67	944
24	22	3.82	2.10	0.55	885	3.57	1.96	0.55	935	3.33	1.83	0.55	969
24	24	4.03	1.73	0.43	919	3.78	1.63	0.43	960	3.57	1.54	0.43	1002
25	18	3.43	2.85	0.83	818	3.15	2.61	0.83	868	2.91	2.41	0.83	902
25	20	3.61	2.56	0.71	852	3.36	2.39	0.71	893	3.12	2.21	0.71	944
25	22	3.82	2.25	0.59	885	3.57	2.11	0.59	935	3.33	1.96	0.59	969
25	24	4.03	1.89	0.47	919	3.78	1.78	0.47	960	3.57	1.68	0.47	1002
26	18	3.43	2.98	0.87	818	3.15	2.74	0.87	868	2.91	2.53	0.87	902
26	20	3.61	2.70	0.75	852	3.36	2.52	0.75	893	3.12	2.34	0.75	944
26	22	3.82	2.40	0.63	885	3.57	2.25	0.63	935	3.33	2.09	0.63	969
26	24	4.03	2.05	0.51	919	3.78	1.93	0.51	960	3.57	1.82	0.51	1002
26	26	4.24	1.65	0.39	952	3.99	1.56	0.39	994	3.75	1.46	0.39	1035
27	18	3.43	3.12	0.91	818	3.15	2.87	0.91	868	2.91	2.64	0.91	902
27	20	3.61	2.85	0.79	852	3.36	2.65	0.79	893	3.12	2.46	0.79	944
27	22	3.82	2.56	0.67	885	3.57	2.39	0.67	935	3.33	2.23	0.67	969
27	24	4.03	2.21	0.55	919	3.78	2.08	0.55	960	3.57	1.96	0.55	1002
27	26	4.24	1.82	0.43	952	3.99	1.72	0.43	994	3.75	1.61	0.43	1035
28	18	3.43	3.26	0.95	818	3.15	2.99	0.95	868	2.91	2.76	0.95	902
28	20	3.61	2.99	0.83	852	3.36	2.79	0.83	893	3.12	2.59	0.83	944
28	22	3.82	2.71	0.71	885	3.57	2.53	0.71	935	3.33	2.36	0.71	969
28	24	4.03	2.37	0.59	919	3.78	2.23	0.59	960	3.57	2.11	0.59	1002
28	26	4.24	1.99	0.47	952	3.99	1.88	0.47	994	3.75	1.76	0.47	1035
29	18	3.43	3.40	0.99	818	3.15	3.12	0.99	868	2.91	2.88	0.99	902
29	20	3.61	3.14	0.87	852	3.36	2.92	0.87	893	3.12	2.71	0.87	944
29	22	3.82	2.86	0.75	885	3.57	2.68	0.75	935	3.33	2.49	0.75	969
29	24	4.03	2.54	0.63	919	3.78	2.38	0.63	960	3.57	2.25	0.63	1002
29	26	4.24	2.16	0.51	952	3.99	2.03	0.51	994	3.75	1.91	0.51	1035
30	18	3.43	3.43	1.00	818	3.15	3.15	1.00	868	2.91	2.91	1.00	902
30	20	3.61	3.28	0.91	852	3.36	3.06	0.91	893	3.12	2.83	0.91	944
30	22	3.82	3.01	0.79	885	3.57	2.82	0.79	935	3.33	2.63	0.79	969
30	24	4.03	2.70	0.67	919	3.78	2.53	0.67	960	3.57	2.39	0.67	1002
30	26	4.24	2.33	0.55	952	3.99	2.19	0.55	994	3.75	2.06	0.55	1035
31	18	3.43	3.43	1.00	818	3.15	3.15	1.00	868	2.91	2.91	1.00	902
31	20	3.61	3.42	0.95	852	3.36	3.19	0.95	893	3.12	2.96	0.95	944
31	22	3.82	3.17	0.83	885	3.57	2.96	0.83	935	3.33	2.76	0.83	969
31	24	4.03	2.86	0.71	919	3.78	2.68	0.71	960	3.57	2.53	0.71	1002
31	26	4.24	2.50	0.59	952	3.99	2.35	0.59	994	3.75	2.21	0.59	1035
32	18	3.43	3.43	1.00	818	3.15	3.15	1.00	868	2.91	2.91	1.00	902
32	20	3.61	3.57	0.99	852	3.36	3.33	0.99	893	3.12	3.08	0.99	944
32	22	3.82	3.32	0.87	885	3.57	3.11	0.87	935	3.33	2.89	0.87	969
32	24	4.03	3.02	0.75	919	3.78	2.84	0.75	960	3.57	2.68	0.75	1002
32	26	4.24	2.67	0.63	952	3.99	2.51	0.63	994	3.75	2.36	0.63	1035

NOTE: Q : Total capacity (kW) SHF : Sensible heat factor DB : Dry-bulb temperature
 SHC : Sensible heat capacity (kW) INPUT : Total power input (W) WB : Wet-bulb temperature

PERFORMANCE DATA HEAT operation at Rated frequency

MUZ-FD25VA MUZ-FD25VAH

CAPACITY:3.2(kW) INPUT:610(W)

INDOOR DB(°C)	OUTDOOR WB(°C)													
	-10		-5		0		5		10		15		20	
	Q	INPUT	Q	INPUT	Q	INPUT	Q	INPUT	Q	INPUT	Q	INPUT	Q	INPUT
15	2.02	397	2.43	476	2.85	537	3.26	580	3.68	616	4.06	634	4.48	647
21	1.92	427	2.30	506	2.72	561	3.10	604	3.52	634	3.90	653	4.30	677
26	1.73	458	2.14	537	2.53	592	2.94	634	3.36	665	3.74	683	4.16	702

MUZ-FD35VA

CAPACITY:4.0(kW) INPUT:865(W)

INDOOR DB(°C)	OUTDOOR WB(°C)													
	-10		-5		0		5		10		15		20	
	Q	INPUT	Q	INPUT	Q	INPUT	Q	INPUT	Q	INPUT	Q	INPUT	Q	INPUT
15	2.52	562	3.04	675	3.56	761	4.08	822	4.60	874	5.08	900	5.60	917
21	2.40	606	2.88	718	3.40	796	3.88	856	4.40	900	4.88	926	5.38	960
26	2.16	649	2.68	761	3.16	839	3.68	900	4.20	943	4.68	969	5.20	995

MUZ-FD35VAH

CAPACITY:4.0(kW) INPUT:850(W)

INDOOR DB(°C)	OUTDOOR WB(°C)													
	-10		-5		0		5		10		15		20	
	Q	INPUT	Q	INPUT	Q	INPUT	Q	INPUT	Q	INPUT	Q	INPUT	Q	INPUT
15	2.52	553	3.04	663	3.56	748	4.08	808	4.60	859	5.08	884	5.60	901
21	2.40	595	2.88	706	3.40	782	3.88	842	4.40	884	4.88	910	5.38	944
26	2.16	638	2.68	748	3.16	825	3.68	884	4.20	927	4.68	952	5.20	978

NOTE: Q:Total capacity (kW) INPUT:Total power input (W) DB : Dry-bulb temperature WB : Wet-bulb temperature

MUZ-FD25VA
MUZ-FD25VAH

MUZ-FD35VA
MUZ-FD35VAH

9-1. Outdoor fan motor control

The fan motor turns ON/OFF, interlocking with the compressor.

[ON] The fan motor turns ON 5 seconds before the compressor starts up.

[OFF] The fan motor turns OFF 15 seconds after the compressor has stopped running.

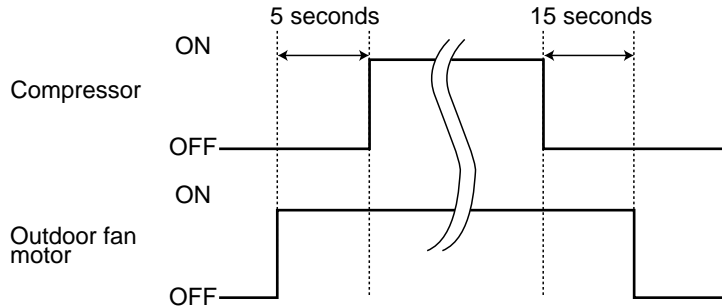

9-2. R.V. coil control

- Heating ON
- Cooling OFF
- Dry OFF

NOTE: The 4-way valve reverses for 5 seconds right before start-up of the compressor.

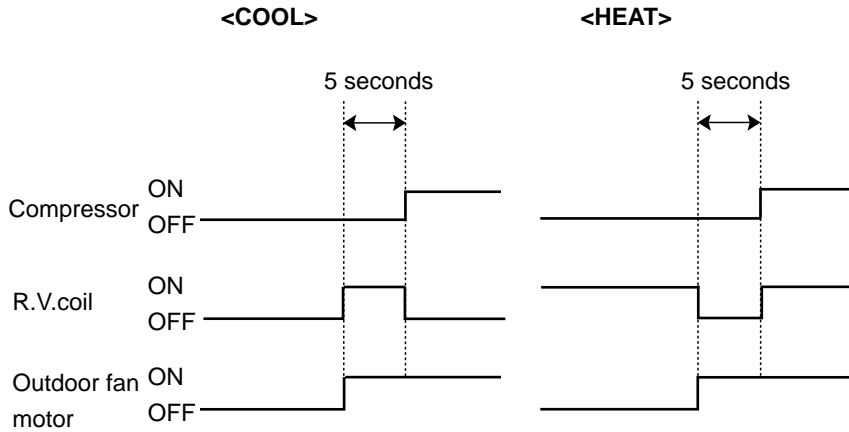

9-3. Relation between main sensor and actuator

Sensor	Purpose	Actuator					
		Compressor	LEV	Outdoor fan motor	R.V. coil	Indoor fan motor	Defrost heater
Discharge temperature thermistor	Protection	○	○				
Indoor coil temperature thermistor	Cooling : Coil frost prevention	○	○				
	Heating : High pressure protection	○	○				
Defrost thermistor	Cooling : High pressure protection	○	○				
	Heating : Defrosting	○	○	○	○	○	
Fin temperature thermistor	Protection	○	○	○			
Ambient temperature thermistor	Cooling : Low outside temperature operation	○	○	○			
	Heating : Defrosting (Heater)						○
Outdoor heat exchanger temperature thermistor	Low outside temperature operation	○	○	○			

10

SERVICE FUNCTIONS

MUZ-FD25VA
MUZ-FD25VAH

MUZ-FD35VA
MUZ-FD35VAH

10-1. CHANGE IN DEFROST SETTING

Changing defrost finish temperature

<JS> To change the defrost finish temperature, cut/solder the JS wire of the outdoor inverter P.C. board.
(Refer to 11-6-1.)

Jumper wire		Defrost finish temperature (°C)
JS	soldered (Initial setting)	5
	none (cut)	10

10-2. PRE-HEAT CONTROL SETTING

PRE-HEAT CONTROL

When moisture gets into the refrigerant cycle, it may interfere the start-up of the compressor at low outside temperature. The pre-heat control prevents this interference. The pre-heat control turns ON when outside temperature is 20°C or below. When pre-heat control is turned ON, compressor is energized. (about 50 W)

<JK> To activate the pre-heat control, cut the JK wire of the inverter P.C. board. (Refer to 11-6.1)

NOTE: When the inverter P.C. board is replaced, check the Jumper wires, and cut/solder them if necessary.

11

TROUBLESHOOTING

MUZ-FD25VA
MUZ-FD25VAH

MUZ-FD35VA
MUZ-FD35VAH

11-1. Cautions on troubleshooting

1. Before troubleshooting, check the following

- 1) Check the power supply voltage.
- 2) Check the indoor/outdoor connecting wire for miswiring.

2. Take care of the following during servicing

- 1) Before servicing the air conditioner, be sure to turn OFF the main unit first with the remote controller, and then after confirming the horizontal vane is closed, turn OFF the breaker and / or disconnect the power plug.
- 2) Be sure to turn OFF the power supply before removing the front panel, the cabinet, the top panel, and the electronic control P.C. board.
- 3) When removing the electrical parts, be careful to the residual voltage of smoothing capacitor.
- 4) When removing the electronic control P.C. board, hold the edge of the board with care NOT to apply stress on the components.
- 5) When connecting or disconnecting the connectors, hold the housing of the connector. DO NOT pull the lead wires.

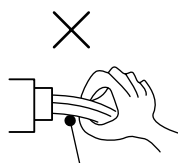

Lead wiring

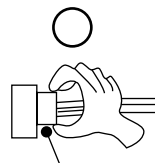

Housing point

3. Troubleshooting procedure

- 1) First, check if the OPERATION INDICATOR lamp on the indoor unit is flashing on and off to indicate an abnormality. To make sure, check how many times the abnormality indication is flashing on and off before starting service work.
- 2) Before servicing, check that the connector and terminal are connected properly.
- 3) When the electronic control P.C. board seems to be defective, check the copper foil pattern for disconnection and the components for bursting and discoloration.
- 4) Refer to 11-2. and 11-3.

11-2. Failure mode recall function

Outline of the function

This air conditioner can memorize the abnormal condition which has occurred once.

Even though LED indication listed on the troubleshooting check table (11-3.) disappears, the memorized failure details can be recalled.

This mode is very useful when the unit needs to be repaired for the abnormality which doesn't recur.

1. Flow chart of failure mode recall function for the indoor/outdoor unit

Operational procedure

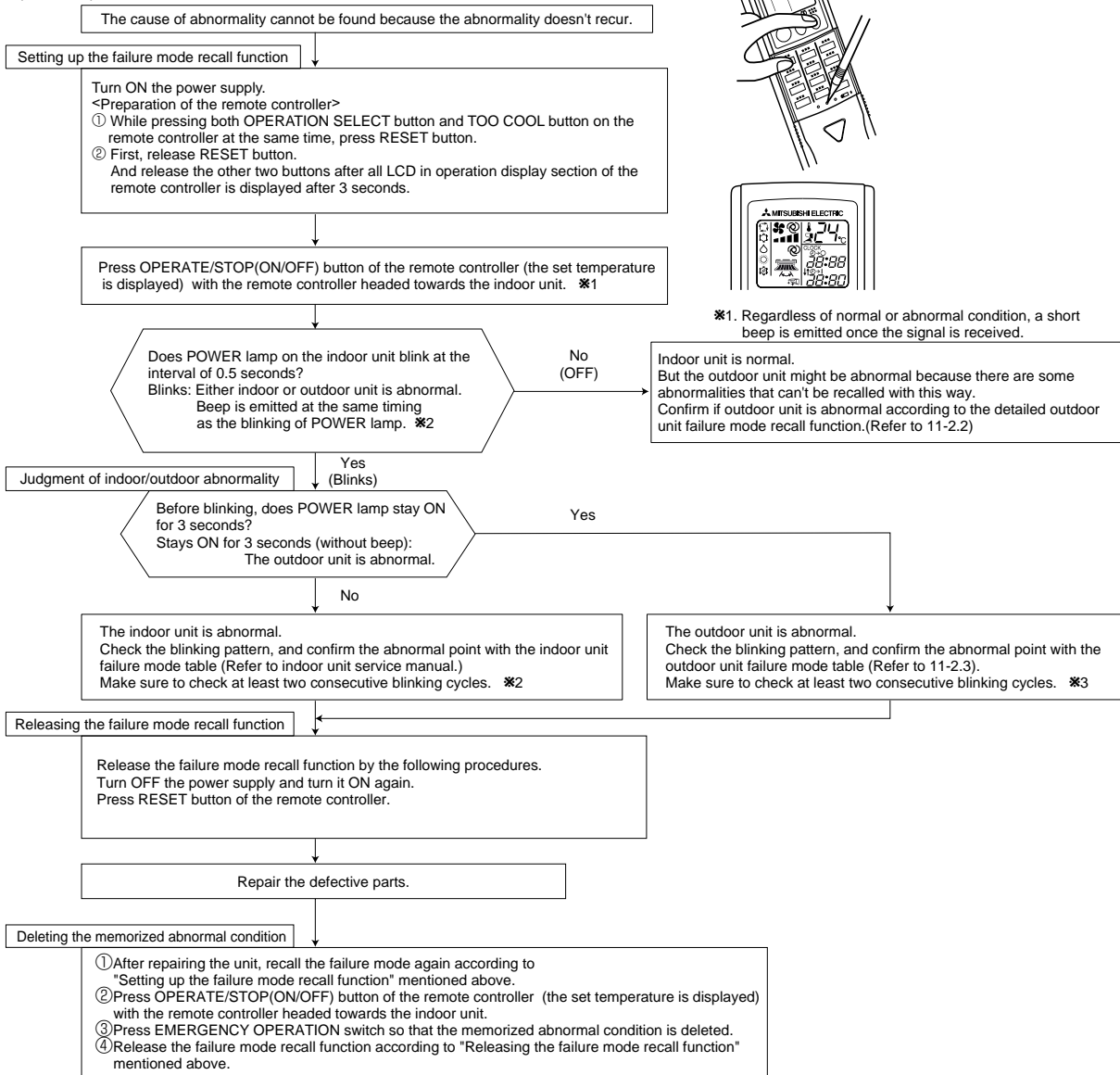

NOTE: 1. Make sure to release the failure mode recall function once it's set up, otherwise the unit cannot operate properly.
 2. If the abnormal condition is not deleted from the memory, the last abnormal condition is kept memorized.

※2. Blinking pattern when the indoor unit is abnormal:

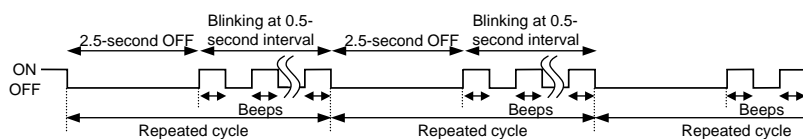

※3. Blinking pattern when the outdoor unit is abnormal:

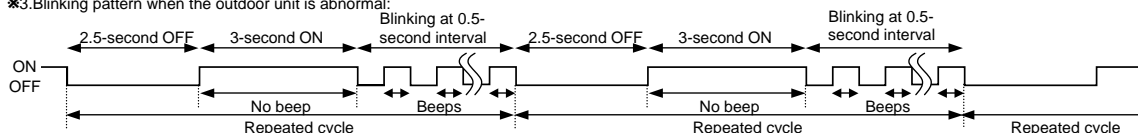

2. Flow chart of the detailed outdoor unit failure mode recall function

Operational procedure

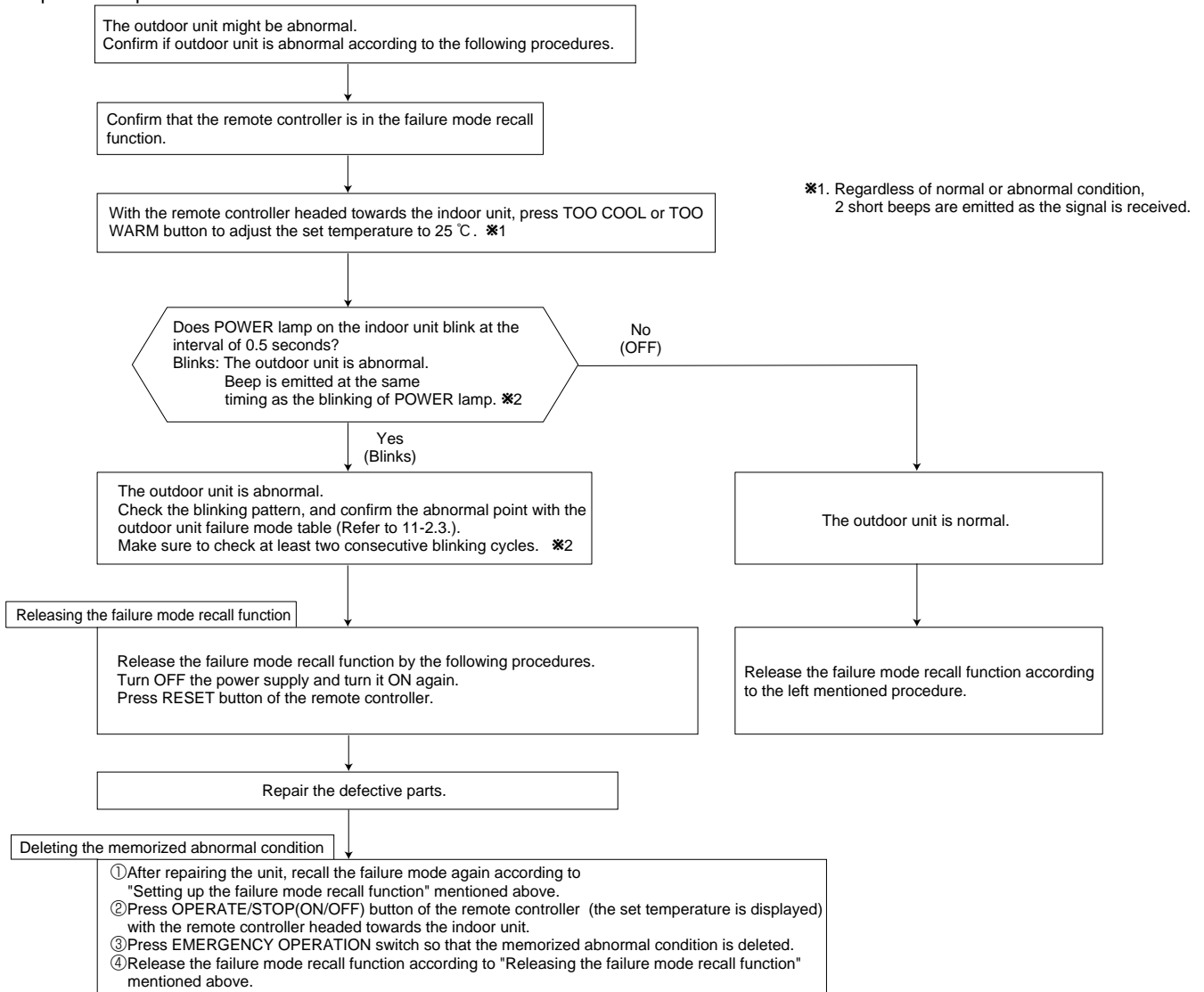

NOTE: 1. Make sure to release the failure mode recall function once it's set up, otherwise the unit cannot operate properly.
2. If the abnormal condition is not deleted from the memory, the last abnormal condition is kept memorized.

※2. Blinking pattern when outdoor unit is abnormal:

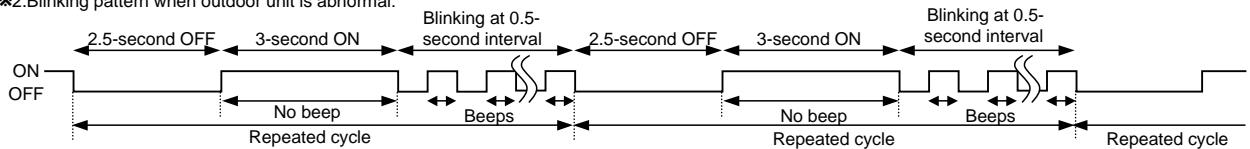

3. Outdoor unit failure mode table

POWER lamp (Indoor unit)	Abnormal point (Failure mode / protection)	LED indication (Outdoor P.C. board)	Condition	Correspondence	Indoor/outdoor unit failure mode recall function	Outdoor unit failure mode recall function
OFF	None (Normal)	—	—	—	—	—
2-time flash 2.5 seconds OFF	Outdoor power system	—	Overcurrent protection stop is continuously performed 3 times within 1 minute after the compressor gets started.	<ul style="list-style-type: none"> •Reconnect connectors. •Refer to 11-5. Ⓐ) "How to check inverter/compressor". •Check stop valve. 	○	○
3-time flash 2.5 seconds OFF	Discharge temperature thermistor	1-time flash every 2.5 seconds	Thermistor shorts or opens during compressor running.	<ul style="list-style-type: none"> •Refer to 11-5. Ⓒ) "Check of outdoor thermistors". ※Defective outdoor thermistors can be identified by checking the blinking pattern of LED. 	○	○
	Defrost thermistor	3-time flash 2.5 seconds OFF				
	Fin temperature thermistor	4-time flash 2.5 seconds OFF				
	P.C. board temperature thermistor	2-time flash 2.5 seconds OFF				
4-time flash 2.5 seconds OFF	Overcurrent	11-time flash 2.5 seconds OFF	Large current flows into intelligent power module.	<ul style="list-style-type: none"> •Reconnect compressor connector. •Refer to 11-5. Ⓐ) "How to check inverter/compressor". •Check stop valve. 	—	○
	Compressor synchronous abnormality (Compressor start-up failure protection)	12-time flash 2.5 seconds OFF	Waveform of compressor current is distorted.	<ul style="list-style-type: none"> •Reconnect compressor connector. •Refer to 11-5. Ⓐ) "How to check inverter/compressor". 	—	○
5-time flash 2.5 seconds OFF	Discharge temperature	—	Temperature of discharge temperature thermistor exceeds 116 °C, compressor stops. Compressor can restart if discharge temperature thermistor reads 100 °C or less 3 minutes later.	<ul style="list-style-type: none"> •Check refrigerant circuit and refrigerant amount. •Refer to 11-5. Ⓚ) "Check of LEV". 	—	○
6-time flash 2.5 seconds OFF	High pressure	—	Temperature indoor coil thermistor exceeds 70 °C in HEAT mode. Temperature defrost thermistor exceeds 70 °C in COOL mode.	<ul style="list-style-type: none"> •Check refrigerant circuit and refrigerant amount. •Check stop valve. 	—	○
7-time flash 2.5 seconds OFF	Fin temperature/ P.C. board temperature	7-time flash 2.5 seconds OFF	Temperature of fin temperature thermistor on the inverter P.C. board exceeds 75 °C ~80 °C, or temperature of P.C. board temperature thermistor on the inverter P.C. board exceeds 70 °C ~75 °C.	<ul style="list-style-type: none"> •Check around outdoor unit. •Check outdoor unit air passage. •Refer to 11-5. ①) "Check of outdoor fan motor". 	—	○
8-time flash 2.5 seconds OFF	Outdoor fan motor	—	Outdoor fan has stopped 3 times in a row within 30 seconds after outdoor fan start-up.	<ul style="list-style-type: none"> •Refer to 11-5. ①) "Check of outdoor fan motor". Refer to 11-5. ④) "Check of inverter P.C. board". 	—	○
9-time flash 2.5 seconds OFF	Nonvolatile memory data	5-time flash 2.5 seconds OFF	Nonvolatile memory data cannot be read properly.	<ul style="list-style-type: none"> •Replace the inverter P.C. board. 	○	○
10-time flash 2.5 seconds OFF	Discharge temperature	—	Temperature of discharge temperature thermistor has been 50 °C or less for 20 minutes.	<ul style="list-style-type: none"> •Refer to 11-5. Ⓚ) "Check of LEV". •Check refrigerant circuit and refrigerant amount. 	—	○
11-time flash 2.5 seconds OFF	DC voltage	8-time flash 2.5 seconds OFF	DC voltage of inverter cannot be detected normally.	<ul style="list-style-type: none"> •Refer to 11-5. Ⓐ) "How to check inverter/compressor". 	—	○
	Each phase current of compressor	9-time flash 2.5 seconds OFF	Each phase current of compressor cannot be detected normally.			
12-time flash 2.5 seconds OFF	Overcurrent Compressor open-phase	10-time flash 2.5 seconds OFF	Large current flows into intelligent power module (IPM). The open-phase operation of compressor is detected. The interphase short out occurs in the output of the intelligent power module (IPM). The compressor winding shorts out.	<ul style="list-style-type: none"> •Reconnect compressor connector. •Refer to 11-5. Ⓐ) "How to check inverter/compressor". 	—	○
14-time flash 2.5 seconds OFF	Stop valve (Closed valve)	14-time flash 2.5 seconds OFF	Closed valve is detected by compressor current.	<ul style="list-style-type: none"> •Check stop valve 	○	○

NOTE: Blinking patterns of this mode differ from the ones of Troubleshooting check table (11-3.).

11-3. Troubleshooting check table

No.	Symptom	LED indication	Abnormal point/ Condition	Condition	Correspondence	
1	Outdoor unit does not operate.	1-time flash every 2.5 seconds	Outdoor power system	Overcurrent protection stop is continuously performed 3 times within 1 minute after the compressor gets started, or failure of restart of compressor has repeated 24 times.	<ul style="list-style-type: none"> Reconnect connector of compressor. Refer to 11-5.Ⓐ "How to check inverter/ compressor". Check stop valve. 	
2			Outdoor thermistors	Discharge temperature thermistor, fin temperature thermistor, defrost thermistor, P.C. board temperature thermistor or ambient temperature thermistor shorts or opens during compressor running.	Refer to 11-5.Ⓒ "Check of outdoor thermistors".	
3			Outdoor control system	Nonvolatile memory data cannot be read properly. (POWER lamp of the indoor unit lights up or flashes 7-time.)	Replace inverter P.C. board.	
4		6-time flash 2.5 seconds OFF	Serial signal	The communication fails between the indoor and outdoor unit for 3 minutes.	Refer to 11-5.Ⓓ "How to check miswiring and serial signal error.	
5		11-time flash 2.5 seconds OFF	Stop valve/ Closed valve	Closed valve is detected by compressor current.	Check stop valve.	
6		14-time flash 2.5 seconds OFF	Outdoor unit (Other abnormality)	Outdoor unit is defective.	Refer to 11-2.2. "Flow chart of the detailed outdoor unit failure mode recall function".	
7	'Outdoor unit stops and restarts 3 minutes later' is repeated.	2-time flash 2.5 seconds OFF	Overcurrent protection	Large current flows into intelligent power module, or compressor repeats after 15 seconds when overcurrent protection occurs within 10 seconds after compressor starts. (Repeated 24 times at Maximum)	<ul style="list-style-type: none"> Reconnect connector of compressor. Refer to 11-5.Ⓐ "How to check inverter/compressor". Check stop valve. 	
8		3-time flash 2.5 seconds OFF	Discharge temperature overheat protection	Temperature of discharge temperature thermistor exceeds 116°C, compressor stops. Compressor can restart if discharge temperature thermistor reads 100°C or less 3 minutes later.	<ul style="list-style-type: none"> Check refrigerant circuit and refrigerant amount. Refer to 11-5.Ⓒ "Check of LEV". 	
9		4-time flash 2.5 seconds OFF	Fin temperature /P.C. board temperature thermistor overheat protection	Temperature of fin temperature thermistor on the heat sink exceeds 75°C ~ 80°C or temperature of P.C. board temperature thermistor on the inverter P.C.board exceeds 70°C ~ 75°C.	<ul style="list-style-type: none"> Check around outdoor unit. Check outdoor unit air passage. Refer to 11-5.Ⓒ "Check of outdoor fan motor". 	
10		5-time flash 2.5 seconds OFF	High pressure protection	Indoor coil thermistor exceeds 70°C in HEAT mode. Defrost thermistor exceeds 70°C in COOL mode.	<ul style="list-style-type: none"> Check refrigerant circuit and refrigerant amount. Check stop valve. 	
11		8-time flash 2.5 seconds OFF	Compressor synchronous abnormality	The waveform of compressor current is distorted.	<ul style="list-style-type: none"> Reconnect connector of compressor. Refer to 11-5.Ⓐ "How to check inverter/compressor". 	
12		10-time flash 2.5 seconds OFF	Outdoor fan motor	Outdoor fan has stopped 3 times in a row within 30 seconds after outdoor fan start-up.	<ul style="list-style-type: none"> Refer to 11-5.Ⓒ "Check of outdoor fan motor." Refer to 11-5.Ⓓ "Check of inverter P.C. board." 	
13		12-time flash 2.5 seconds OFF	Each phase current of compressor	Each phase current of compressor cannot be detected normally	Refer to 11-5.Ⓐ "How to check inverter/compressor".	
14		13-time flash 2.5 seconds OFF	DC voltage	DC voltage of inverter cannot be detected normally.	Refer to 11-5.Ⓐ "How to check inverter/compressor".	
15		Outdoor unit operates.	1-time flash 2.5 seconds OFF	Frequency drop by current protection	Current from power outlet reaches the protection current, and compressor frequency lowers.	<ul style="list-style-type: none"> The unit is normal, but check the following. Check if indoor filters are clogged. Check if refrigerant is short. Check if indoor/outdoor unit air circulation is short cycled.
16			3-time flash 2.5 seconds OFF	Frequency drop by high pressure protection	Temperature of indoor coil thermistor exceeds 55°C in HEAT mode, compressor frequency lowers.	
17	4-time flash 2.5 seconds OFF		Frequency drop by defrosting in COOL mode	Indoor coil thermistor reads 8°C or less in COOL mode, compressor frequency lowers.		
18	Outdoor unit operates.	7-time flash 2.5 seconds OFF	Low discharge temperature protection	Temperature of discharge temperature thermistor has been 50°C or less for 20 minutes.	<ul style="list-style-type: none"> Refer to 11-5.Ⓒ "Check of LEV". Check refrigerant circuit and refrigerant amount. 	
19		8-time flash 2.5 seconds OFF	PAM protection PAM: Pulse Amplitude Modulation	The overcurrent flows into IGBT(Insulated Gate Bipolar transistor : TR821) or when the bus-bar voltage reaches 320 V or more, PAM stops and restarts.	<ul style="list-style-type: none"> This is not malfunction. PAM protection will be activated in the following cases: Ⓐ Instantaneous power voltage drop (Short time power failure) Ⓑ When the power supply voltage is high. 	
20		9-time flash 2.5 seconds OFF	Inverter check mode	The connector of compressor is disconnected, inverter check mode starts.	Check if the connector of the compressor is correctly connected. Refer to 11-5.Ⓐ "How to check inverter/ compressor".	

NOTE: 1. The location of LED is illustrated at the right figure. Refer to 11-6.1.
2. LED is lighted during normal operation.

The flashing frequency shows the number of times the LED blinks after every 2.5-second OFF.
(Example) When the flashing frequency is "2".

Inverter P.C. board (Parts side)

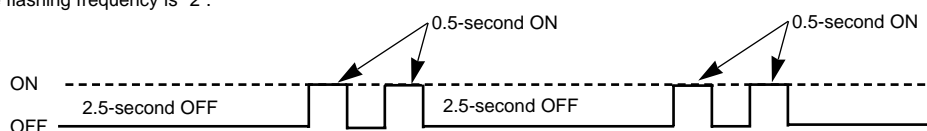
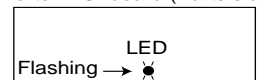

11-4. Trouble criterion of main parts

MUZ-FD25VA
MUZ-FD25VAH

MUZ-FD35VA
MUZ-FD35VAH

Part name	Check method and criterion	Figure				
Defrost thermistor (RT61) Ambient temperature thermistor (RT65) Outdoor heat exchanger temperature thermistor (RT68)	Measure the resistance with a tester. Refer to 11-7. "Test point diagram and voltage", 1. "Inverter P.C. board", the chart of thermistor.					
Discharge temperature thermistor (RT62)	Measure the resistance with a tester. Before measurement, hold the thermistor with your hands to warm it up.					
Fin temperature thermistor (RT64)	Refer to 11-7. "Test point diagram and voltage", 1. "Inverter P.C. board", the chart of thermistor.					
Compressor (MC)	Measure the resistance between the terminals with a tester. (Part temperature $-20 \sim 40 \text{ }^{\circ}\text{C}$) <table border="1" style="margin-left: 20px;"> <tr> <td></td> <td style="text-align: center;">Normal</td> </tr> <tr> <td>U-V U-W V-W</td> <td style="text-align: center;">0.78 ~ 1.11 Ω</td> </tr> </table>		Normal	U-V U-W V-W	0.78 ~ 1.11 Ω	
	Normal					
U-V U-W V-W	0.78 ~ 1.11 Ω					
Outdoor fan motor (MF)	Measure the resistance between the terminals with a tester. (Part temperature $-20 \sim 40 \text{ }^{\circ}\text{C}$) <table border="1" style="margin-left: 20px;"> <tr> <td>Color of the lead wire</td> <td style="text-align: center;">Normal</td> </tr> <tr> <td>WHT – BLK BLK – RED RED – WHT</td> <td style="text-align: center;">11 ~ 16 Ω</td> </tr> </table>	Color of the lead wire	Normal	WHT – BLK BLK – RED RED – WHT	11 ~ 16 Ω	
Color of the lead wire	Normal					
WHT – BLK BLK – RED RED – WHT	11 ~ 16 Ω					
R.V. coil (21S4)	Measure the resistance between the terminals with a tester. (Part temperature $-10 \sim 40 \text{ }^{\circ}\text{C}$) <table border="1" style="margin-left: 20px;"> <tr> <td></td> <td style="text-align: center;">Normal</td> </tr> <tr> <td></td> <td style="text-align: center;">1.19 ~ 1.78 kΩ</td> </tr> </table>		Normal		1.19 ~ 1.78 k Ω	
	Normal					
	1.19 ~ 1.78 k Ω					
Expansion valve coil (LEV)	Measure the resistance with a tester. (Part temperature $-10 \sim 40 \text{ }^{\circ}\text{C}$) <table border="1" style="margin-left: 20px;"> <tr> <td>Color of the lead wire</td> <td style="text-align: center;">Normal</td> </tr> <tr> <td>WHT – RED RED – ORN YLW – BRN BRN – BLU</td> <td style="text-align: center;">37 ~ 54 Ω</td> </tr> </table>	Color of the lead wire	Normal	WHT – RED RED – ORN YLW – BRN BRN – BLU	37 ~ 54 Ω	
Color of the lead wire	Normal					
WHT – RED RED – ORN YLW – BRN BRN – BLU	37 ~ 54 Ω					
Defrost heater (H) MUZ-FD25/35VAH	Measure the resistance with a tester. (Part temperature $-10 \sim 40 \text{ }^{\circ}\text{C}$) <table border="1" style="margin-left: 20px;"> <tr> <td></td> <td style="text-align: center;">Normal</td> </tr> <tr> <td></td> <td style="text-align: center;">349 ~ 428 Ω</td> </tr> </table>		Normal		349 ~ 428 Ω	
	Normal					
	349 ~ 428 Ω					

11-5. Troubleshooting flow

**POWER lamp flashes 5-times.
Outdoor unit does not operate.**

A How to check inverter/ compressor

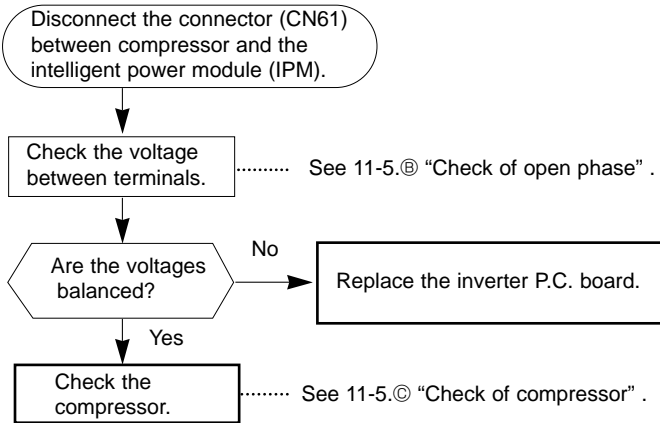

B Check of open phase

- With the connector between the compressor and the intelligent power module disconnected, activate the inverter and check if the inverter is normal by measuring the balance of voltage between the terminals.

Output voltage 115 V

<< Operation method >>

Start cooling or heating operation by pressing EMERGENCY OPERATION switch on the indoor unit. (Test run operation : refer to 8-3.)

<< Measurement point >>

at 3 points

BLK (U)-WHT (V)

BLK (U)-RED (W)

WHT(V)-RED (W)

※ Measure AC voltage between the lead wires at 3 points.

9-time flash



- NOTE:**
1. Output voltage varies according to power supply voltage.
 2. Measure the voltage by analog type tester.
 3. During this check, LED of inverter P.C. board flashes 9 times. (Refer to 11-6.1.)

C Check of compressor

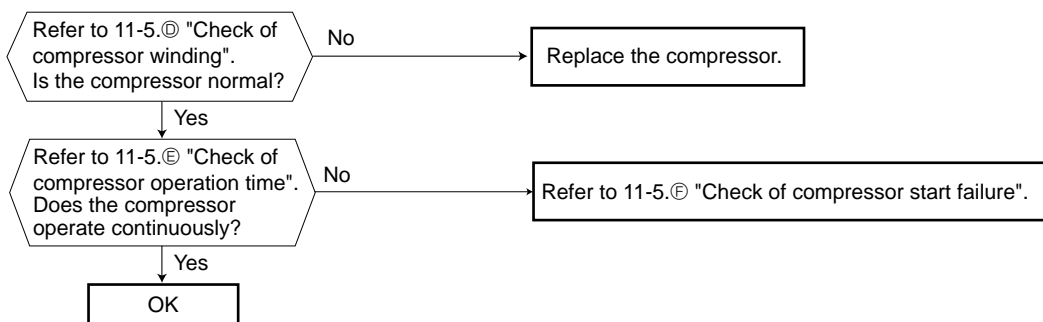

D Check of compressor winding

- Disconnect the connector (CN61) between the compressor and intelligent power module, and measure the resistance between the compressor terminals.

<<Measurement point>>

at 3 points

BLK-WHT

BLK-RED

WHT-RED

* Measure the resistance between the lead wires at 3 points.

<<Judgement>>

Refer to 11-4.

0[Ω]Abnormal [short]

Infinite[Ω]Abnormal [open]

NOTE: 1. Be sure to zero the ohmmeter before measurement.

E Check of compressor operation time

- Connect the compressor and activate the inverter. Then measure the time until the inverter stops due to over current.

<<Operation method>>

Start heating or cooling operation by pressing EMERGENCY

OPERATION switch on the indoor unit.

(Test run operation : Refer to 8-3.)

<<Measurement>>

Measure the time from the start of compressor to the stop of compressor due to over current.

<<Judgement>>

For reference

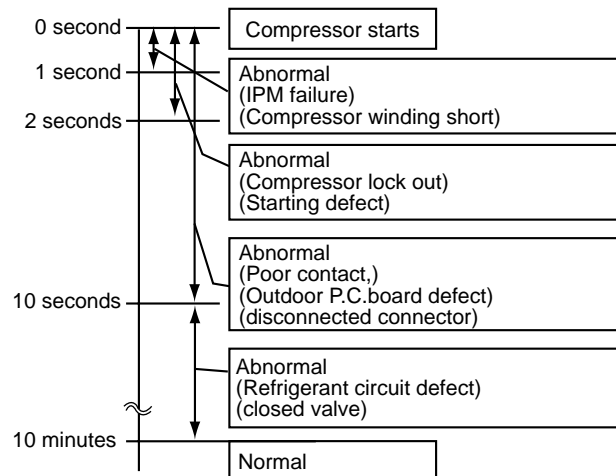

F Check of compressor start failure

Confirm that ①~④ is normal.

•Electrical circuit check

①Contact of the compressor connector (including CN61)

②Output voltage of inverter P.C.board and balance of them (See 11-5.③)

③Direct current voltage between DB61(+) and (-) on inverter P.C.board

④Voltage between outdoor terminal block S1-S2

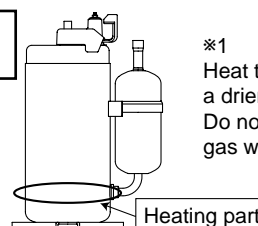
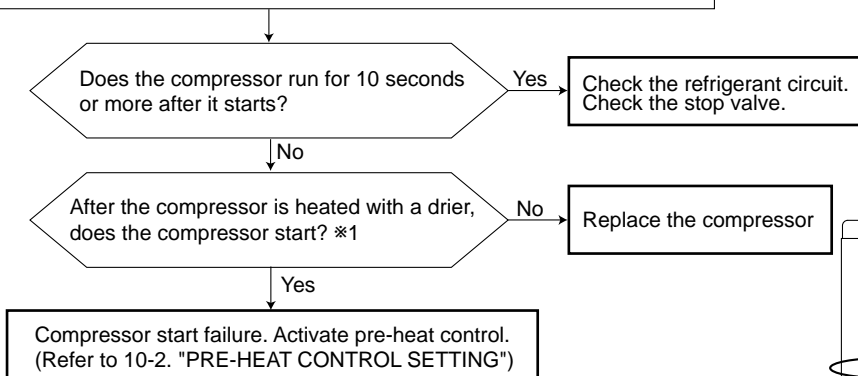

*1
Heat the compressor with a drier for about 20 minutes. Do not recover refrigerant gas while heating.

**POWER lamp flashes 6-time.
The thermistors in the outdoor unit are abnormal.**

Ⓒ Check of outdoor thermistors

Disconnect the connector of thermistor in the outdoor P.C.board (see below table), and measure the resistance of thermistor.

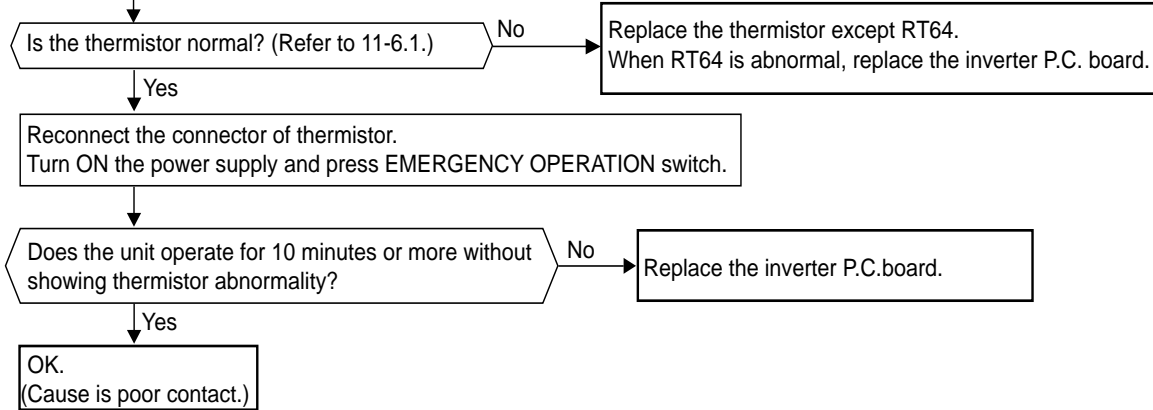

Thermistor			Board
Defrost	RT61	Between CN641 pin1 and pin2	Inverter P.C. board
Discharge temperature	RT62	Between CN641 pin3 and pin4	
Fin temperature	RT64	Between CN642 pin1 and pin2	
Ambient temperature	RT65	Between CN643 pin1 and pin2	
Outdoor heat exchanger temperature	RT68	Between CN644 pin1 and pin3	

Ⓓ Check of R.V. coil

- * First of all, measure the resistance of R.V. coil to check if the coil is defective. Refer to 11-4.
- * In case CN721 is not connected or R.V. coil is open, voltage is generated between the terminal pins of the connector although any signal is not being transmitted to R.V. coil. Check if CN721 is connected.

Unit operates COOL mode even if it is set to HEAT mode.

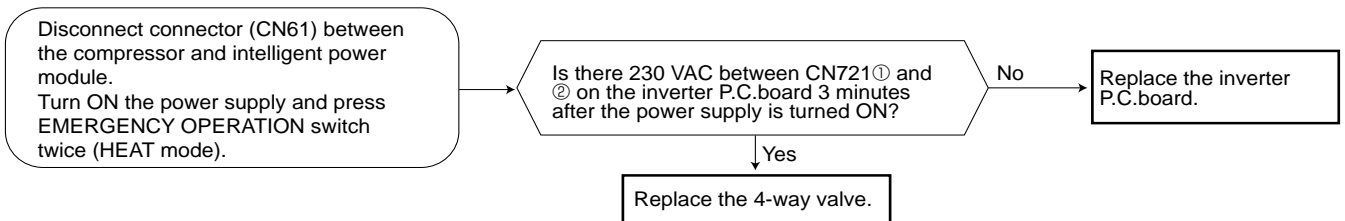

Unit operates HEAT mode even if it is set to COOL mode.

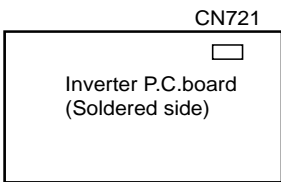
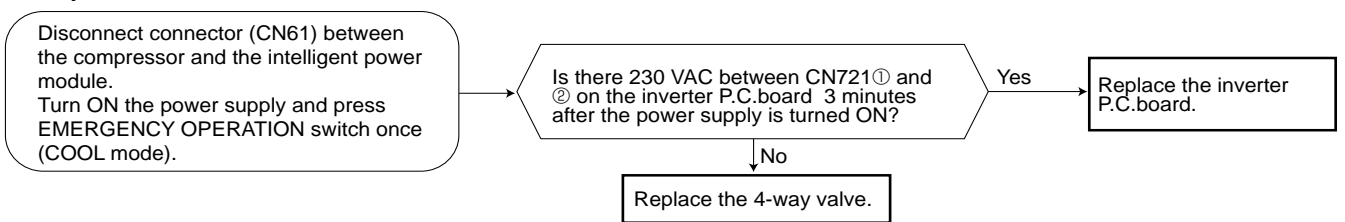

Outdoor fan motor does not operate.

ⓘ Check of outdoor fan motor

Disconnect CN932 from the inverter P.C. board, and measure the resistance of the outdoor fan motor.

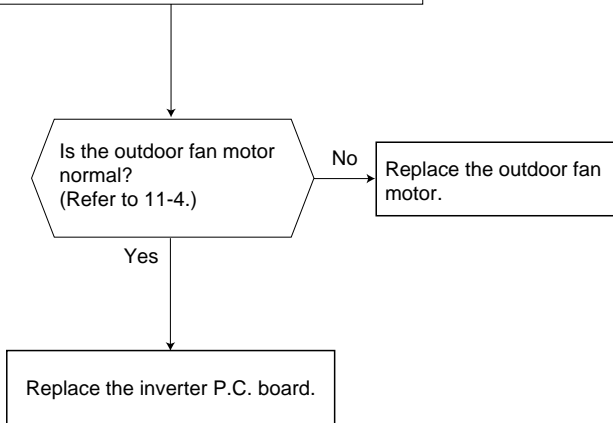

Inverter does not operate.

⓵ Check of power supply

Disconnect the connector (CN61) between compressor and intelligent power module. Turn ON power supply and press EMERGENCY OPERATION switch.

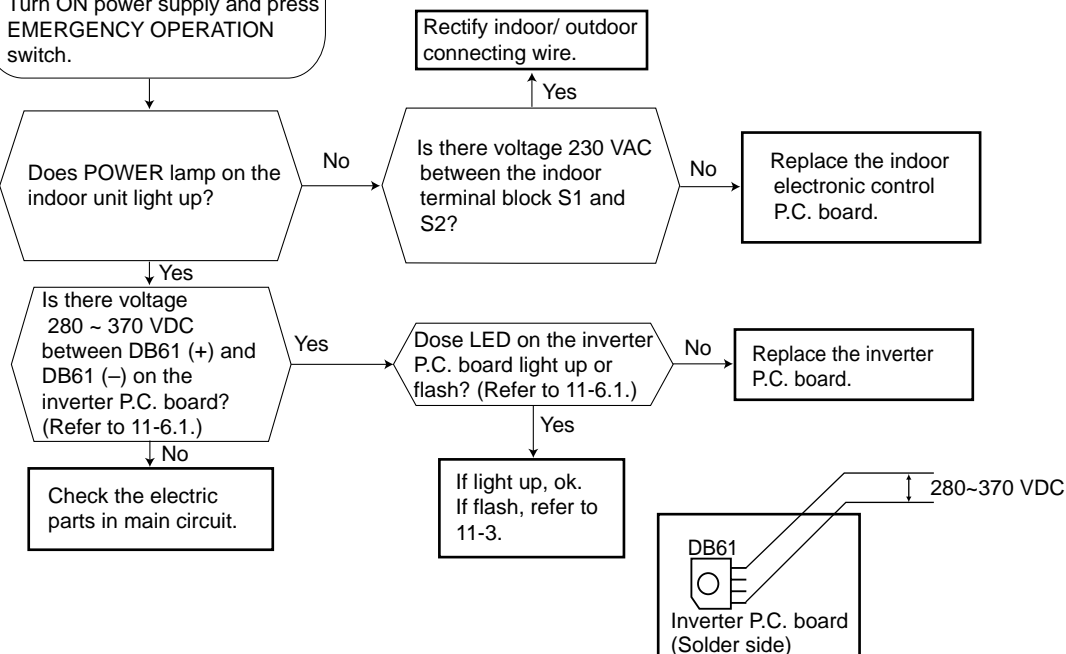

Heating/Cooling does not work sufficiently.

K Check of LEV (Expansion valve)

Turn ON the power supply.
 <Preparation of the remote controller>
 ① While pressing both OPERATION SELECT button and TOO COOL button on the remote controller at the same time, press RESET button.
 ② First, release RESET button.
 And release the other two buttons after all LCD except the set temperature in operation display section of the remote controller is displayed after 3 seconds.

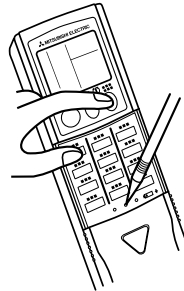

Press OPERATE/STOP(ON/OFF) button of the remote controller (the set temperature is displayed) with the remote controller headed towards the indoor unit. *1

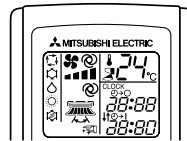

*1. Regardless of normal or abnormal condition, a short beep is emitted once the signal is received.

Expansion valve operates in full-opening direction.

Do you hear the expansion valve "click, click....."?
 Do you feel the expansion valve vibrate on touching it?

Yes → OK

No

Is LEV properly fixed to the expansion valve?

No → Properly fix the LEV to the expansion valve.

Yes

Does the resistance of LEV have the characteristics? (Refer to 11-4.)

Yes → Measure each voltage between connector pins of CN724 on the inverter P.C. board.

Measure each voltage between connector pins of CN724 on the inverter P.C. board.

- 1.Pin③(-) – Pin①(+)
- 2.Pin④(-) – Pin①(+)
- 3.Pin⑤(-) – Pin①(+)
- 4.Pin⑥(-) – Pin①(+)

Is there about 3~5 VAC between each?
NOTE: Measure the voltage by an analog tester.

No → Replace the LEV.

Yes → Replace the LEV.

No → Replace the inverter P.C. board.

NOTE : After check of LEV, do the undermentioned operations.
 1. Turn OFF the power supply and turn ON it again.
 2. Press RESET button on the remote controller.

Outdoor fan motor does not operate , or stops immediately after starting up.

Ⓐ Check of inverter P.C. board

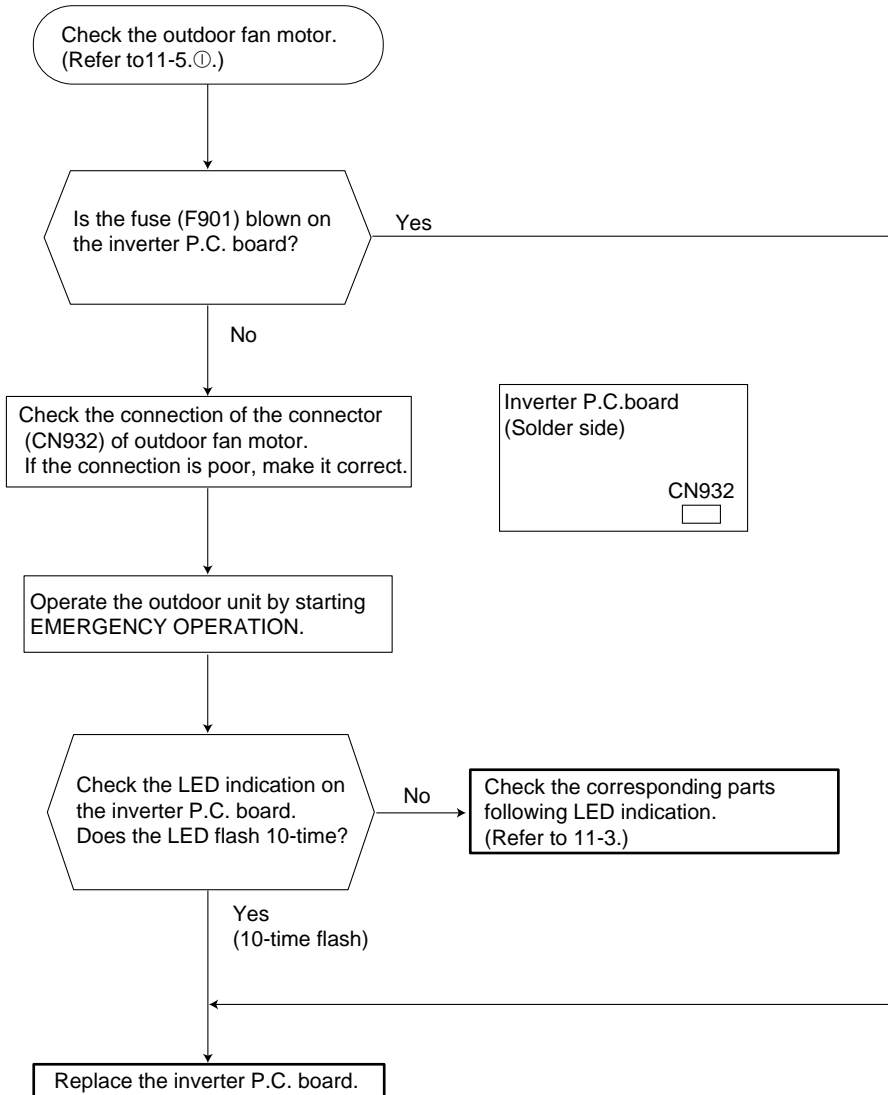

- Unit cannot operate neither by the remote controller nor by EMERGENCY OPERATION switch.
Indoor unit does not operate.
- POWER lamp flashes ON and OFF every 0.5-second.
Outdoor unit doesn't operate.

M How to check miswiring and serial signal error (when outdoor unit does not work)

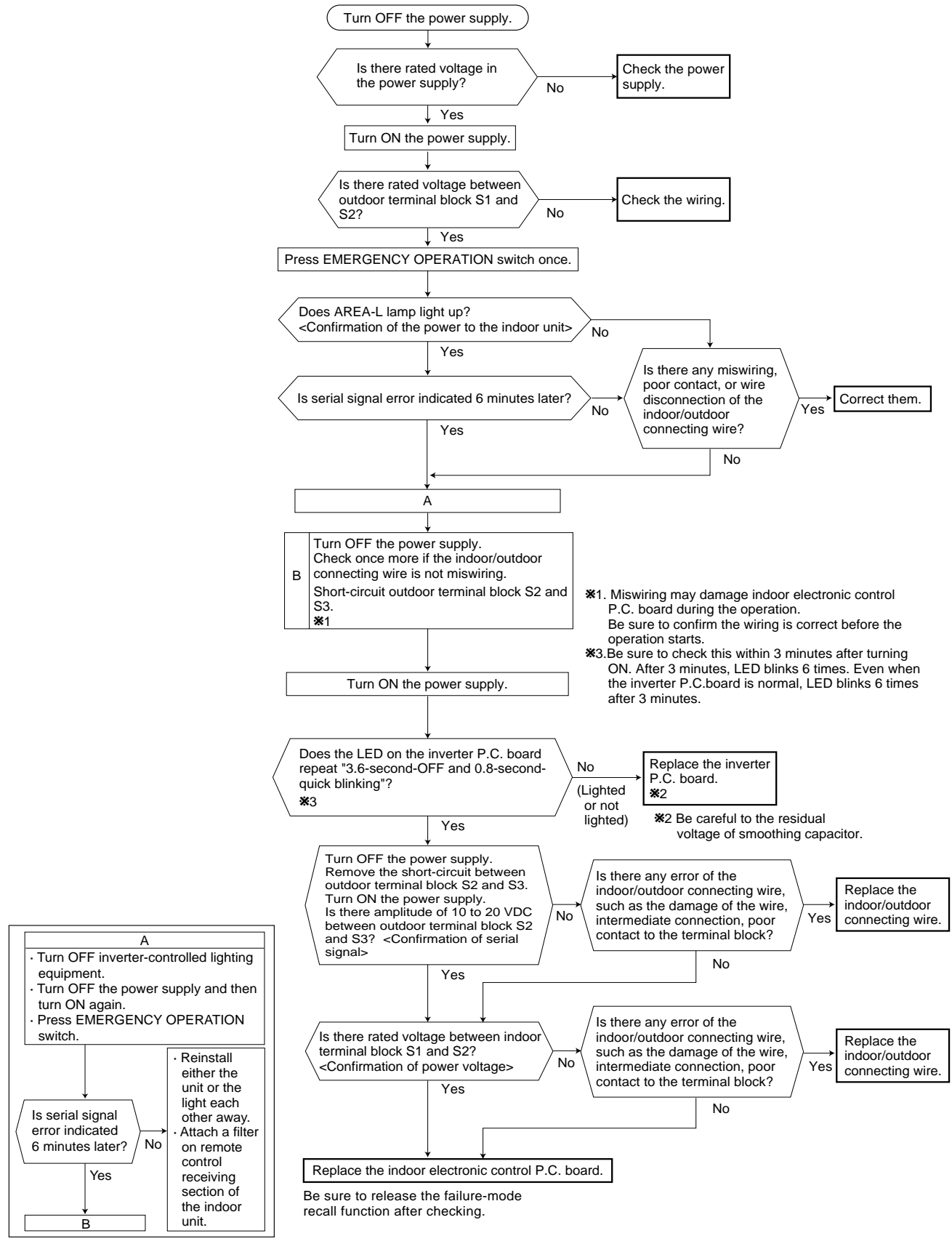

N Electromagnetic noise enters into TV sets or radios

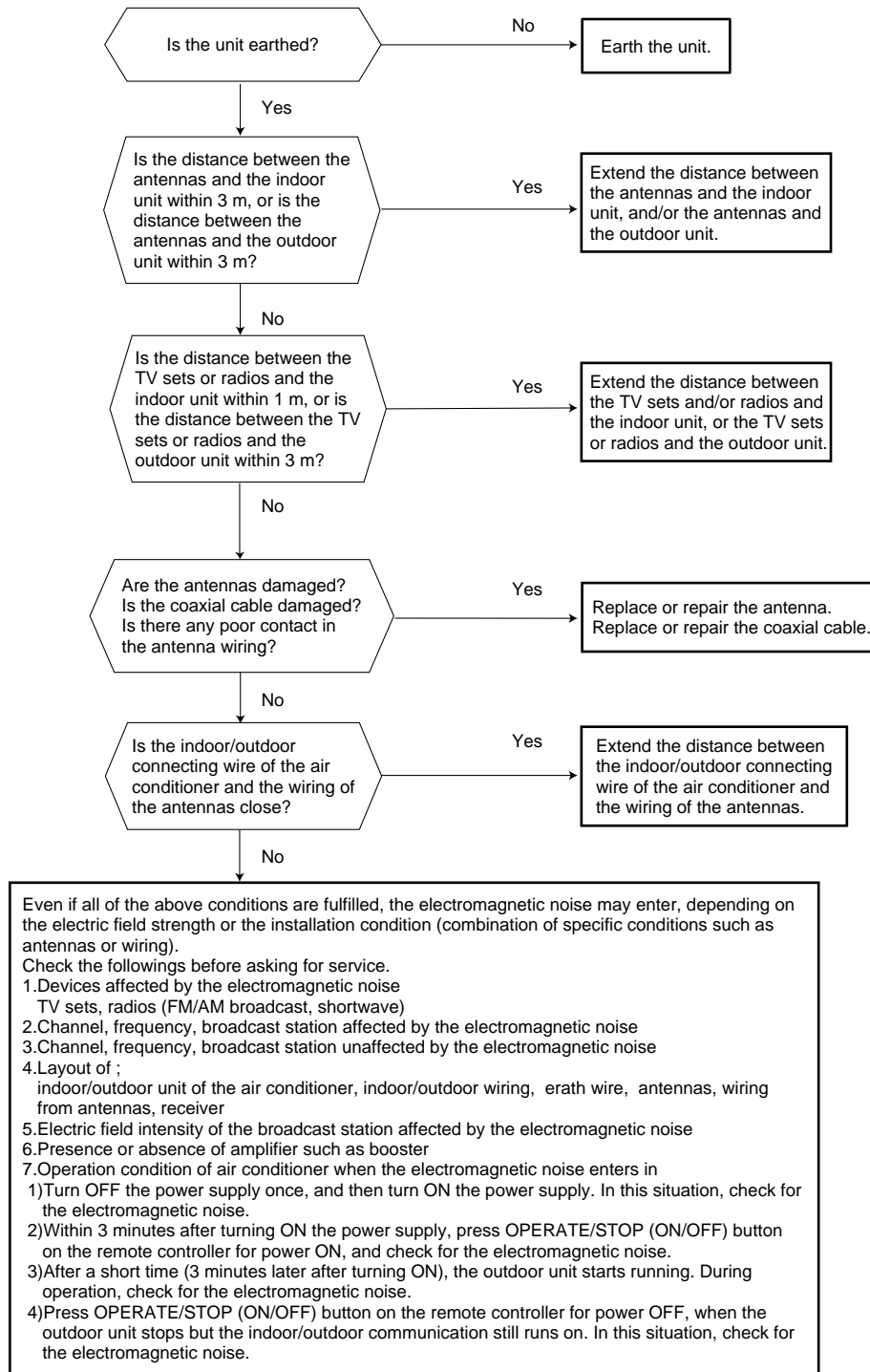



Outdoor base gets frozen.

⊙ Check of defrost heater

MUZ-FD25VAH MUZ-FD35VAH

Check the following points before checking electric continuity.

- 1) Does the resistance of ambient temperature thermistor have the characteristics? Refer to 11-6.1.
- 2) Is the resistance of defrost heater normal? Refer to 11-4.
- 3) Does the heater protector remain conducted (not open)?
- 4) Are both ambient temperature thermistor and circuit of defrost heater securely connected to connectors?

In HEAT mode, for more than 5 minutes, let the ambient temperature thermistor continue to read 5 °C or below, and let the defrost thermistor continue to read -1 °C or below.

NOTE: In case both thermistors are more than the above temperature, cool them with cold water etc...

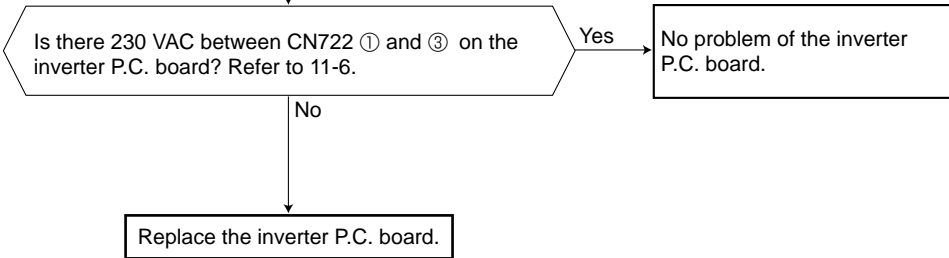

11-6. Test point diagram and voltage
 1. Inverter P.C. board

MUZ-FD25VA MUZ-FD35VA
MUZ-FD25VAH MUZ-FD35VAH

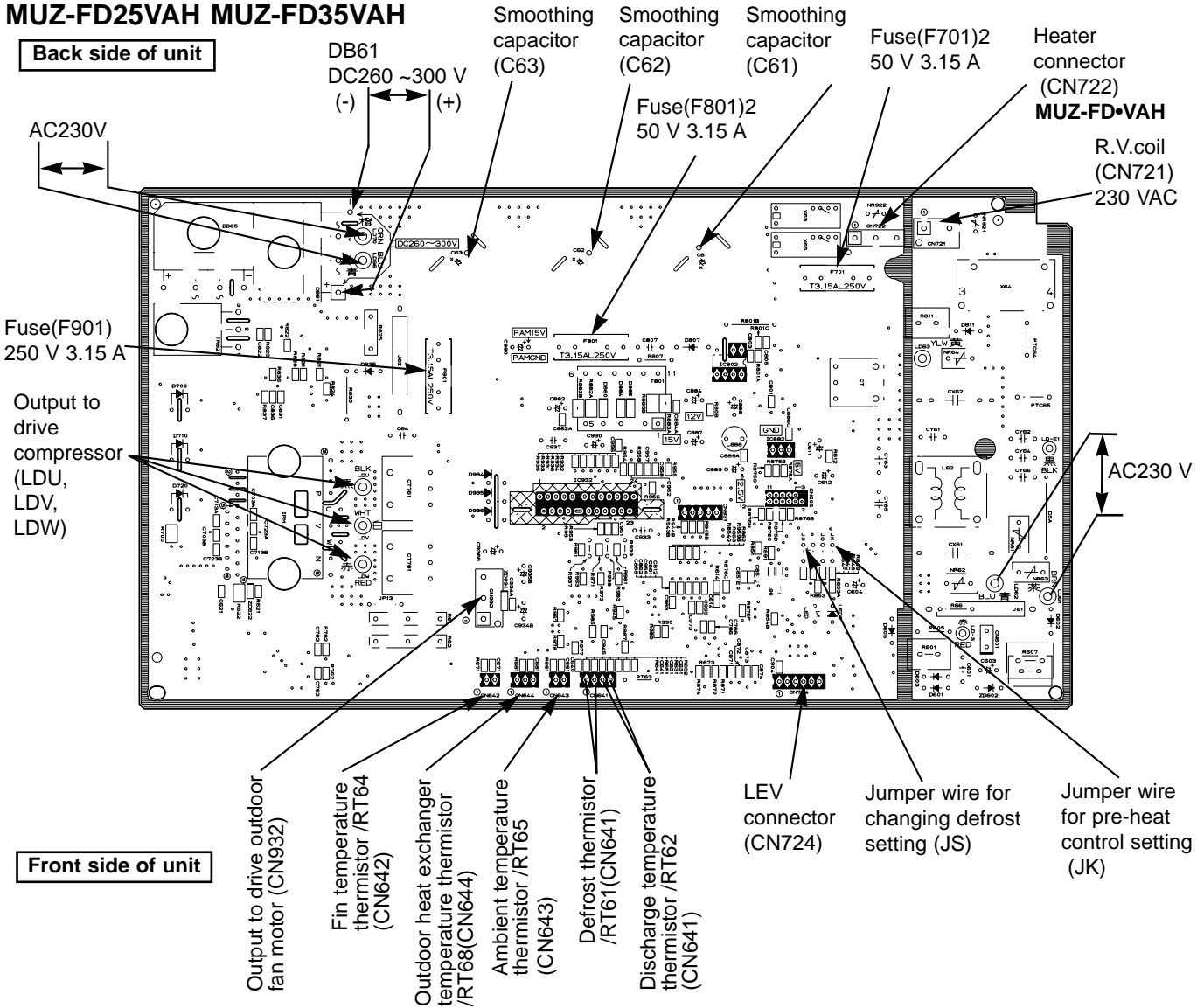

Defrost thermistor(RT61)
 Ambient temperature thermistor(RT65)
 Outdoor heat exchanger temperature thermistor(RT68)

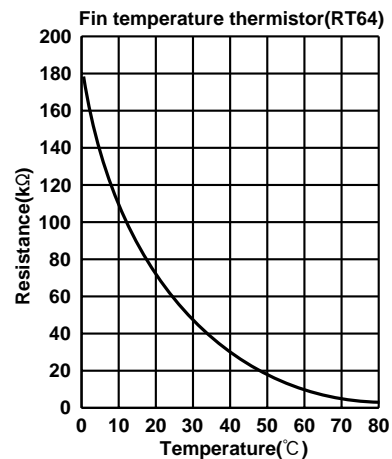
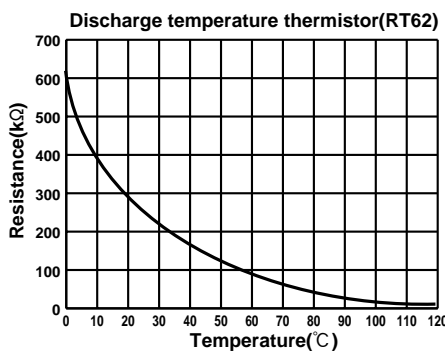
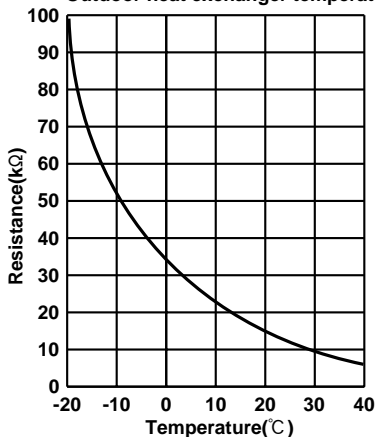

<"Terminal with locking mechanism" Detaching points>

The terminal which has the locking mechanism can be detached as shown below.
There are two types (Refer to (1) and (2)) of the terminal with locking mechanism.
The terminal without locking mechanism can be detached by pulling it out.
Check the shape of the terminal before detaching.

(1) Slide the sleeve and check if there is a locking lever or not.

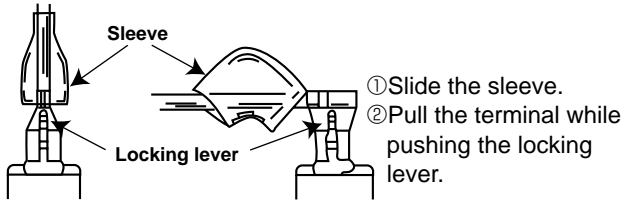

(2) The terminal with this connector has the locking mechanism.

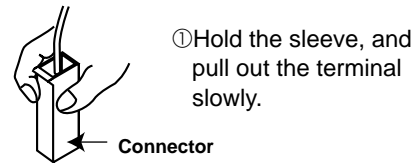

12-1. MUZ-FD25VA MUZ-FD25VAH MUZ-FD35VA MUZ-FD35VAH

NOTE : Turn OFF power supply before disassembling.

OPERATING PROCEDURE	PHOTOS
<p>1. Removing the cabinet</p> <ol style="list-style-type: none"> (1) Remove the screw fixing the service panel. (See Photo 2.) (2) Pull down the service panel and remove it. (See Photo 2.) (3) Disconnect the power supply and indoor/outdoor connecting wire. (4) Remove the screws fixing the top panel. (See Photo 1.) (5) Remove the top panel. (See Photo 1.) (6) Remove the screws fixing the cabinet. (7) Remove the cabinet. (8) Remove the screws fixing the back panel. (9) Remove the back panel. 	<p>Photo 1</p> <p>Photo 2</p>

OPERATING PROCEDURE

2. Removing the inverter assembly, inverter P.C. board

- (1) Remove the cabinet and panels. (Refer to 1.)
- (2) Disconnect the lead wire to the reactor and the following connectors;
<Inverter P.C. board>
CN721 (R.V.coil)
CN722 (Defrost heater)
CN932 (Fan motor)
CN641 (Defrost thermistor and discharge temperature thermistor)
CN643 (Ambient temperature thermistor)
CN644 (Outdoor heat exchanger temperature thermistor)
CN724 (LEV)
- (3) Remove the compressor connector (CN61).
- (4) Remove the screws fixing the relay panel. (See Photo 3.)
- (5) Remove the inverter assembly. (See Photo 4.)
- (6) Remove the screw of the earth wire and screw of the T.B.support. (See Photo 4.)
- (7) Remove the inverter P.C. board from the inverter assembly.

3. Removing R.V. coil

- (1) Remove the cabinet and panels. (Refer to 1.)
- (2) Remove the R.V. coil. (See Photo 5.)

4. Removing the discharge temperature thermistor, defrost thermistor and outdoor heat exchanger temperature thermistor.

- (1) Remove the cabinet and panels. (Refer to 1.)
- (2) Pull out the discharge temperature thermistor from its holder. (See Photo 5.)
- (3) Pull out the defrost thermistor from its holder. (See Photo 6.)
- (4) Pull out the outdoor heat exchanger temperature thermistor from its holder. (See Photo 6.)

PHOTOS

Photo 3

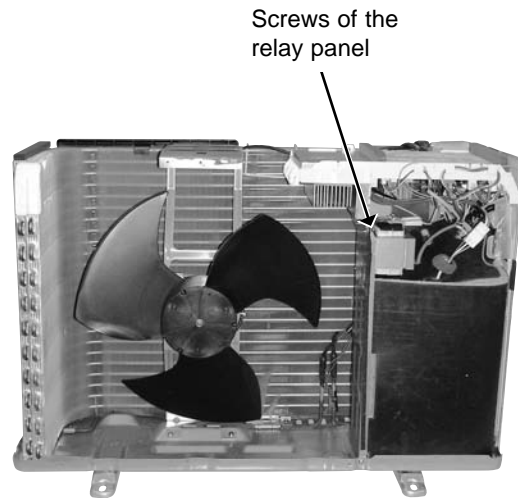

Photo 4 (inverter assembly)

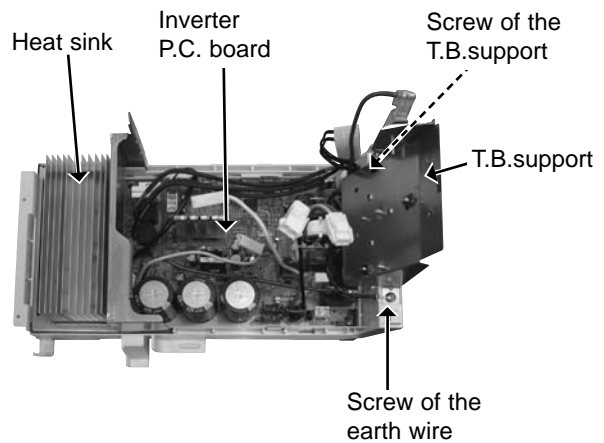

Photo 5



OPERATING PROCEDURE

5. Removing outdoor fan motor

- (1) Remove the cabinet and panels. (Refer to 1.)
- (2) Disconnect the connectors for outdoor fan motor.
- (3) Remove the propeller nut. (See Photo 7.)
- (4) Remove the propeller. (See Photo 7.)
- (5) Remove the screws fixing the fan motor. (See Photo 7.)
- (6) Remove the fan motor.

6. Removing the compressor and 4-way valve

- (1) Remove the cabinet and panels. (Refer to 1.)
- (2) Remove the inverter assembly. (Refer to 2.)
- (3) Recover gas from the refrigerant circuit.
NOTE: Recover gas from the pipes until the pressure gauge shows 0 kg/cm² (0 MPa).
- (4) Detach the welded part of the suction and the discharge pipe connected with compressor.
- (5) Remove the nuts of compressor legs.
- (6) Remove the compressor.
- (7) Detach the welded part of pipes connected with 4-way valve. (See Photo 8.)

PHOTOS

Photo 6

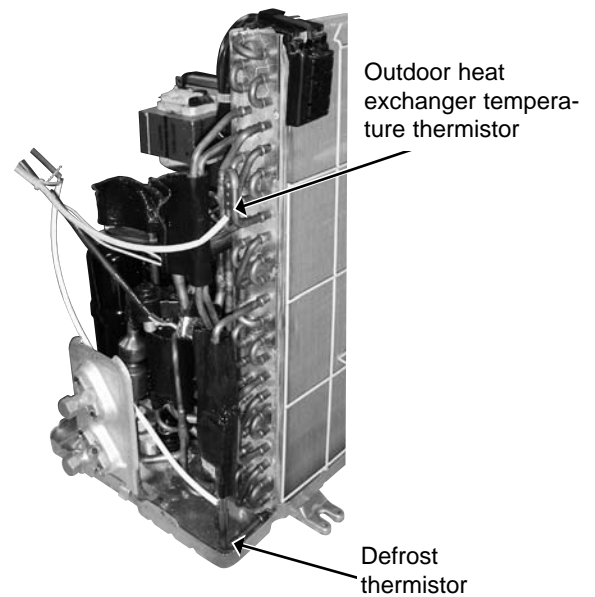

Photo 7

Screws of the outdoor fan motor

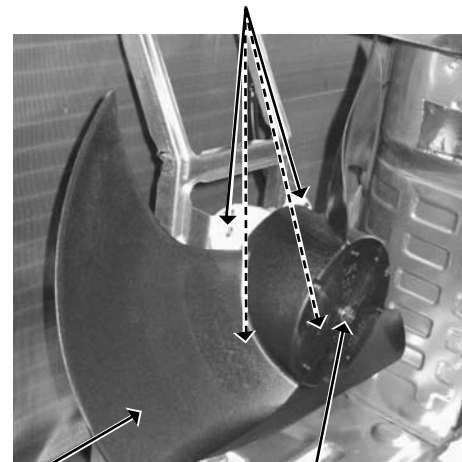

Photo 8





HEAD OFFICE: TOKYO BLDG., 2-7-3, MARUNOUCHI, CHIYODA-KU, TOKYO 100-8310, JAPAN

© Copyright 2007 MITSUBISHI ELECTRIC ENGINEERING CO.,LTD
Distributed in Oct. 2007. No. OBH489 REVISED EDITION-A 6
Distributed in Aug. 2007. No. OBH489 6
Made in Japan

New publication, effective Oct. 2007
Specifications subject to change without notice.