



SPLIT-TYPE, AIR CONDITIONERS
 SPLIT-TYPE, HEAT PUMP AIR CONDITIONERS

No. OB269



SERVICE MANUAL

Wireless type
 Models

MSC-C07TV	- E1 (WH)	- MU-C07TV	- E1
MSC-C09TV	- E1 (WH)	- MU-C09TV	- E1
MSC-C12TV	- E1 (WH)	- MU-C12TV	- E1

MSC-C07TV	- E1 (WH)	- MUH-C07TV	- E1
MSC-C09TV	- E1 (WH)	- MUH-C09TV	- E1
MSC-C12TV	- E1 (WH)	- MUH-C12TV	- E1

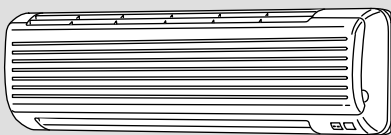

MSC-C07TV - **E1**
 MSC-C09TV - **E1**
 MSC-C12TV - **E1**



CONTENTS

1. TECHNICAL CHANGES	2
2. PART NAMES AND FUNCTIONS.....	5
3. SPECIFICATION.....	7
4. NOISE CRITERIA CURVES	9
5. OUTLINES AND DIMENSIONS.....	11
6. WIRING DIAGRAM	13
7. REFRIGERANT SYSTEM DIAGRAM	15
8. PERFORMANCE CURVES	18
9. MICROPROCESSOR CONTROL	35
10. SERVICE FUNCTIONS.....	45
11. TROUBLESHOOTING	48
12. DISASSEMBLY INSTRUCTIONS.....	59
13. PARTS LIST.....	65



1

TECHNICAL CHANGES

MSC-C07SV -[E1] → MSC-C07TV -[E1]

MSC-C09SV -[E1] → MSC-C09TV -[E1]

MSC-C12SV -[E1] → MSC-C12TV -[E1]

1. Rated voltage has changed to 230V.
2. Remote controller has changed.
 - Slide switch for setting the type has added on the remote controller.
 - Indoor units for MU type and MUH type are common specifications.
 - Set slide switch on the remote controller according to the type of outdoor unit.

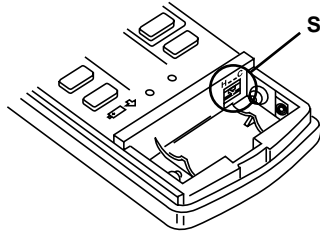

Type	COOL & HEAT	COOL ONLY
The position of the slide switch	<p>H == C</p>	<p>H == C</p>

MU-C07TV -[E1]

MU-C09TV -[E1]

MU-C12TV -[E1]

New model

MUH-C07SV -[E1] → MUH-C07TV -[E1]

1. Rated voltage has changed to 230V.
2. Path of heat exchanger has changed.
3. Refrigerant filling capacity has changed.(0.85kg → 0.90kg)
4. Capillary tube has changed.($\phi 3.0 \times \phi 1.6 \times 600 \rightarrow \phi 3.0 \times \phi 1.6 \times 750$, $\phi 3.0 \times \phi 1.4 \times 600 \rightarrow \phi 3.0 \times \phi 1.4 \times 700$)
5. Temperature of defrosting control has changed.
6. Additional refrigerant charge has been changed.(50g/m → 25g/m)

MUH-C09SV -[E1] → MUH-C09TV -[E1]

1. Rated voltage has changed to 230V.
2. Outdoor heat exchanger has changed.
3. Refrigerant filling capacity has changed.(0.80kg → 1.00kg)
4. Capillary tube has changed.
($\phi 3.0 \times \phi 1.6 \times 400 \rightarrow \phi 3.0 \times \phi 1.8 \times 400$, $\phi 3.0 \times \phi 1.4 \times 550 \rightarrow \phi 3.0 \times \phi 1.4 \times 650$, $\phi 3.0 \times \phi 1.4 \times 800 \times 2 \rightarrow \phi 3.0 \times \phi 1.4 \times 500 \times 2$)
5. Outdoor fan motor has changed.(RA6V23-EA → RA6V33-CA)
6. Temperature of defrosting control has changed.
7. Additional refrigerant charge has been changed.(50g/m → 25g/m)

MUH-C12SV -[E1] → MUH-C12TV -[E1]

1. Rated voltage has changed to 230V.
2. Path of heat exchanger has changed.
3. Refrigerant filling capacity has changed.(1.20kg → 1.25kg)
4. Capillary tube has changed.($\phi 3.0 \times \phi 1.8 \times 250$, → $\phi 3.0 \times \phi 1.8 \times 400$)
5. High pressure protection temperature has changed.
6. Temperature of defrosting control has changed.
7. Additional refrigerant charge has been changed.(50g/m → 25g/m)

INFORMATION FOR THE AIR CONDITIONER WITH R407C REFRIGERANT

This room air conditioner adopts HFC refrigerant (R407C) which will never destroy the ozone layer.

Pay attention to following points.

- ① Take sufficient care not to allow water and other contaminations to enter the R407C refrigerant during storage and installation, since it is more susceptible to contaminations than HCFC (R22) refrigerant.
- ② Clean refrigerant pipings should be used.
- ③ Composition change may occur in R407C since it is a mixed refrigerant. When charging, charge liquid refrigerant to prevent composition change.
- ④ Be especially careful when managing the tools.
If dust, dirt, or water mixes in the refrigerant cycle, it may cause decrease of performance.

		New refrigerant	Previous refrigerant
Refrigerant	Refrigerant	R407C	R22
	Composition (Ratio)	R32: R125: R134a (23%:25%:52%)	HCFC22 (100%)
	Refrigerant handling	Non-azeotropic refrigerant	Single refrigerant
	Chlorine	Not included	Included
	Safety group (ASHRAE)	A1/A1	A1
	Molecular weight	86.2	86.5
	Boiling point (°C)	-43.6	-40.8
	Steam pressure [25°C](Mpa [Gauge])	0.9177	0.94
	Saturated steam density [25°C](Kg/m ³)	42.5	44.4
	Combustibility	Non combustible	Non combustible
	ODP ※1	0	0.055
	GWP ※2	1530	1700
	Refrigerant charge method	From liquid phase in cylinder	Gas phase
Additional charge on leakage	Impossible	Possible	
Lubricant	Kind	Incompatible oil	Compatible oil
	Color	Non	Light yellow
	Smell	Non	Non

※1 :Ozone Destruction Parameter : based on CFC11

※2 :Global Warmth Parameter : based on CO₂

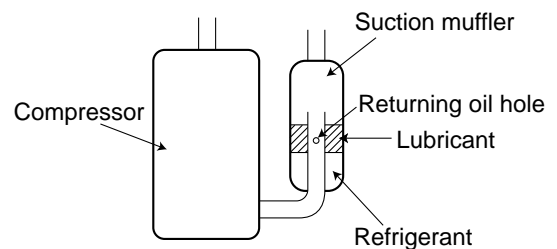
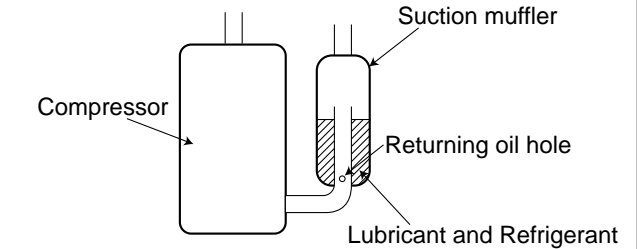
	New Specification	Previous Specification
Compressor	<p>The incompatible lubricant easily separates from refrigerant and makes the layer in the upper inside the suction muffler. The higher position of the returning oil hole enables to return the lubricant of the upper layer to the compressor.</p> 	<p>Since refrigerant and lubricant are compatible each other, lubricant returns to the compressor through the lower position returning oil hole.</p> 

Conversion chart of refrigerant temperature and pressure

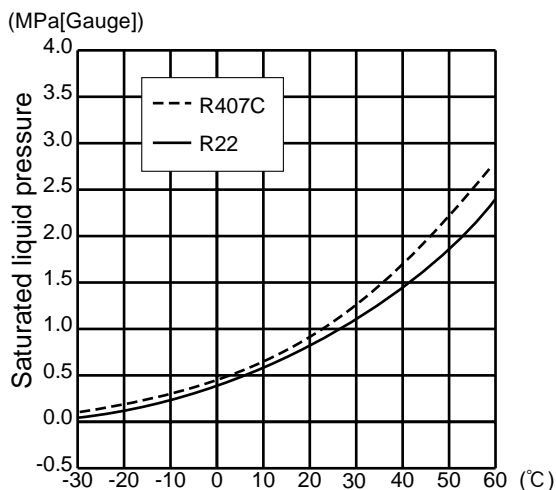

NOTE : The unit of pressure has been changed to MPa on the international system of units(SI unit system).

The conversion factor is: **1(MPa[Gauge]) =10.2(kgf/cm²[Gauge])**

1. Tools dedicated for the air conditioner with R407C refrigerant

The following tools are required for R407C refrigerant. Some R22 tools can be substituted for R407C tools. Do not use tools that are used with R22 refrigerant in order to avoid mixing oils.

R407C tools	Can R22 tools be used?	Description
Gauge manifold	No	A gauge manifold with a sight glass is recommended for charging the liquid refrigerant.
Charge hose	No	Hose material have been changed to improve the pressure resistance.
Gas leak detector	No	Dedicated for HFC refrigerant.
Torque wrench	Yes	
Flare tool	Yes	
Vacuum pump adapter	New	Provided to prevent the back flow of oil. This adapter enables you to use existing vacuum pumps.
Electronic scale for refrigerant charging	New	Use the electronic control scale for measuring the R407C.

2. Refrigerant piping

Do not use copper pipes which are broken, deformed or discoloured.

In addition, be sure that the inner surfaces of the pipes are clean, free of hazardous sulfur and oxides, or have no dust/ dirt, shaving particles, oil, moisture or any other contamination.

•If there is a large amount of residual oil inside the piping and joints, deterioration of the refrigerant oil will result.

3. Refrigerant oil

Apply the specific refrigeration oil (accessories) to the flare and the union seat surfaces.

4. Air purge

Use the vacuum pump for air purge to protect environments, and to avoid changing the composition of refrigerant.

5. Additional charge

For additional charging, charge the refrigerant with liquid phase slowly using a gas cylinder. If the refrigerant is charged with gas phase, the composition of refrigerant will change. In this case, ability of the refrigerating cycle decreases or normal operation can be impossible.

If liquid refrigerant is rapidly charged at once, the compressor may be locked.

NOTE: 1. The R407C is mixed refrigerant which consist of three different kinds of evaporative temperature. As a result, the R407C occurs the change of composition.

2. Additional refrigerant charge has been changed by change of refrigerant. (R22 → R407C)

R22 : <MU-type> 15g/m → R407C : <MU-C07/C09/C12TV> 15g/m

R22 : <MUH-type> 50g/m → R407C : <MUH-C07/C09/C12TV> 25g/m

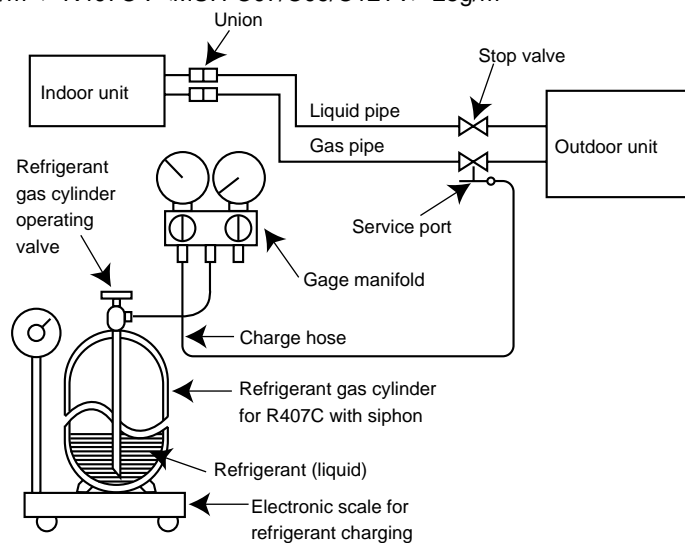

2

PART NAMES AND FUNCTIONS

INDOOR UNIT

MSC-C07TV -E1

MSC-C09TV -E1

MSC-C12TV -E1

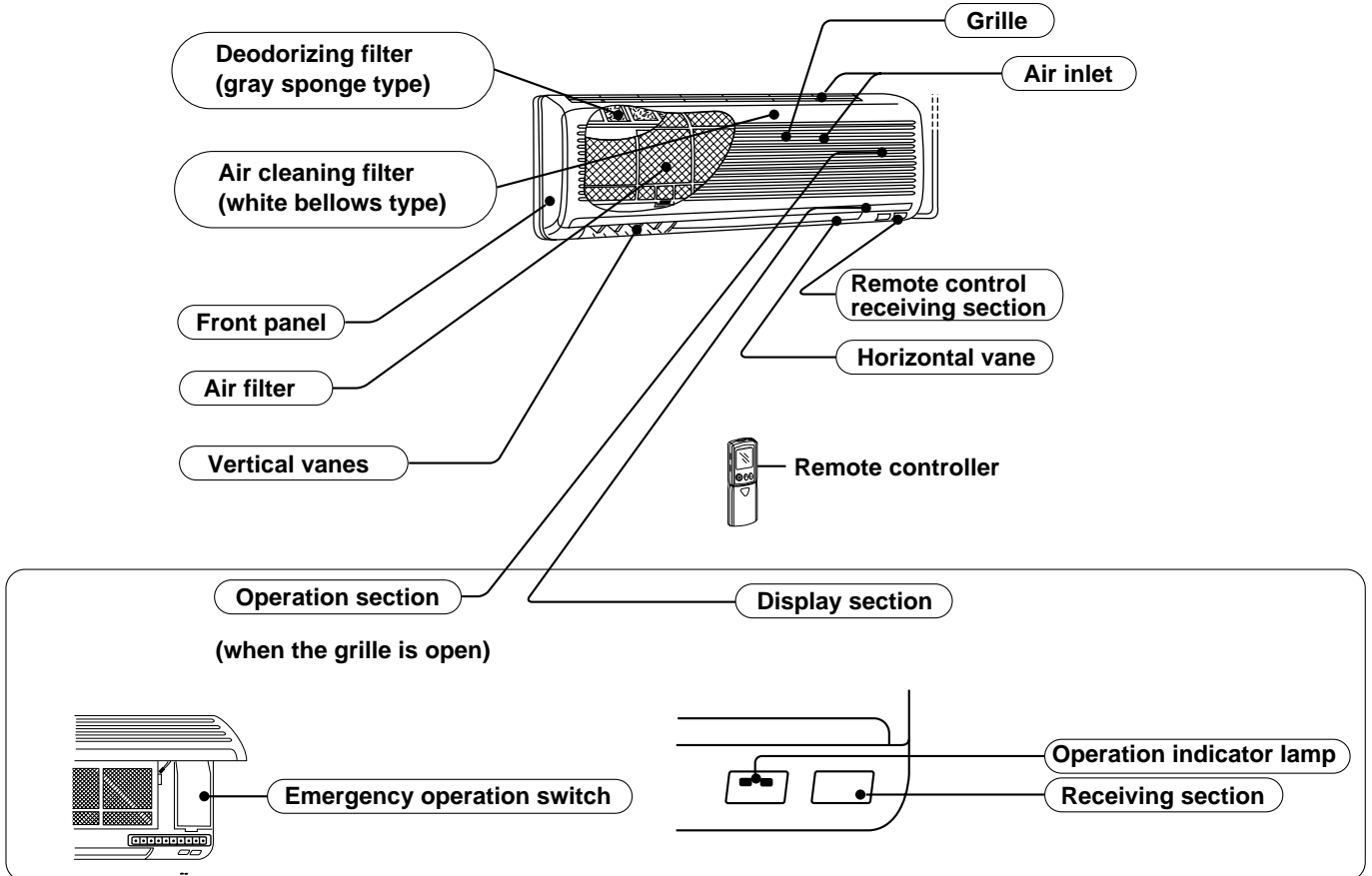

OUTDOOR UNIT

MU-C07TV -E1 MUH-C07TV -E1

MU-C09TV -E1 MUH-C09TV -E1

MU-C12TV -E1 MUH-C12TV -E1

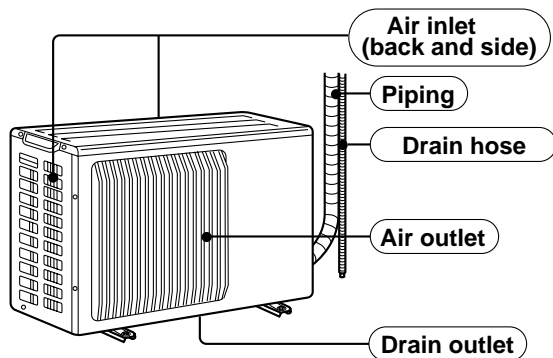

ACCESSORIES

MSC-C07TV -E1

MSC-C09TV -E1

MSC-C12TV -E1

<Indoor unit>

①	Installation plate	1
②	Installation plate fixing screw 4 x 25 mm	5
③	Remote controller mounting hardware	1
④	Fixing screw for ③ 3.5 x 16 mm (Black)	2
⑤	Battery (AAA) for remote controller	2
⑥	Wireless remote controller	1
⑦	Felt tape (Used for left or left-rear piping)	1
⑧	Deodorizing filter	1
⑨	Air cleaning filter	1
⑩	Refrigeration oil	1

MUH-C07TV -E1

MUH-C09TV -E1

MUH-C12TV -E1

<Outdoor unit : MUH type only>

⑪	Drain socket	1
⑫	Drain cap $\phi 33$	2

MSC-C07TV -E1
 MSC-C09TV -E1
 MSC-C12TV -E1

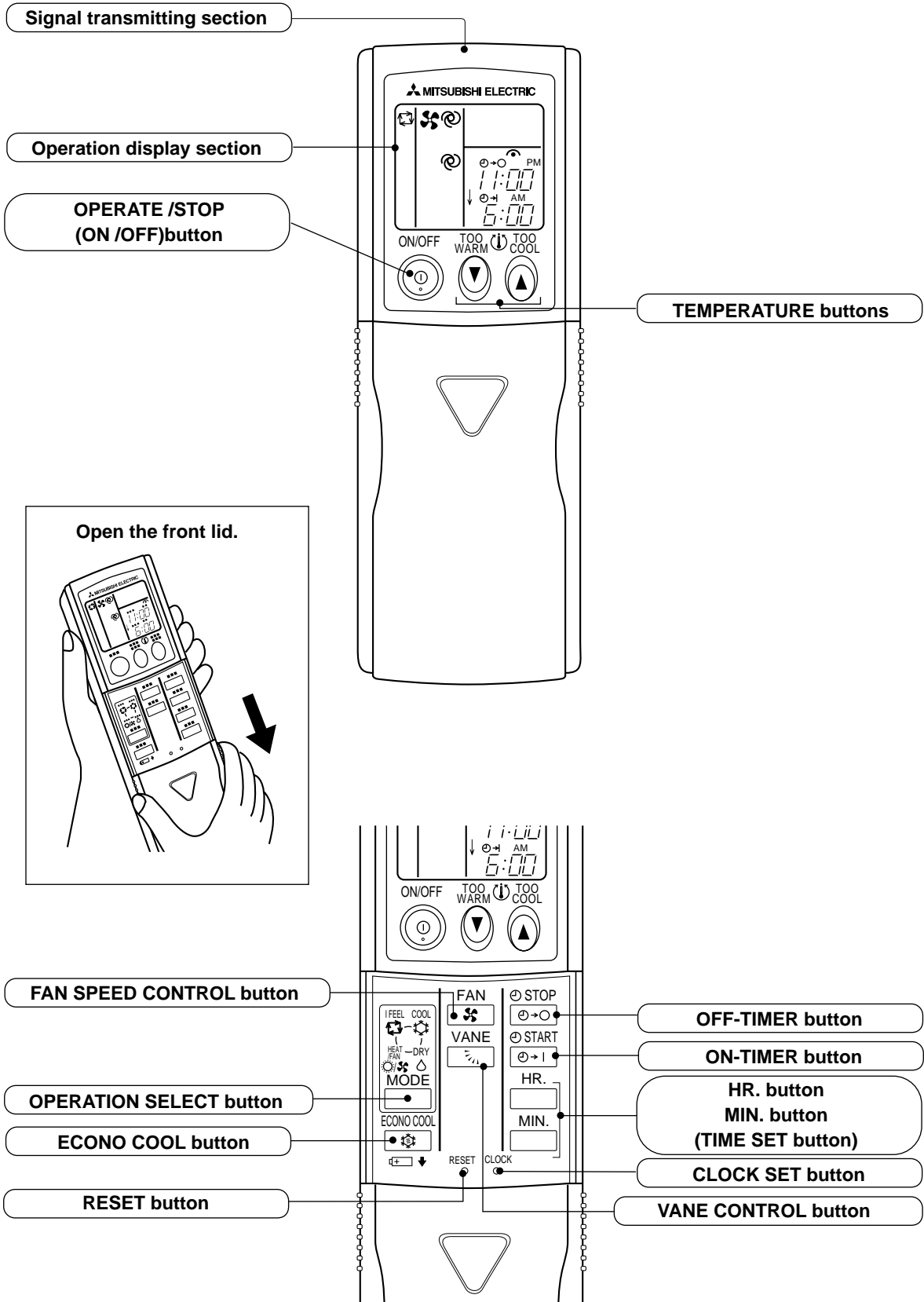

3

SPECIFICATION

Indoor model			MSC-C07TV - E1	MSC-C09TV - E1	MSC-C12TV - E1	
Function			Cooling	Cooling	Cooling	
Indoor unit power supply			Single phase 230V,50Hz	Single phase 230V,50Hz	Single phase 230V,50Hz	
Capacity	Air flow(High)	m ³ /h	474	474	588	
	Power outlet	A	10	10	10	
Electrical data	Running current	A	0.17	0.17	0.19	
	Power input	W	35	35	40	
	Power factor	%	90	90	92	
	Starting current	A	—	—	—	
	Fan motor current	A	0.17	0.17	0.19	
Fan motor	Model		RC4V19-BA	RC4V19-BA	RC4V19-BA	
	Winding resistance(at20°C)	Ω	WHT-BLK 292 BLK-RED 325	WHT-BLK 292 BLK-RED 325	WHT-BLK 292 BLK-RED 325	
Dimensions W×H×D		mm	850×278×191	850×278×191	850×278×191	
Weight		kg	9	9	10	
Air direction			5	5	5	
Special remarks	Sound level(High)	dB	36	36	39	
	Fan speed(High)	rpm	950	950	1020	
	Fan speed regulator			3	3	3
	Thermistor RT11(at25°C)	kΩ	10	10	10	
	Thermistor RT12(at25°C)	kΩ	10	10	10	
Outdoor model			MU-C07TV - E1	MU-C09TV - E1	MU-C12TV - E1	
Outdoor unit power supply			Single phase 230V,50Hz	Single phase 230V,50Hz	Single phase 230V,50Hz	
Capacity	Capacity	kW	2.25	2.5	3.55	
	Dehumidification	ℓ /h	0.8	1.0	1.6	
	Outdoor air flow	m ³ /h	1686	1686	1914	
Electrical data	Power outlet	A	10	10	10	
	Running current	A	3.03	3.53	6.01	
	Power input	W	695	795	1330	
	Auxiliary heater	A(kW)	—	—	—	
	Power factor	%	99	98	96	
	Starting current	A	18	19	34	
	Compressor motor current	A	2.75	3.25	5.64	
	Fan motor current	A	0.29	0.29	0.37	
Coefficient of performance(C.O.P)			3.08	3.01	2.59	
Compressor	Model		RE-130VGSHT	RE-145VGSHT	RE-231VHSHT	
	Output	W	650	700	1100	
	Winding resistance(at20°C)	Ω	C-R 4.18 C-S 5.76	C-R 4.03 C-S 5.71	C-R 2.25 C-S 4.07	
Fan motor	Model		RA6V23-EB	RA6V23-EB	RA6V33-CB	
	Winding resistance(at20°C)	Ω	WHT-BLK 258 BLK-RED 385	WHT-BLK 258 BLK-RED 385	WHT-BLK 176 BLK-RED 413	
Dimensions W×H×D		mm	780×540×255	780×540×255	780×540×255	
Weight		kg	32	32	34	
Special remarks	Sound level	dB	45	45	49	
	Fan speed	rpm	645	645	725	
	Fan speed regulator			1	1	1
	Refrigerant filling capacity(R407C)	kg	0.77	0.88	0.90	
	Refrigerating oil (Model)	cc	350 (NEO22)	350 (NEO22)	620 (NEO22)	

NOTE: Test conditions are based on JIS C 9612.

Cooling : Indoor DB27°C / WB19°C

Outdoor DB35°C / WB24°C



Indoor model			MSC-C07TV - E1		MSC-C09TV - E1		MSC-C12TV - E1	
Function			Cooling	Heating	Cooling	Heating	Cooling	Heating
Indoor unit power supply			Single phase 230V,50Hz		Single phase 230V,50Hz		Single phase 230V,50Hz	
Capacity	Air flow(High)	m³ /h	474	504	474	504	588	576
Electrical data	Power outlet	A	10		10		10	
	Running current	A	0.17		0.17		0.19	
	Power input	W	35		35		40	
	Power factor	%	90		90		92	
	Starting current	A	—		—		—	
	Fan motor current	A	0.17		0.17		0.19	
Fan motor	Model		RC4V19-BA		RC4V19-BA		RC4V19-BA	
	Winding resistance(at20°C)	Ω	WHT-BLK 292 BLK-RED 325		WHT-BLK 292 BLK-RED 325		WHT-BLK 292 BLK-RED 325	
	Dimensions W×H×D	mm	850×278×191		850×278×191		850×278×191	
	Weight	kg	9		9		10	
	Air direction		5		5		5	
Special remarks	Sound level(High)	dB	36	35	36	35	39	39
	Fan speed(High)	rpm	950	1000	950	1000	1020	1000
	Fan speed regulator		3		3		3	
	Thermistor RT11(at25°C)	kΩ	10		10		10	
	Thermistor RT12(at25°C)	kΩ	10		10		10	
Outdoor model			MUH-C07TV - E1		MUH-C09TV - E1		MUH-C12TV - E1	
Outdoor unit power supply			Single phase 230V,50Hz		Single phase 230V,50Hz		Single phase 230V,50Hz	
Capacity	Capacity	kW	2.2	2.5	2.55	3.2	3.45	4.2
	Dehumidification	ℓ /h	0.7	—	1.0	—	1.5	—
	Outdoor air flow	m³ /h	1686		1914		1914	
Electrical data	Power outlet	A	10		10		10	
	Running current	A	3.23	2.93	3.83	4.13	5.71	6.01
	Power input	W	735	675	875	925	1240	1310
	Auxiliary heater	A(kW)	—		—		—	
	Power factor	%	99		99	97	94	95
	Starting current	A	18		22		34	
	Compressor motor current	A	2.95	2.65	3.46	3.76	5.34	5.64
	Fan motor current	A	0.29		0.37		0.37	
Coefficient of performance(C.O.P)			2.86	3.52	2.80	3.33	2.70	3.11
Compressor	Model		RE-135VGSHT		RE-174VGSHT		RE-231VHSHT	
	Output	W	650		800		1100	
	Winding resistance(at20°C)	Ω	C-R 4.18 C-S 5.76		C-R 3.30 C-S 5.80		C-R 2.25 C-S 4.07	
Fan motor	Model		RA6V23-EA		RA6V33-CA		RA6V33-CA	
	Winding resistance(at20°C)	Ω	WHT-BLK 258 BLK-RED 385		WHT-BLK 176 BLK-RED 413		WHT-BLK 176 BLK-RED 413	
	Dimensions W×H×D	mm	780×540×255		780×540×255		780×540×255	
	Weight	kg	34		36		39	
Special remarks	Sound level	dB	47		49		49	
	Fan speed	rpm	645		720		720	
	Fan speed regulator		1		1		1	
	Refrigerant filling capacity(R407C)	kg	0.90		1.00		1.25	
	Refrigerating oil (Model)	cc	350 (NEO22)		350 (NEO22)		620 (NEO22)	
	Thermistor RT61(at0°C)	kΩ	33.18		33.18		33.18	

NOTE: Test conditions are based on JIS C 9612.

Cooling : Indoor DB27°C / WB19°C
Outdoor DB35°C / WB24°C

Heating : Indoor DB20°C
Outdoor DB 7°C / WB 6°C

4

NOISE CRITERIA CURVES

MSC-C07TV - [E1]

MSC-C09TV - [E1]

NOTCH	SPL(dB(A))	LINE
High	36	●—●

Test conditions,
Cooling : Dry-bulb temperature 27°C Wet-bulb temperature 19°C
Heating : Dry-bulb temperature 20°C

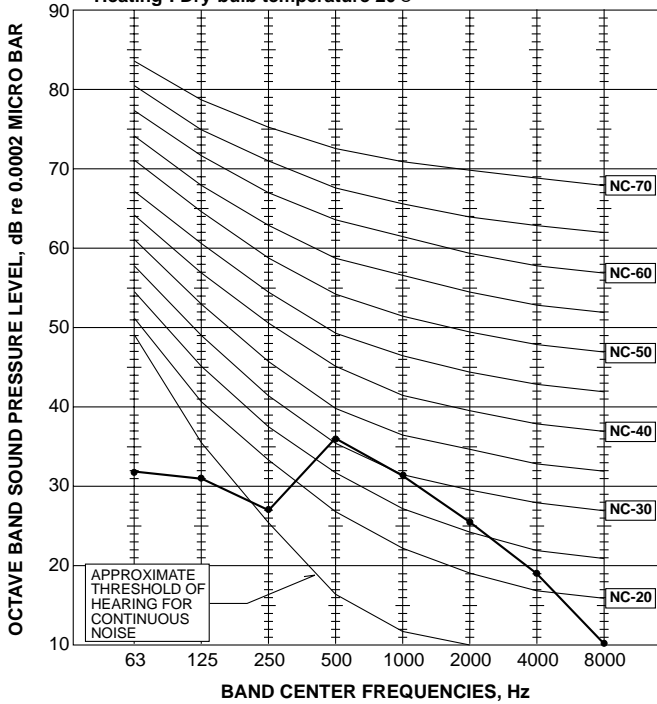

MSC-C12TV - [E1]

NOTCH	SPL(dB(A))	LINE
High	39	●—●

Test conditions,
Cooling : Dry-bulb temperature 27°C Wet-bulb temperature 19°C
Heating : Dry-bulb temperature 20°C

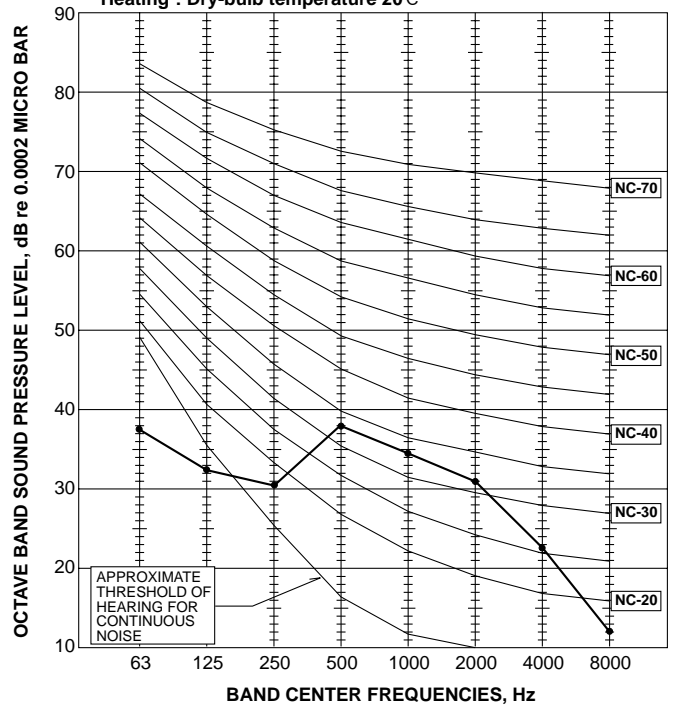

MU-C07TV - [E1]

MU-C09TV - [E1]

NOTCH	SPL(dB(A))	LINE
High	45	●—●

Test conditions,
Cooling : Dry-bulb temperature 35°C Wet-bulb temperature 24°C

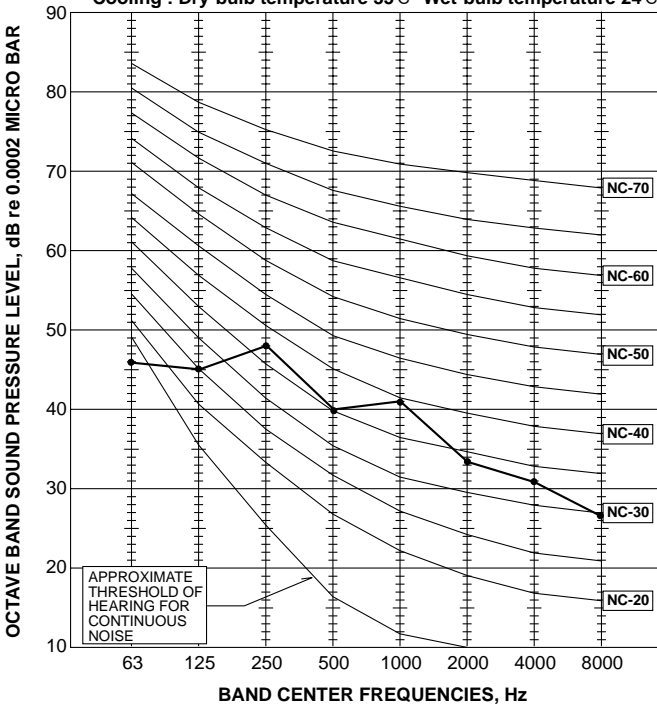

MU-C12TV - [E1]

NOTCH	SPL(dB(A))	LINE
High	49	●—●

Test conditions,
Cooling : Dry-bulb temperature 35°C Wet-bulb temperature 24°C

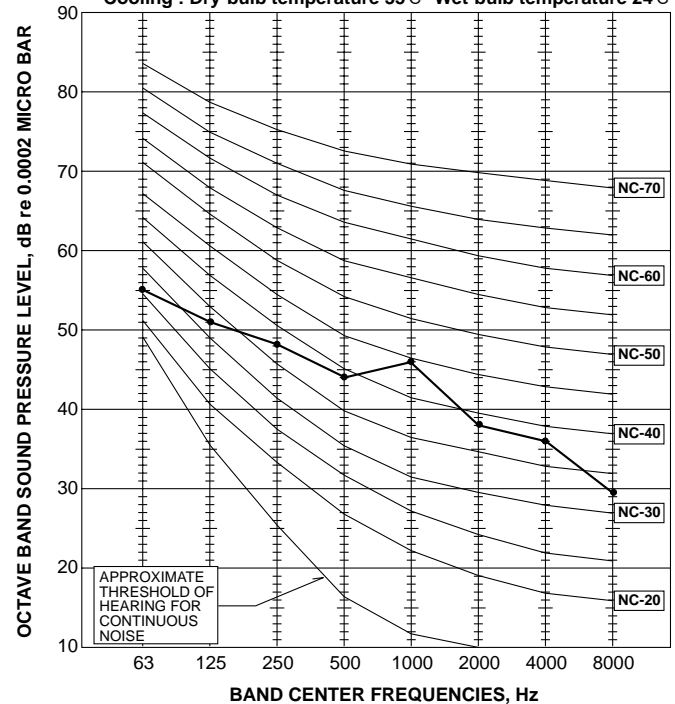

MUH-C07TV -E1

NOTCH	SPL(dB(A))	LINE
High	47	● — ●

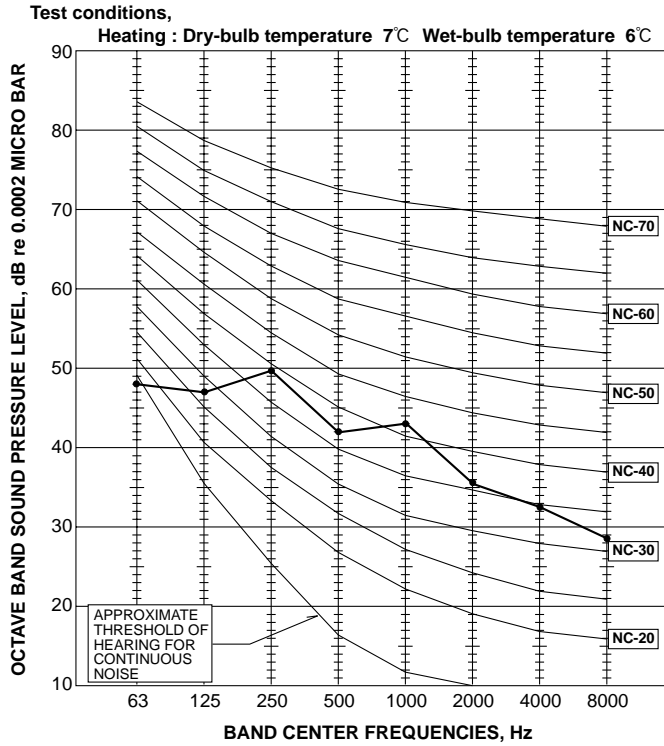

MUH-C12TV -E1

NOTCH	SPL(dB(A))	LINE
High	49	● — ●

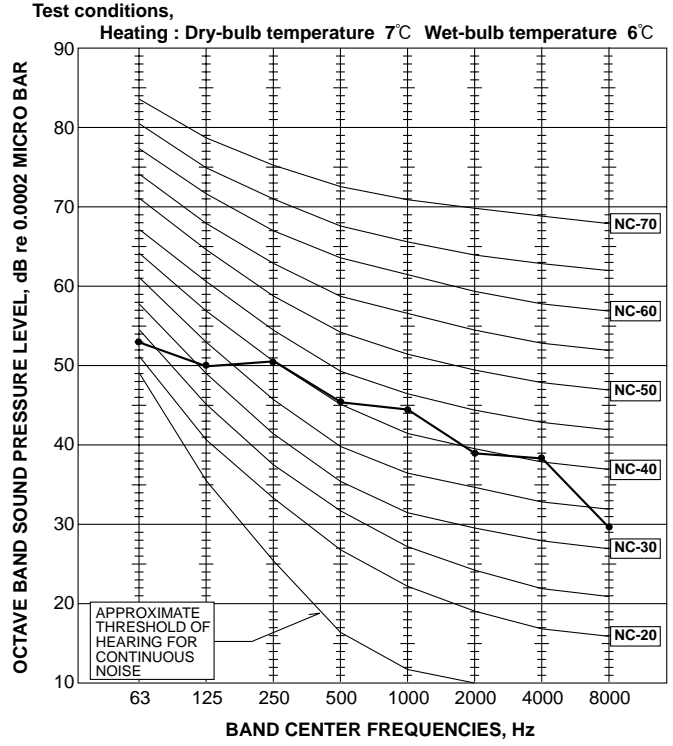

MUH-C09TV -E1

NOTCH	SPL(dB(A))	LINE
High	49	● — ●

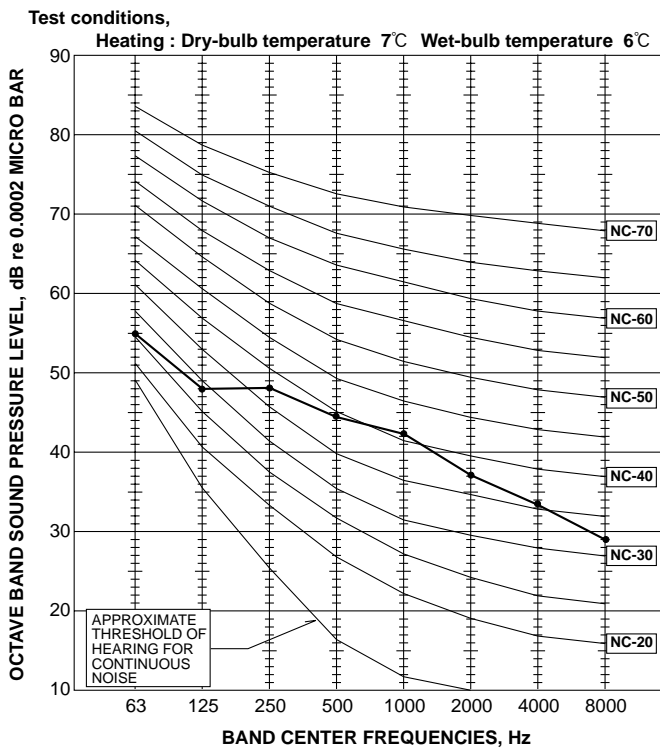

5

OUTLINES AND DIMENSIONS

Unit: mm

MSC-C07TV - [E1]

MSC-C09TV - [E1]

INDOOR UNIT

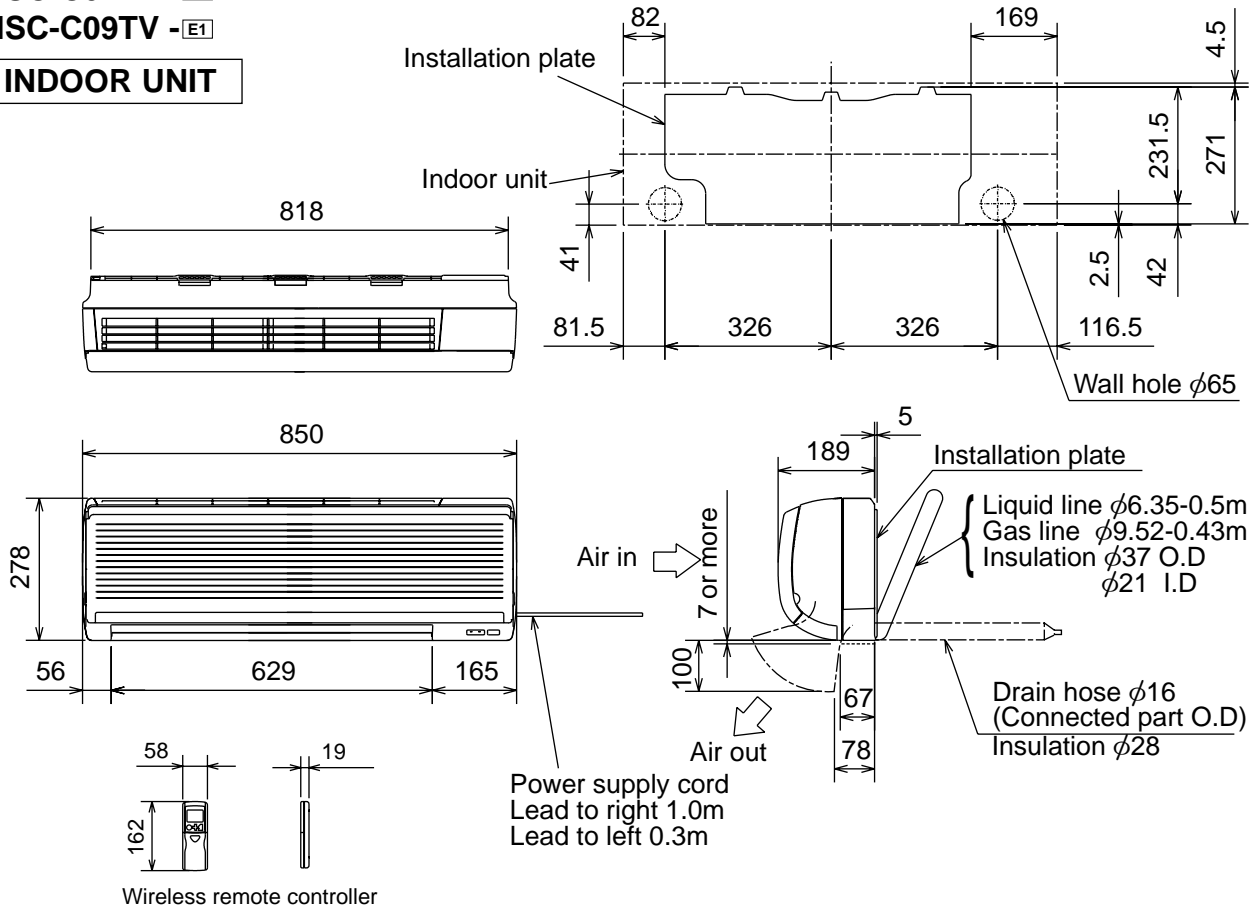

MSC-C12TV - [E1]

INDOOR UNIT

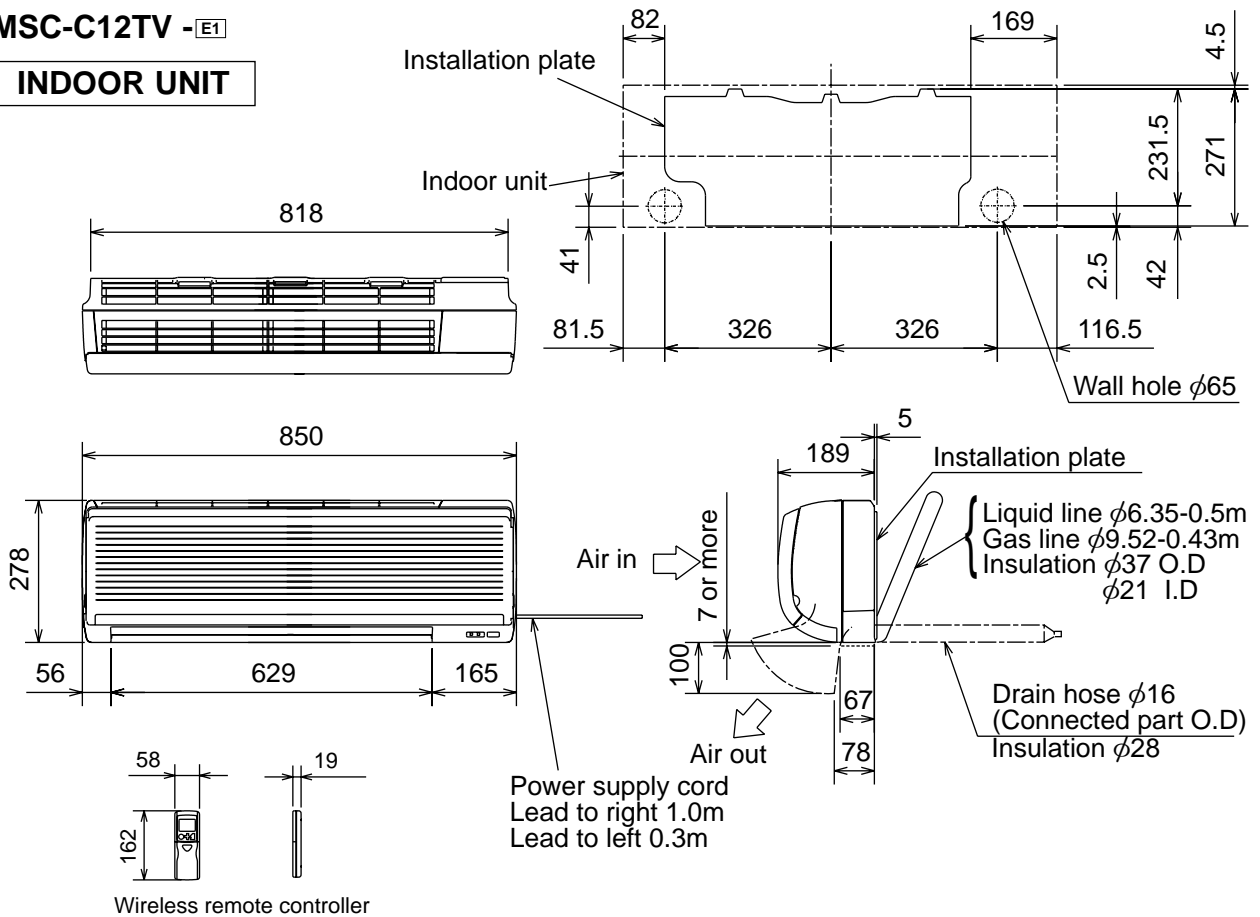

Unit: mm

MU-C07TV -E1 MUH-C07TV -E1

MU-C09TV -E1 MUH-C09TV -E1

MU-C12TV -E1 MUH-C12TV -E1

OUTDOOR UNIT

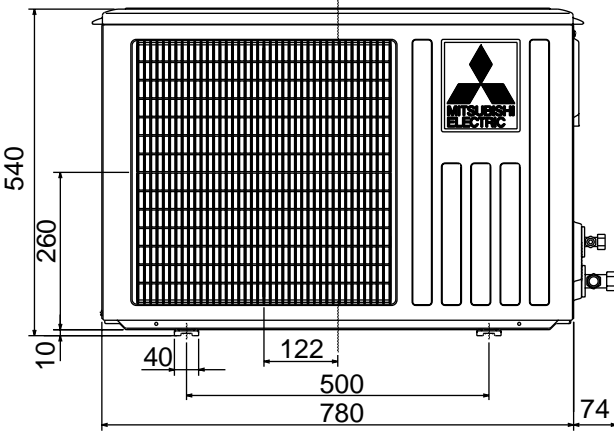
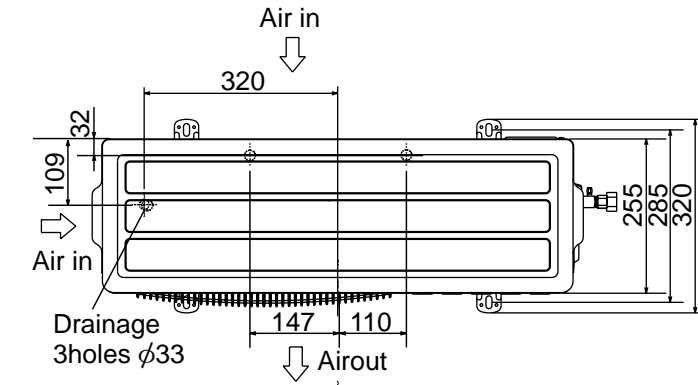

REQUIRED SPACE

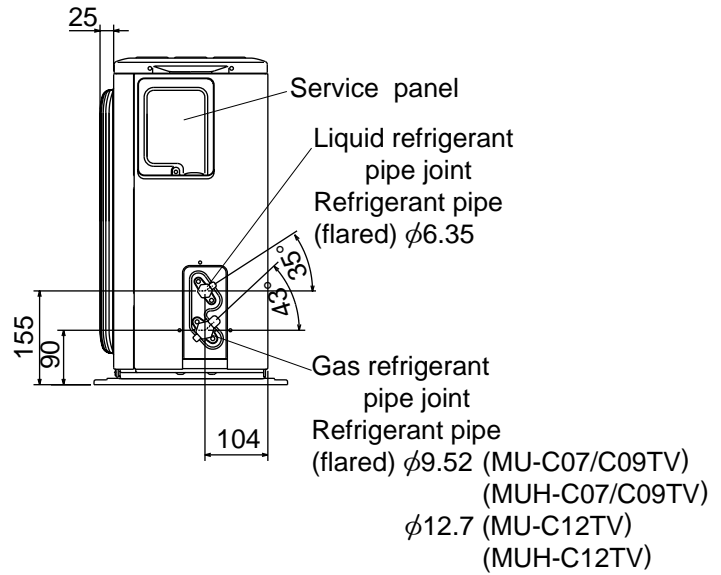
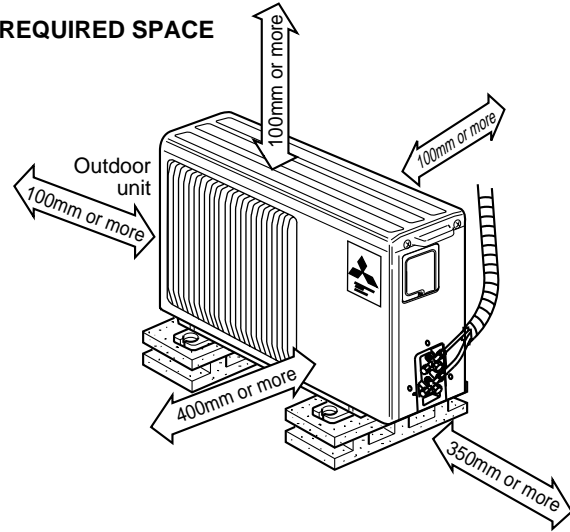

6

WIRING DIAGRAM

MSC-C07TV -E1

MSC-C09TV -E1

MSC-C12TV -E1

MODELS WIRING DIAGRAM

INDOOR UNIT

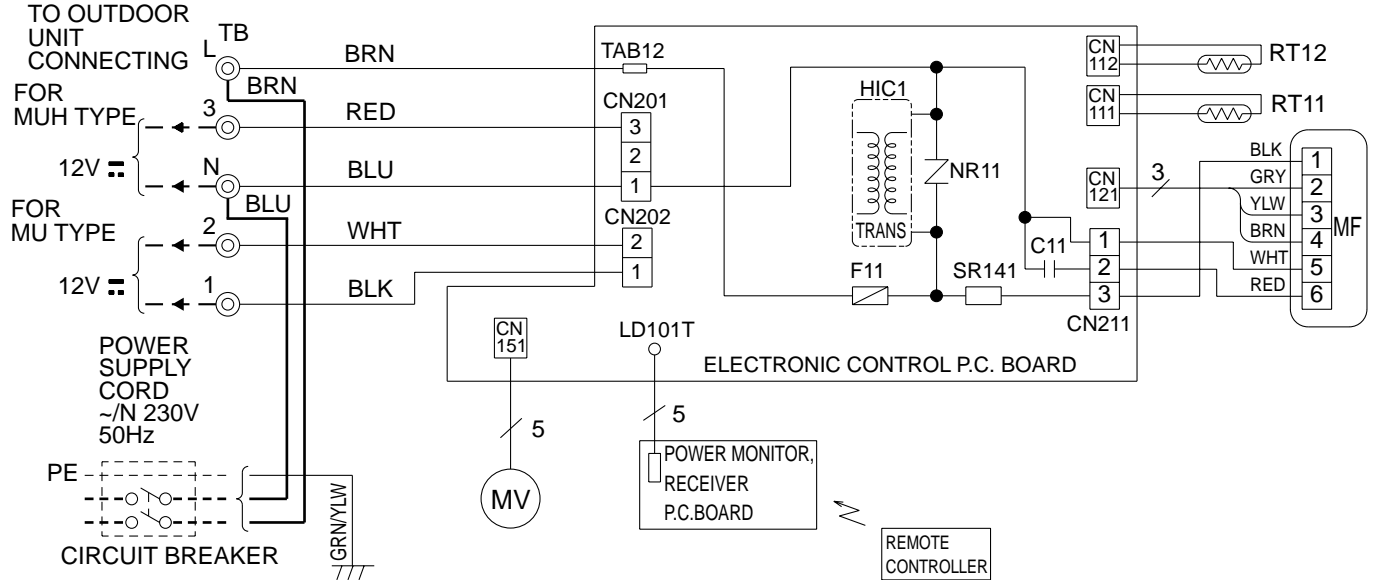

SYMBOL	NAME	SYMBOL	NAME	SYMBOL	NAME
C11	INDOOR FAN CAPACITOR	MV	VANE MOTOR	SR141	SOLID STATE RELAY
F11	FUSE(3.15A)	NR11	VARISTOR	TB	TERMINAL BLOCK
HIC1	DC/DC CONVERTER	RT11	ROOM TEMPERATURE THERMISTOR		
MF	INDOOR FAN MOTOR(INNER FUSE)	RT12	INDOOR COIL THERMISTOR		

NOTE:1. About the outdoor side electric wiring refer to the outdoor unit electric wiring diagram for servicing.
 2. Use copper conductors only. (For field wiring)
 3. Symbols below indicate.
 ○: Terminal block, □□□□ Connector

SG79J047H01

MU-C07TV -E1

MU-C09TV -E1

MU-C12TV -E1

MODELS WIRING DIAGRAM

OUTDOOR UNIT

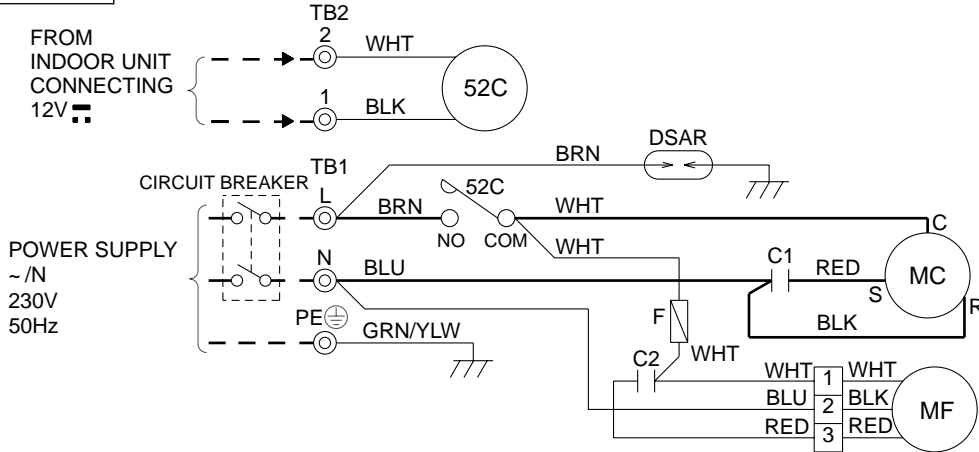

SYMBOL	NAME	SYMBOL	NAME	SYMBOL	NAME
C1	COMPRESSOR CAPACITOR	F	FUSE(2A)	TB1,TB2	TERMINAL BLOCK
C2	OUTDOOR FAN CAPACITOR	MC	COMPRESSOR(INNER PROTECTOR)	52C	CONTACTOR
DSAR	SURGE ABSORBER	MF	OUTDOOR FAN MOTOR(INNER PROTECTOR)		

NOTE:1. About the indoor side electric wiring refer to the indoor unit electric wiring diagram for servicing.

2. Use copper conductors only. (For field wiring)

3. Symbols below indicate.

⊙: Terminal block, □□□□: Connector

VG79B057H01

MUH-C07TV -E1

MUH-C09TV -E1

MUH-C12TV -E1

MODELS WIRING DIAGRAM

OUTDOOR UNIT

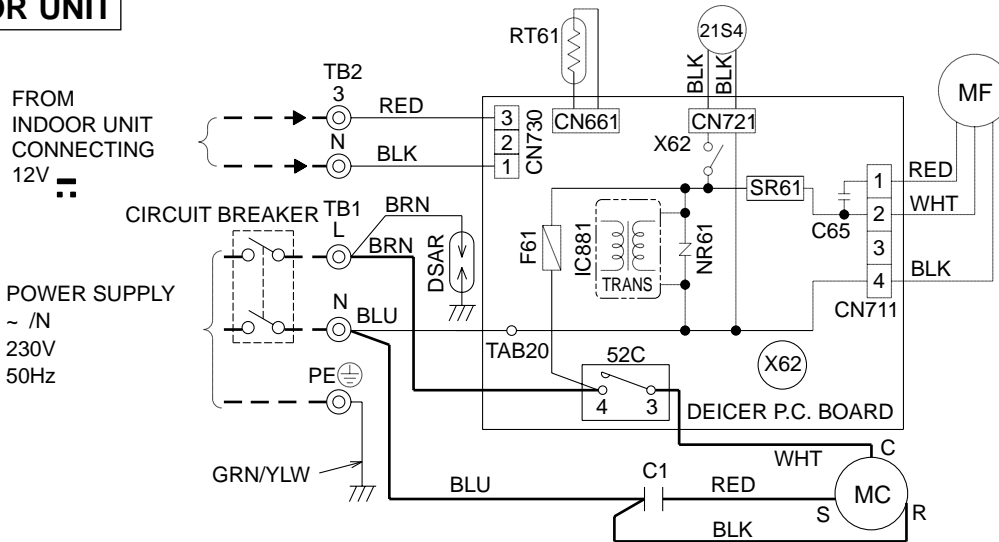

SYMBOL	NAME	SYMBOL	NAME	SYMBOL	NAME
C1	COMPRESSOR CAPACITOR	MC	COMPRESSOR(INNER PROTECTOR)	TB1,TB2	TERMINAL BLOCK
C65	OUTDOOR FAN CAPACITOR	MF	OUTDOOR FAN MOTOR(INNER PROTECTOR)	X62	R.V. COIL RELAY
DSAR	SURGE ABSORBER	NR61	VARIATOR	21S4	R.V. COIL
F61	FUSE(2A)	RT61	DEFROST THERMISTOR	52C	CONTACTOR
IC881	DC/DC CONVERTER	SR61	SOLID STATE RELAY		

NOTE:1. About the indoor side electric wiring refer to the indoor unit electric wiring diagram for servicing.

2. Use copper conductors only. (For field wiring)

3. Symbols below indicate.

⊙: Terminal block, □□□□: Connector

VG79B058H01

7

REFRIGERANT SYSTEM DIAGRAM

Unit:mm

MSC-C07TV -E1

MSC-C09TV -E1

MU-C07TV -E1

MU-C09TV -E1

INDOOR UNIT

OUTDOOR UNIT

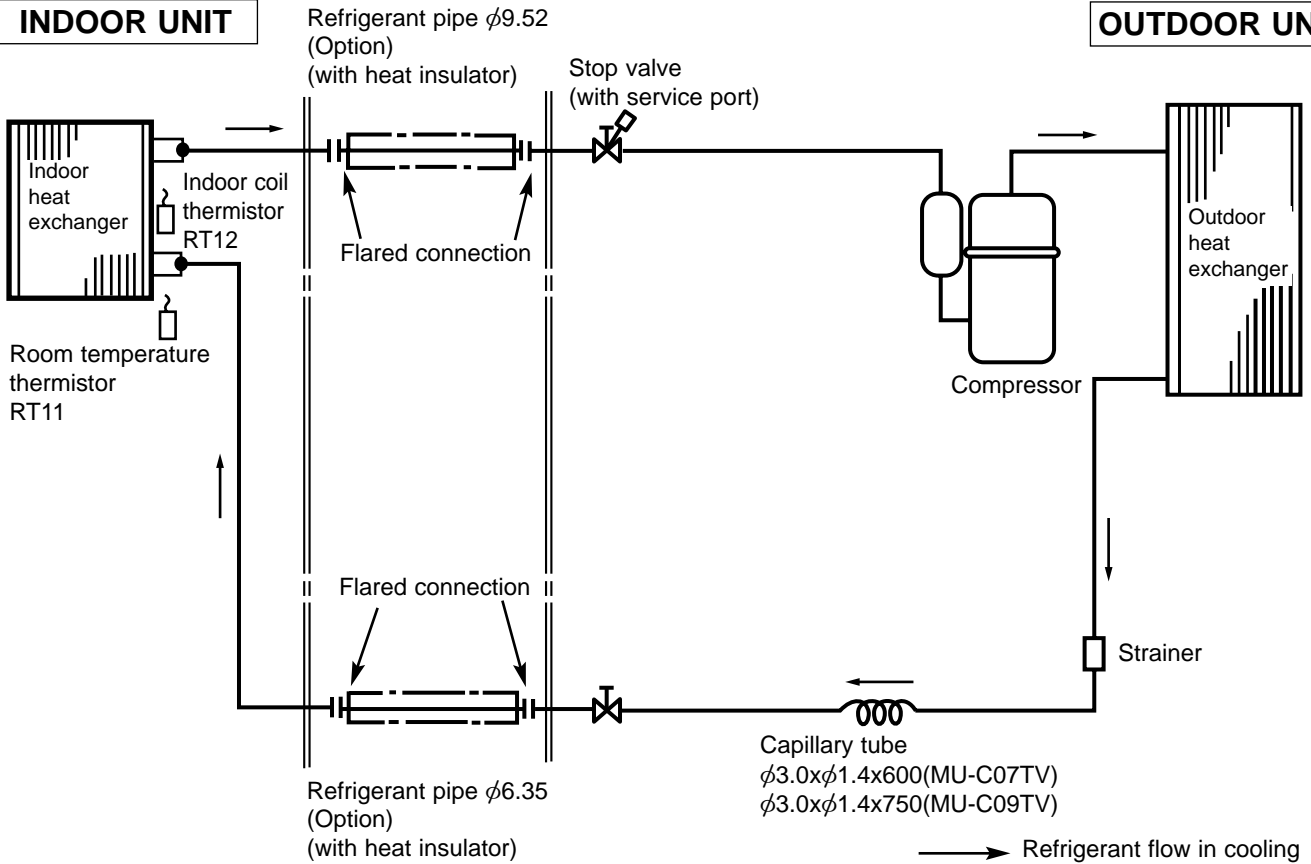

Unit:mm

MSC-C12TV -E1

INDOOR UNIT

MU-C12TV -E1

OUTDOOR UNIT

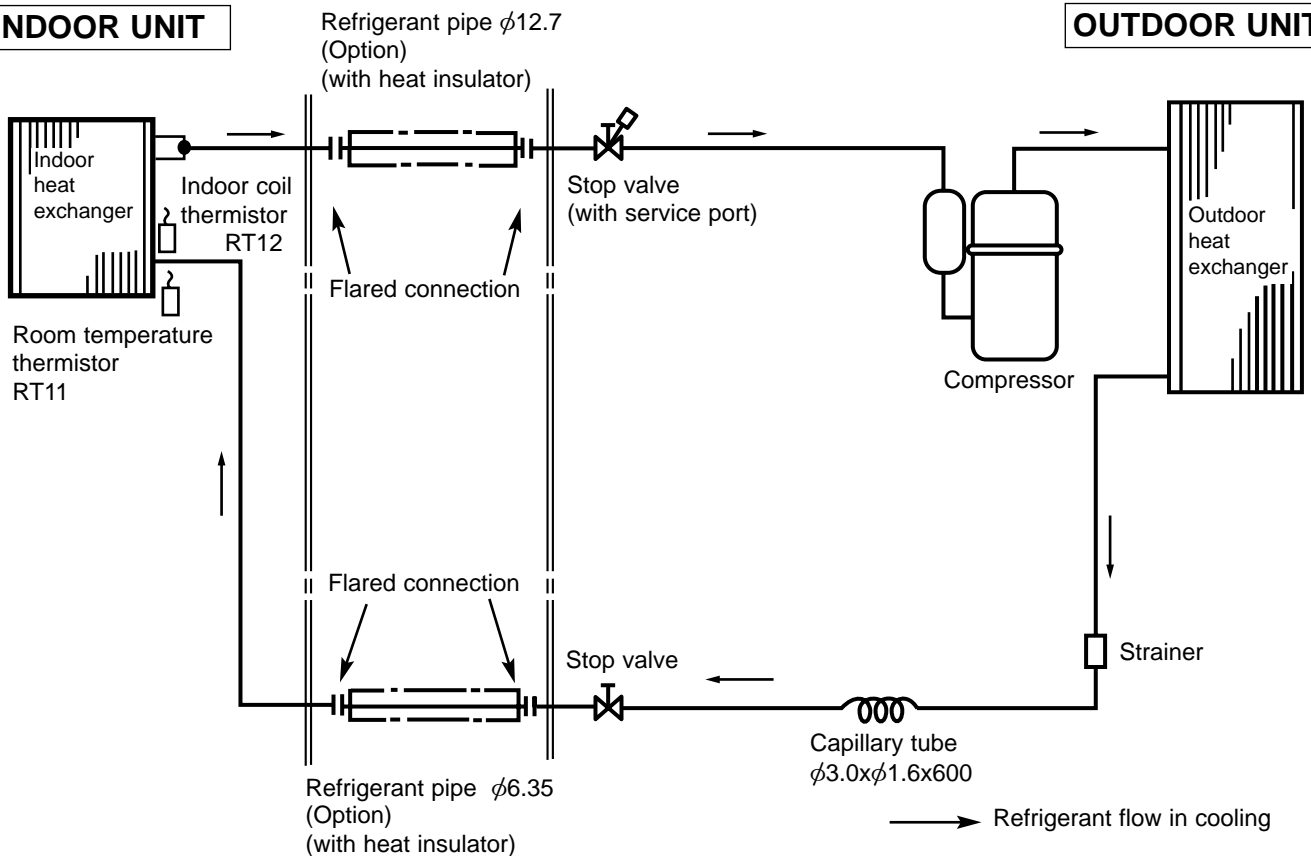

MSC-C07TV -[E1]
MSC-C09TV -[E1]

Unit:mm
MUH-C07TV -[E1]
MUH-C09TV -[E1]

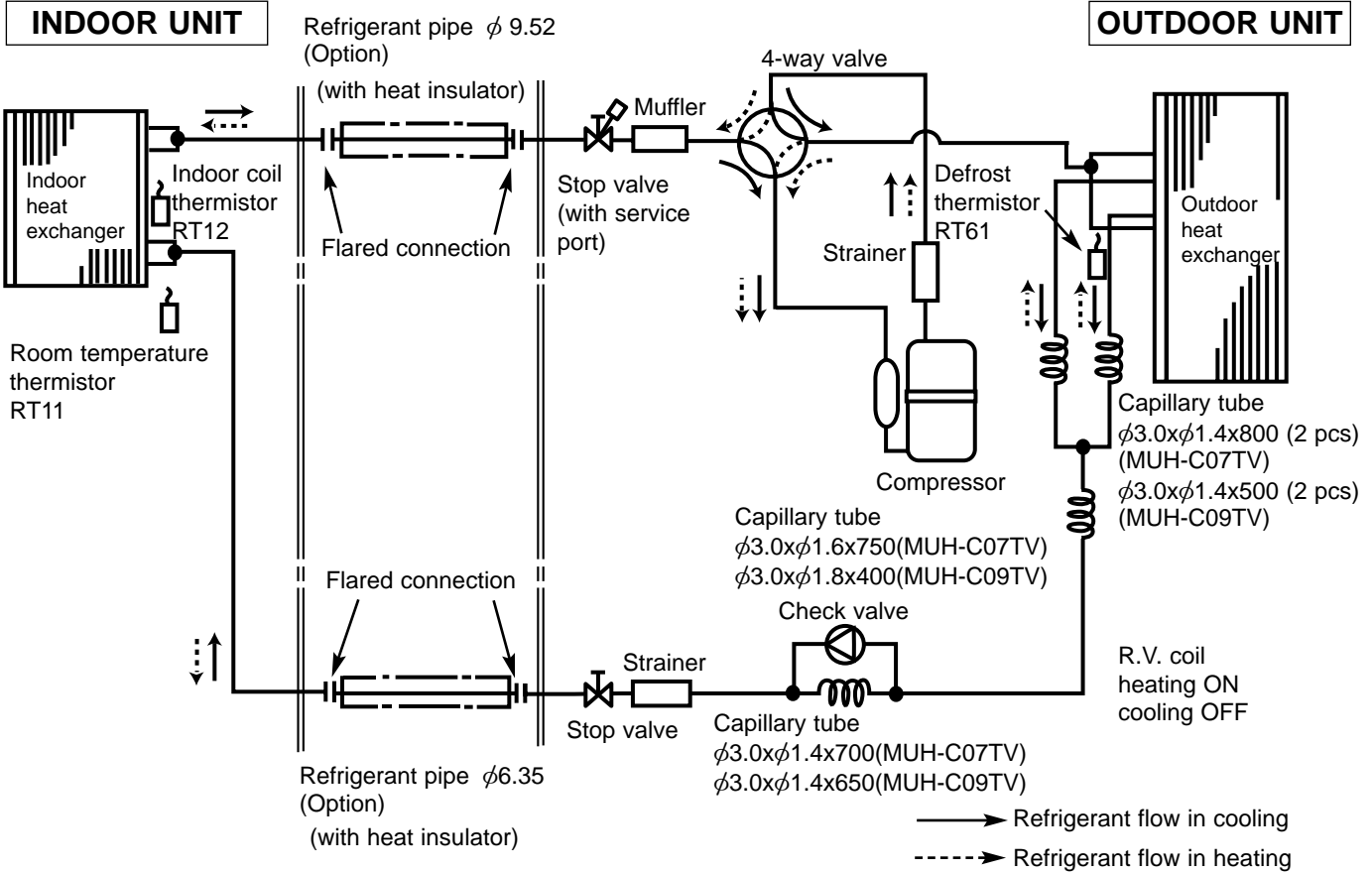

MSC-C12TV -[E1]

Unit:mm
MUH-C12TV -[E1]

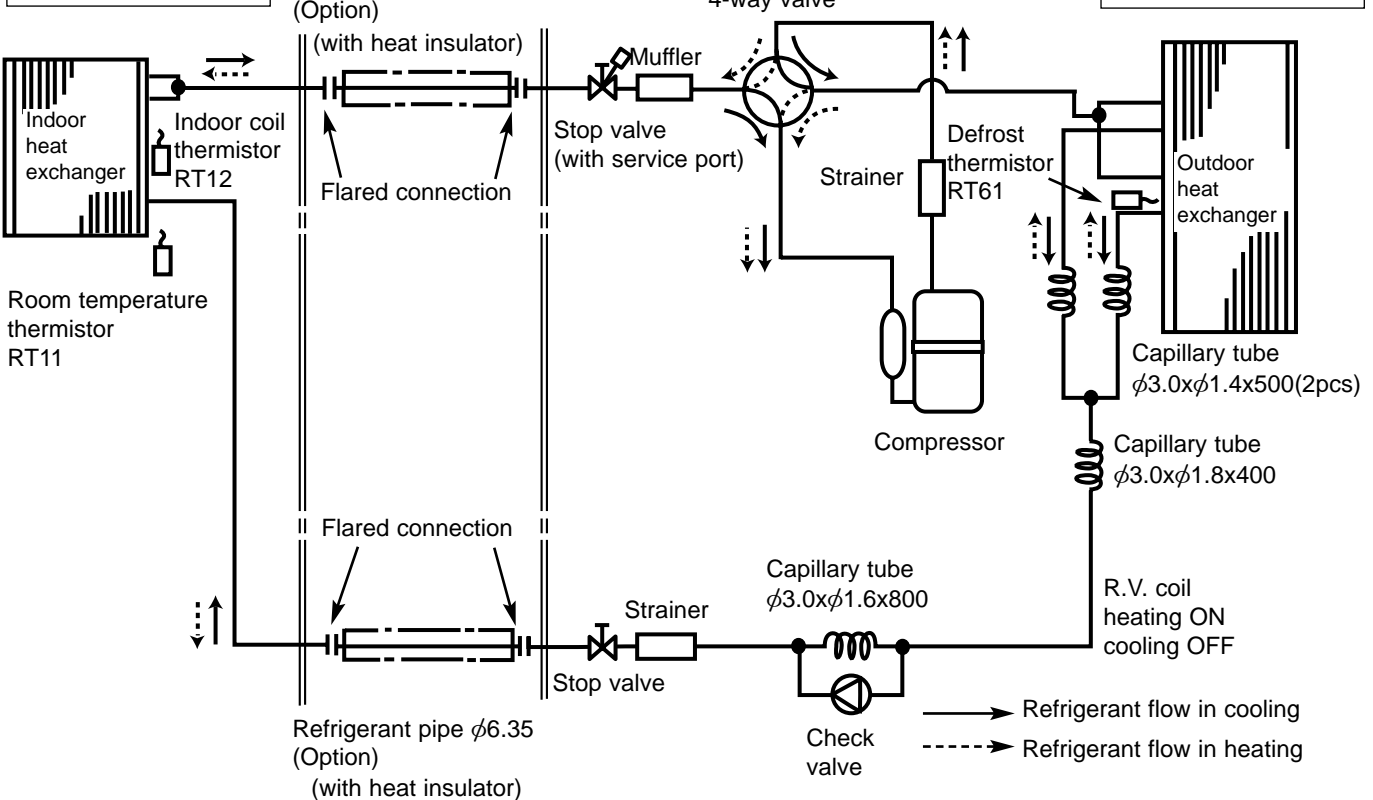

MAX. REFRIGERANT PIPING LENGTH

Model	Refrigerant piping Max. length : m A	Piping size O.D : mm		Length of connecting pipe : m	
		Gas	Liquid	Indoor unit	Outdoor unit
{ MSC-C07TV - E1 MU-C07TV - E1 { MSC-C09TV - E1 MU-C09TV - E1	10	9.52	6.35	Gas 0.43	Gas 0
				Liquid 0.5	Liquid 0
{ MSC-C12TV - E1 MU-C12TV - E1	15	12.7			

Model	Refrigerant piping Max. length : m A	Piping size O.D : mm		Length of connecting pipe : m	
		Gas	Liquid	Indoor unit	Outdoor unit
{ MSC-C07TV - E1 MUH-C07TV - E1 { MSC-C09TV - E1 MUH-C09TV - E1	10	9.52	6.35	Gas 0.43	Gas 0
				Liquid 0.5	Liquid 0
{ MSC-C12TV - E1 MUH-C12TV - E1	15	12.7			

MAX. HEIGHT DIFFERENCE

※ Height difference should be within 5m regardless of which unit, indoor or outdoor position is high.

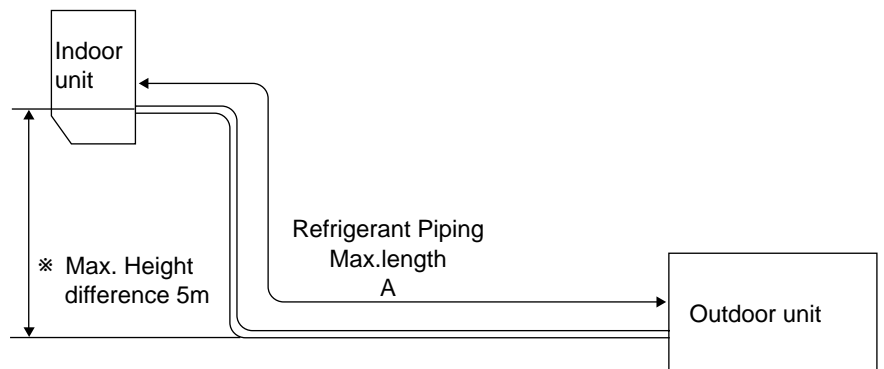

ADDITIONAL REFRIGERANT CHARGE(R407C : g)

Model	Outdoor unit precharged	Refrigerant piping length (one way)		
		7m	10m	15m
{ MSC-C07TV - E1 MU-C07TV - E1	770	0	45	/
	{ MSC-C09TV - E1 MU-C09TV - E1			
{ MSC-C12TV - E1 MU-C12TV - E1				900

Calculation : $X_g = 15\text{g/m} \times (\text{Refrigerant piping length (m)} - 7)$

Model	Outdoor unit precharged	Refrigerant piping length (one way)		
		7m	10m	15m
{ MSC-C07TV - E1 MUH-C07TV - E1	900	0	75	/
	{ MSC-C09TV - E1 MUH-C09TV - E1			
{ MSC-C12TV - E1 MUH-C12TV - E1				1250

Calculation : $X_g = 25\text{g/m} \times (\text{Refrigerant piping length (m)} - 7)$

MSC-C07TV -E1 MU-C07TV -E1 MUH-C07TV -E1

MSC-C09TV -E1 MU-C09TV -E1 MUH-C09TV -E1

MSC-C12TV -E1 MU-C12TV -E1 MUH-C12TV -E1

The standard data contained in these specifications apply only to the operation of the air conditioner under normal conditions. Since operating conditions vary according to the areas where these units are installed. The following information has been provided to clarify the operating characteristics of the air conditioner under the conditions indicated by the performance curve.

(1) GUARANTEED VOLTAGE

Rated voltage : 198 ~ 264V, 50Hz

(2) AIR FLOW

Air flow should be set at MAX.

(3) MAIN READINGS

- | | | |
|---|------|-------------------------------|
| (1) Indoor intake air wet-bulb temperature : | °CWB | } Cooling |
| (2) Indoor outlet air wet-bulb temperature : | °CWB | |
| (3) Outdoor intake air dry-bulb temperature : | °CDB | |
| (4) Total input: | W | } Heating <MUH-C07/C09/C12TV> |
| (5) Indoor intake air dry-bulb temperature : | °CDB | |
| (6) Outdoor intake air wet-bulb temperature : | °CWB | |
| (7) Total input : | W | |

Indoor air wet/dry-bulb temperature difference on the left side of the chart on this page and next page shows the difference between the indoor intake air wet/dry-bulb temperature and the indoor outlet air wet/dry-bulb temperature for your reference at service.

How to measure the indoor air wet-bulb/dry-bulb temperature difference

- Attach at least 2 sets of wet-and dry-bulb thermometers to the indoor air intake as shown in the figure, and at least 2 sets of wet-and dry-bulb thermometers to the indoor air outlet. The thermometers must be attached to the position where air speed is high.
- Attach at least 2 sets of wet-and dry-bulb thermometers to the outdoor air intake. Cover the thermometers to prevent direct rays of the sun.
- Check that the air filter is cleaned.
- Open windows and doors of room.
- Press the EMERGENCY OPERATION switch once(twice) to start the EMERGENCY COOL(HEAT<MUH-C07/C09/C12 TV>) MODE.
- When system stabilizes after more than 15 minutes, measure temperature and take an average temperature.
- 10 minutes later, measure temperature again and check that the temperature does not change.

INDOOR UNIT

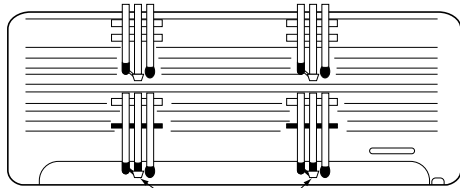

Wet-and dry-bulb thermometers
FRONT VIEW

OUTDOOR UNIT

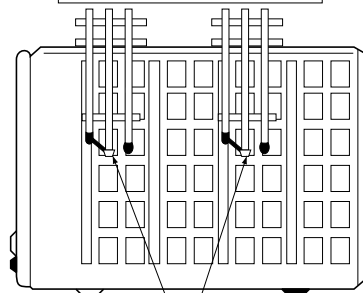

Wet-and dry-bulb thermometers
BACK VIEW

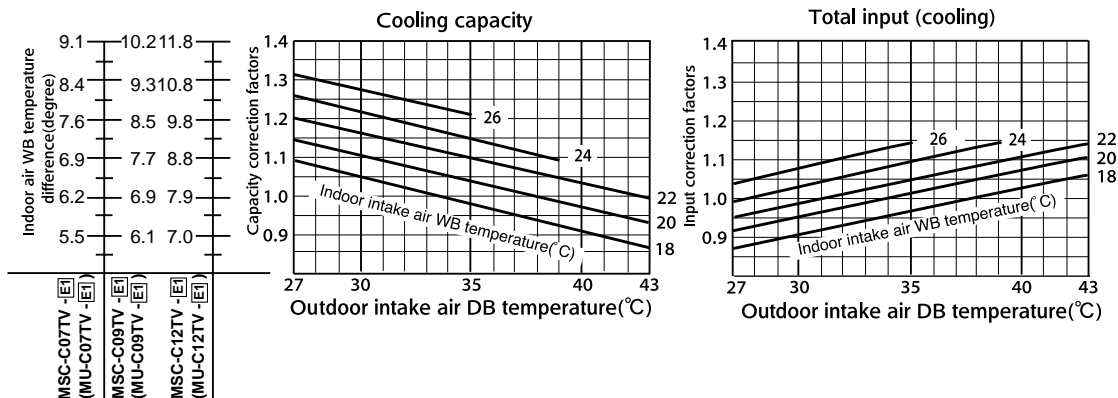

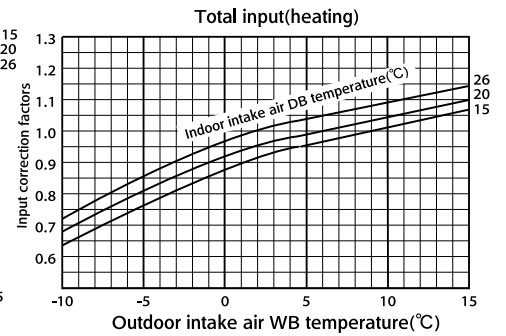
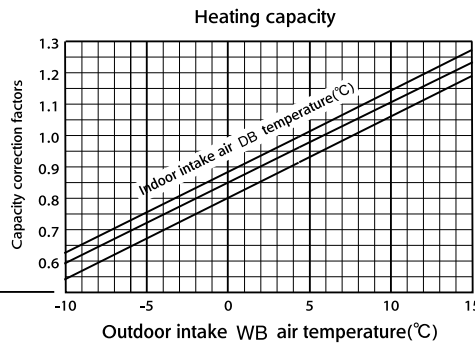
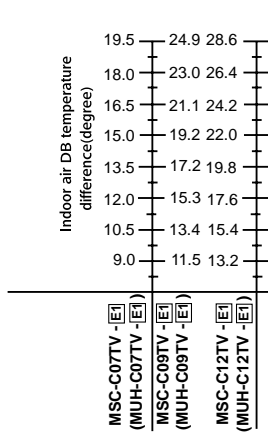
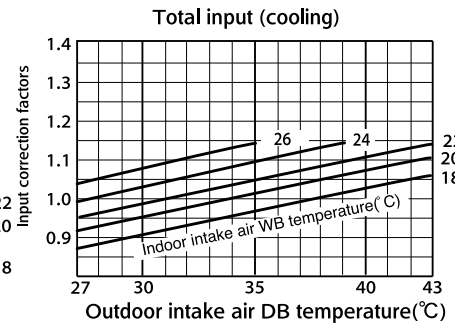
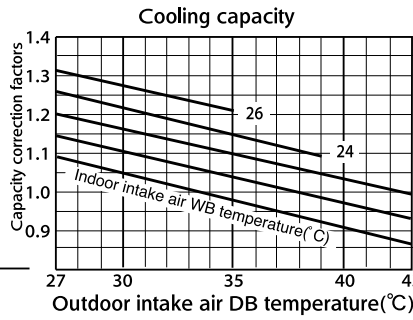
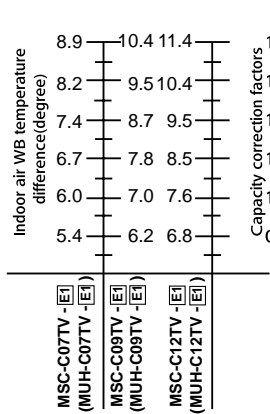

NOTE: The above curves are for the heating operation without any frost.

OUTDOOR LOW PRESSURE AND OUTDOOR UNIT CURRENT COOL operation

① Both indoor and outdoor unit are under the same temperature/humidity condition.

Dry-bulb temperature	Relative humidity(%)
20	50
25	60
30	70

② Air flow should be set at MAX.

③ The unit of pressure has been changed to MPa on the international system of units(SI unit system).

The conversion factor is : **1(MPa[Gage]) = 10.2(kgf/cm²[Gage])**

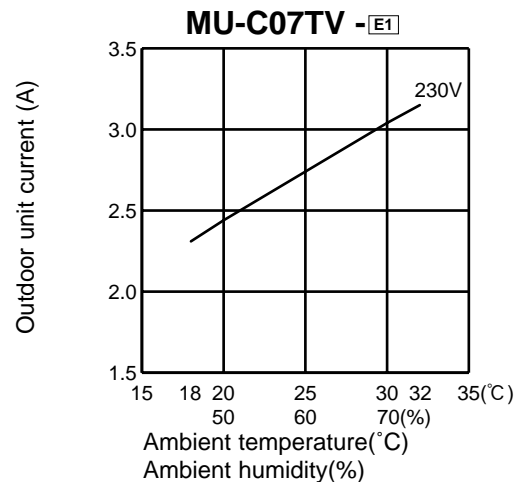
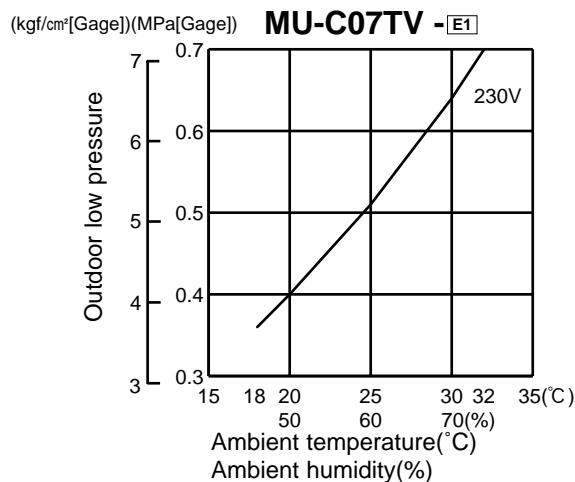

(kgf/cm²[Gage])(MPa[Gage])

MU-C09TV -[E1]

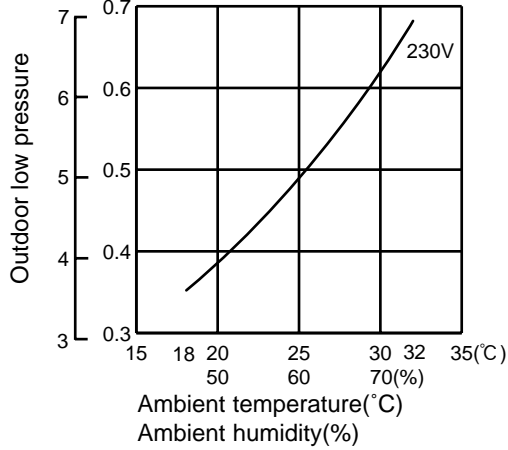

MU-C09TV -[E1]

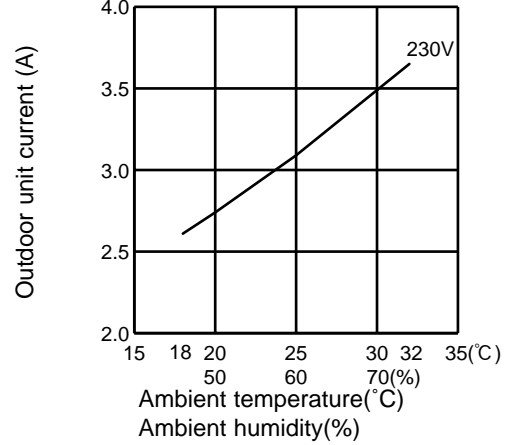

(kgf/cm²[Gage])(MPa[Gage])

MU-C12TV -[E1]

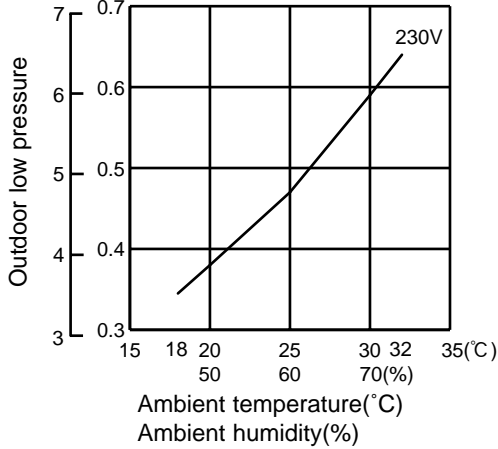

MU-C12TV -[E1]

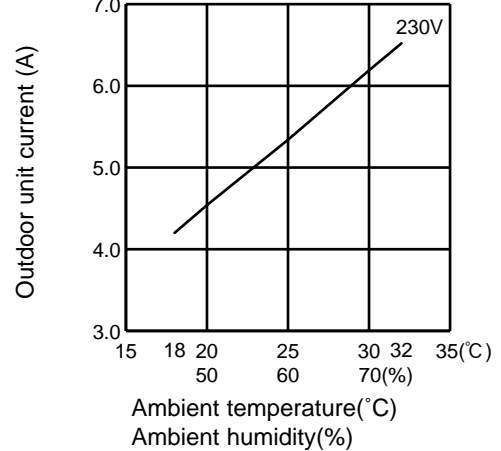

(kgf/cm²[Gage])(MPa[Gage])

MUH-C07TV -[E1]

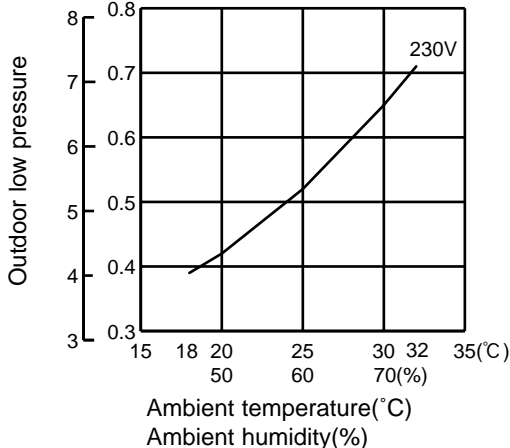

MUH-C07TV -[E1]

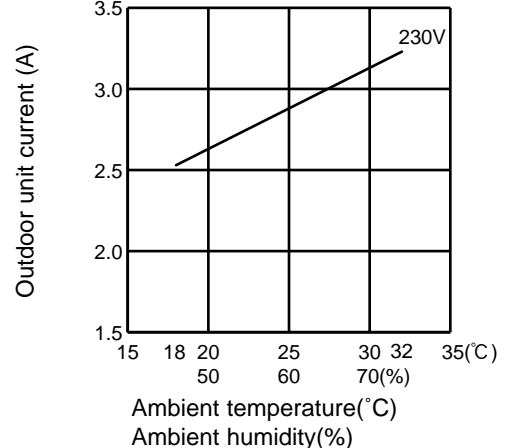

(kgf/cm²[Gage])(MPa[Gage])

MUH-C09TV -[E1]

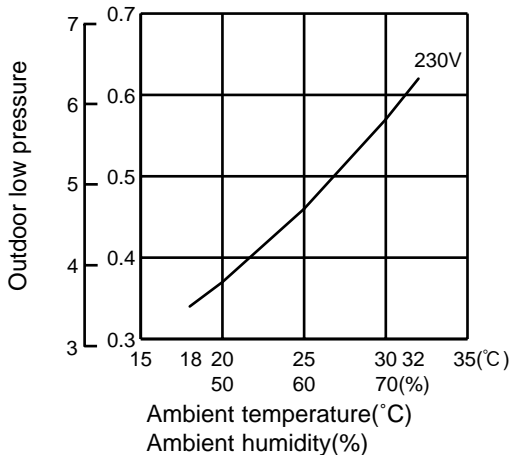

MUH-C09TV -[E1]

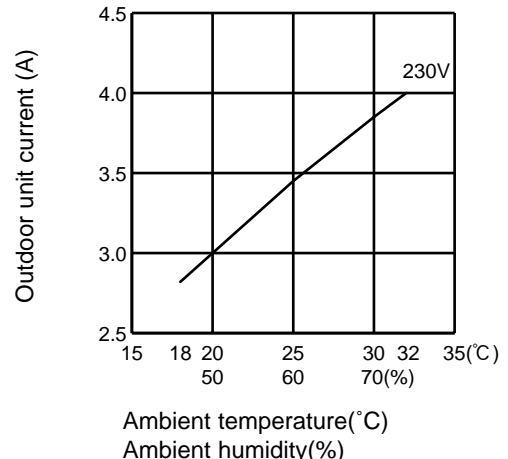

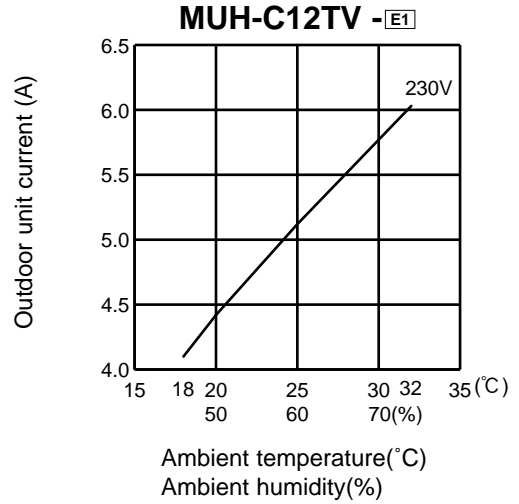
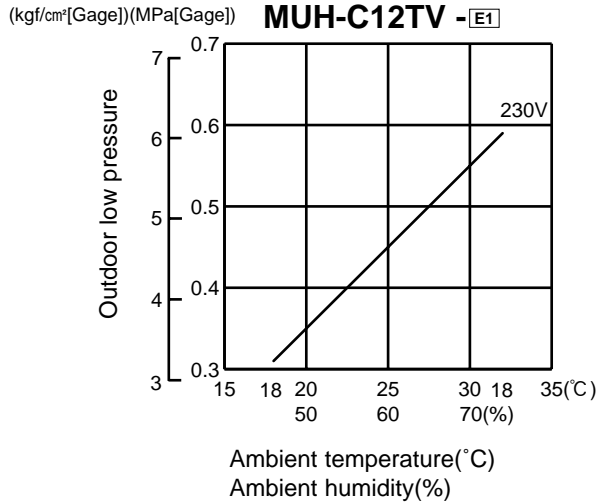

HEAT operation

Condition indoor: Dry bulb temperature 20.0°C
Wet bulb temperature 14.5°C

Outdoor: Dry bulb temperature 7,15,20°C
Wet bulb temperature 6,12,14.5°C

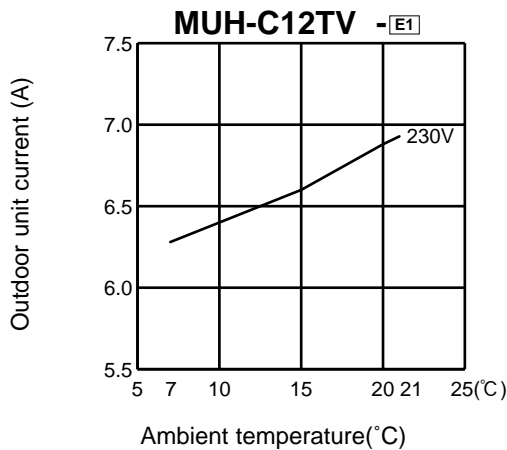
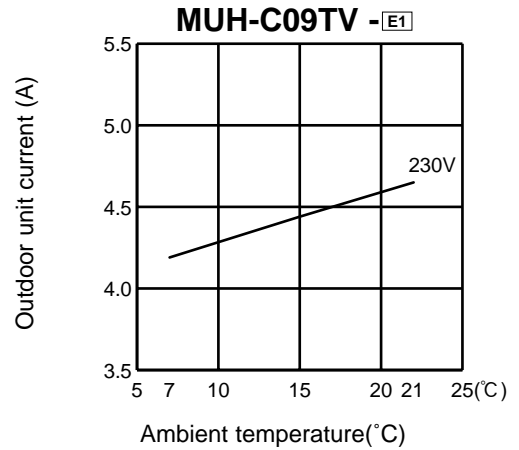
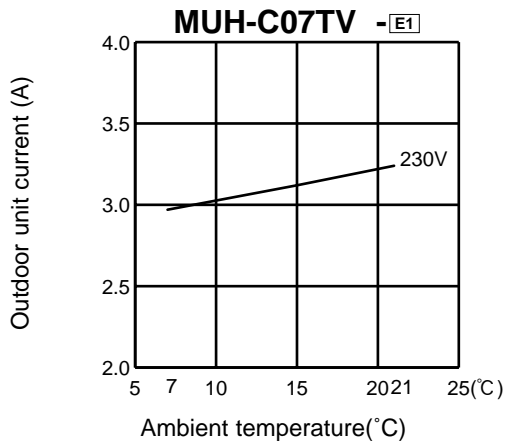

PERFORMANCE DATA COOL operation
MSC-C07TV -E1 : MU-C07TV -E1

CAPACITY: 2.25(KW) SHF: 0.75 INPUT: 730(W)

		OUTDOOR DB(°C)															
INDOOR DB(°C)	INDOOR WB(°C)	21				25				27				30			
		Q	SHC	SHF	INPUT	Q	SHC	SHF	INPUT	Q	SHC	SHF	INPUT	Q	SHC	SHF	INPUT
21	18	2.64	1.51	0.57	584	2.53	1.44	0.57	613	2.43	1.39	0.57	642	2.34	1.33	0.57	672
21	20	2.76	1.24	0.45	613	2.64	1.19	0.45	650	2.57	1.15	0.45	664	2.48	1.11	0.45	694
22	18	2.64	1.61	0.61	584	2.53	1.54	0.61	613	2.43	1.48	0.61	642	2.34	1.43	0.61	672
22	20	2.76	1.35	0.49	613	2.64	1.30	0.49	650	2.57	1.26	0.49	664	2.48	1.21	0.49	694
22	22	2.87	1.06	0.37	635	2.77	1.02	0.37	675	2.70	1.00	0.37	694	2.59	0.96	0.37	723
23	18	2.64	1.72	0.65	584	2.53	1.65	0.65	613	2.43	1.58	0.65	642	2.34	1.52	0.65	672
23	20	2.76	1.46	0.53	613	2.64	1.40	0.53	650	2.57	1.36	0.53	664	2.48	1.31	0.53	694
23	22	2.87	1.18	0.41	635	2.77	1.13	0.41	675	2.70	1.11	0.41	694	2.59	1.06	0.41	723
24	18	2.64	1.82	0.69	584	2.53	1.75	0.69	613	2.43	1.68	0.69	642	2.34	1.61	0.69	672
24	20	2.76	1.57	0.57	613	2.64	1.51	0.57	650	2.57	1.46	0.57	664	2.48	1.41	0.57	694
24	22	2.87	1.29	0.45	635	2.77	1.25	0.45	675	2.70	1.22	0.45	694	2.59	1.16	0.45	723
24	24	3.02	0.99	0.33	664	2.90	0.96	0.33	701	2.84	0.94	0.33	723	2.75	0.91	0.33	759
25	18	2.64	1.93	0.73	584	2.53	1.85	0.73	613	2.43	1.77	0.73	642	2.34	1.71	0.73	672
25	20	2.76	1.68	0.61	613	2.64	1.61	0.61	650	2.57	1.56	0.61	664	2.48	1.51	0.61	694
25	22	2.87	1.41	0.49	635	2.77	1.36	0.49	675	2.70	1.32	0.49	694	2.59	1.27	0.49	723
25	24	3.02	1.12	0.37	664	2.90	1.07	0.37	701	2.84	1.05	0.37	723	2.75	1.02	0.37	759
26	18	2.64	2.04	0.77	584	2.53	1.95	0.77	613	2.43	1.87	0.77	642	2.34	1.80	0.77	672
26	20	2.76	1.79	0.65	613	2.64	1.72	0.65	650	2.57	1.67	0.65	664	2.48	1.61	0.65	694
26	22	2.87	1.52	0.53	635	2.77	1.47	0.53	675	2.70	1.43	0.53	694	2.59	1.37	0.53	723
26	24	3.02	1.24	0.41	664	2.90	1.19	0.41	701	2.84	1.16	0.41	723	2.75	1.13	0.41	759
26	26	3.11	0.90	0.29	701	3.02	0.87	0.29	737	2.97	0.86	0.29	759	2.88	0.84	0.29	781
27	18	2.64	2.14	0.81	584	2.53	2.05	0.81	613	2.43	1.97	0.81	642	2.34	1.90	0.81	672
27	20	2.76	1.90	0.69	613	2.64	1.82	0.69	650	2.57	1.77	0.69	664	2.48	1.71	0.69	694
27	22	2.87	1.64	0.57	635	2.77	1.58	0.57	675	2.70	1.54	0.57	694	2.59	1.47	0.57	723
27	24	3.02	1.36	0.45	664	2.90	1.31	0.45	701	2.84	1.28	0.45	723	2.75	1.24	0.45	759
27	26	3.11	1.02	0.33	701	3.02	0.99	0.33	737	2.97	0.98	0.33	759	2.88	0.95	0.33	781
28	18	2.64	2.25	0.85	584	2.53	2.15	0.85	613	2.43	2.07	0.85	642	2.34	1.99	0.85	672
28	20	2.76	2.01	0.73	613	2.64	1.93	0.73	650	2.57	1.87	0.73	664	2.48	1.81	0.73	694
28	22	2.87	1.75	0.61	635	2.77	1.69	0.61	675	2.70	1.65	0.61	694	2.59	1.58	0.61	723
28	24	3.02	1.48	0.49	664	2.90	1.42	0.49	701	2.84	1.39	0.49	723	2.75	1.35	0.49	759
28	26	3.11	1.15	0.37	701	3.02	1.12	0.37	737	2.97	1.10	0.37	759	2.88	1.07	0.37	781
29	18	2.64	2.35	0.89	584	2.53	2.25	0.89	613	2.43	2.16	0.89	642	2.34	2.08	0.89	672
29	20	2.76	2.12	0.77	613	2.64	2.04	0.77	650	2.57	1.98	0.77	664	2.48	1.91	0.77	694
29	22	2.87	1.86	0.65	635	2.77	1.80	0.65	675	2.70	1.76	0.65	694	2.59	1.68	0.65	723
29	24	3.02	1.60	0.53	664	2.90	1.54	0.53	701	2.84	1.50	0.53	723	2.75	1.45	0.53	759
29	26	3.11	1.27	0.41	701	3.02	1.24	0.41	737	2.97	1.22	0.41	759	2.88	1.18	0.41	781
30	18	2.64	2.46	0.93	584	2.53	2.35	0.93	613	2.43	2.26	0.93	642	2.34	2.18	0.93	672
30	20	2.76	2.23	0.81	613	2.64	2.14	0.81	650	2.57	2.08	0.81	664	2.48	2.00	0.81	694
30	22	2.87	1.98	0.69	635	2.77	1.91	0.69	675	2.70	1.86	0.69	694	2.59	1.79	0.69	723
30	24	3.02	1.72	0.57	664	2.90	1.65	0.57	701	2.84	1.62	0.57	723	2.75	1.56	0.57	759
30	26	3.11	1.40	0.45	701	3.02	1.36	0.45	737	2.97	1.34	0.45	759	2.88	1.30	0.45	781
31	18	2.64	2.56	0.97	584	2.53	2.46	0.97	613	2.43	2.36	0.97	642	2.34	2.27	0.97	672
31	20	2.76	2.34	0.85	613	2.64	2.25	0.85	650	2.57	2.18	0.85	664	2.48	2.10	0.85	694
31	22	2.87	2.09	0.73	635	2.77	2.02	0.73	675	2.70	1.97	0.73	694	2.59	1.89	0.73	723
31	24	3.02	1.84	0.61	664	2.90	1.77	0.61	701	2.84	1.73	0.61	723	2.75	1.67	0.61	759
31	26	3.11	1.52	0.49	701	3.02	1.48	0.49	737	2.97	1.46	0.49	759	2.88	1.41	0.49	781
32	18	2.64	2.67	1.01	584	2.53	2.56	1.01	613	2.43	2.45	1.01	642	2.34	2.36	1.01	672
32	20	2.76	2.45	0.89	613	2.64	2.35	0.89	650	2.57	2.28	0.89	664	2.48	2.20	0.89	694
32	22	2.87	2.21	0.77	635	2.77	2.13	0.77	675	2.70	2.08	0.77	694	2.59	1.99	0.77	723
32	24	3.02	1.96	0.65	664	2.90	1.89	0.65	701	2.84	1.84	0.65	723	2.75	1.78	0.65	759
32	26	3.11	1.65	0.53	701	3.02	1.60	0.53	737	2.97	1.57	0.53	759	2.88	1.53	0.53	781

NOTE Q : Total capacity (kW) SHF : Sensible heat factor DB : Dry-bulb temperature
 SHC : Sensible heat capacity (kW) INPUT : Total power input (W) WB : Wet-bulb temperature

PERFORMANCE DATA COOL operation
MSC-C07TV -E1 : MU-C07TV -E1

CAPACITY: 2.25(KW) SHF: 0.75 INPUT: 730(W)

		OUTDOOR DB(°C)															
INDOOR DB(°C)	INDOOR WB(°C)	35				40				43				46			
		Q	SHC	SHF	INPUT	Q	SHC	SHF	INPUT	Q	SHC	SHF	INPUT	Q	SHC	SHF	INPUT
21	18	2.21	1.26	0.57	715	2.03	1.15	0.57	759	1.95	1.11	0.57	774	1.87	1.06	0.57	788
21	20	2.32	1.04	0.45	745	2.16	0.97	0.45	781	2.08	0.94	0.45	803	2.00	0.90	0.45	825
22	18	2.21	1.35	0.61	715	2.03	1.24	0.61	759	1.95	1.19	0.61	774	1.87	1.14	0.61	788
22	20	2.32	1.14	0.49	745	2.16	1.06	0.49	781	2.08	1.02	0.49	803	2.00	0.98	0.49	825
22	22	2.45	0.91	0.37	774	2.30	0.85	0.37	818	2.22	0.82	0.37	832	2.14	0.79	0.37	847
23	18	2.21	1.43	0.65	715	2.03	1.32	0.65	759	1.95	1.27	0.65	774	1.87	1.21	0.65	788
23	20	2.32	1.23	0.53	745	2.16	1.14	0.53	781	2.08	1.10	0.53	803	2.00	1.06	0.53	825
23	22	2.45	1.01	0.41	774	2.30	0.94	0.41	818	2.22	0.91	0.41	832	2.14	0.88	0.41	847
24	18	2.21	1.52	0.69	715	2.03	1.40	0.69	759	1.95	1.34	0.69	774	1.87	1.29	0.69	788
24	20	2.32	1.32	0.57	745	2.16	1.23	0.57	781	2.08	1.19	0.57	803	2.00	1.14	0.57	825
24	22	2.45	1.10	0.45	774	2.30	1.03	0.45	818	2.22	1.00	0.45	832	2.14	0.96	0.45	847
24	24	2.59	0.85	0.33	803	2.43	0.80	0.33	840	2.36	0.78	0.33	858	2.30	0.76	0.33	876
25	18	2.21	1.61	0.73	715	2.03	1.48	0.73	759	1.95	1.42	0.73	774	1.87	1.36	0.73	788
25	20	2.32	1.41	0.61	745	2.16	1.32	0.61	781	2.08	1.27	0.61	803	2.00	1.22	0.61	825
25	22	2.45	1.20	0.49	774	2.30	1.12	0.49	818	2.22	1.09	0.49	832	2.14	1.05	0.49	847
25	24	2.59	0.96	0.37	803	2.43	0.90	0.37	840	2.36	0.87	0.37	858	2.30	0.85	0.37	876
26	18	2.21	1.70	0.77	715	2.03	1.56	0.77	759	1.95	1.50	0.77	774	1.87	1.44	0.77	788
26	20	2.32	1.51	0.65	745	2.16	1.40	0.65	781	2.08	1.35	0.65	803	2.00	1.30	0.65	825
26	22	2.45	1.30	0.53	774	2.30	1.22	0.53	818	2.22	1.17	0.53	832	2.14	1.13	0.53	847
26	24	2.59	1.06	0.41	803	2.43	1.00	0.41	840	2.36	0.97	0.41	858	2.30	0.94	0.41	876
26	26	2.72	0.79	0.29	832	2.57	0.74	0.29	869	2.49	0.72	0.29	887	2.41	0.70	0.29	905
27	18	2.21	1.79	0.81	715	2.03	1.64	0.81	759	1.95	1.58	0.81	774	1.87	1.51	0.81	788
27	20	2.32	1.60	0.69	745	2.16	1.49	0.69	781	2.08	1.44	0.69	803	2.00	1.38	0.69	825
27	22	2.45	1.40	0.57	774	2.30	1.31	0.57	818	2.22	1.26	0.57	832	2.14	1.22	0.57	847
27	24	2.59	1.16	0.45	803	2.43	1.09	0.45	840	2.36	1.06	0.45	858	2.30	1.03	0.45	876
27	26	2.72	0.90	0.33	832	2.57	0.85	0.33	869	2.49	0.82	0.33	887	2.41	0.79	0.33	905
28	18	2.21	1.87	0.85	715	2.03	1.72	0.85	759	1.95	1.65	0.85	774	1.87	1.59	0.85	788
28	20	2.32	1.69	0.73	745	2.16	1.58	0.73	781	2.08	1.52	0.73	803	2.00	1.46	0.73	825
28	22	2.45	1.50	0.61	774	2.30	1.40	0.61	818	2.22	1.35	0.61	832	2.14	1.30	0.61	847
28	24	2.59	1.27	0.49	803	2.43	1.19	0.49	840	2.36	1.16	0.49	858	2.30	1.12	0.49	876
28	26	2.72	1.01	0.37	832	2.57	0.95	0.37	869	2.49	0.92	0.37	887	2.41	0.89	0.37	905
29	18	2.21	1.96	0.89	715	2.03	1.80	0.89	759	1.95	1.73	0.89	774	1.87	1.66	0.89	788
29	20	2.32	1.78	0.77	745	2.16	1.66	0.77	781	2.08	1.60	0.77	803	2.00	1.54	0.77	825
29	22	2.45	1.59	0.65	774	2.30	1.49	0.65	818	2.22	1.44	0.65	832	2.14	1.39	0.65	847
29	24	2.59	1.37	0.53	803	2.43	1.29	0.53	840	2.36	1.25	0.53	858	2.30	1.22	0.53	876
29	26	2.72	1.12	0.41	832	2.57	1.05	0.41	869	2.49	1.02	0.41	887	2.41	0.99	0.41	905
30	18	2.21	2.05	0.93	715	2.03	1.88	0.93	759	1.95	1.81	0.93	774	1.87	1.74	0.93	788
30	20	2.32	1.88	0.81	745	2.16	1.75	0.81	781	2.08	1.69	0.81	803	2.00	1.62	0.81	825
30	22	2.45	1.69	0.69	774	2.30	1.58	0.69	818	2.22	1.53	0.69	832	2.14	1.47	0.69	847
30	24	2.59	1.47	0.57	803	2.43	1.39	0.57	840	2.36	1.35	0.57	858	2.30	1.31	0.57	876
30	26	2.72	1.23	0.45	832	2.57	1.15	0.45	869	2.49	1.12	0.45	887	2.41	1.08	0.45	905
31	18	2.21	2.14	0.97	715	2.03	1.96	0.97	759	1.95	1.89	0.97	774	1.87	1.81	0.97	788
31	20	2.32	1.97	0.85	745	2.16	1.84	0.85	781	2.08	1.77	0.85	803	2.00	1.70	0.85	825
31	22	2.45	1.79	0.73	774	2.30	1.68	0.73	818	2.22	1.62	0.73	832	2.14	1.56	0.73	847
31	24	2.59	1.58	0.61	803	2.43	1.48	0.61	840	2.36	1.44	0.61	858	2.30	1.40	0.61	876
31	26	2.72	1.33	0.49	832	2.57	1.26	0.49	869	2.49	1.22	0.49	887	2.41	1.18	0.49	905
32	18	2.21	2.23	1.01	715	2.03	2.05	1.01	759	1.95	1.97	1.01	774	1.87	1.89	1.01	788
32	20	2.32	2.06	0.89	745	2.16	1.92	0.89	781	2.08	1.85	0.89	803	2.00	1.78	0.89	825
32	22	2.45	1.89	0.77	774	2.30	1.77	0.77	818	2.22	1.71	0.77	832	2.14	1.65	0.77	847
32	24	2.59	1.68	0.65	803	2.43	1.58	0.65	840	2.36	1.54	0.65	858	2.30	1.49	0.65	876
32	26	2.72	1.44	0.53	832	2.57	1.36	0.53	869	2.49	1.32	0.53	887	2.41	1.28	0.53	905

NOTE Q : Total capacity (kW) SHF : Sensible heat factor DB : Dry-bulb temperature
 SHC : Sensible heat capacity (kW) INPUT : Total power input (W) WB : Wet-bulb temperature

PERFORMANCE DATA COOL operation
MSC-C09TV -E1 : MU-C09TV -E1

CAPACITY: 2.50(KW) SHF: 0.73 INPUT: 830(W)

INDOOR DB(°C)	INDOOR WB(°C)	OUTDOOR DB(°C)															
		21				25				27				30			
		Q	SHC	SHF	INPUT	Q	SHC	SHF	INPUT	Q	SHC	SHF	INPUT	Q	SHC	SHF	INPUT
21	18	2.94	1.62	0.55	664	2.81	1.55	0.55	697	2.70	1.49	0.55	730	2.60	1.43	0.55	764
21	20	3.06	1.32	0.43	697	2.94	1.26	0.43	739	2.85	1.23	0.43	755	2.75	1.18	0.43	789
22	18	2.94	1.73	0.59	664	2.81	1.66	0.59	697	2.70	1.59	0.59	730	2.60	1.53	0.59	764
22	20	3.06	1.44	0.47	697	2.94	1.38	0.47	739	2.85	1.34	0.47	755	2.75	1.29	0.47	789
22	22	3.19	1.12	0.35	722	3.08	1.08	0.35	768	3.00	1.05	0.35	789	2.88	1.01	0.35	822
23	18	2.94	1.85	0.63	664	2.81	1.77	0.63	697	2.70	1.70	0.63	730	2.60	1.64	0.63	764
23	20	3.06	1.56	0.51	697	2.94	1.50	0.51	739	2.85	1.45	0.51	755	2.75	1.40	0.51	789
23	22	3.19	1.24	0.39	722	3.08	1.20	0.39	768	3.00	1.17	0.39	789	2.88	1.12	0.39	822
24	18	2.94	1.97	0.67	664	2.81	1.88	0.67	697	2.70	1.81	0.67	730	2.60	1.74	0.67	764
24	20	3.06	1.68	0.55	697	2.94	1.62	0.55	739	2.85	1.57	0.55	755	2.75	1.51	0.55	789
24	22	3.19	1.37	0.43	722	3.08	1.32	0.43	768	3.00	1.29	0.43	789	2.88	1.24	0.43	822
24	24	3.35	1.04	0.31	755	3.23	1.00	0.31	797	3.15	0.98	0.31	822	3.05	0.95	0.31	863
25	18	2.94	2.09	0.71	664	2.81	2.00	0.71	697	2.70	1.92	0.71	730	2.60	1.85	0.71	764
25	20	3.06	1.81	0.59	697	2.94	1.73	0.59	739	2.85	1.68	0.59	755	2.75	1.62	0.59	789
25	22	3.19	1.50	0.47	722	3.08	1.45	0.47	768	3.00	1.41	0.47	789	2.88	1.35	0.47	822
25	24	3.35	1.17	0.35	755	3.23	1.13	0.35	797	3.15	1.10	0.35	822	3.05	1.07	0.35	863
26	18	2.94	2.20	0.75	664	2.81	2.11	0.75	697	2.70	2.03	0.75	730	2.60	1.95	0.75	764
26	20	3.06	1.93	0.63	697	2.94	1.85	0.63	739	2.85	1.80	0.63	755	2.75	1.73	0.63	789
26	22	3.19	1.63	0.51	722	3.08	1.57	0.51	768	3.00	1.53	0.51	789	2.88	1.47	0.51	822
26	24	3.35	1.31	0.39	755	3.23	1.26	0.39	797	3.15	1.23	0.39	822	3.05	1.19	0.39	863
26	26	3.45	0.93	0.27	797	3.35	0.90	0.27	838	3.30	0.89	0.27	863	3.20	0.86	0.27	888
27	18	2.94	2.32	0.79	664	2.81	2.22	0.79	697	2.70	2.13	0.79	730	2.60	2.05	0.79	764
27	20	3.06	2.05	0.67	697	2.94	1.97	0.67	739	2.85	1.91	0.67	755	2.75	1.84	0.67	789
27	22	3.19	1.75	0.55	722	3.08	1.69	0.55	768	3.00	1.65	0.55	789	2.88	1.58	0.55	822
27	24	3.35	1.44	0.43	755	3.23	1.39	0.43	797	3.15	1.35	0.43	822	3.05	1.31	0.43	863
27	26	3.45	1.07	0.31	797	3.35	1.04	0.31	838	3.30	1.02	0.31	863	3.20	0.99	0.31	888
28	18	2.94	2.44	0.83	664	2.81	2.33	0.83	697	2.70	2.24	0.83	730	2.60	2.16	0.83	764
28	20	3.06	2.17	0.71	697	2.94	2.09	0.71	739	2.85	2.02	0.71	755	2.75	1.95	0.71	789
28	22	3.19	1.88	0.59	722	3.08	1.81	0.59	768	3.00	1.77	0.59	789	2.88	1.70	0.59	822
28	24	3.35	1.57	0.47	755	3.23	1.52	0.47	797	3.15	1.48	0.47	822	3.05	1.43	0.47	863
28	26	3.45	1.21	0.35	797	3.35	1.17	0.35	838	3.30	1.16	0.35	863	3.20	1.12	0.35	888
29	18	2.94	2.56	0.87	664	2.81	2.45	0.87	697	2.70	2.35	0.87	730	2.60	2.26	0.87	764
29	20	3.06	2.30	0.75	697	2.94	2.20	0.75	739	2.85	2.14	0.75	755	2.75	2.06	0.75	789
29	22	3.19	2.01	0.63	722	3.08	1.94	0.63	768	3.00	1.89	0.63	789	2.88	1.81	0.63	822
29	24	3.35	1.71	0.51	755	3.23	1.64	0.51	797	3.15	1.61	0.51	822	3.05	1.56	0.51	863
29	26	3.45	1.35	0.39	797	3.35	1.31	0.39	838	3.30	1.29	0.39	863	3.20	1.25	0.39	888
30	18	2.94	2.67	0.91	664	2.81	2.56	0.91	697	2.70	2.46	0.91	730	2.60	2.37	0.91	764
30	20	3.06	2.42	0.79	697	2.94	2.32	0.79	739	2.85	2.25	0.79	755	2.75	2.17	0.79	789
30	22	3.19	2.14	0.67	722	3.08	2.06	0.67	768	3.00	2.01	0.67	789	2.88	1.93	0.67	822
30	24	3.35	1.84	0.55	755	3.23	1.77	0.55	797	3.15	1.73	0.55	822	3.05	1.68	0.55	863
30	26	3.45	1.48	0.43	797	3.35	1.44	0.43	838	3.30	1.42	0.43	863	3.20	1.38	0.43	888
31	18	2.94	2.79	0.95	664	2.81	2.67	0.95	697	2.70	2.57	0.95	730	2.60	2.47	0.95	764
31	20	3.06	2.54	0.83	697	2.94	2.44	0.83	739	2.85	2.37	0.83	755	2.75	2.28	0.83	789
31	22	3.19	2.26	0.71	722	3.08	2.18	0.71	768	3.00	2.13	0.71	789	2.88	2.04	0.71	822
31	24	3.35	1.98	0.59	755	3.23	1.90	0.59	797	3.15	1.86	0.59	822	3.05	1.80	0.59	863
31	26	3.45	1.62	0.47	797	3.35	1.57	0.47	838	3.30	1.55	0.47	863	3.20	1.50	0.47	888
32	18	2.94	2.91	0.99	664	2.81	2.78	0.99	697	2.70	2.67	0.99	730	2.60	2.57	0.99	764
32	20	3.06	2.66	0.87	697	2.94	2.56	0.87	739	2.85	2.48	0.87	755	2.75	2.39	0.87	789
32	22	3.19	2.39	0.75	722	3.08	2.31	0.75	768	3.00	2.25	0.75	789	2.88	2.16	0.75	822
32	24	3.35	2.11	0.63	755	3.23	2.03	0.63	797	3.15	1.98	0.63	822	3.05	1.92	0.63	863
32	26	3.45	1.76	0.51	797	3.35	1.71	0.51	838	3.30	1.68	0.51	863	3.20	1.63	0.51	888

NOTE Q : Total capacity (kW) SHF : Sensible heat factor DB : Dry-bulb temperature
SHC : Sensible heat capacity (kW) INPUT : Total power input (W) WB : Wet-bulb temperature

PERFORMANCE DATA COOL operation

MSC-C09TV -E1 : MU-C09TV -E1

CAPACITY: 2.50(KW) SHF: 0.73 INPUT: 830(W)

INDOOR DB(°C)	INDOOR WB(°C)	OUTDOOR DB(°C)															
		35				40				43				46			
		Q	SHC	SHF	INPUT	Q	SHC	SHF	INPUT	Q	SHC	SHF	INPUT	Q	SHC	SHF	INPUT
21	18	2.45	1.35	0.55	813	2.25	1.24	0.55	863	2.16	1.19	0.55	880	2.08	1.14	0.55	896
21	20	2.58	1.11	0.43	847	2.40	1.03	0.43	888	2.31	0.99	0.43	913	2.23	0.96	0.43	938
22	18	2.45	1.45	0.59	813	2.25	1.33	0.59	863	2.16	1.28	0.59	880	2.08	1.22	0.59	896
22	20	2.58	1.21	0.47	847	2.40	1.13	0.47	888	2.31	1.09	0.47	913	2.23	1.05	0.47	938
22	22	2.73	0.95	0.35	880	2.55	0.89	0.35	930	2.46	0.86	0.35	946	2.38	0.83	0.35	963
23	18	2.45	1.54	0.63	813	2.25	1.42	0.63	863	2.16	1.36	0.63	880	2.08	1.31	0.63	896
23	20	2.58	1.31	0.51	847	2.40	1.22	0.51	888	2.31	1.18	0.51	913	2.23	1.13	0.51	938
23	22	2.73	1.06	0.39	880	2.55	0.99	0.39	930	2.46	0.96	0.39	946	2.38	0.93	0.39	963
24	18	2.45	1.64	0.67	813	2.25	1.51	0.67	863	2.16	1.45	0.67	880	2.08	1.39	0.67	896
24	20	2.58	1.42	0.55	847	2.40	1.32	0.55	888	2.31	1.27	0.55	913	2.23	1.22	0.55	938
24	22	2.73	1.17	0.43	880	2.55	1.10	0.43	930	2.46	1.06	0.43	946	2.38	1.02	0.43	963
24	24	2.88	0.89	0.31	913	2.70	0.84	0.31	955	2.63	0.81	0.31	975	2.55	0.79	0.31	996
25	18	2.45	1.74	0.71	813	2.25	1.60	0.71	863	2.16	1.54	0.71	880	2.08	1.47	0.71	896
25	20	2.58	1.52	0.59	847	2.40	1.42	0.59	888	2.31	1.36	0.59	913	2.23	1.31	0.59	938
25	22	2.73	1.28	0.47	880	2.55	1.20	0.47	930	2.46	1.16	0.47	946	2.38	1.12	0.47	963
25	24	2.88	1.01	0.35	913	2.70	0.95	0.35	955	2.63	0.92	0.35	975	2.55	0.89	0.35	996
26	18	2.45	1.84	0.75	813	2.25	1.69	0.75	863	2.16	1.62	0.75	880	2.08	1.56	0.75	896
26	20	2.58	1.62	0.63	847	2.40	1.51	0.63	888	2.31	1.46	0.63	913	2.23	1.40	0.63	938
26	22	2.73	1.39	0.51	880	2.55	1.30	0.51	930	2.46	1.26	0.51	946	2.38	1.21	0.51	963
26	24	2.88	1.12	0.39	913	2.70	1.05	0.39	955	2.63	1.02	0.39	975	2.55	0.99	0.39	996
26	26	3.03	0.82	0.27	946	2.85	0.77	0.27	988	2.76	0.75	0.27	1008	2.68	0.72	0.27	1029
27	18	2.45	1.94	0.79	813	2.25	1.78	0.79	863	2.16	1.71	0.79	880	2.08	1.64	0.79	896
27	20	2.58	1.73	0.67	847	2.40	1.61	0.67	888	2.31	1.55	0.67	913	2.23	1.49	0.67	938
27	22	2.73	1.50	0.55	880	2.55	1.40	0.55	930	2.46	1.35	0.55	946	2.38	1.31	0.55	963
27	24	2.88	1.24	0.43	913	2.70	1.16	0.43	955	2.63	1.13	0.43	975	2.55	1.10	0.43	996
27	26	3.03	0.94	0.31	946	2.85	0.88	0.31	988	2.76	0.86	0.31	1008	2.68	0.83	0.31	1029
28	18	2.45	2.03	0.83	813	2.25	1.87	0.83	863	2.16	1.79	0.83	880	2.08	1.72	0.83	896
28	20	2.58	1.83	0.71	847	2.40	1.70	0.71	888	2.31	1.64	0.71	913	2.23	1.58	0.71	938
28	22	2.73	1.61	0.59	880	2.55	1.50	0.59	930	2.46	1.45	0.59	946	2.38	1.40	0.59	963
28	24	2.88	1.35	0.47	913	2.70	1.27	0.47	955	2.63	1.23	0.47	975	2.55	1.20	0.47	996
28	26	3.03	1.06	0.35	946	2.85	1.00	0.35	988	2.76	0.97	0.35	1008	2.68	0.94	0.35	1029
29	18	2.45	2.13	0.87	813	2.25	1.96	0.87	863	2.16	1.88	0.87	880	2.08	1.81	0.87	896
29	20	2.58	1.93	0.75	847	2.40	1.80	0.75	888	2.31	1.73	0.75	913	2.23	1.67	0.75	938
29	22	2.73	1.72	0.63	880	2.55	1.61	0.63	930	2.46	1.55	0.63	946	2.38	1.50	0.63	963
29	24	2.88	1.47	0.51	913	2.70	1.38	0.51	955	2.63	1.34	0.51	975	2.55	1.30	0.51	996
29	26	3.03	1.18	0.39	946	2.85	1.11	0.39	988	2.76	1.08	0.39	1008	2.68	1.04	0.39	1029
30	18	2.45	2.23	0.91	813	2.25	2.05	0.91	863	2.16	1.97	0.91	880	2.08	1.89	0.91	896
30	20	2.58	2.03	0.79	847	2.40	1.90	0.79	888	2.31	1.83	0.79	913	2.23	1.76	0.79	938
30	22	2.73	1.83	0.67	880	2.55	1.71	0.67	930	2.46	1.65	0.67	946	2.38	1.59	0.67	963
30	24	2.88	1.58	0.55	913	2.70	1.49	0.55	955	2.63	1.44	0.55	975	2.55	1.40	0.55	996
30	26	3.03	1.30	0.43	946	2.85	1.23	0.43	988	2.76	1.19	0.43	1008	2.68	1.15	0.43	1029
31	18	2.45	2.33	0.95	813	2.25	2.14	0.95	863	2.16	2.05	0.95	880	2.08	1.97	0.95	896
31	20	2.58	2.14	0.83	847	2.40	1.99	0.83	888	2.31	1.92	0.83	913	2.23	1.85	0.83	938
31	22	2.73	1.93	0.71	880	2.55	1.81	0.71	930	2.46	1.75	0.71	946	2.38	1.69	0.71	963
31	24	2.88	1.70	0.59	913	2.70	1.59	0.59	955	2.63	1.55	0.59	975	2.55	1.50	0.59	996
31	26	3.03	1.42	0.47	946	2.85	1.34	0.47	988	2.76	1.30	0.47	1008	2.68	1.26	0.47	1029
32	18	2.45	2.43	0.99	813	2.25	2.23	0.99	863	2.16	2.14	0.99	880	2.08	2.05	0.99	896
32	20	2.58	2.24	0.87	847	2.40	2.09	0.87	888	2.31	2.01	0.87	913	2.23	1.94	0.87	938
32	22	2.73	2.04	0.75	880	2.55	1.91	0.75	930	2.46	1.85	0.75	946	2.38	1.78	0.75	963
32	24	2.88	1.81	0.63	913	2.70	1.70	0.63	955	2.63	1.65	0.63	975	2.55	1.61	0.63	996
32	26	3.03	1.54	0.51	946	2.85	1.45	0.51	988	2.76	1.41	0.51	1008	2.68	1.36	0.51	1029

NOTE Q : Total capacity (kW) SHF : Sensible heat factor DB : Dry-bulb temperature
 SHC : Sensible heat capacity (kW) INPUT : Total power input (W) WB : Wet-bulb temperature

PERFORMANCE DATA COOL operation
MSC-C12TV -E1 : MU-C12TV -E1

CAPACITY: 3.55(KW) SHF: 0.69 INPUT: 1370(W)

INDOOR DB(°C)	INDOOR WB(°C)	OUTDOOR DB(°C)															
		21				25				27				30			
		Q	SHC	SHF	INPUT	Q	SHC	SHF	INPUT	Q	SHC	SHF	INPUT	Q	SHC	SHF	INPUT
21	18	4.17	2.13	0.51	1096	3.99	2.04	0.51	1151	3.83	1.96	0.51	1206	3.69	1.88	0.51	1260
21	20	4.35	1.70	0.39	1151	4.17	1.63	0.39	1219	4.05	1.58	0.39	1247	3.91	1.52	0.39	1302
22	18	4.17	2.29	0.55	1096	3.99	2.20	0.55	1151	3.83	2.11	0.55	1206	3.69	2.03	0.55	1260
22	20	4.35	1.87	0.43	1151	4.17	1.79	0.43	1219	4.05	1.74	0.43	1247	3.91	1.68	0.43	1302
22	22	4.53	1.40	0.31	1192	4.37	1.35	0.31	1267	4.26	1.32	0.31	1302	4.08	1.27	0.31	1356
23	18	4.17	2.46	0.59	1096	3.99	2.36	0.59	1151	3.83	2.26	0.59	1206	3.69	2.18	0.59	1260
23	20	4.35	2.04	0.47	1151	4.17	1.96	0.47	1219	4.05	1.90	0.47	1247	3.91	1.84	0.47	1302
23	22	4.53	1.58	0.35	1192	4.37	1.53	0.35	1267	4.26	1.49	0.35	1302	4.08	1.43	0.35	1356
24	18	4.17	2.63	0.63	1096	3.99	2.52	0.63	1151	3.83	2.42	0.63	1206	3.69	2.33	0.63	1260
24	20	4.35	2.22	0.51	1151	4.17	2.13	0.51	1219	4.05	2.06	0.51	1247	3.91	1.99	0.51	1302
24	22	4.53	1.77	0.39	1192	4.37	1.70	0.39	1267	4.26	1.66	0.39	1302	4.08	1.59	0.39	1356
24	24	4.76	1.28	0.27	1247	4.58	1.24	0.27	1315	4.47	1.21	0.27	1356	4.33	1.17	0.27	1425
25	18	4.17	2.79	0.67	1096	3.99	2.68	0.67	1151	3.83	2.57	0.67	1206	3.69	2.47	0.67	1260
25	20	4.35	2.39	0.55	1151	4.17	2.29	0.55	1219	4.05	2.23	0.55	1247	3.91	2.15	0.55	1302
25	22	4.53	1.95	0.43	1192	4.37	1.88	0.43	1267	4.26	1.83	0.43	1302	4.08	1.76	0.43	1356
25	24	4.76	1.47	0.31	1247	4.58	1.42	0.31	1315	4.47	1.39	0.31	1356	4.33	1.34	0.31	1425
26	18	4.17	2.96	0.71	1096	3.99	2.84	0.71	1151	3.83	2.72	0.71	1206	3.69	2.62	0.71	1260
26	20	4.35	2.57	0.59	1151	4.17	2.46	0.59	1219	4.05	2.39	0.59	1247	3.91	2.30	0.59	1302
26	22	4.53	2.13	0.47	1192	4.37	2.05	0.47	1267	4.26	2.00	0.47	1302	4.08	1.92	0.47	1356
26	24	4.76	1.66	0.35	1247	4.58	1.60	0.35	1315	4.47	1.57	0.35	1356	4.33	1.52	0.35	1425
26	26	4.90	1.13	0.23	1315	4.76	1.09	0.23	1384	4.69	1.08	0.23	1425	4.54	1.05	0.23	1466
27	18	4.17	3.13	0.75	1096	3.99	3.00	0.75	1151	3.83	2.88	0.75	1206	3.69	2.77	0.75	1260
27	20	4.35	2.74	0.63	1151	4.17	2.63	0.63	1219	4.05	2.55	0.63	1247	3.91	2.46	0.63	1302
27	22	4.53	2.31	0.51	1192	4.37	2.23	0.51	1267	4.26	2.17	0.51	1302	4.08	2.08	0.51	1356
27	24	4.76	1.86	0.39	1247	4.58	1.79	0.39	1315	4.47	1.74	0.39	1356	4.33	1.69	0.39	1425
27	26	4.90	1.32	0.27	1315	4.76	1.28	0.27	1384	4.69	1.27	0.27	1425	4.54	1.23	0.27	1466
28	18	4.17	3.30	0.79	1096	3.99	3.16	0.79	1151	3.83	3.03	0.79	1206	3.69	2.92	0.79	1260
28	20	4.35	2.91	0.67	1151	4.17	2.79	0.67	1219	4.05	2.71	0.67	1247	3.91	2.62	0.67	1302
28	22	4.53	2.49	0.55	1192	4.37	2.40	0.55	1267	4.26	2.34	0.55	1302	4.08	2.25	0.55	1356
28	24	4.76	2.05	0.43	1247	4.58	1.97	0.43	1315	4.47	1.92	0.43	1356	4.33	1.86	0.43	1425
28	26	4.90	1.52	0.31	1315	4.76	1.47	0.31	1384	4.69	1.45	0.31	1425	4.54	1.41	0.31	1466
29	18	4.17	3.46	0.83	1096	3.99	3.31	0.83	1151	3.83	3.18	0.83	1206	3.69	3.06	0.83	1260
29	20	4.35	3.09	0.71	1151	4.17	2.96	0.71	1219	4.05	2.87	0.71	1247	3.91	2.77	0.71	1302
29	22	4.53	2.67	0.59	1192	4.37	2.58	0.59	1267	4.26	2.51	0.59	1302	4.08	2.41	0.59	1356
29	24	4.76	2.24	0.47	1247	4.58	2.15	0.47	1315	4.47	2.10	0.47	1356	4.33	2.04	0.47	1425
29	26	4.90	1.71	0.35	1315	4.76	1.66	0.35	1384	4.69	1.64	0.35	1425	4.54	1.59	0.35	1466
30	18	4.17	3.63	0.87	1096	3.99	3.47	0.87	1151	3.83	3.34	0.87	1206	3.69	3.21	0.87	1260
30	20	4.35	3.26	0.75	1151	4.17	3.13	0.75	1219	4.05	3.04	0.75	1247	3.91	2.93	0.75	1302
30	22	4.53	2.85	0.63	1192	4.37	2.75	0.63	1267	4.26	2.68	0.63	1302	4.08	2.57	0.63	1356
30	24	4.76	2.43	0.51	1247	4.58	2.34	0.51	1315	4.47	2.28	0.51	1356	4.33	2.21	0.51	1425
30	26	4.90	1.91	0.39	1315	4.76	1.86	0.39	1384	4.69	1.83	0.39	1425	4.54	1.77	0.39	1466
31	18	4.17	3.80	0.91	1096	3.99	3.63	0.91	1151	3.83	3.49	0.91	1206	3.69	3.36	0.91	1260
31	20	4.35	3.44	0.79	1151	4.17	3.30	0.79	1219	4.05	3.20	0.79	1247	3.91	3.08	0.79	1302
31	22	4.53	3.03	0.67	1192	4.37	2.93	0.67	1267	4.26	2.85	0.67	1302	4.08	2.74	0.67	1356
31	24	4.76	2.62	0.55	1247	4.58	2.52	0.55	1315	4.47	2.46	0.55	1356	4.33	2.38	0.55	1425
31	26	4.90	2.11	0.43	1315	4.76	2.05	0.43	1384	4.69	2.01	0.43	1425	4.54	1.95	0.43	1466
32	18	4.17	3.96	0.95	1096	3.99	3.79	0.95	1151	3.83	3.64	0.95	1206	3.69	3.51	0.95	1260
32	20	4.35	3.61	0.83	1151	4.17	3.46	0.83	1219	4.05	3.36	0.83	1247	3.91	3.24	0.83	1302
32	22	4.53	3.21	0.71	1192	4.37	3.10	0.71	1267	4.26	3.02	0.71	1302	4.08	2.90	0.71	1356
32	24	4.76	2.81	0.59	1247	4.58	2.70	0.59	1315	4.47	2.64	0.59	1356	4.33	2.56	0.59	1425
32	26	4.90	2.30	0.47	1315	4.76	2.24	0.47	1384	4.69	2.20	0.47	1425	4.54	2.14	0.47	1466

NOTE Q : Total capacity (kW) SHF : Sensible heat factor DB : Dry-bulb temperature
SHC : Sensible heat capacity (kW) INPUT : Total power input (W) WB : Wet-bulb temperature

PERFORMANCE DATA COOL operation
MSC-C12TV -E1 : MU-C12TV -E1

CAPACITY: 3.55(KW) SHF: 0.69 INPUT: 1370(W)

INDOOR DB(°C)	INDOOR WB(°C)	OUTDOOR DB(°C)															
		35				40				43				46			
		Q	SHC	SHF	INPUT	Q	SHC	SHF	INPUT	Q	SHC	SHF	INPUT	Q	SHC	SHF	INPUT
21	18	3.48	1.77	0.51	1343	3.20	1.63	0.51	1425	3.07	1.57	0.51	1452	2.95	1.50	0.51	1480
21	20	3.66	1.43	0.39	1397	3.41	1.33	0.39	1466	3.28	1.28	0.39	1507	3.16	1.23	0.39	1548
22	18	3.48	1.91	0.55	1343	3.20	1.76	0.55	1425	3.07	1.69	0.55	1452	2.95	1.62	0.55	1480
22	20	3.66	1.57	0.43	1397	3.41	1.47	0.43	1466	3.28	1.41	0.43	1507	3.16	1.36	0.43	1548
22	22	3.87	1.20	0.31	1452	3.62	1.12	0.31	1534	3.50	1.08	0.31	1562	3.37	1.05	0.31	1589
23	18	3.48	2.05	0.59	1343	3.20	1.89	0.59	1425	3.07	1.81	0.59	1452	2.95	1.74	0.59	1480
23	20	3.66	1.72	0.47	1397	3.41	1.60	0.47	1466	3.28	1.54	0.47	1507	3.16	1.48	0.47	1548
23	22	3.87	1.35	0.35	1452	3.62	1.27	0.35	1534	3.50	1.22	0.35	1562	3.37	1.18	0.35	1589
24	18	3.48	2.19	0.63	1343	3.20	2.01	0.63	1425	3.07	1.93	0.63	1452	2.95	1.86	0.63	1480
24	20	3.66	1.86	0.51	1397	3.41	1.74	0.51	1466	3.28	1.67	0.51	1507	3.16	1.61	0.51	1548
24	22	3.87	1.51	0.39	1452	3.62	1.41	0.39	1534	3.50	1.36	0.39	1562	3.37	1.32	0.39	1589
24	24	4.08	1.10	0.27	1507	3.83	1.04	0.27	1576	3.73	1.01	0.27	1610	3.62	0.98	0.27	1644
25	18	3.48	2.33	0.67	1343	3.20	2.14	0.67	1425	3.07	2.06	0.67	1452	2.95	1.97	0.67	1480
25	20	3.66	2.01	0.55	1397	3.41	1.87	0.55	1466	3.28	1.81	0.55	1507	3.16	1.74	0.55	1548
25	22	3.87	1.66	0.43	1452	3.62	1.56	0.43	1534	3.50	1.50	0.43	1562	3.37	1.45	0.43	1589
25	24	4.08	1.27	0.31	1507	3.83	1.19	0.31	1576	3.73	1.16	0.31	1610	3.62	1.12	0.31	1644
26	18	3.48	2.47	0.71	1343	3.20	2.27	0.71	1425	3.07	2.18	0.71	1452	2.95	2.09	0.71	1480
26	20	3.66	2.16	0.59	1397	3.41	2.01	0.59	1466	3.28	1.94	0.59	1507	3.16	1.86	0.59	1548
26	22	3.87	1.82	0.47	1452	3.62	1.70	0.47	1534	3.50	1.64	0.47	1562	3.37	1.59	0.47	1589
26	24	4.08	1.43	0.35	1507	3.83	1.34	0.35	1576	3.73	1.30	0.35	1610	3.62	1.27	0.35	1644
26	26	4.30	0.99	0.23	1562	4.05	0.93	0.23	1630	3.92	0.90	0.23	1665	3.80	0.87	0.23	1699
27	18	3.48	2.61	0.75	1343	3.20	2.40	0.75	1425	3.07	2.30	0.75	1452	2.95	2.21	0.75	1480
27	20	3.66	2.30	0.63	1397	3.41	2.15	0.63	1466	3.28	2.07	0.63	1507	3.16	1.99	0.63	1548
27	22	3.87	1.97	0.51	1452	3.62	1.85	0.51	1534	3.50	1.78	0.51	1562	3.37	1.72	0.51	1589
27	24	4.08	1.59	0.39	1507	3.83	1.50	0.39	1576	3.73	1.45	0.39	1610	3.62	1.41	0.39	1644
27	26	4.30	1.16	0.27	1562	4.05	1.09	0.27	1630	3.92	1.06	0.27	1665	3.80	1.03	0.27	1699
28	18	3.48	2.75	0.79	1343	3.20	2.52	0.79	1425	3.07	2.43	0.79	1452	2.95	2.33	0.79	1480
28	20	3.66	2.45	0.67	1397	3.41	2.28	0.67	1466	3.28	2.20	0.67	1507	3.16	2.12	0.67	1548
28	22	3.87	2.13	0.55	1452	3.62	1.99	0.55	1534	3.50	1.92	0.55	1562	3.37	1.85	0.55	1589
28	24	4.08	1.76	0.43	1507	3.83	1.65	0.43	1576	3.73	1.60	0.43	1610	3.62	1.56	0.43	1644
28	26	4.30	1.33	0.31	1562	4.05	1.25	0.31	1630	3.92	1.22	0.31	1665	3.80	1.18	0.31	1699
29	18	3.48	2.89	0.83	1343	3.20	2.65	0.83	1425	3.07	2.55	0.83	1452	2.95	2.45	0.83	1480
29	20	3.66	2.60	0.71	1397	3.41	2.42	0.71	1466	3.28	2.33	0.71	1507	3.16	2.24	0.71	1548
29	22	3.87	2.28	0.59	1452	3.62	2.14	0.59	1534	3.50	2.06	0.59	1562	3.37	1.99	0.59	1589
29	24	4.08	1.92	0.47	1507	3.83	1.80	0.47	1576	3.73	1.75	0.47	1610	3.62	1.70	0.47	1644
29	26	4.30	1.50	0.35	1562	4.05	1.42	0.35	1630	3.92	1.37	0.35	1665	3.80	1.33	0.35	1699
30	18	3.48	3.03	0.87	1343	3.20	2.78	0.87	1425	3.07	2.67	0.87	1452	2.95	2.56	0.87	1480
30	20	3.66	2.74	0.75	1397	3.41	2.56	0.75	1466	3.28	2.46	0.75	1507	3.16	2.37	0.75	1548
30	22	3.87	2.44	0.63	1452	3.62	2.28	0.63	1534	3.50	2.20	0.63	1562	3.37	2.12	0.63	1589
30	24	4.08	2.08	0.51	1507	3.83	1.96	0.51	1576	3.73	1.90	0.51	1610	3.62	1.85	0.51	1644
30	26	4.30	1.68	0.39	1562	4.05	1.58	0.39	1630	3.92	1.53	0.39	1665	3.80	1.48	0.39	1699
31	18	3.48	3.17	0.91	1343	3.20	2.91	0.91	1425	3.07	2.79	0.91	1452	2.95	2.68	0.91	1480
31	20	3.66	2.89	0.79	1397	3.41	2.69	0.79	1466	3.28	2.59	0.79	1507	3.16	2.50	0.79	1548
31	22	3.87	2.59	0.67	1452	3.62	2.43	0.67	1534	3.50	2.34	0.67	1562	3.37	2.26	0.67	1589
31	24	4.08	2.25	0.55	1507	3.83	2.11	0.55	1576	3.73	2.05	0.55	1610	3.62	1.99	0.55	1644
31	26	4.30	1.85	0.43	1562	4.05	1.74	0.43	1630	3.92	1.69	0.43	1665	3.80	1.63	0.43	1699
32	18	3.48	3.31	0.95	1343	3.20	3.04	0.95	1425	3.07	2.92	0.95	1452	2.95	2.80	0.95	1480
32	20	3.66	3.03	0.83	1397	3.41	2.83	0.83	1466	3.28	2.73	0.83	1507	3.16	2.62	0.83	1548
32	22	3.87	2.75	0.71	1452	3.62	2.57	0.71	1534	3.50	2.48	0.71	1562	3.37	2.39	0.71	1589
32	24	4.08	2.41	0.59	1507	3.83	2.26	0.59	1576	3.73	2.20	0.59	1610	3.62	2.14	0.59	1644
32	26	4.30	2.02	0.47	1562	4.05	1.90	0.47	1630	3.92	1.84	0.47	1665	3.80	1.79	0.47	1699

NOTE Q : Total capacity (kW) SHF : Sensible heat factor DB : Dry-bulb temperature
 SHC : Sensible heat capacity (kW) INPUT : Total power input (W) WB : Wet-bulb temperature

PERFORMANCE DATA COOL operation
MSC-C07TV -E1 : MUH-C07TV -E1

CAPACITY: 2.20(KW) SHF: 0.77 INPUT: 770(W)

		OUTDOOR DB(°C)															
INDOOR DB(°C)	INDOOR WB(°C)	21				25				27				30			
		Q	SHC	SHF	INPUT	Q	SHC	SHF	INPUT	Q	SHC	SHF	INPUT	Q	SHC	SHF	INPUT
21	18	2.59	1.53	0.59	616	2.48	1.46	0.59	647	2.38	1.40	0.59	678	2.29	1.35	0.59	708
21	20	2.70	1.27	0.47	647	2.59	1.21	0.47	685	2.51	1.18	0.47	701	2.42	1.14	0.47	732
22	18	2.59	1.63	0.63	616	2.48	1.56	0.63	647	2.38	1.50	0.63	678	2.29	1.44	0.63	708
22	20	2.70	1.37	0.51	647	2.59	1.32	0.51	685	2.51	1.28	0.51	701	2.42	1.23	0.51	732
22	22	2.81	1.09	0.39	670	2.71	1.06	0.39	712	2.64	1.03	0.39	732	2.53	0.99	0.39	762
23	18	2.59	1.73	0.67	616	2.48	1.66	0.67	647	2.38	1.59	0.67	678	2.29	1.53	0.67	708
23	20	2.70	1.48	0.55	647	2.59	1.42	0.55	685	2.51	1.38	0.55	701	2.42	1.33	0.55	732
23	22	2.81	1.21	0.43	670	2.71	1.16	0.43	712	2.64	1.14	0.43	732	2.53	1.09	0.43	762
24	18	2.59	1.84	0.71	616	2.48	1.76	0.71	647	2.38	1.69	0.71	678	2.29	1.62	0.71	708
24	20	2.70	1.59	0.59	647	2.59	1.53	0.59	685	2.51	1.48	0.59	701	2.42	1.43	0.59	732
24	22	2.81	1.32	0.47	670	2.71	1.27	0.47	712	2.64	1.24	0.47	732	2.53	1.19	0.47	762
24	24	2.95	1.03	0.35	701	2.84	0.99	0.35	739	2.77	0.97	0.35	762	2.68	0.94	0.35	801
25	18	2.59	1.94	0.75	616	2.48	1.86	0.75	647	2.38	1.78	0.75	678	2.29	1.72	0.75	708
25	20	2.70	1.70	0.63	647	2.59	1.63	0.63	685	2.51	1.58	0.63	701	2.42	1.52	0.63	732
25	22	2.81	1.43	0.51	670	2.71	1.38	0.51	712	2.64	1.35	0.51	732	2.53	1.29	0.51	762
25	24	2.95	1.15	0.39	701	2.84	1.11	0.39	739	2.77	1.08	0.39	762	2.68	1.05	0.39	801
26	18	2.59	2.04	0.79	616	2.48	1.96	0.79	647	2.38	1.88	0.79	678	2.29	1.81	0.79	708
26	20	2.70	1.81	0.67	647	2.59	1.73	0.67	685	2.51	1.68	0.67	701	2.42	1.62	0.67	732
26	22	2.81	1.54	0.55	670	2.71	1.49	0.55	712	2.64	1.45	0.55	732	2.53	1.39	0.55	762
26	24	2.95	1.27	0.43	701	2.84	1.22	0.43	739	2.77	1.19	0.43	762	2.68	1.15	0.43	801
26	26	3.04	0.94	0.31	739	2.95	0.91	0.31	778	2.90	0.90	0.31	801	2.82	0.87	0.31	824
27	18	2.59	2.15	0.83	616	2.48	2.05	0.83	647	2.38	1.97	0.83	678	2.29	1.90	0.83	708
27	20	2.70	1.91	0.71	647	2.59	1.84	0.71	685	2.51	1.78	0.71	701	2.42	1.72	0.71	732
27	22	2.81	1.65	0.59	670	2.71	1.60	0.59	712	2.64	1.56	0.59	732	2.53	1.49	0.59	762
27	24	2.95	1.39	0.47	701	2.84	1.33	0.47	739	2.77	1.30	0.47	762	2.68	1.26	0.47	801
27	26	3.04	1.06	0.35	739	2.95	1.03	0.35	778	2.90	1.02	0.35	801	2.82	0.99	0.35	824
28	18	2.59	2.25	0.87	616	2.48	2.15	0.87	647	2.38	2.07	0.87	678	2.29	1.99	0.87	708
28	20	2.70	2.02	0.75	647	2.59	1.94	0.75	685	2.51	1.88	0.75	701	2.42	1.82	0.75	732
28	22	2.81	1.77	0.63	670	2.71	1.70	0.63	712	2.64	1.66	0.63	732	2.53	1.59	0.63	762
28	24	2.95	1.50	0.51	701	2.84	1.45	0.51	739	2.77	1.41	0.51	762	2.68	1.37	0.51	801
28	26	3.04	1.18	0.39	739	2.95	1.15	0.39	778	2.90	1.13	0.39	801	2.82	1.10	0.39	824
29	18	2.59	2.35	0.91	616	2.48	2.25	0.91	647	2.38	2.16	0.91	678	2.29	2.08	0.91	708
29	20	2.70	2.13	0.79	647	2.59	2.04	0.79	685	2.51	1.98	0.79	701	2.42	1.91	0.79	732
29	22	2.81	1.88	0.67	670	2.71	1.81	0.67	712	2.64	1.77	0.67	732	2.53	1.70	0.67	762
29	24	2.95	1.62	0.55	701	2.84	1.56	0.55	739	2.77	1.52	0.55	762	2.68	1.48	0.55	801
29	26	3.04	1.31	0.43	739	2.95	1.27	0.43	778	2.90	1.25	0.43	801	2.82	1.21	0.43	824
30	18	2.59	2.46	0.95	616	2.48	2.35	0.95	647	2.38	2.26	0.95	678	2.29	2.17	0.95	708
30	20	2.70	2.24	0.83	647	2.59	2.15	0.83	685	2.51	2.08	0.83	701	2.42	2.01	0.83	732
30	22	2.81	1.99	0.71	670	2.71	1.92	0.71	712	2.64	1.87	0.71	732	2.53	1.80	0.71	762
30	24	2.95	1.74	0.59	701	2.84	1.67	0.59	739	2.77	1.64	0.59	762	2.68	1.58	0.59	801
30	26	3.04	1.43	0.47	739	2.95	1.39	0.47	778	2.90	1.36	0.47	801	2.82	1.32	0.47	824
31	18	2.59	2.56	0.99	616	2.48	2.45	0.99	647	2.38	2.35	0.99	678	2.29	2.27	0.99	708
31	20	2.70	2.34	0.87	647	2.59	2.25	0.87	685	2.51	2.18	0.87	701	2.42	2.11	0.87	732
31	22	2.81	2.10	0.75	670	2.71	2.03	0.75	712	2.64	1.98	0.75	732	2.53	1.90	0.75	762
31	24	2.95	1.86	0.63	701	2.84	1.79	0.63	739	2.77	1.75	0.63	762	2.68	1.69	0.63	801
31	26	3.04	1.55	0.51	739	2.95	1.50	0.51	778	2.90	1.48	0.51	801	2.82	1.44	0.51	824
32	18	2.59	2.66	1.03	616	2.48	2.55	1.03	647	2.38	2.45	1.03	678	2.29	2.36	1.03	708
32	20	2.70	2.45	0.91	647	2.59	2.35	0.91	685	2.51	2.28	0.91	701	2.42	2.20	0.91	732
32	22	2.81	2.22	0.79	670	2.71	2.14	0.79	712	2.64	2.09	0.79	732	2.53	2.00	0.79	762
32	24	2.95	1.98	0.67	701	2.84	1.90	0.67	739	2.77	1.86	0.67	762	2.68	1.80	0.67	801
32	26	3.04	1.67	0.55	739	2.95	1.62	0.55	778	2.90	1.60	0.55	801	2.82	1.55	0.55	824

NOTE Q : Total capacity (kW) SHF : Sensible heat factor DB : Dry-bulb temperature
SHC : Sensible heat capacity (kW) INPUT : Total power input (W) WB : Wet-bulb temperature

PERFORMANCE DATA COOL operation

MSC-C07TV -[E1] : MUH-C07TV -[E1]

CAPACITY: 2.20(KW) SHF: 0.77 INPUT: 770(W)

		OUTDOOR DB(°C)															
INDOOR DB(°C)	INDOOR WB(°C)	35				40				43				46			
		Q	SHC	SHF	INPUT	Q	SHC	SHF	INPUT	Q	SHC	SHF	INPUT	Q	SHC	SHF	INPUT
21	18	2.16	1.27	0.59	755	1.98	1.17	0.59	801	1.90	1.12	0.59	816	1.83	1.08	0.59	832
21	20	2.27	1.07	0.47	785	2.11	0.99	0.47	824	2.04	0.96	0.47	847	1.96	0.92	0.47	870
22	18	2.16	1.36	0.63	755	1.98	1.25	0.63	801	1.90	1.20	0.63	816	1.83	1.15	0.63	832
22	20	2.27	1.16	0.51	785	2.11	1.08	0.51	824	2.04	1.04	0.51	847	1.96	1.00	0.51	870
22	22	2.40	0.94	0.39	816	2.24	0.88	0.39	862	2.17	0.85	0.39	878	2.09	0.82	0.39	893
23	18	2.16	1.44	0.67	755	1.98	1.33	0.67	801	1.90	1.28	0.67	816	1.83	1.22	0.67	832
23	20	2.27	1.25	0.55	785	2.11	1.16	0.55	824	2.04	1.12	0.55	847	1.96	1.08	0.55	870
23	22	2.40	1.03	0.43	816	2.24	0.96	0.43	862	2.17	0.93	0.43	878	2.09	0.90	0.43	893
24	18	2.16	1.53	0.71	755	1.98	1.41	0.71	801	1.90	1.35	0.71	816	1.83	1.30	0.71	832
24	20	2.27	1.34	0.59	785	2.11	1.25	0.59	824	2.04	1.20	0.59	847	1.96	1.16	0.59	870
24	22	2.40	1.13	0.47	816	2.24	1.05	0.47	862	2.17	1.02	0.47	878	2.09	0.98	0.47	893
24	24	2.53	0.89	0.35	847	2.38	0.83	0.35	886	2.31	0.81	0.35	905	2.24	0.79	0.35	924
25	18	2.16	1.62	0.75	755	1.98	1.49	0.75	801	1.90	1.43	0.75	816	1.83	1.37	0.75	832
25	20	2.27	1.43	0.63	785	2.11	1.33	0.63	824	2.04	1.28	0.63	847	1.96	1.23	0.63	870
25	22	2.40	1.22	0.51	816	2.24	1.14	0.51	862	2.17	1.11	0.51	878	2.09	1.07	0.51	893
25	24	2.53	0.99	0.39	847	2.38	0.93	0.39	886	2.31	0.90	0.39	905	2.24	0.88	0.39	924
26	18	2.16	1.70	0.79	755	1.98	1.56	0.79	801	1.90	1.50	0.79	816	1.83	1.44	0.79	832
26	20	2.27	1.52	0.67	785	2.11	1.42	0.67	824	2.04	1.36	0.67	847	1.96	1.31	0.67	870
26	22	2.40	1.32	0.55	816	2.24	1.23	0.55	862	2.17	1.19	0.55	878	2.09	1.15	0.55	893
26	24	2.53	1.09	0.43	847	2.38	1.02	0.43	886	2.31	0.99	0.43	905	2.24	0.96	0.43	924
26	26	2.66	0.83	0.31	878	2.51	0.78	0.31	916	2.43	0.75	0.31	936	2.35	0.73	0.31	955
27	18	2.16	1.79	0.83	755	1.98	1.64	0.83	801	1.90	1.58	0.83	816	1.83	1.52	0.83	832
27	20	2.27	1.61	0.71	785	2.11	1.50	0.71	824	2.04	1.44	0.71	847	1.96	1.39	0.71	870
27	22	2.40	1.41	0.59	816	2.24	1.32	0.59	862	2.17	1.28	0.59	878	2.09	1.23	0.59	893
27	24	2.53	1.19	0.47	847	2.38	1.12	0.47	886	2.31	1.09	0.47	905	2.24	1.05	0.47	924
27	26	2.66	0.93	0.35	878	2.51	0.88	0.35	916	2.43	0.85	0.35	936	2.35	0.82	0.35	955
28	18	2.16	1.88	0.87	755	1.98	1.72	0.87	801	1.90	1.66	0.87	816	1.83	1.59	0.87	832
28	20	2.27	1.70	0.75	785	2.11	1.58	0.75	824	2.04	1.53	0.75	847	1.96	1.47	0.75	870
28	22	2.40	1.51	0.63	816	2.24	1.41	0.63	862	2.17	1.37	0.63	878	2.09	1.32	0.63	893
28	24	2.53	1.29	0.51	847	2.38	1.21	0.51	886	2.31	1.18	0.51	905	2.24	1.14	0.51	924
28	26	2.66	1.04	0.39	878	2.51	0.98	0.39	916	2.43	0.95	0.39	936	2.35	0.92	0.39	955
29	18	2.16	1.96	0.91	755	1.98	1.80	0.91	801	1.90	1.73	0.91	816	1.83	1.66	0.91	832
29	20	2.27	1.79	0.79	785	2.11	1.67	0.79	824	2.04	1.61	0.79	847	1.96	1.55	0.79	870
29	22	2.40	1.61	0.67	816	2.24	1.50	0.67	862	2.17	1.45	0.67	878	2.09	1.40	0.67	893
29	24	2.53	1.39	0.55	847	2.38	1.31	0.55	886	2.31	1.27	0.55	905	2.24	1.23	0.55	924
29	26	2.66	1.14	0.43	878	2.51	1.08	0.43	916	2.43	1.05	0.43	936	2.35	1.01	0.43	955
30	18	2.16	2.05	0.95	755	1.98	1.88	0.95	801	1.90	1.81	0.95	816	1.83	1.73	0.95	832
30	20	2.27	1.88	0.83	785	2.11	1.75	0.83	824	2.04	1.69	0.83	847	1.96	1.63	0.83	870
30	22	2.40	1.70	0.71	816	2.24	1.59	0.71	862	2.17	1.54	0.71	878	2.09	1.48	0.71	893
30	24	2.53	1.49	0.59	847	2.38	1.40	0.59	886	2.31	1.36	0.59	905	2.24	1.32	0.59	924
30	26	2.66	1.25	0.47	878	2.51	1.18	0.47	916	2.43	1.14	0.47	936	2.35	1.11	0.47	955
31	18	2.16	2.13	0.99	755	1.98	1.96	0.99	801	1.90	1.88	0.99	816	1.83	1.81	0.99	832
31	20	2.27	1.97	0.87	785	2.11	1.84	0.87	824	2.04	1.77	0.87	847	1.96	1.70	0.87	870
31	22	2.40	1.80	0.75	816	2.24	1.68	0.75	862	2.17	1.63	0.75	878	2.09	1.57	0.75	893
31	24	2.53	1.59	0.63	847	2.38	1.50	0.63	886	2.31	1.46	0.63	905	2.24	1.41	0.63	924
31	26	2.66	1.36	0.51	878	2.51	1.28	0.51	916	2.43	1.24	0.51	936	2.35	1.20	0.51	955
32	18	2.16	2.22	1.03	755	1.98	2.04	1.03	801	1.90	1.96	1.03	816	1.83	1.88	1.03	832
32	20	2.27	2.06	0.91	785	2.11	1.92	0.91	824	2.04	1.85	0.91	847	1.96	1.78	0.91	870
32	22	2.40	1.89	0.79	816	2.24	1.77	0.79	862	2.17	1.71	0.79	878	2.09	1.65	0.79	893
32	24	2.53	1.70	0.67	847	2.38	1.59	0.67	886	2.31	1.55	0.67	905	2.24	1.50	0.67	924
32	26	2.66	1.46	0.55	878	2.51	1.38	0.55	916	2.43	1.34	0.55	936	2.35	1.29	0.55	955

NOTE Q : Total capacity (kW) SHF : Sensible heat factor DB : Dry-bulb temperature
 SHC : Sensible heat capacity (kW) INPUT : Total power input (W) WB : Wet-bulb temperature

PERFORMANCE DATA COOL operation
MSC-C09TV -E1 : MUH-C09TV -E1

CAPACITY: 2.55(KW) SHF: 0.72 INPUT: 910(W)

		OUTDOOR DB(°C)															
INDOOR DB(°C)	INDOOR WB(°C)	21				25				27				30			
		Q	SHC	SHF	INPUT	Q	SHC	SHF	INPUT	Q	SHC	SHF	INPUT	Q	SHC	SHF	INPUT
21	18	3.00	1.62	0.54	728	2.87	1.55	0.54	764	2.75	1.49	0.54	801	2.65	1.43	0.54	837
21	20	3.12	1.31	0.42	764	3.00	1.26	0.42	810	2.91	1.22	0.42	828	2.81	1.18	0.42	865
22	18	3.00	1.74	0.58	728	2.87	1.66	0.58	764	2.75	1.60	0.58	801	2.65	1.54	0.58	837
22	20	3.12	1.44	0.46	764	3.00	1.38	0.46	810	2.91	1.34	0.46	828	2.81	1.29	0.46	865
22	22	3.25	1.11	0.34	792	3.14	1.07	0.34	842	3.06	1.04	0.34	865	2.93	1.00	0.34	901
23	18	3.00	1.86	0.62	728	2.87	1.78	0.62	764	2.75	1.71	0.62	801	2.65	1.64	0.62	837
23	20	3.12	1.56	0.50	764	3.00	1.50	0.50	810	2.91	1.45	0.50	828	2.81	1.40	0.50	865
23	22	3.25	1.24	0.38	792	3.14	1.19	0.38	842	3.06	1.16	0.38	865	2.93	1.11	0.38	901
24	18	3.00	1.98	0.66	728	2.87	1.89	0.66	764	2.75	1.82	0.66	801	2.65	1.75	0.66	837
24	20	3.12	1.69	0.54	764	3.00	1.62	0.54	810	2.91	1.57	0.54	828	2.81	1.51	0.54	865
24	22	3.25	1.37	0.42	792	3.14	1.32	0.42	842	3.06	1.29	0.42	865	2.93	1.23	0.42	901
24	24	3.42	1.03	0.30	828	3.29	0.99	0.30	874	3.21	0.96	0.30	901	3.11	0.93	0.30	946
25	18	3.00	2.10	0.70	728	2.87	2.01	0.70	764	2.75	1.93	0.70	801	2.65	1.86	0.70	837
25	20	3.12	1.81	0.58	764	3.00	1.74	0.58	810	2.91	1.69	0.58	828	2.81	1.63	0.58	865
25	22	3.25	1.50	0.46	792	3.14	1.44	0.46	842	3.06	1.41	0.46	865	2.93	1.35	0.46	901
25	24	3.42	1.16	0.34	828	3.29	1.12	0.34	874	3.21	1.09	0.34	901	3.11	1.06	0.34	946
26	18	3.00	2.22	0.74	728	2.87	2.12	0.74	764	2.75	2.04	0.74	801	2.65	1.96	0.74	837
26	20	3.12	1.94	0.62	764	3.00	1.86	0.62	810	2.91	1.80	0.62	828	2.81	1.74	0.62	865
26	22	3.25	1.63	0.50	792	3.14	1.57	0.50	842	3.06	1.53	0.50	865	2.93	1.47	0.50	901
26	24	3.42	1.30	0.38	828	3.29	1.25	0.38	874	3.21	1.22	0.38	901	3.11	1.18	0.38	946
26	26	3.52	0.91	0.26	874	3.42	0.89	0.26	919	3.37	0.88	0.26	946	3.26	0.85	0.26	974
27	18	3.00	2.34	0.78	728	2.87	2.24	0.78	764	2.75	2.15	0.78	801	2.65	2.07	0.78	837
27	20	3.12	2.06	0.66	764	3.00	1.98	0.66	810	2.91	1.92	0.66	828	2.81	1.85	0.66	865
27	22	3.25	1.76	0.54	792	3.14	1.69	0.54	842	3.06	1.65	0.54	865	2.93	1.58	0.54	901
27	24	3.42	1.44	0.42	828	3.29	1.38	0.42	874	3.21	1.35	0.42	901	3.11	1.31	0.42	946
27	26	3.52	1.06	0.30	874	3.42	1.03	0.30	919	3.37	1.01	0.30	946	3.26	0.98	0.30	974
28	18	3.00	2.46	0.82	728	2.87	2.35	0.82	764	2.75	2.26	0.82	801	2.65	2.17	0.82	837
28	20	3.12	2.19	0.70	764	3.00	2.10	0.70	810	2.91	2.03	0.70	828	2.81	1.96	0.70	865
28	22	3.25	1.89	0.58	792	3.14	1.82	0.58	842	3.06	1.77	0.58	865	2.93	1.70	0.58	901
28	24	3.42	1.57	0.46	828	3.29	1.51	0.46	874	3.21	1.48	0.46	901	3.11	1.43	0.46	946
28	26	3.52	1.20	0.34	874	3.42	1.16	0.34	919	3.37	1.14	0.34	946	3.26	1.11	0.34	974
29	18	3.00	2.58	0.86	728	2.87	2.47	0.86	764	2.75	2.37	0.86	801	2.65	2.28	0.86	837
29	20	3.12	2.31	0.74	764	3.00	2.22	0.74	810	2.91	2.15	0.74	828	2.81	2.08	0.74	865
29	22	3.25	2.02	0.62	792	3.14	1.94	0.62	842	3.06	1.90	0.62	865	2.93	1.82	0.62	901
29	24	3.42	1.71	0.50	828	3.29	1.64	0.50	874	3.21	1.61	0.50	901	3.11	1.56	0.50	946
29	26	3.52	1.34	0.38	874	3.42	1.30	0.38	919	3.37	1.28	0.38	946	3.26	1.24	0.38	974
30	18	3.00	2.70	0.90	728	2.87	2.58	0.90	764	2.75	2.48	0.90	801	2.65	2.39	0.90	837
30	20	3.12	2.44	0.78	764	3.00	2.34	0.78	810	2.91	2.27	0.78	828	2.81	2.19	0.78	865
30	22	3.25	2.15	0.66	792	3.14	2.07	0.66	842	3.06	2.02	0.66	865	2.93	1.94	0.66	901
30	24	3.42	1.85	0.54	828	3.29	1.78	0.54	874	3.21	1.74	0.54	901	3.11	1.68	0.54	946
30	26	3.52	1.48	0.42	874	3.42	1.44	0.42	919	3.37	1.41	0.42	946	3.26	1.37	0.42	974
31	18	3.00	2.82	0.94	728	2.87	2.70	0.94	764	2.75	2.59	0.94	801	2.65	2.49	0.94	837
31	20	3.12	2.56	0.82	764	3.00	2.46	0.82	810	2.91	2.38	0.82	828	2.81	2.30	0.82	865
31	22	3.25	2.28	0.70	792	3.14	2.20	0.70	842	3.06	2.14	0.70	865	2.93	2.05	0.70	901
31	24	3.42	1.98	0.58	828	3.29	1.91	0.58	874	3.21	1.86	0.58	901	3.11	1.80	0.58	946
31	26	3.52	1.62	0.46	874	3.42	1.57	0.46	919	3.37	1.55	0.46	946	3.26	1.50	0.46	974
32	18	3.00	2.94	0.98	728	2.87	2.81	0.98	764	2.75	2.70	0.98	801	2.65	2.60	0.98	837
32	20	3.12	2.69	0.86	764	3.00	2.58	0.86	810	2.91	2.50	0.86	828	2.81	2.41	0.86	865
32	22	3.25	2.41	0.74	792	3.14	2.32	0.74	842	3.06	2.26	0.74	865	2.93	2.17	0.74	901
32	24	3.42	2.12	0.62	828	3.29	2.04	0.62	874	3.21	1.99	0.62	901	3.11	1.93	0.62	946
32	26	3.52	1.76	0.50	874	3.42	1.71	0.50	919	3.37	1.68	0.50	946	3.26	1.63	0.50	974

NOTE Q : Total capacity (kW) SHF : Sensible heat factor DB : Dry-bulb temperature
 SHC : Sensible heat capacity (kW) INPUT : Total power input (W) WB : Wet-bulb temperature

PERFORMANCE DATA COOL operation

MSC-C09TV -[E1] : MUH-C09TV -[E1]

CAPACITY: 2.55(KW) SHF: 0.72 INPUT: 910(W)

INDOOR DB(°C)	INDOOR WB(°C)	OUTDOOR DB(°C)															
		35				40				43				46			
		Q	SHC	SHF	INPUT	Q	SHC	SHF	INPUT	Q	SHC	SHF	INPUT	Q	SHC	SHF	INPUT
21	18	2.50	1.35	0.54	892	2.30	1.24	0.54	946	2.21	1.19	0.54	965	2.12	1.14	0.54	983
21	20	2.63	1.10	0.42	928	2.45	1.03	0.42	974	2.36	0.99	0.42	1001	2.27	0.95	0.42	1028
22	18	2.50	1.45	0.58	892	2.30	1.33	0.58	946	2.21	1.28	0.58	965	2.12	1.23	0.58	983
22	20	2.63	1.21	0.46	928	2.45	1.13	0.46	974	2.36	1.09	0.46	1001	2.27	1.04	0.46	1028
22	22	2.78	0.95	0.34	965	2.60	0.88	0.34	1019	2.51	0.85	0.34	1037	2.42	0.82	0.34	1056
23	18	2.50	1.55	0.62	892	2.30	1.42	0.62	946	2.21	1.37	0.62	965	2.12	1.31	0.62	983
23	20	2.63	1.31	0.50	928	2.45	1.22	0.50	974	2.36	1.18	0.50	1001	2.27	1.13	0.50	1028
23	22	2.78	1.06	0.38	965	2.60	0.99	0.38	1019	2.51	0.95	0.38	1037	2.42	0.92	0.38	1056
24	18	2.50	1.65	0.66	892	2.30	1.51	0.66	946	2.21	1.46	0.66	965	2.12	1.40	0.66	983
24	20	2.63	1.42	0.54	928	2.45	1.32	0.54	974	2.36	1.27	0.54	1001	2.27	1.23	0.54	1028
24	22	2.78	1.17	0.42	965	2.60	1.09	0.42	1019	2.51	1.05	0.42	1037	2.42	1.02	0.42	1056
24	24	2.93	0.88	0.30	1001	2.75	0.83	0.30	1047	2.68	0.80	0.30	1069	2.60	0.78	0.30	1092
25	18	2.50	1.75	0.70	892	2.30	1.61	0.70	946	2.21	1.54	0.70	965	2.12	1.48	0.70	983
25	20	2.63	1.52	0.58	928	2.45	1.42	0.58	974	2.36	1.37	0.58	1001	2.27	1.32	0.58	1028
25	22	2.78	1.28	0.46	965	2.60	1.20	0.46	1019	2.51	1.16	0.46	1037	2.42	1.11	0.46	1056
25	24	2.93	1.00	0.34	1001	2.75	0.94	0.34	1047	2.68	0.91	0.34	1069	2.60	0.88	0.34	1092
26	18	2.50	1.85	0.74	892	2.30	1.70	0.74	946	2.21	1.63	0.74	965	2.12	1.57	0.74	983
26	20	2.63	1.63	0.62	928	2.45	1.52	0.62	974	2.36	1.46	0.62	1001	2.27	1.41	0.62	1028
26	22	2.78	1.39	0.50	965	2.60	1.30	0.50	1019	2.51	1.26	0.50	1037	2.42	1.21	0.50	1056
26	24	2.93	1.11	0.38	1001	2.75	1.05	0.38	1047	2.68	1.02	0.38	1069	2.60	0.99	0.38	1092
26	26	3.09	0.80	0.26	1037	2.91	0.76	0.26	1083	2.82	0.73	0.26	1106	2.73	0.71	0.26	1128
27	18	2.50	1.95	0.78	892	2.30	1.79	0.78	946	2.21	1.72	0.78	965	2.12	1.65	0.78	983
27	20	2.63	1.73	0.66	928	2.45	1.62	0.66	974	2.36	1.56	0.66	1001	2.27	1.50	0.66	1028
27	22	2.78	1.50	0.54	965	2.60	1.40	0.54	1019	2.51	1.36	0.54	1037	2.42	1.31	0.54	1056
27	24	2.93	1.23	0.42	1001	2.75	1.16	0.42	1047	2.68	1.12	0.42	1069	2.60	1.09	0.42	1092
27	26	3.09	0.93	0.30	1037	2.91	0.87	0.30	1083	2.82	0.85	0.30	1106	2.73	0.82	0.30	1128
28	18	2.50	2.05	0.82	892	2.30	1.88	0.82	946	2.21	1.81	0.82	965	2.12	1.74	0.82	983
28	20	2.63	1.84	0.70	928	2.45	1.71	0.70	974	2.36	1.65	0.70	1001	2.27	1.59	0.70	1028
28	22	2.78	1.61	0.58	965	2.60	1.51	0.58	1019	2.51	1.46	0.58	1037	2.42	1.41	0.58	1056
28	24	2.93	1.35	0.46	1001	2.75	1.27	0.46	1047	2.68	1.23	0.46	1069	2.60	1.20	0.46	1092
28	26	3.09	1.05	0.34	1037	2.91	0.99	0.34	1083	2.82	0.96	0.34	1106	2.73	0.93	0.34	1128
29	18	2.50	2.15	0.86	892	2.30	1.97	0.86	946	2.21	1.90	0.86	965	2.12	1.82	0.86	983
29	20	2.63	1.94	0.74	928	2.45	1.81	0.74	974	2.36	1.75	0.74	1001	2.27	1.68	0.74	1028
29	22	2.78	1.72	0.62	965	2.60	1.61	0.62	1019	2.51	1.56	0.62	1037	2.42	1.50	0.62	1056
29	24	2.93	1.47	0.50	1001	2.75	1.38	0.50	1047	2.68	1.34	0.50	1069	2.60	1.30	0.50	1092
29	26	3.09	1.17	0.38	1037	2.91	1.10	0.38	1083	2.82	1.07	0.38	1106	2.73	1.04	0.38	1128
30	18	2.50	2.25	0.90	892	2.30	2.07	0.90	946	2.21	1.99	0.90	965	2.12	1.90	0.90	983
30	20	2.63	2.05	0.78	928	2.45	1.91	0.78	974	2.36	1.84	0.78	1001	2.27	1.77	0.78	1028
30	22	2.78	1.83	0.66	965	2.60	1.72	0.66	1019	2.51	1.66	0.66	1037	2.42	1.60	0.66	1056
30	24	2.93	1.58	0.54	1001	2.75	1.49	0.54	1047	2.68	1.45	0.54	1069	2.60	1.40	0.54	1092
30	26	3.09	1.30	0.42	1037	2.91	1.22	0.42	1083	2.82	1.18	0.42	1106	2.73	1.15	0.42	1128
31	18	2.50	2.35	0.94	892	2.30	2.16	0.94	946	2.21	2.07	0.94	965	2.12	1.99	0.94	983
31	20	2.63	2.15	0.82	928	2.45	2.01	0.82	974	2.36	1.93	0.82	1001	2.27	1.86	0.82	1028
31	22	2.78	1.95	0.70	965	2.60	1.82	0.70	1019	2.51	1.76	0.70	1037	2.42	1.70	0.70	1056
31	24	2.93	1.70	0.58	1001	2.75	1.60	0.58	1047	2.68	1.55	0.58	1069	2.60	1.51	0.58	1092
31	26	3.09	1.42	0.46	1037	2.91	1.34	0.46	1083	2.82	1.30	0.46	1106	2.73	1.26	0.46	1128
32	18	2.50	2.45	0.98	892	2.30	2.25	0.98	946	2.21	2.16	0.98	965	2.12	2.07	0.98	983
32	20	2.63	2.26	0.86	928	2.45	2.11	0.86	974	2.36	2.03	0.86	1001	2.27	1.95	0.86	1028
32	22	2.78	2.06	0.74	965	2.60	1.92	0.74	1019	2.51	1.86	0.74	1037	2.42	1.79	0.74	1056
32	24	2.93	1.82	0.62	1001	2.75	1.71	0.62	1047	2.68	1.66	0.62	1069	2.60	1.61	0.62	1092
32	26	3.09	1.54	0.50	1037	2.91	1.45	0.50	1083	2.82	1.41	0.50	1106	2.73	1.36	0.50	1128

NOTE Q : Total capacity (kW) SHF : Sensible heat factor DB : Dry-bulb temperature
 SHC : Sensible heat capacity (kW) INPUT : Total power input (W) WB : Wet-bulb temperature

PERFORMANCE DATA COOL operation
MSC-C12TV -E1 : MUH-C12TV -E1

CAPACITY: 3.45(KW) SHF: 0.70 INPUT: 1280(W)

		OUTDOOR DB(°C)															
INDOOR DB(°C)	INDOOR WB(°C)	21				25				27				30			
		Q	SHC	SHF	INPUT	Q	SHC	SHF	INPUT	Q	SHC	SHF	INPUT	Q	SHC	SHF	INPUT
21	18	4.05	2.11	0.52	1024	3.88	2.02	0.52	1075	3.73	1.94	0.52	1126	3.59	1.87	0.52	1178
21	20	4.23	1.69	0.40	1075	4.05	1.62	0.40	1139	3.93	1.57	0.40	1165	3.80	1.52	0.40	1216
22	18	4.05	2.27	0.56	1024	3.88	2.17	0.56	1075	3.73	2.09	0.56	1126	3.59	2.01	0.56	1178
22	20	4.23	1.86	0.44	1075	4.05	1.78	0.44	1139	3.93	1.73	0.44	1165	3.80	1.67	0.44	1216
22	22	4.40	1.41	0.32	1114	4.24	1.36	0.32	1184	4.14	1.32	0.32	1216	3.97	1.27	0.32	1267
23	18	4.05	2.43	0.60	1024	3.88	2.33	0.60	1075	3.73	2.24	0.60	1126	3.59	2.15	0.60	1178
23	20	4.23	2.03	0.48	1075	4.05	1.95	0.48	1139	3.93	1.89	0.48	1165	3.80	1.82	0.48	1216
23	22	4.40	1.58	0.36	1114	4.24	1.53	0.36	1184	4.14	1.49	0.36	1216	3.97	1.43	0.36	1267
24	18	4.05	2.59	0.64	1024	3.88	2.48	0.64	1075	3.73	2.38	0.64	1126	3.59	2.30	0.64	1178
24	20	4.23	2.20	0.52	1075	4.05	2.11	0.52	1139	3.93	2.05	0.52	1165	3.80	1.97	0.52	1216
24	22	4.40	1.76	0.40	1114	4.24	1.70	0.40	1184	4.14	1.66	0.40	1216	3.97	1.59	0.40	1267
24	24	4.62	1.29	0.28	1165	4.45	1.25	0.28	1229	4.35	1.22	0.28	1267	4.21	1.18	0.28	1331
25	18	4.05	2.76	0.68	1024	3.88	2.64	0.68	1075	3.73	2.53	0.68	1126	3.59	2.44	0.68	1178
25	20	4.23	2.37	0.56	1075	4.05	2.27	0.56	1139	3.93	2.20	0.56	1165	3.80	2.13	0.56	1216
25	22	4.40	1.94	0.44	1114	4.24	1.87	0.44	1184	4.14	1.82	0.44	1216	3.97	1.75	0.44	1267
25	24	4.62	1.48	0.32	1165	4.45	1.42	0.32	1229	4.35	1.39	0.32	1267	4.21	1.35	0.32	1331
26	18	4.05	2.92	0.72	1024	3.88	2.79	0.72	1075	3.73	2.68	0.72	1126	3.59	2.58	0.72	1178
26	20	4.23	2.54	0.60	1075	4.05	2.43	0.60	1139	3.93	2.36	0.60	1165	3.80	2.28	0.60	1216
26	22	4.40	2.11	0.48	1114	4.24	2.04	0.48	1184	4.14	1.99	0.48	1216	3.97	1.90	0.48	1267
26	24	4.62	1.66	0.36	1165	4.45	1.60	0.36	1229	4.35	1.56	0.36	1267	4.21	1.52	0.36	1331
26	26	4.76	1.14	0.24	1229	4.62	1.11	0.24	1293	4.55	1.09	0.24	1331	4.42	1.06	0.24	1370
27	18	4.05	3.08	0.76	1024	3.88	2.95	0.76	1075	3.73	2.83	0.76	1126	3.59	2.73	0.76	1178
27	20	4.23	2.70	0.64	1075	4.05	2.59	0.64	1139	3.93	2.52	0.64	1165	3.80	2.43	0.64	1216
27	22	4.40	2.29	0.52	1114	4.24	2.21	0.52	1184	4.14	2.15	0.52	1216	3.97	2.06	0.52	1267
27	24	4.62	1.85	0.40	1165	4.45	1.78	0.40	1229	4.35	1.74	0.40	1267	4.21	1.68	0.40	1331
27	26	4.76	1.33	0.28	1229	4.62	1.29	0.28	1293	4.55	1.28	0.28	1331	4.42	1.24	0.28	1370
28	18	4.05	3.24	0.80	1024	3.88	3.11	0.80	1075	3.73	2.98	0.80	1126	3.59	2.87	0.80	1178
28	20	4.23	2.87	0.68	1075	4.05	2.76	0.68	1139	3.93	2.67	0.68	1165	3.80	2.58	0.68	1216
28	22	4.40	2.46	0.56	1114	4.24	2.38	0.56	1184	4.14	2.32	0.56	1216	3.97	2.22	0.56	1267
28	24	4.62	2.03	0.44	1165	4.45	1.96	0.44	1229	4.35	1.91	0.44	1267	4.21	1.85	0.44	1331
28	26	4.76	1.52	0.32	1229	4.62	1.48	0.32	1293	4.55	1.46	0.32	1331	4.42	1.41	0.32	1370
29	18	4.05	3.41	0.84	1024	3.88	3.26	0.84	1075	3.73	3.13	0.84	1126	3.59	3.01	0.84	1178
29	20	4.23	3.04	0.72	1075	4.05	2.92	0.72	1139	3.93	2.83	0.72	1165	3.80	2.73	0.72	1216
29	22	4.40	2.64	0.60	1114	4.24	2.55	0.60	1184	4.14	2.48	0.60	1216	3.97	2.38	0.60	1267
29	24	4.62	2.22	0.48	1165	4.45	2.14	0.48	1229	4.35	2.09	0.48	1267	4.21	2.02	0.48	1331
29	26	4.76	1.71	0.36	1229	4.62	1.66	0.36	1293	4.55	1.64	0.36	1331	4.42	1.59	0.36	1370
30	18	4.05	3.57	0.88	1024	3.88	3.42	0.88	1075	3.73	3.28	0.88	1126	3.59	3.16	0.88	1178
30	20	4.23	3.21	0.76	1075	4.05	3.08	0.76	1139	3.93	2.99	0.76	1165	3.80	2.88	0.76	1216
30	22	4.40	2.82	0.64	1114	4.24	2.72	0.64	1184	4.14	2.65	0.64	1216	3.97	2.54	0.64	1267
30	24	4.62	2.40	0.52	1165	4.45	2.31	0.52	1229	4.35	2.26	0.52	1267	4.21	2.19	0.52	1331
30	26	4.76	1.90	0.40	1229	4.62	1.85	0.40	1293	4.55	1.82	0.40	1331	4.42	1.77	0.40	1370
31	18	4.05	3.73	0.92	1024	3.88	3.57	0.92	1075	3.73	3.43	0.92	1126	3.59	3.30	0.92	1178
31	20	4.23	3.38	0.80	1075	4.05	3.24	0.80	1139	3.93	3.15	0.80	1165	3.80	3.04	0.80	1216
31	22	4.40	2.99	0.68	1114	4.24	2.89	0.68	1184	4.14	2.82	0.68	1216	3.97	2.70	0.68	1267
31	24	4.62	2.59	0.56	1165	4.45	2.49	0.56	1229	4.35	2.43	0.56	1267	4.21	2.36	0.56	1331
31	26	4.76	2.09	0.44	1229	4.62	2.03	0.44	1293	4.55	2.00	0.44	1331	4.42	1.94	0.44	1370
32	18	4.05	3.89	0.96	1024	3.88	3.73	0.96	1075	3.73	3.58	0.96	1126	3.59	3.44	0.96	1178
32	20	4.23	3.55	0.84	1075	4.05	3.41	0.84	1139	3.93	3.30	0.84	1165	3.80	3.19	0.84	1216
32	22	4.40	3.17	0.72	1114	4.24	3.06	0.72	1184	4.14	2.98	0.72	1216	3.97	2.86	0.72	1267
32	24	4.62	2.77	0.60	1165	4.45	2.67	0.60	1229	4.35	2.61	0.60	1267	4.21	2.53	0.60	1331
32	26	4.76	2.29	0.48	1229	4.62	2.22	0.48	1293	4.55	2.19	0.48	1331	4.42	2.12	0.48	1370

NOTE Q : Total capacity (kW) SHF : Sensible heat factor DB : Dry-bulb temperature
 SHC : Sensible heat capacity (kW) INPUT : Total power input (W) WB : Wet-bulb temperature

PERFORMANCE DATA COOL operation

MSC-C12TV -[E1] : MUH-C12TV -[E1]

CAPACITY: 3.45(KW) SHF: 0.70 INPUT: 1280(W)

INDOOR DB(°C)	INDOOR WB(°C)	OUTDOOR DB(°C)															
		35				40				43				46			
		Q	SHC	SHF	INPUT	Q	SHC	SHF	INPUT	Q	SHC	SHF	INPUT	Q	SHC	SHF	INPUT
21	18	3.38	1.76	0.52	1254	3.11	1.61	0.52	1331	2.98	1.55	0.52	1357	2.86	1.49	0.52	1382
21	20	3.55	1.42	0.40	1306	3.31	1.32	0.40	1370	3.19	1.28	0.40	1408	3.07	1.23	0.40	1446
22	18	3.38	1.89	0.56	1254	3.11	1.74	0.56	1331	2.98	1.67	0.56	1357	2.86	1.60	0.56	1382
22	20	3.55	1.56	0.44	1306	3.31	1.46	0.44	1370	3.19	1.40	0.44	1408	3.07	1.35	0.44	1446
22	22	3.76	1.20	0.32	1357	3.52	1.13	0.32	1434	3.40	1.09	0.32	1459	3.28	1.05	0.32	1485
23	18	3.38	2.03	0.60	1254	3.11	1.86	0.60	1331	2.98	1.79	0.60	1357	2.86	1.72	0.60	1382
23	20	3.55	1.71	0.48	1306	3.31	1.59	0.48	1370	3.19	1.53	0.48	1408	3.07	1.47	0.48	1446
23	22	3.76	1.35	0.36	1357	3.52	1.27	0.36	1434	3.40	1.22	0.36	1459	3.28	1.18	0.36	1485
24	18	3.38	2.16	0.64	1254	3.11	1.99	0.64	1331	2.98	1.91	0.64	1357	2.86	1.83	0.64	1382
24	20	3.55	1.85	0.52	1306	3.31	1.72	0.52	1370	3.19	1.66	0.52	1408	3.07	1.60	0.52	1446
24	22	3.76	1.50	0.40	1357	3.52	1.41	0.40	1434	3.40	1.36	0.40	1459	3.28	1.31	0.40	1485
24	24	3.97	1.11	0.28	1408	3.73	1.04	0.28	1472	3.62	1.01	0.28	1504	3.52	0.99	0.28	1536
25	18	3.38	2.30	0.68	1254	3.11	2.11	0.68	1331	2.98	2.03	0.68	1357	2.86	1.95	0.68	1382
25	20	3.55	1.99	0.56	1306	3.31	1.85	0.56	1370	3.19	1.79	0.56	1408	3.07	1.72	0.56	1446
25	22	3.76	1.65	0.44	1357	3.52	1.55	0.44	1434	3.40	1.50	0.44	1459	3.28	1.44	0.44	1485
25	24	3.97	1.27	0.32	1408	3.73	1.19	0.32	1472	3.62	1.16	0.32	1504	3.52	1.13	0.32	1536
26	18	3.38	2.43	0.72	1254	3.11	2.24	0.72	1331	2.98	2.15	0.72	1357	2.86	2.06	0.72	1382
26	20	3.55	2.13	0.60	1306	3.31	1.99	0.60	1370	3.19	1.91	0.60	1408	3.07	1.84	0.60	1446
26	22	3.76	1.81	0.48	1357	3.52	1.69	0.48	1434	3.40	1.63	0.48	1459	3.28	1.57	0.48	1485
26	24	3.97	1.43	0.36	1408	3.73	1.34	0.36	1472	3.62	1.30	0.36	1504	3.52	1.27	0.36	1536
26	26	4.17	1.00	0.24	1459	3.93	0.94	0.24	1523	3.81	0.91	0.24	1555	3.69	0.89	0.24	1587
27	18	3.38	2.57	0.76	1254	3.11	2.36	0.76	1331	2.98	2.27	0.76	1357	2.86	2.18	0.76	1382
27	20	3.55	2.27	0.64	1306	3.31	2.12	0.64	1370	3.19	2.04	0.64	1408	3.07	1.97	0.64	1446
27	22	3.76	1.96	0.52	1357	3.52	1.83	0.52	1434	3.40	1.77	0.52	1459	3.28	1.70	0.52	1485
27	24	3.97	1.59	0.40	1408	3.73	1.49	0.40	1472	3.62	1.45	0.40	1504	3.52	1.41	0.40	1536
27	26	4.17	1.17	0.28	1459	3.93	1.10	0.28	1523	3.81	1.07	0.28	1555	3.69	1.03	0.28	1587
28	18	3.38	2.70	0.80	1254	3.11	2.48	0.80	1331	2.98	2.39	0.80	1357	2.86	2.29	0.80	1382
28	20	3.55	2.42	0.68	1306	3.31	2.25	0.68	1370	3.19	2.17	0.68	1408	3.07	2.09	0.68	1446
28	22	3.76	2.11	0.56	1357	3.52	1.97	0.56	1434	3.40	1.90	0.56	1459	3.28	1.84	0.56	1485
28	24	3.97	1.75	0.44	1408	3.73	1.64	0.44	1472	3.62	1.59	0.44	1504	3.52	1.55	0.44	1536
28	26	4.17	1.34	0.32	1459	3.93	1.26	0.32	1523	3.81	1.22	0.32	1555	3.69	1.18	0.32	1587
29	18	3.38	2.84	0.84	1254	3.11	2.61	0.84	1331	2.98	2.51	0.84	1357	2.86	2.41	0.84	1382
29	20	3.55	2.56	0.72	1306	3.31	2.38	0.72	1370	3.19	2.30	0.72	1408	3.07	2.21	0.72	1446
29	22	3.76	2.26	0.60	1357	3.52	2.11	0.60	1434	3.40	2.04	0.60	1459	3.28	1.97	0.60	1485
29	24	3.97	1.90	0.48	1408	3.73	1.79	0.48	1472	3.62	1.74	0.48	1504	3.52	1.69	0.48	1536
29	26	4.17	1.50	0.36	1459	3.93	1.42	0.36	1523	3.81	1.37	0.36	1555	3.69	1.33	0.36	1587
30	18	3.38	2.98	0.88	1254	3.11	2.73	0.88	1331	2.98	2.63	0.88	1357	2.86	2.52	0.88	1382
30	20	3.55	2.70	0.76	1306	3.31	2.52	0.76	1370	3.19	2.43	0.76	1408	3.07	2.33	0.76	1446
30	22	3.76	2.41	0.64	1357	3.52	2.25	0.64	1434	3.40	2.17	0.64	1459	3.28	2.10	0.64	1485
30	24	3.97	2.06	0.52	1408	3.73	1.94	0.52	1472	3.62	1.88	0.52	1504	3.52	1.83	0.52	1536
30	26	4.17	1.67	0.40	1459	3.93	1.57	0.40	1523	3.81	1.52	0.40	1555	3.69	1.48	0.40	1587
31	18	3.38	3.11	0.92	1254	3.11	2.86	0.92	1331	2.98	2.75	0.92	1357	2.86	2.63	0.92	1382
31	20	3.55	2.84	0.80	1306	3.31	2.65	0.80	1370	3.19	2.55	0.80	1408	3.07	2.46	0.80	1446
31	22	3.76	2.56	0.68	1357	3.52	2.39	0.68	1434	3.40	2.31	0.68	1459	3.28	2.23	0.68	1485
31	24	3.97	2.22	0.56	1408	3.73	2.09	0.56	1472	3.62	2.03	0.56	1504	3.52	1.97	0.56	1536
31	26	4.17	1.84	0.44	1459	3.93	1.73	0.44	1523	3.81	1.68	0.44	1555	3.69	1.62	0.44	1587
32	18	3.38	3.25	0.96	1254	3.11	2.98	0.96	1331	2.98	2.86	0.96	1357	2.86	2.75	0.96	1382
32	20	3.55	2.98	0.84	1306	3.31	2.78	0.84	1370	3.19	2.68	0.84	1408	3.07	2.58	0.84	1446
32	22	3.76	2.71	0.72	1357	3.52	2.53	0.72	1434	3.40	2.45	0.72	1459	3.28	2.36	0.72	1485
32	24	3.97	2.38	0.60	1408	3.73	2.24	0.60	1472	3.62	2.17	0.60	1504	3.52	2.11	0.60	1536
32	26	4.17	2.00	0.48	1459	3.93	1.89	0.48	1523	3.81	1.83	0.48	1555	3.69	1.77	0.48	1587

NOTE Q : Total capacity (kW) SHF : Sensible heat factor DB : Dry-bulb temperature
 SHC : Sensible heat capacity (kW) INPUT : Total power input (W) WB : Wet-bulb temperature

PERFORMANCE DATA HEAT operation
MSC-C07TV -[E1] : MUH-C07TV -[E1]

CAPACITY : 2.5(KW) INPUT : 710(W)

INDOOR DB(°C)	OUTDOOR WB(°C)													
	-10		-5		0		5		10		15		20	
	Q	INPUT	Q	INPUT	Q	INPUT	Q	INPUT	Q	INPUT	Q	INPUT	Q	INPUT
15	1.58	462	1.90	554	2.23	625	2.55	675	2.88	717	3.18	738	3.50	753
21	1.50	497	1.80	589	2.13	653	2.43	703	2.75	738	3.05	760	3.36	788
26	1.35	533	1.68	625	1.98	689	2.30	738	2.63	774	2.93	795	3.25	817

NOTE : Q:Total capacity (kW) INPUT:Total power input (W) DB : Dry-bulb temperature WB : Wet-bulb temperature

MSC-C09TV -[E1] : MUH-C09TV -[E1]

CAPACITY : 3.2(KW) INPUT : 960(W)

INDOOR DB(°C)	OUTDOOR WB(°C)													
	-10		-5		0		5		10		15		20	
	Q	INPUT	Q	INPUT	Q	INPUT	Q	INPUT	Q	INPUT	Q	INPUT	Q	INPUT
15	2.02	624	2.43	749	2.85	845	3.26	912	3.68	970	4.06	998	4.48	1018
21	1.92	672	2.30	797	2.72	883	3.10	950	3.52	998	3.90	1027	4.30	1066
26	1.73	720	2.14	845	2.53	931	2.94	998	3.36	1046	3.74	1075	4.16	1104

NOTE : Q:Total capacity (kW) INPUT:Total power input (W) DB : Dry-bulb temperature WB : Wet-bulb temperature

MSC-C12TV -[E1] : MUH-C12TV -[E1]

CAPACITY : 4.2(KW) INPUT : 1370(W)

INDOOR DB(°C)	OUTDOOR WB(°C)													
	-10		-5		0		5		10		15		20	
	Q	INPUT	Q	INPUT	Q	INPUT	Q	INPUT	Q	INPUT	Q	INPUT	Q	INPUT
15	2.65	891	3.19	1069	3.74	1206	4.28	1302	4.83	1384	5.33	1425	5.88	1452
21	2.52	959	3.02	1137	3.57	1260	4.07	1356	4.62	1425	5.12	1466	5.65	1521
26	2.27	1028	2.81	1206	3.32	1329	3.86	1425	4.41	1493	4.91	1534	5.46	1576

NOTE : Q:Total capacity (kW) INPUT:Total power input (W) DB : Dry-bulb temperature WB : Wet-bulb temperature

9

MICROPROCESSOR CONTROL

MSC-C07TV -[E1] MU-C07TV -[E1] MUH-C07TV -[E1]
 MSC-C09TV -[E1] MU-C09TV -[E1] MUH-C09TV -[E1]
 MSC-C12TV -[E1] MU-C12TV -[E1] MUH-C12TV -[E1]

Once the operation mode are set, the same operation mode can be repeated by simply turning the OPERATE/STOP (ON/OFF) button ON. Indoor unit receives the signal with a beep tone.

When the system turns off, 3-minute time delay will operate to protect system from overload and compressor will not restart for 3 minutes.

WIRELESS REMOTE CONTROLLER

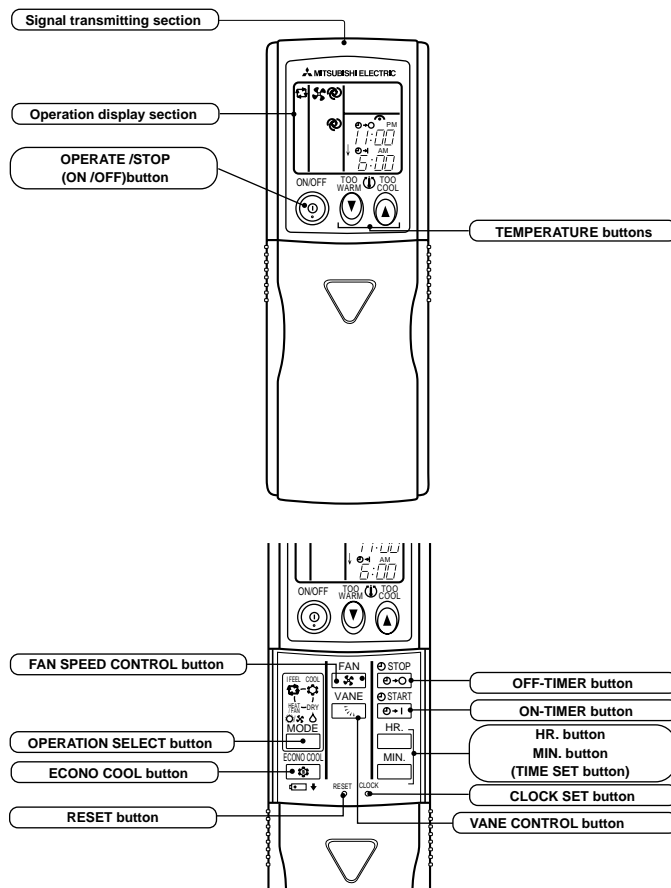

INDOOR UNIT DISPLAY SECTION

Operation indicator lamp

The operation indicator at the right side of the indoor unit indicates the operation state.

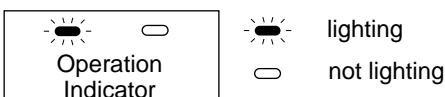

Indication	Operation state	Difference between target temperature and room temperature
	This shows that the air conditioner is operating to reach the target temperature. Please wait until the target temperature is obtained.	Approx. 2 °C or more
	This shows that the room temperature is approaching the target temperature.	Approx. 2 °C or less

9-1. COOL () OPERATION

- (1) Press OPERATE/STOP(ON/OFF) button. OPERATION INDICATOR lamp of the indoor unit turns on with a beep tone.
- (2) Select COOL mode with the OPERATION SELECT button.
- (3) Press TEMPERATURE buttons (TOO WARM or TOO COOL button) to select the desired temperature.
The setting range is 16 ~ 31°C

1. Indoor fan speed control

Indoor fan operates continuously at the set speed by FAN SPEED CONTROL button regardless of thermostat's OFF-ON.

In Auto the fan speed is as follows.

Initial temperature difference	Fan speed	Difference between room temperature and set temperature during operation
Room temperature minus set temperature : 2 degrees or more	High	3 deg.
Room temperature minus set temperature : Between 1 and 2 degrees	Med.	1.7 deg.
Room temperature minus set temperature : less than 1 degree	Low	1 deg.

2. Coil frost prevention

① Temperature control

When the indoor coil thermistor RT12 reads 4°C or below(MSC-C07/C09TV) / 0°C or below(MSC-C12TV) for 5 minutes, the coil frost prevention mode starts.

The indoor fan operates at the set speed and the compressor stops for 5 minutes.

After that, if RT12 still reads below 4°C (MSC-C07/C09TV) / 0°C (MSC-C12TV), this mode is prolonged until the RT12 reads over 4°C (MSC-C07/C09TV) / 0°C (MSC-C12TV).

② Time control

When the three conditions as follows have been satisfied for 1 hour and 45 minutes, the compressor stops for 3 minutes. The indoor fan operates at the set speed.

- a. Compressor has been continuously operating.
- b. Indoor fan speed is Low or Med..
- c. Room temperature is below 26°C.

When compressor stops, the accumulated time is cancelled. When compressor restarts, time counting starts from the beginning.

Time counting also stops temporarily when the indoor fan speed becomes High or the room temperature exceeds 26°C. However, when two of the above conditions (b.and c.) are satisfied again, time accumulation is resumed.

Operation chart

Example

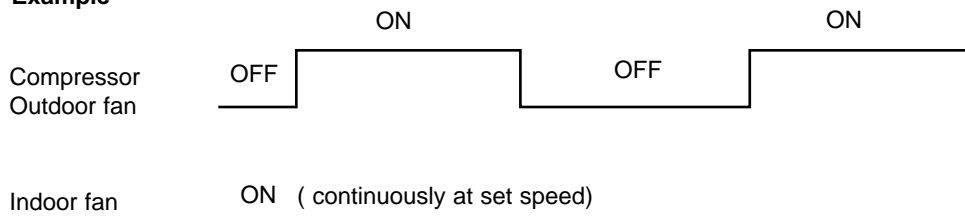

9-2. DRY (△) OPERATION

- (1) Press OPERATE/STOP(ON/OFF) button.
OPERATION INDICATOR lamp of the indoor unit turns on with a beep tone.
- (2) Select DRY mode with the OPERATION SELECT button.
- (3) The microprocessor reads the room temperature and determines the set temperature. Set temperature is as shown on the right chart.
DRY operation will not function when the room temperature is 13°C or below.

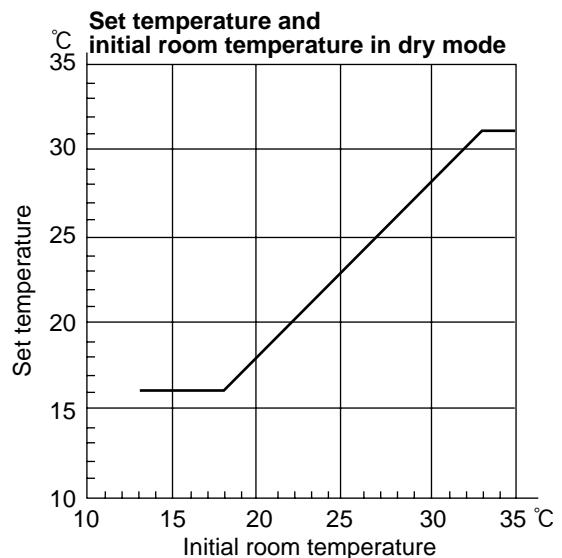

The system for dry operation uses the same refrigerant circuit as the cooling circuit.

The compressor and the indoor fan are controlled by the room temperature.

By such controls, indoor flow amounts will be reduced in order to lower humidity without much room temperature decrease.

1. Indoor fan speed control

Indoor fan operates at the set speed by FAN SPEED CONTROL button .

In Auto fan speed becomes Low.

2. The operation of the compressor and indoor / outdoor fan

Compressor operates by room temperature control and time control.

Indoor fan and outdoor fan operate in the same cycle as the compressor.

● When the room temperature is 23°C or over:

When the thermostat is ON, the compressor repeats 8 minutes ON and 3 minutes OFF.

When the thermostat is OFF, the compressor repeats 4 minutes OFF and 1 minute ON.

● When the room temperature is under 23°C.

When the thermostat is ON, the compressor repeats 2 minutes ON and 3 minutes OFF.

When the thermostat is OFF, the compressor repeats 4 minutes OFF and 1 minute ON.

Operation time chart

Example

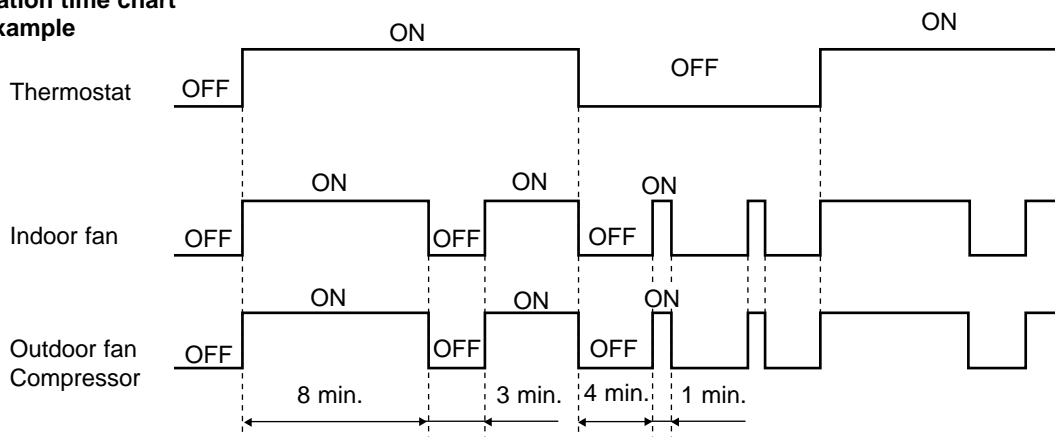

3. Coil frost prevention

The operation is as same as coil frost prevention during COOL operation.(Refer to 9-1.2. Coil frost prevention)

However when coil frost prevention works while the indoor fan is OFF, it's speed becomes set speed..

9-3. FAN (*) OPERATION <MU-C07/C09/C12TV>

(1) Press OPERATE/STOP(ON/OFF) button. OPERATION INDICATOR lamp of the indoor unit turns on with a beep tone.

(2) Select FAN mode with the OPERATION SELECT button.

(3) Select the desired fan speed. When AUTO, it becomes Low.

Only indoor fan operates.

Outdoor unit does not operate.

9-4. HEAT (☉) OPERATION <MUH-C07/C09/C12TV>

(1) Press OPERATE/STOP(ON/OFF) button.

OPERATION INDICATOR lamp of the indoor unit turns on with a beep tone.

(2) Select HEAT mode with the OPERATION SELECT button.

(3) Press TEMPERATURE buttons (TOO WARM or TOO COOL button) to select the desired temperature.

The setting range is 16 ~ 31°C.

1. Indoor fan speed control

(1) Indoor fan operates at the set speed by FAN SPEED CONTROL button.

In Auto the fan speed is as follows.

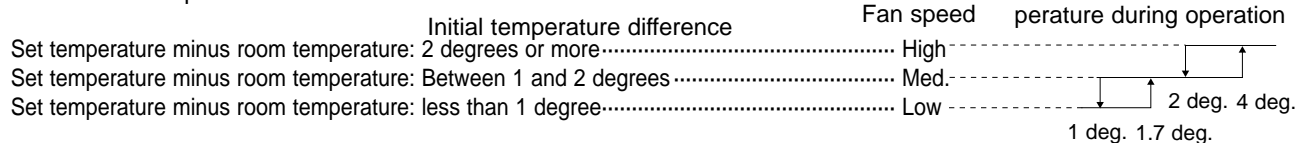

(2) Cold air prevention control

- ① When the compressor is not operating,
 - (I) if the temperature of indoor coil thermistor RT12 is 18°C or less, the fan stops.
 - (II) if the temperature of indoor coil thermistor RT12 is more than 18°C, the fan operates at Very Low.
- ② When the compressor is operating,
 - (I) if the temperature of RT12 is 22°C or more, the fan operates at set speed.
 - (II) if the temperature of RT12 is less than 22°C and
 - (i) if the temperature of room temperature thermistor RT11 is 15°C or less, the fan stops.
 - (ii) if the temperature of room temperature thermistor RT11 is more than 15°C, the fan operates at Very Low.

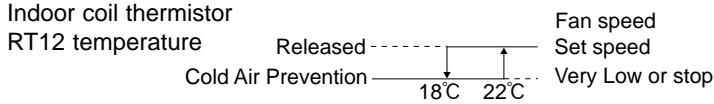

NOTE : If the temperature of RT12 reads from 18°C to 22°C at the air conditioner starting and also after defrosting, this control works.

(3) Warm air control.

When the following any condition of ①(a. ~ d.) and the condition of ② are satisfied at the same time, warm air control works.

- ① a.) when the operation mode has been changed to HEAT mode
- b.) when cold air prevention has been released
- c.) when defrosting has been finished
- d.) when the compressor starts in HEAT mode
- ② When the temperature of indoor coil thermistor RT12 is less than 37°C.

When warm air control works, the fan speed changes as follows to blow out warm air gradually.

Gradation of fan speed in initial

<Time condition>	<Indoor fan speed>
less than 2 minutes	Low
2 minutes to 4 minutes	Med.
more than 4 minutes	High

The upper limit of the fan speed in MANUAL is the set speed.

The upper limit of the fan speed in AUTO is the speed decided by indoor fan speed control.

(Refer to 9-4.1. Indoor fan speed control (1).)

When the temperature of RT12 has been 37°C or more, or when the set speed has been changed, this control is released and the fan speed is the set speed.

(4) Flow soft control

When the thermostat (compressor) is off, the indoor fan operates as follows.

RT12	fan
less than 18°C	off
18°C or more	Very Low

NOTE : When the thermostat (compressor) turns on, the fan will operate at set speed. But until cold air prevention and warm air control is released, the fan speed follow them.

2. High pressure protection

During heating operation, the outdoor fan motor is controlled by the temperature of indoor coil thermistor RT12 for excess rise protection of compressor discharge pressure.

Outdoor fan OFF: 52°C (MUH-C07/C09TV)
56°C (MUH-C12TV)

Outdoor fan ON: 48°C (MUH-C07/C09TV)
52°C (MUH-C12TV)

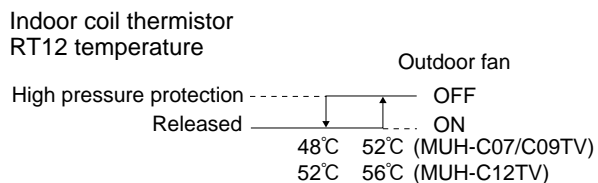

Operation chart

Example

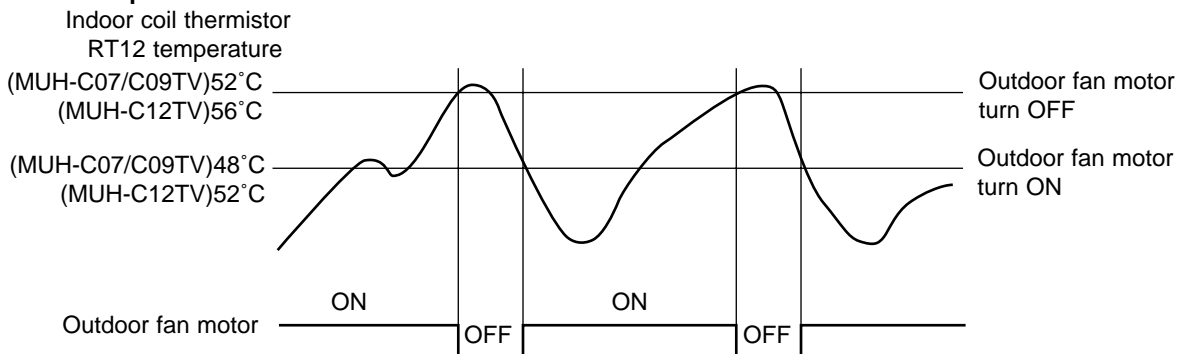

NOTE : During high pressure protection and for 4 min. and 15 sec. after high pressure protection, defrosting of outdoor heat exchanger is not detected by the defrost thermistor RT61. (Refer to 9-4.3. Defrosting)

3. Defrosting

Defrosting of outdoor heat exchanger is controlled by DEICER P.C. board, with detection by the defrost thermistor RT61.

(1) Starting conditions of defrost

When all conditions of a) ~ c) are satisfied, the defrosting operation starts.

a) The compressor cumulative operation time exceeds 40 minutes without the defrosting operation working.

b) RT61 reads - 4.6°C(MUH-C07TV)/ - 2.7°C(MUH-C09/C12TV) or less.

c) After releasing the high pressure protection 4 minutes and 15 seconds have elapsed.

(2) Releasing conditions of defrost

When the condition d) or e) is satisfied, the defrosting operation stops.

d) RT61 reads 12.8°C(MUH-C07TV)/ 16.3°C(MUH-C09/C12TV) or more.

e) The defrosting time exceeds 10 minutes.

Operation time chart

Example

Defrost thermistor RT61

12.8°C(MUH-C07TV) or more

16.3°C(MUH-C09/C12TV) or more

- 4.6°C(MUH-C07TV) or less

- 2.7°C(MUH-C09/C12TV) or less

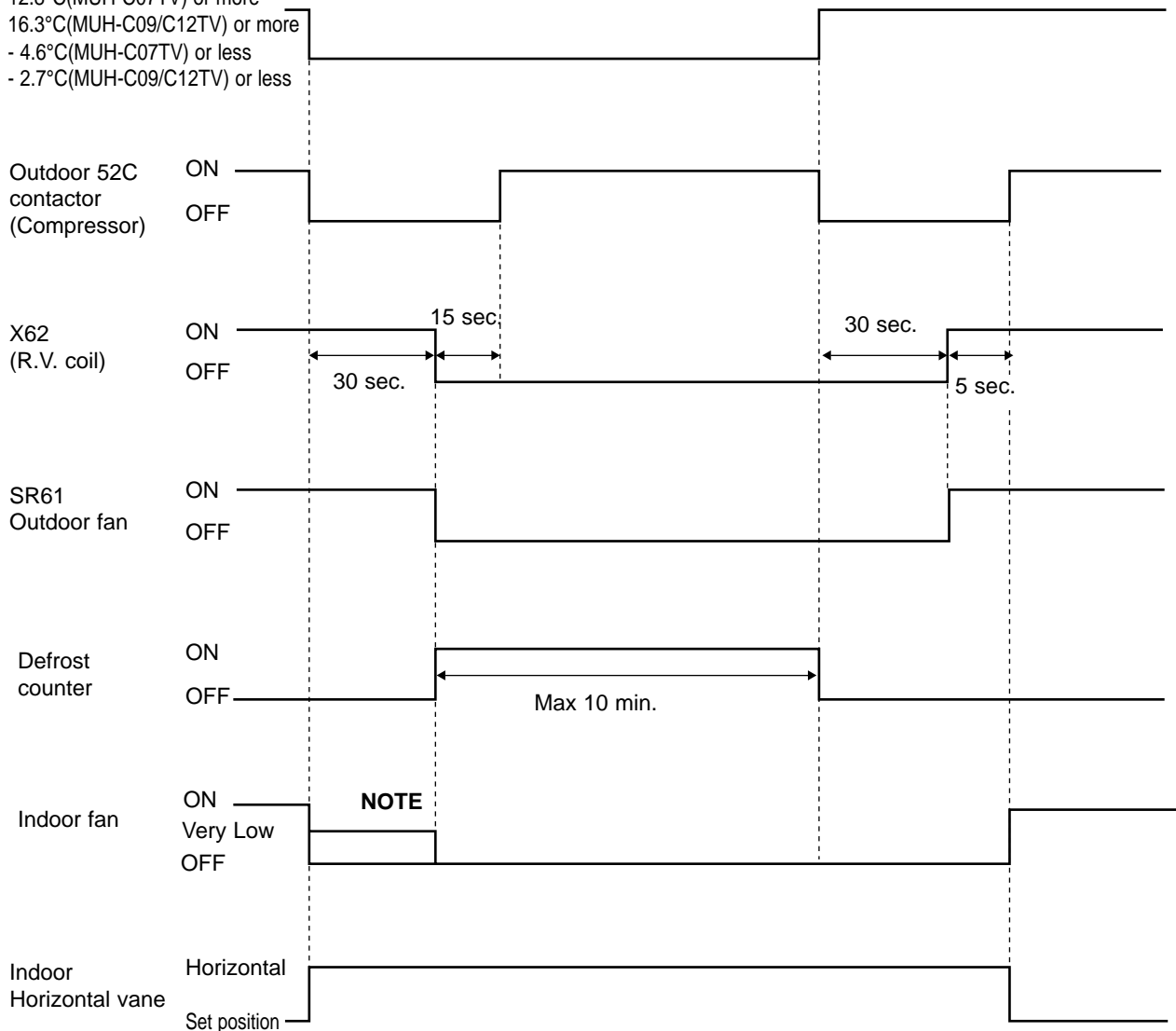

NOTE ● When the indoor coil thermistor RT12 reads above 18°C, indoor fan operates at Very Low for 30 seconds.

● When the indoor coil thermistor RT12 reads 18°C or less, the indoor fan stops.

4. R.V. coil control

- Heating ON
- Cooling OFF
- Dry OFF

NOTE : When operation starts, the 4-way valve reverses for 5 seconds right before start-up of the compressor.

Operation time chart

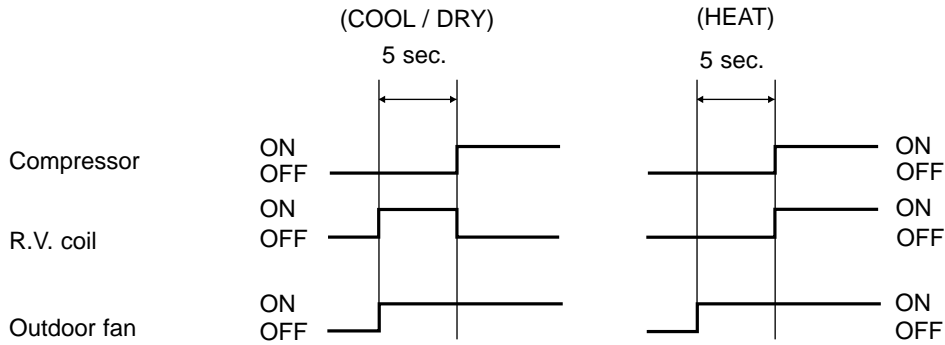

9-5. "I FEEL CONTROL" (□) OPERATION

- (1) Press OPERATE/STOP(ON/OFF) button on the remote controller. OPERATION INDICATOR lamp of the indoor unit turns on with a beep tone.
- (2) Select "I FEEL CONTROL"(□) mode with the OPERATION SELECT button.
- (3) The operation mode is determined by the initial room temperature at start-up of the operation, as shown on the right table.

Initial room temperature		Mode
MU type	MUH type	
25°C or more	25°C or more	COOL mode of "I FEEL CONTROL"
more than 13°C, less than 25°C	23°C or more, less than 25°C	DRY mode of "I FEEL CONTROL"
—	less than 23°C	HEAT mode of "I FEEL CONTROL"

- Once the mode is fixed, the mode does not change by room temperature afterwards.
- Under the ON-TIMER (⊕ → |) operation, mode is determined according to the room temperature at set time the operation starts.
- When the system is stopped on the remote controller and restarted within 2 hours in "I FEEL CONTROL" (□) mode, the system operates in previous mode automatically regardless of the room temperature.

Operation time chart

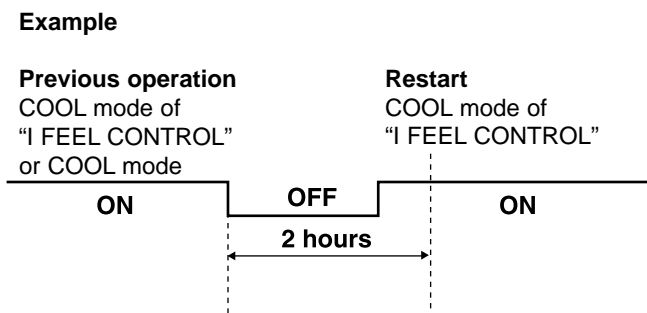

When the system is restarted after 2 hours and more, the operation mode is determined by the room temperature at start-up of the operation.

Operation time chart

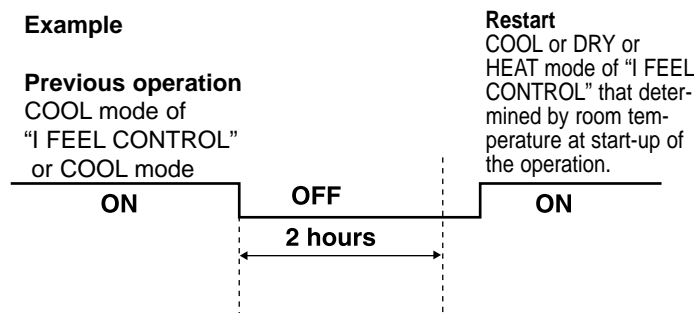

*Heat is available only in MUH-C07/C09/C12TV.

(4) The initial set temperature is decided by the initial room temperature.

Mode	Initial room temperature		Initial set temperature	
	MU type	MUH type		
COOL mode of "I FEEL CONTROL"	26°C or more	26°C or more	24°C	*1
	25°C to 26°C	25°C to 26°C	Initial room temperature minus 2°C	
DRY mode of "I FEEL CONTROL"	more than 13°C, less than 25°C	23°C to 25°C	Initial room temperature minus 2°C	
HEAT mode of "I FEEL CONTROL"	————	less than 23°C	26°C	

*1 When the system is restarted with the remote controller, the system operates with the previous set temperature regardless of the room temperature at restart.
The set temperature is calculated by the previous set temperature.

(5) TEMPERATURES buttons

In "I FEEL CONTROL" () mode, set temperature is decided by the microprocessor based on the room temperature. In addition, set temperature can be controlled by TOO WARM or TOO COOL buttons when you feel too cool or too warm. Each time the TOO WARM or TOO COOL button is pressed, the indoor unit receives the signal and emits a beep tone.

● Fuzzy control

When the TOO COOL or TOO WARM button is pressed, the microprocessor changes the set temperature, considering the room temperature, the frequency of pressing TOO COOL or TOO WARM button and the user's preference to heat or cool. So this is called "Fuzzy control", and works only in "I FEEL CONTROL" mode. In DRY mode of "I FEEL CONTROL", the set temperature doesn't change.



... To raise the set temperature 1~2 degrees(°C)



... To lower the set temperature 1~2 degrees(°C)

— COOL mode of "I FEEL CONTROL" —

1. Indoor fan speed control

Indoor fan speed control is as same as COOL OPERATION.(9-1.1. Indoor fan speed control)

2. Coil frost prevention

Coil frost prevention is as same as COOL OPERATION.(9-1.2. Coil frost prevention)

— DRY mode of "I FEEL CONTROL" —

1. Indoor fan speed control

Indoor fan speed control is as same as DRY OPERATION.(9-2.1. Indoor fan speed control)

2. The operation of the compressor and indoor / outdoor fan

The operation of the compressor and indoor / outdoor fan is as same as DRY OPERATION.
(9-2.2. The operation of the compressor and indoor / outdoor fan)

3. Coil frost prevention

Coil frost prevention is as same as DRY OPERATION.(9-2.3. Coil frost prevention)

— HEAT mode of "I FEEL CONTROL" — <MUH-C07/C09/C12TV>

1. Indoor fan speed control

Indoor fan speed control is as same as HEAT OPERATION.(9-4.1. Indoor fan speed control)

2. High pressure protection

High pressure protection is as same as HEAT OPERATION.(9-4.2. High pressure protection)

3. Defrosting

Defrosting is as same as HEAT OPERATION.(9-4.3. Defrosting)

4. R.V. coil control

R.V. coil control is as same as HEAT OPERATION.(9-4.4. R.V. coil control)

9-6. FAN MOTOR CONTROL

(1) Rotational frequency feedback control

The indoor fan motor is equipped with a rotational frequency sensor, and outputs signal to the microprocessor to feedback the rotational frequency. Comparing the current rotational frequency with the target rotational frequency (High, Med., Low), the microprocessor controls SR141 and adjusts fan motor electric current to make the current rotational frequency close to the target rotational frequency. With this control, when the fan speed is switched, the rotational frequency changes smoothly.

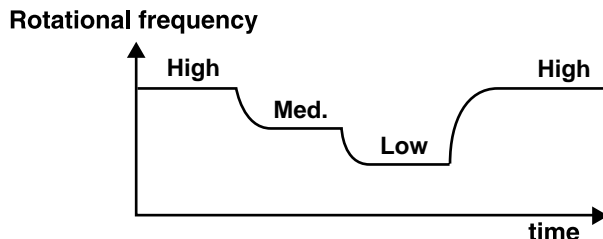

(2) Fan motor lock-up protection

When the rotational frequency feedback signal is not output for 12 seconds, (or when the microprocessor cannot detect the signal for 12 seconds) the fan motor is regarded locked-up. Then the electric current to the fan motor is shut off. 3 minutes later, the electric current is applied to the fan motor again. During the fan motor lock-up, the OPERATION INDICATOR lamp flashes on and off to show the fan motor abnormality. (Refer to page 50.)

9-7. AUTO VANE OPERATION

(1) Vane motor drive

These models are equipped with a stepping motor for the horizontal vane. The rotating direction, speed, and angle of the motor are controlled by pulse signals (approx. 12V) transmitted from indoor microprocessor.

(2) The horizontal vane angle and mode changes as follows by pressing the VANE CONTROL button.

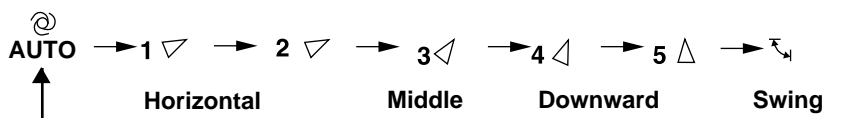

(3) Positioning

The vane is once pressed to the vane stopper below to confirm the standard position and then set to the desired angle. Confirming of standard position is performed in case of follows.

- When the OPERATE / STOP(ON / OFF) button is pressed (Power ON/OFF).
- When the vane control is changed from AUTO to MANUAL.
- When the SWING is finished.
- When the test run starts.
- When the power supply turns ON.

(4) VANE AUTO (Ⓐ) mode

In VANE AUTO mode, the microprocessor automatically determines the vane angle and operation to make the optimum room-temperature distribution.

- In COOL and DRY operation

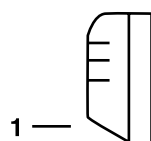

Vane angle is fixed to Angle 1.

- In FAN operation <MU-C07/C09/C12TV>

- In HEAT operation <MUH-C07/C09/C12TV>

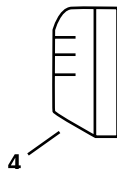

Vane angle is fixed to Angle 4.

(5) STOP (operation OFF) and ON-TIMER standby.

When the following cases occur, the vane returns to the closed position.

- When the OPERATE/STOP(ON/OFF) button is pressed (POWER OFF).
- When the operation is stopped by the emergency operation.
- When the ON-TIMER is on standby.

(6) Dew prevention

During COOL or DRY operation at Vane Angle 4 or 5 when the cumulative operation time of compressor exceeds 1 hour, the vane angle automatically changes to Angle 1 for dew prevention.

(7) SWING MODE (⌄)

By selecting SWING mode with the VANE CONTROL button, the horizontal vane swings vertically. The remote controller displays "⌄".

(8) Cold air prevention in HEAT operation<MUH-C07/C09/C12TV>

When any of the following conditions occurs in HEAT operation, the horizontal vane angle changes to Angle 1 automatically to prevent cold air blowing on users.

- ① Compressor is not operating.
- ② Defrosting is performed.
- ③ Indoor coil thermistor RT12 reads 24°C or below.
- ④ Indoor coil thermistor RT12 temperature is raising from 24°C or below, but it does not exceed 28°C.

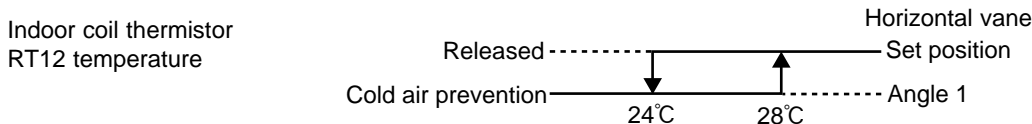

NOTE : If the temperature of RT12 reads from 24°C to 28°C at the air conditioner starting this control works.

(9) ECONO COOL () operation (ECONOMical operation)

When the ECONO COOL button is pressed in COOL mode, set temperature is automatically set 2°C higher than that in COOL mode.

Also the horizontal vane swings in various cycle according to the temperature of indoor heat exchanger(RT12). SWING operation makes you feel cooler than set temperature. So, even though the set temperature is higher than that in COOL mode, the air conditioner can keep comfort. As a result, energy can be saved.

ECONO COOL operation is cancelled when the ECONO COOL button is pressed once again or VANE CONTROL button is pressed or change to other operation mode.

NOTE : ECONO COOL operation not work in COOL mode of “I FEEL CONTROL”.

SWING operation

In swing operation of ECONO COOL operation air flow is initially blew out upward(levelly).

According to the temperature of indoor coil thermistor RT12 at starting of this operation, next downward blow time is decided. Then when the downward blow has been finished, next upward blow time is decided.

For initial 10 minutes the swing operation is performed in table G~H for quick cooling(but G : RT 12 is 24°C or less).

Also, after 10 minutes when the difference of set temperature and room temperature is more than 2°C, the swing operation is performed in table D~H for more cooling(but D: RT12 is 20°C or less).

The air conditioner repeats the swing operation in various cycle as follows.

	Temperature of indoor coil thermistor RT12	Downward blow time (sec.)	Upward(level) blow time (sec.)
A	15°C or less	2	23
B	15°C to 17°C	5	20
C	17°C to 18°C	8	17
D	18°C to 20°C	11	14
E	20°C to 21°C	14	11
F	21°C to 22°C	17	8
G	22°C to 24°C	20	5
H	more than 24°C	23	2

9-8. TIMER OPERATION

1. How to set the timer

(1) Press OPERATE/STOP(ON/OFF) button to start the air conditioner.

(2) Check that the current time is set correctly.

NOTE : Timer operation will not work without setting the current time. Initially “AM0:00” blinks at the current time display of TIME MONITOR, so set the current time correctly with CLOCK SET button.

(3) Press ON/OFF TIMER buttons to select the operation.

ON-TIMER button... AUTO START operation (ON timer)

OFF-TIMER button... AUTO STOP operation (OFF timer)

(4) Press HR. and MIN. button (TIME SET button) to set the timer. Time setting is 10-minute units.

HR. and MIN. button will work when “ ⊕→| ” or “ ⊕→○ ” mark is flashing.
 These marks disappear in 1 minute.

After setting the ON timer, check that OPERATION INDICATOR lamp of the indoor unit lights.

NOTE1 : Be sure to place the remote controller at the position where its signal can reach the air conditioner even during TIMER operation, or the set time may deviate within the range of about 10 minutes.

NOTE2 : Reset the timer in the following cases, or the set time may deviate and other malfunctions may occur.

- A power failure occurs.
- The circuit breaker functions.

2. Cancel

TIMER setting can be cancelled with the ON/OFF TIMER buttons.

To cancel the ON timer, press the ON-TIMER button.

To cancel the OFF timer, press the OFF-TIMER button.

TIMER is cancelled and the display of set time disappears.

PROGRAM TIMER

- The OFF timer and ON timer can be used in combination.
- “ ↑ ” and “ ↓ ” display shows the order of the OFF timer and ON timer operation.

(Example 1) The current time is 8:00 PM.
 The unit turns off at 11:00 PM, and on at 6:00 AM.

(Example 2) The current time is 11:00 AM.
 The unit turns on at 5:00 PM, and off at 9:00 PM.

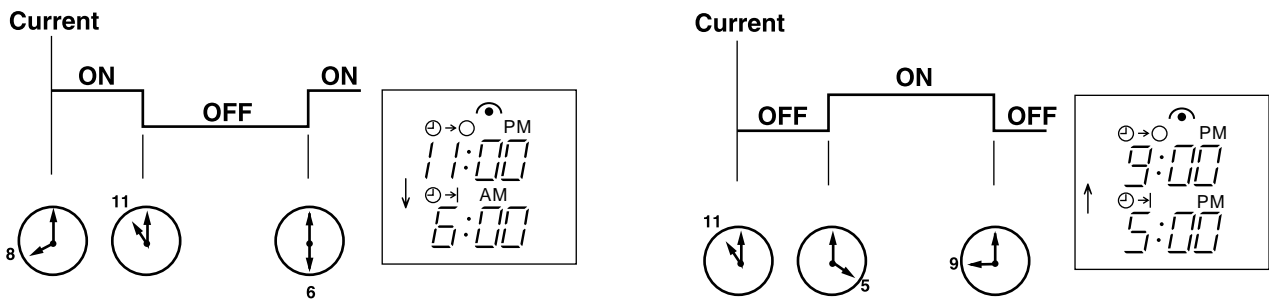

NOTE : TIMER setting will be cancelled by power failure or breaker functioning.

9-9. EMERGENCY-TEST OPERATION

In case of test run operation or emergency operation, use the EMERGENCY OPERATION switch on the front of the indoor unit. Emergency operation is available when the remote controller is missing, has failed or the batteries of remote controller run down. The unit will start and the OPERATION INDICATOR lamp will light.

The first 30 minutes of operation is the test run operation. This operation is for servicing. The indoor fan speed runs at High speed and the system is in continuous operation. (The thermostat is ON.)

After 30 minutes of test run operation the system shifts to EMERGENCY COOL / HEAT<MUH-C07/C09/C12TV only> MODE with a set temperature of 24°C.

The fan speed shifts to Med. speed.

The coil frost prevention works even in emergency operation, and defrosting <MUH-C07/C09/C12TV only> too.

In the test run or emergency operation, the horizontal vane operates in VANE AUTO (@) mode.

Emergency operation continues until the EMERGENCY OPERATION switch is pressed once again(MU-C07/C09/C12TV)/ once or twice(MUH-C07/C09/C12TV) or the unit receives any signal from the remote controller. In case of latter normal operation will start.

NOTE : Do not press the EMERGENCY OPERATION switch during normal operation.

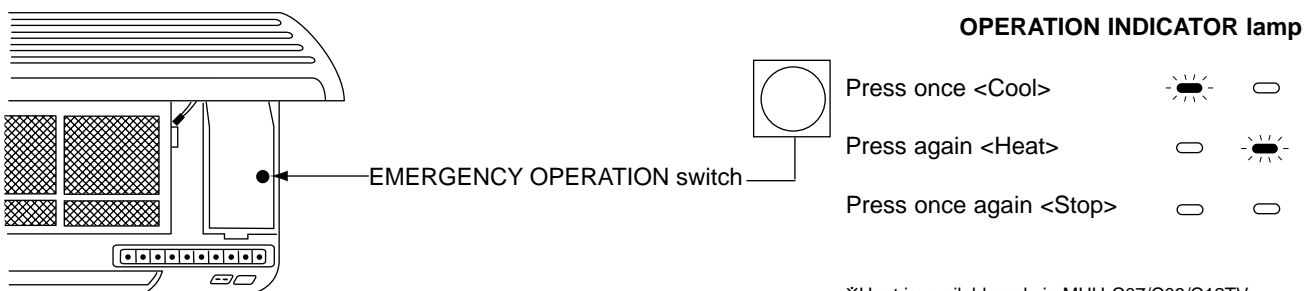

*Heat is available only in MUH-C07/C09/C12TV.

MSC-C07TV -E1 MU-C07TV -E1 MUH-C07TV -E1

MSC-C09TV -E1 MU-C09TV -E1 MUH-C09TV -E1

MSC-C12TV -E1 MU-C12TV -E1 MUH-C12TV -E1

10-1. COMPULSORY DEFROSTING MODE FOR SERVICE<MUH-C07/C09/C12TV>

By short circuit of the connector JP607 and R853 on the outdoor deicer P.C. board, defrosting mode can be accomplished regardless of the defrost interval restriction. (Refer to page 58.)
 Defrost thermistor RT61 must read below -4.6°C(MUH-C07TV)/ -2.7°C(MUH-C09/C12TV).

10-2. CHANGE IN DEFROST SETTING<MUH-C07/C09/C12TV>

<JPC> when the JPC wire of the deicer P.C. board is cut, the defrost interval time will be changed. (Refer to page 58.)

Model	Jumper wire	Change point
MUH-C07TV - E1	JPC	Defrost interval time changes from 40 minutes to 15 minutes.
MUH-C09TV - E1		
MUH-C12TV - E1		

10-3. TIMER SHORT MODE

For service, set time can be shortened by short circuit of JPG and JPS the electronic control P.C. board. The time will be shortened as follows.(Refer to page 57.)

Set time : 1 minute → 1-second

Set time : 3 minute → 3-second (It takes 3 minutes for the compressor to start operation. However, the starting time is shortened by short circuit of JPG and JPS.)

10-4. P.C. BOARD MODIFICATION FOR INDIVIDUAL OPERATION

A maximum of 4 indoor units with wireless remote controllers can be used in a room.

In this case, to operate each indoor unit individually by each remote controller, P.C. boards of remote controller must be modified according to the number of the indoor unit.

How to modify the remote controller P.C. board

Remove batteries before modification.

The board has a print as shown below :

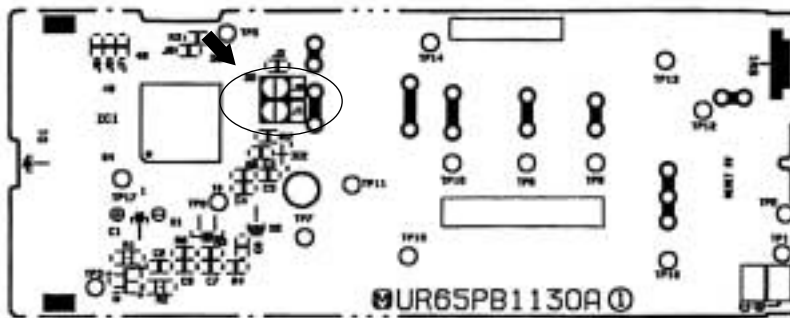

NOTE : For remodelling, take out the batteries and push the OPERATE/STOP(ON/OFF)button twice or 3 times at first. After finish remodelling, put back the batteries then push the RESET button.

The P.C. board has the print "J1" and "J2". Solder "J1" and "J2" according to the number of indoor unit as shown in Table 1. After modification, push the RESET button.

Table 1

	1 unit operation	2 units operation	3 units operation	4 units operation
No. 1 unit	No modification	Same as at left	Same as at left	Same as at left
No. 2 unit	–	Solder J1	Same as at left	Same as at left
No. 3 unit	–	–	Solder J2	Same as at left
No. 4 unit	–	–	–	Solder both J1 and J2

NOTE : At power supply failure or installation, indoor unit deletes the memory about remote controller. When the power supply is turned on and indoor unit receives the first signals from the remote controller, the remote controller number is designated as the indoor unit number. Therefore at and after the second time indoor unit accepts the remote controller of the initial setting number.

At setting - error, turn the power supply off to cancel the individual operation and then turn the power supply on to restart the setting.

10-5. REMOTE CONTROLLER (How to set the type)

This remote controller setting needs to be switched according to the type of air conditioner (COOL & HEAT or COOL ONLY).

If the setting is incorrect, the air conditioner does not operate normally. Therefore, check if the setting corresponds to the type of air conditioner. If it does not, correct the setting as shown below.

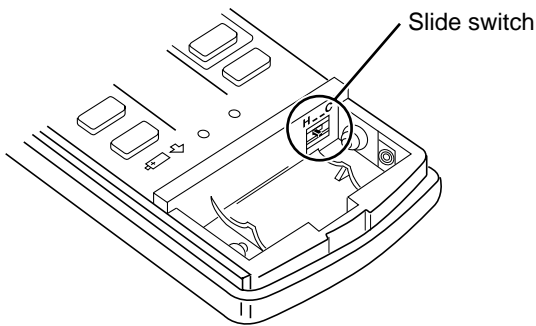

Type	COOL & HEAT	COOL ONLY
The position of the slide switch		

10-6. MU TYPE / MUH TYPE SWITCH OVER AND AUTO RESTART FUNCTION

1. MU TYPE / MUH TYPE SWITCH OVER

The indoor units for MU type and MUH type are common specifications. Set switch on the indoor electronic control P.C. board according to the type of outdoor unit. The units are set for MUH type when they are shipped from the factory.

How to switch over MU TYPE / MUH TYPE

- (1) Turn off the main power for the unit.
- (2) Pull out the electronic control P.C. board (Refer to page 59.), and change switch (SW2-②) on the indoor electronic control P.C. board according to the type of outdoor unit as following figures.

Outdoor unit MU type
Set ② switch upside.

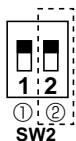

Outdoor unit MUH type
Set ② switch downside.



SW2-① sets the AUTO RESTART FUNCTION ON / OFF.
SW2-② switches over the MU type/ MUH type.

When the units are shipped from the factory, SW2 is as follows.
SW2-①: AUTO RESTART FUNCTION OFF
SW2-②: MUH type

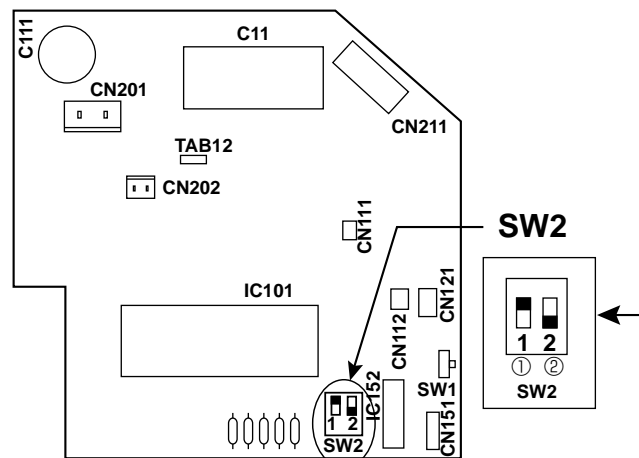

INDOOR ELECTRIC CONTROL P.C. BOARD

NOTE: •If the indoor-outdoor connecting wire is incorrectly connected on the terminal block, the unit does not operate normally.

•If a ground is incorrect, it may cause an electric shock.

2. AUTO RESTART FUNCTION

When the indoor unit is controlled with the remote controller, the operation mode, set temperature, and the fan speed are memorized by the indoor electronic control P.C.board. The "AUTO RESTART FUNCTION" sets to work the moment power has restored after power failure. Then, the unit will restart automatically. However if the unit is operated in "I FEEL CONTROL" mode before power failure, the operation is not memorized. In "I FEEL CONTROL" mode, the operation is decided by the initial room temperature. "AUTO RESTART FUNCTION" is OFF when the units are shipped from the factory.

How to set "AUTO RESTART FUNCTION"

- (1) Turn off the main power for the unit.
- (2) Pull out the electronic control P.C. board, and change switch(SW2-①) on the indoor electronic control P.C. board as follow figures.

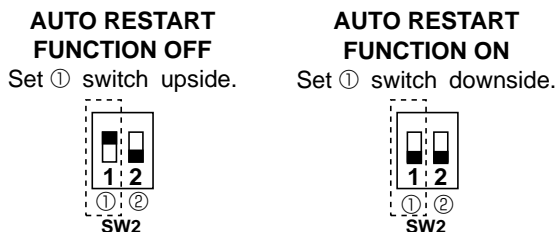

Operation

- (1) If the main power (230V AC) has been cut, the operation settings remain.
- (2) After the power is restored, the unit restarts automatically according to the memory.(However, it takes at least 3 minutes for the compressor to start running.)

NOTE:

- The operation settings are memorized when 10 seconds have passed after indoor unit was operated with the remote controller.
- If the main power is turned off or a power failure occurs while AUTO START/STOP timer is active, the timer setting is cancelled.
- If the unit has been off with the remote controller before power failure, the auto restart function does not work as the power button of the remote controller is off.
- To prevent breaker off due to the rush of starting current, systematize other home appliance not to turn on at the same time.
- When some air conditioners are connected to the same supply system, if they are operated before power failure, the starting current of all the compressors may flow simultaneously at restart. Therefore, the special counter-measures are required to prevent the main voltage-drop or the rush of the starting current by adding to the system that allows the units to start one by one.

MSC-C07TV -E1 MU-C07TV -E1 MUH-C07TV -E1

MSC-C09TV -E1 MU-C09TV -E1 MUH-C09TV -E1

MSC-C12TV -E1 MU-C12TV -E1 MUH-C12TV -E1

11-1. Cautions on troubleshooting

1. Before troubleshooting, check the following:

- 1) Check the power supply voltage.
- 2) Check the indoor/outdoor connecting wire for mis-wiring.

2. Take care the following during servicing.

- 1) Before servicing the air conditioner, be sure to first turn off the remote controller to stop the main unit, and then after confirming the horizontal vane is closed, turn off the breaker and / or disconnect the power plug.
- 2) Be sure to turn OFF the power supply before removing the front panel, the cabinet, the top panel, and the electronic control P.C. board.
- 3) When removing the electronic control P.C. board, hold the edge of the board with care NOT to apply stress on the components.
- 4) When connecting or disconnecting the connectors, hold the housing of the connector. DO NOT pull the lead wires.

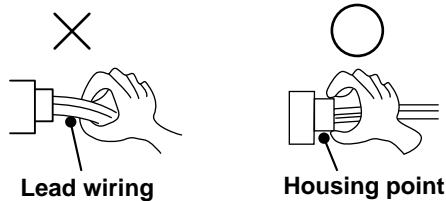

3. Troubleshooting procedure

- 1) First, check if the OPERATION INDICATOR lamp on the indoor unit is flashing on and off to indicate an abnormality. To make sure, check how many times the abnormality indication is flashing on and off before starting service work.
- 2) Before servicing check that the connector and terminal are connected properly.
- 3) If the electronic control P.C. board is supposed to be defective, check the copper foil pattern for disconnection and the components for bursting and discoloration.
- 4) When troubleshooting, refer to the flow chart on page 49 and the check table on page 50.

4. How to replace batteries

Weak batteries may cause the remote controller malfunction.

In this case, the remote controller can be repaired only by the battery replacement. To operate the remote controller normally, replace the batteries in the following order.

This remote controller has the RESET button. After refilling new batteries, press the RESET button with tip end of ball point pen or the like, and then use the remote controller.

- ① Remove the front lid and insert batteries. Then reattach the front lid.

- ② Press the RESET button.

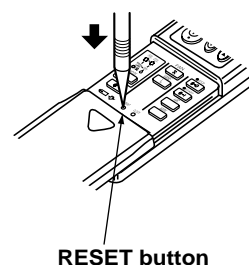
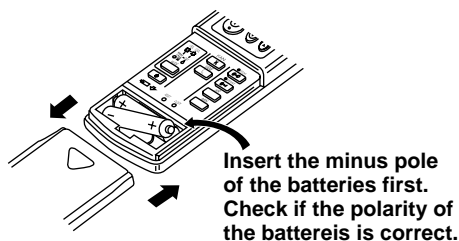

NOTE : If the RESET button is not pressed, the remote controller may not operate correctly.

11-2. Instruction of troubleshooting

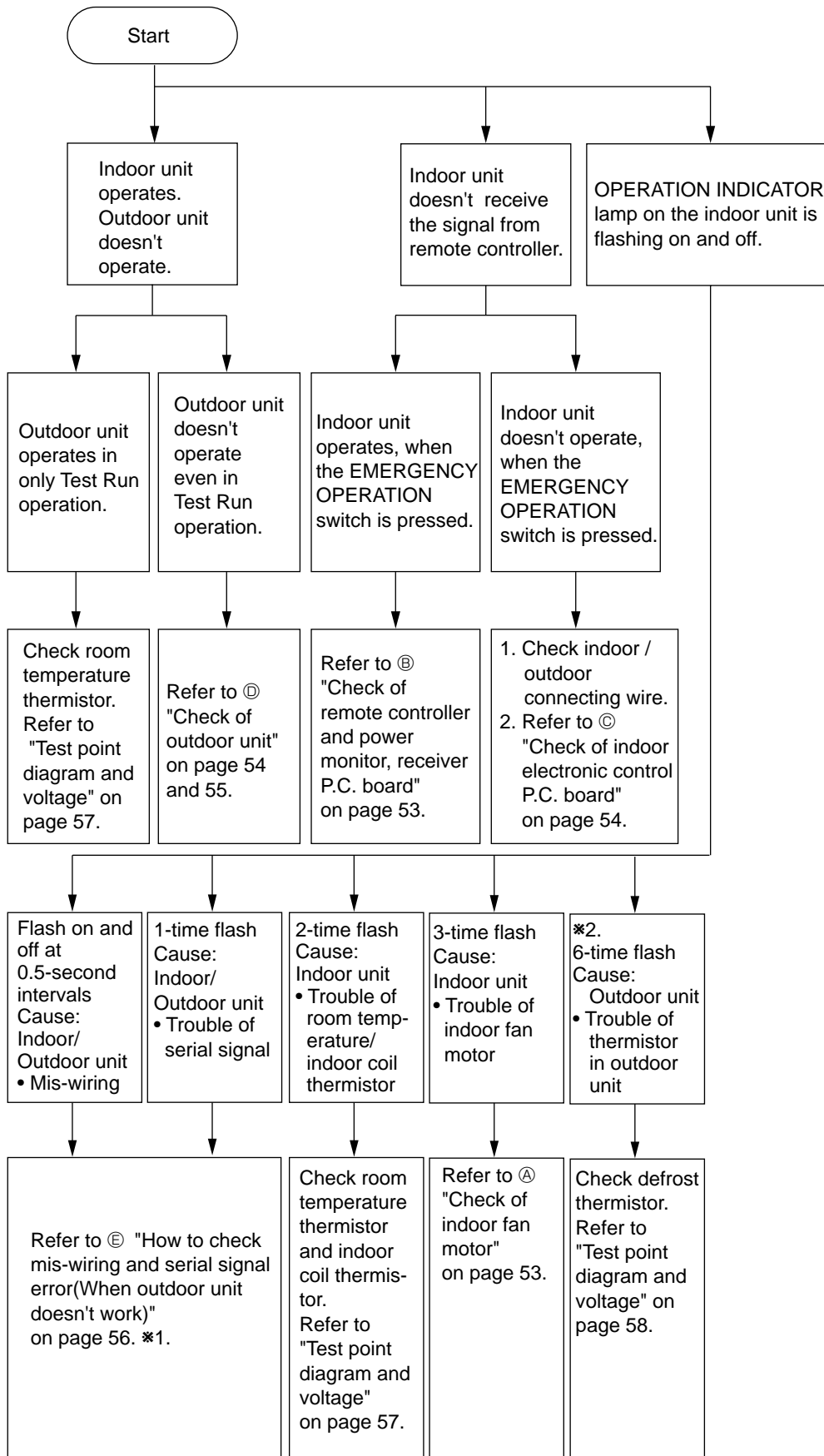

※1.<The case of the trouble of the serial signal>

When the power is turned off and then turned on again, the indication shows "the trouble of mis-wiring".

※2.This indication is only for MUH-C07/C09/C12TV -[E].

1. troubleshooting check table

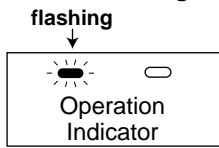

- Flashing of the OPERATION INDICATOR lamp (on the left-hand side) indicates possible abnormalities.
- The OPERATION INDICATOR lamp (on the left-hand side) is lighting during normal operation.

※ Before taking measures, make sure that the symptom reappears, for accurate troubleshooting.

Self check table

NO.	Abnormal point	Indication	Symptom	Detect method	Check point
1	Mis-wiring	0.5-second ON ●○○●○○●○○●○○ 0.5-second OFF	Outdoor unit does not run.	When serial signal stops for 4 to 5 seconds after 1st on of 52C relay by POWER turning on.	<ul style="list-style-type: none"> ● Check switch SW2-②.(MU type or MUH type) ● Check wiring (visual check and conductivity check). ● Check indoor electronic control P.C.board. ● Check outdoor DEICER P.C. board. ● Check electrical parts.
	Serial signal	1-time flash ●○○○○○○●○○○○○○○○●○○○○ 2.5-second OFF		When serial signal from outdoor unit stops for 4 to 5 seconds.	
2	Indoor coil thermistor Room temperature thermistor	2-time flash ●○○●○○○○○○●○○●○○○ 2.5-second OFF	Outdoor unit does not run.	Detect Indoor coil/room temperature thermistor short or open circuit every 8 seconds during operation.	<ul style="list-style-type: none"> ● Check resistance of thermistor. ● Reconnect connector. ● Check indoor electronic control P.C.board.
3	Indoor fan motor	3-time flash ●○○●○○○○○○●○○●○○●○○○○ 2.5-second OFF	Indoor fan motor repeats 12 seconds ON and 3 minutes OFF. When the indoor fan motor breaks, the fan keeps stopping.	When rotational frequency feedback pulse signal is not emit during 12-second indoor fan operation.	<ul style="list-style-type: none"> ● Disconnect connector CN211 and then check connector CN121 ②-③ to make sure rotational frequency feedback signal of 1.5V or over exists. ● Check indoor electronic control P.C. board. ● Check indoor fan motor. ● Reconnect connector.
4	Defrost thermistor ※	6-time flash ●○○●○○●○○●○○○○○○●○○ 2.5-second OFF	Outdoor unit does not run.	When the defrost thermistor shorts or opens after the compressor start-up.	<ul style="list-style-type: none"> ● Check outdoor DEICER P.C. board. ● Check resistance of thermistor. ● Reconnect connector.

NOTE: ※ This indication is only for MUH-C07/C09/C12TV -[E].

2. Trouble criterion of main parts

MSC-C07TV -**E1**

MSC-C09TV -**E1**

MSC-C12TV -**E1**

Part name	Check method and criterion		Figure										
Room temperature thermistor(RT11)	Measure the resistance with a tester. (Part temperature 10°C ~ 30°C)												
Indoor coil thermistor(RT12)	<table border="1" style="width: 100%;"> <tr> <td style="width: 50%;">Normal</td> <td style="width: 50%;">Abnormal</td> </tr> <tr> <td>MSC-C07/C09/C12TV</td> <td rowspan="2">Open or short-circuit</td> </tr> <tr> <td>8kΩ ~ 20kΩ</td> </tr> </table>	Normal		Abnormal	MSC-C07/C09/C12TV	Open or short-circuit	8kΩ ~ 20kΩ						
Normal	Abnormal												
MSC-C07/C09/C12TV	Open or short-circuit												
8kΩ ~ 20kΩ													
Indoor fan motor(MF)	Motor part Measure the resistance between the terminals with a tester. (Coil wiring temperature 10°C ~ 30°C)	<table border="1" style="width: 100%;"> <tr> <td style="width: 30%;"></td> <td style="width: 40%;">Normal</td> <td style="width: 30%;">Abnormal</td> </tr> <tr> <td></td> <td>MSC-C07/C09/C12TV</td> <td rowspan="3">Open or short-circuit</td> </tr> <tr> <td>WHT-BLK</td> <td>280 ~ 304Ω</td> </tr> <tr> <td>BLK-RED</td> <td>311 ~ 338Ω</td> </tr> </table>		Normal	Abnormal		MSC-C07/C09/C12TV	Open or short-circuit	WHT-BLK	280 ~ 304Ω	BLK-RED	311 ~ 338Ω	
		Normal	Abnormal										
	MSC-C07/C09/C12TV	Open or short-circuit											
WHT-BLK	280 ~ 304Ω												
BLK-RED	311 ~ 338Ω												
Sensor part Measure the voltage Power ON.	<table border="1" style="width: 100%;"> <tr> <td style="width: 30%;"></td> <td style="width: 40%;">Normal</td> <td style="width: 30%;">Abnormal</td> </tr> <tr> <td></td> <td>MSC-C07/C09/C12TV</td> <td rowspan="3">Remain 0V or 5V</td> </tr> <tr> <td>BRN-YLW</td> <td>4.5 ~ 5.5V</td> </tr> <tr> <td>YLW-GRY</td> <td>(When fan revolved one time) 0V→5V→0V (Approx.)</td> </tr> </table>		Normal	Abnormal		MSC-C07/C09/C12TV	Remain 0V or 5V	BRN-YLW	4.5 ~ 5.5V	YLW-GRY	(When fan revolved one time) 0V→5V→0V (Approx.)		
	Normal	Abnormal											
	MSC-C07/C09/C12TV	Remain 0V or 5V											
BRN-YLW	4.5 ~ 5.5V												
YLW-GRY	(When fan revolved one time) 0V→5V→0V (Approx.)												
Vane motor(MV)	Measure the resistance between the terminals with a tester. (Part temperature 10°C ~ 30°C)	<table border="1" style="width: 100%;"> <tr> <td style="width: 50%;">Normal</td> <td style="width: 50%;">Abnormal</td> </tr> <tr> <td>MSC-C07/C09/C12TV</td> <td rowspan="2">Open or short-circuit</td> </tr> <tr> <td>282 ~ 306Ω</td> </tr> </table>	Normal	Abnormal	MSC-C07/C09/C12TV	Open or short-circuit	282 ~ 306Ω						
Normal	Abnormal												
MSC-C07/C09/C12TV	Open or short-circuit												
282 ~ 306Ω													

MU-C07TV -E1 MUH-C07TV -E1

MU-C09TV -E1 MUH-C09TV -E1

MU-C12TV -E1 MUH-C12TV -E1

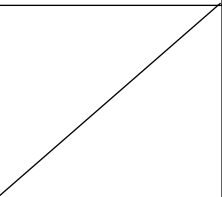
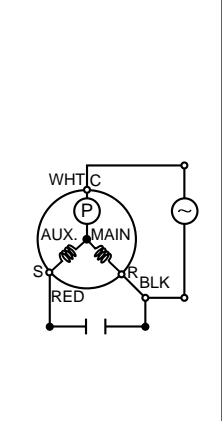
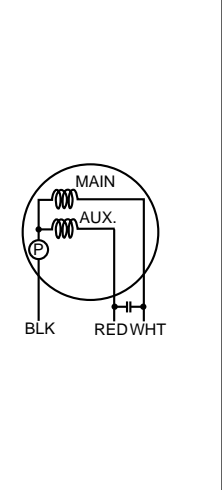
Part name	Check method and criterion	Figure																																		
Defrost thermistor(RT61) <MUH-C07/C09/C12TV>	<p>Measure the resistance with a tester. (Part temperature -10°C ~ 40°C)</p> <table border="1"> <thead> <tr> <th></th> <th>Normal</th> <th>Abnormal</th> </tr> </thead> <tbody> <tr> <td>MUH-C07/C09/C12TV</td> <td>5kΩ ~ 60kΩ</td> <td>Open or short-circuit</td> </tr> </tbody> </table>		Normal	Abnormal	MUH-C07/C09/C12TV	5kΩ ~ 60kΩ	Open or short-circuit																													
	Normal	Abnormal																																		
MUH-C07/C09/C12TV	5kΩ ~ 60kΩ	Open or short-circuit																																		
Compressor (MC)	<p>Measure the resistance between the terminals with a tester. (Coil wiring temperature -10°C ~ 40°C)</p> <table border="1"> <thead> <tr> <th rowspan="2"></th> <th colspan="3">Normal</th> <th rowspan="2">Abnormal</th> </tr> <tr> <th>MU-C07TV</th> <th>MU-C09TV</th> <th>MU-C12TV</th> </tr> </thead> <tbody> <tr> <td>C-R</td> <td>3.68~4.51Ω</td> <td>3.55~4.35Ω</td> <td>1.98~2.43Ω</td> <td rowspan="2">Open or short-circuit</td> </tr> <tr> <td>C-S</td> <td>5.08~6.22Ω</td> <td>5.03~6.16Ω</td> <td>3.59~4.39Ω</td> </tr> </tbody> </table> <table border="1"> <thead> <tr> <th rowspan="2"></th> <th colspan="3">Normal</th> <th rowspan="2">Abnormal</th> </tr> <tr> <th>MUH-C07TV</th> <th>MUH-C09TV</th> <th>MUH-C12TV</th> </tr> </thead> <tbody> <tr> <td>C-R</td> <td>3.68~4.51Ω</td> <td>2.91~3.56Ω</td> <td>1.98~2.43Ω</td> <td rowspan="2">Open or short-circuit</td> </tr> <tr> <td>C-S</td> <td>5.08~6.22Ω</td> <td>5.11~6.26Ω</td> <td>3.59~4.39Ω</td> </tr> </tbody> </table>		Normal			Abnormal	MU-C07TV	MU-C09TV	MU-C12TV	C-R	3.68~4.51Ω	3.55~4.35Ω	1.98~2.43Ω	Open or short-circuit	C-S	5.08~6.22Ω	5.03~6.16Ω	3.59~4.39Ω		Normal			Abnormal	MUH-C07TV	MUH-C09TV	MUH-C12TV	C-R	3.68~4.51Ω	2.91~3.56Ω	1.98~2.43Ω	Open or short-circuit	C-S	5.08~6.22Ω	5.11~6.26Ω	3.59~4.39Ω	
	Normal			Abnormal																																
	MU-C07TV	MU-C09TV	MU-C12TV																																	
C-R	3.68~4.51Ω	3.55~4.35Ω	1.98~2.43Ω	Open or short-circuit																																
C-S	5.08~6.22Ω	5.03~6.16Ω	3.59~4.39Ω																																	
	Normal			Abnormal																																
	MUH-C07TV	MUH-C09TV	MUH-C12TV																																	
C-R	3.68~4.51Ω	2.91~3.56Ω	1.98~2.43Ω	Open or short-circuit																																
C-S	5.08~6.22Ω	5.11~6.26Ω	3.59~4.39Ω																																	
Outdoor fan motor(MF)	<p>Measure the resistance between the terminals with a tester. (Coil wiring temperature -10°C ~ 40°C)</p> <table border="1"> <thead> <tr> <th rowspan="2"></th> <th colspan="2">Normal</th> <th rowspan="2">Abnormal</th> </tr> <tr> <th>MU-C07/C09TV</th> <th>MU-C12TV</th> </tr> </thead> <tbody> <tr> <td>WHT-BLK</td> <td>227~279Ω</td> <td>155 ~ 191Ω</td> <td rowspan="2">Open or short-circuit</td> </tr> <tr> <td>BLK-RED</td> <td>339~416Ω</td> <td>363 ~ 445Ω</td> </tr> </tbody> </table> <table border="1"> <thead> <tr> <th rowspan="2"></th> <th colspan="2">Normal</th> <th rowspan="2">Abnormal</th> </tr> <tr> <th>MUH-C07TV</th> <th>MUH-C09/C12TV</th> </tr> </thead> <tbody> <tr> <td>WHT-BLK</td> <td>227~279Ω</td> <td>155 ~ 191Ω</td> <td rowspan="2">Open or short-circuit</td> </tr> <tr> <td>BLK-RED</td> <td>339~416Ω</td> <td>363 ~ 445Ω</td> </tr> </tbody> </table>		Normal		Abnormal	MU-C07/C09TV	MU-C12TV	WHT-BLK	227~279Ω	155 ~ 191Ω	Open or short-circuit	BLK-RED	339~416Ω	363 ~ 445Ω		Normal		Abnormal	MUH-C07TV	MUH-C09/C12TV	WHT-BLK	227~279Ω	155 ~ 191Ω	Open or short-circuit	BLK-RED	339~416Ω	363 ~ 445Ω									
	Normal		Abnormal																																	
	MU-C07/C09TV	MU-C12TV																																		
WHT-BLK	227~279Ω	155 ~ 191Ω	Open or short-circuit																																	
BLK-RED	339~416Ω	363 ~ 445Ω																																		
	Normal		Abnormal																																	
	MUH-C07TV	MUH-C09/C12TV																																		
WHT-BLK	227~279Ω	155 ~ 191Ω	Open or short-circuit																																	
BLK-RED	339~416Ω	363 ~ 445Ω																																		

Ⓟ INNER PROTECTOR

A Check of indoor fan motor

Indoor fan motor doesn't operate.

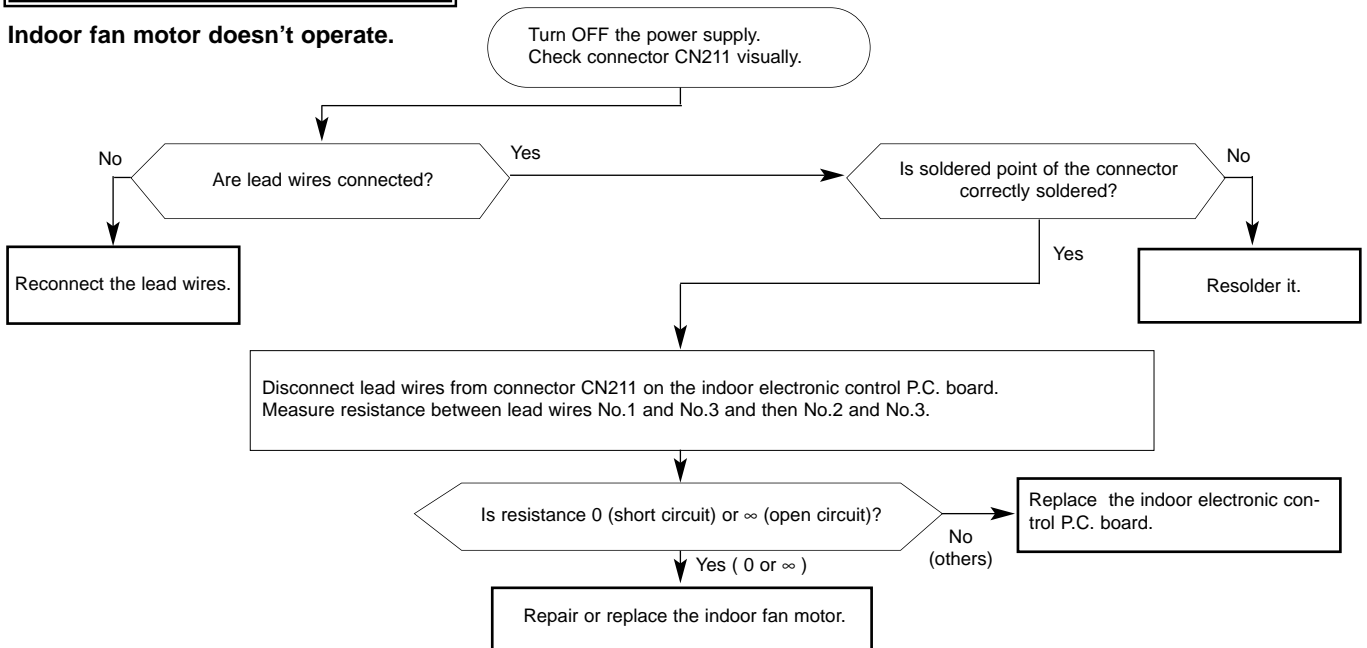

B Check of remote controller and power monitor, receiver P.C. board

Indoor unit operates by pressing the EMERGENCY OPERATION switch, but doesn't operate with the remote controller.

※Check the remote controller is exclusive for this air conditioner.

※In case of replacing the power monitor, receiver P.C. board, replace the indoor electronic control P.C. board with it because they are unified.

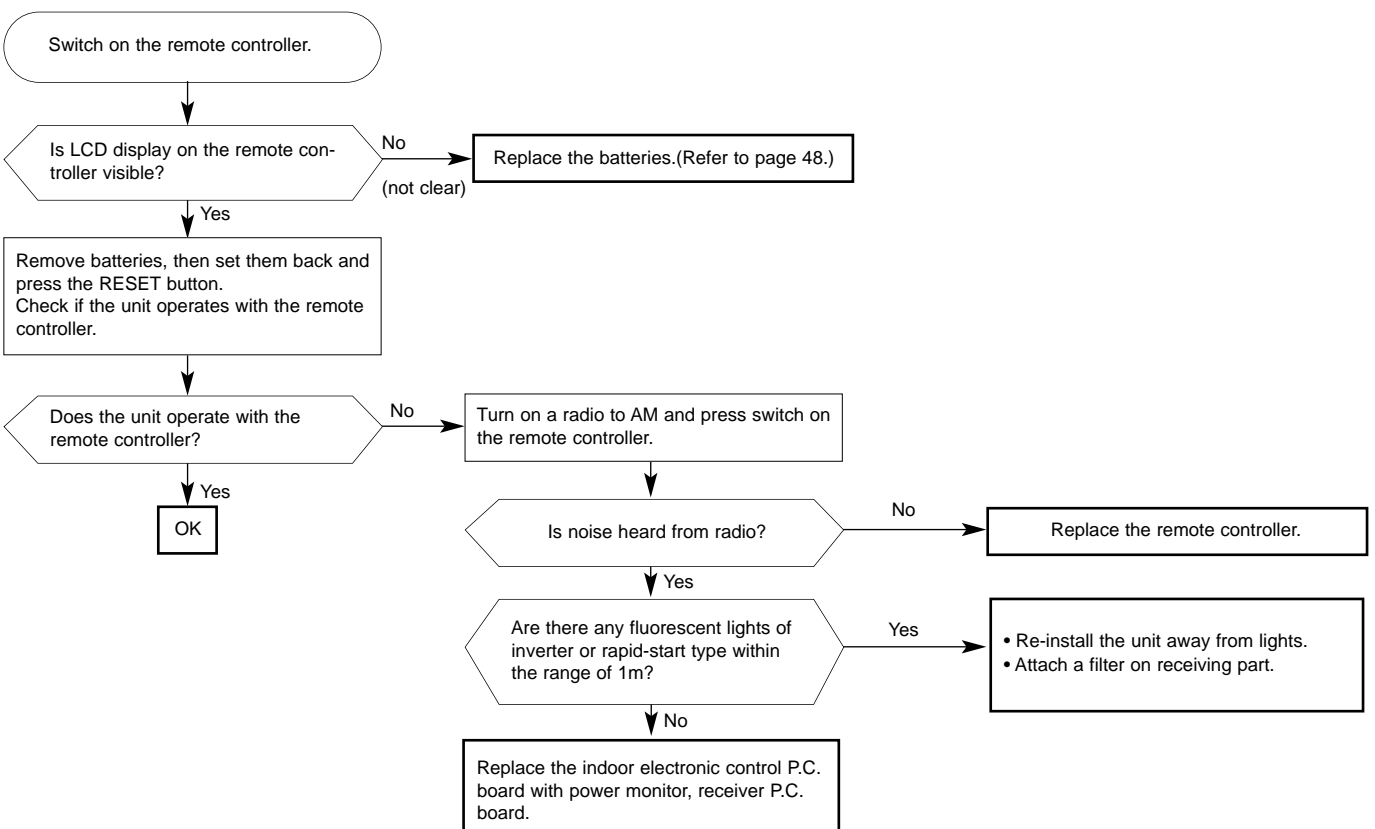

© Check of indoor electronic control P.C. board

The unit doesn't operate with the remote controller.

Also, the OPERATION INDICATOR lamp doesn't light up by pressing the EMERGENCY OPERATION switch.

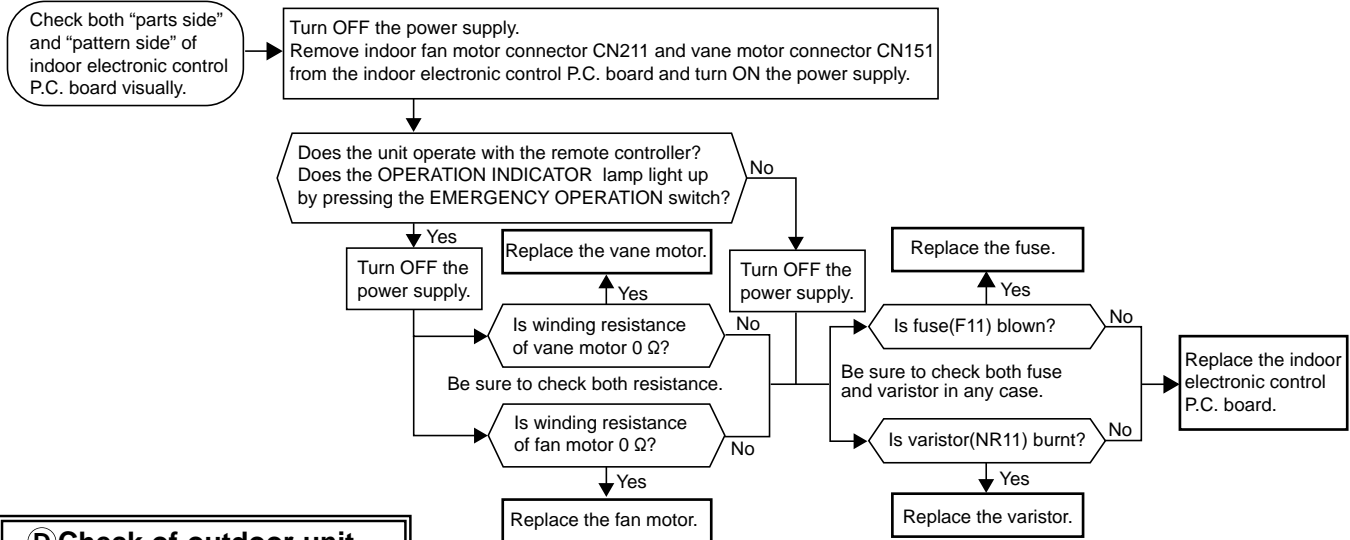

© Check of outdoor unit

Compressor and / or outdoor fan motor doesn't operate.

<MU-C07/C09/C12TV>

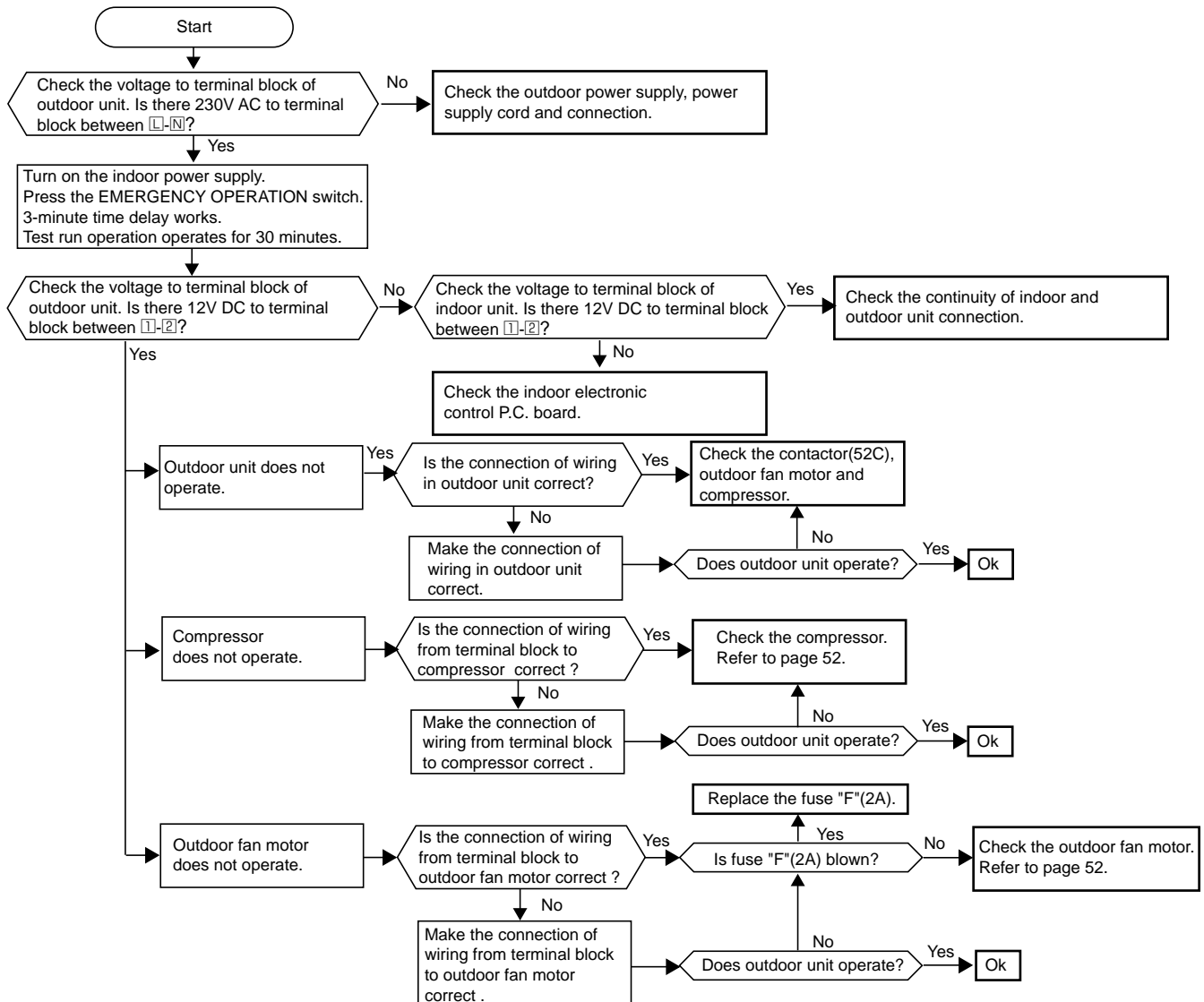

<MUH-C07/C09/C12TV>

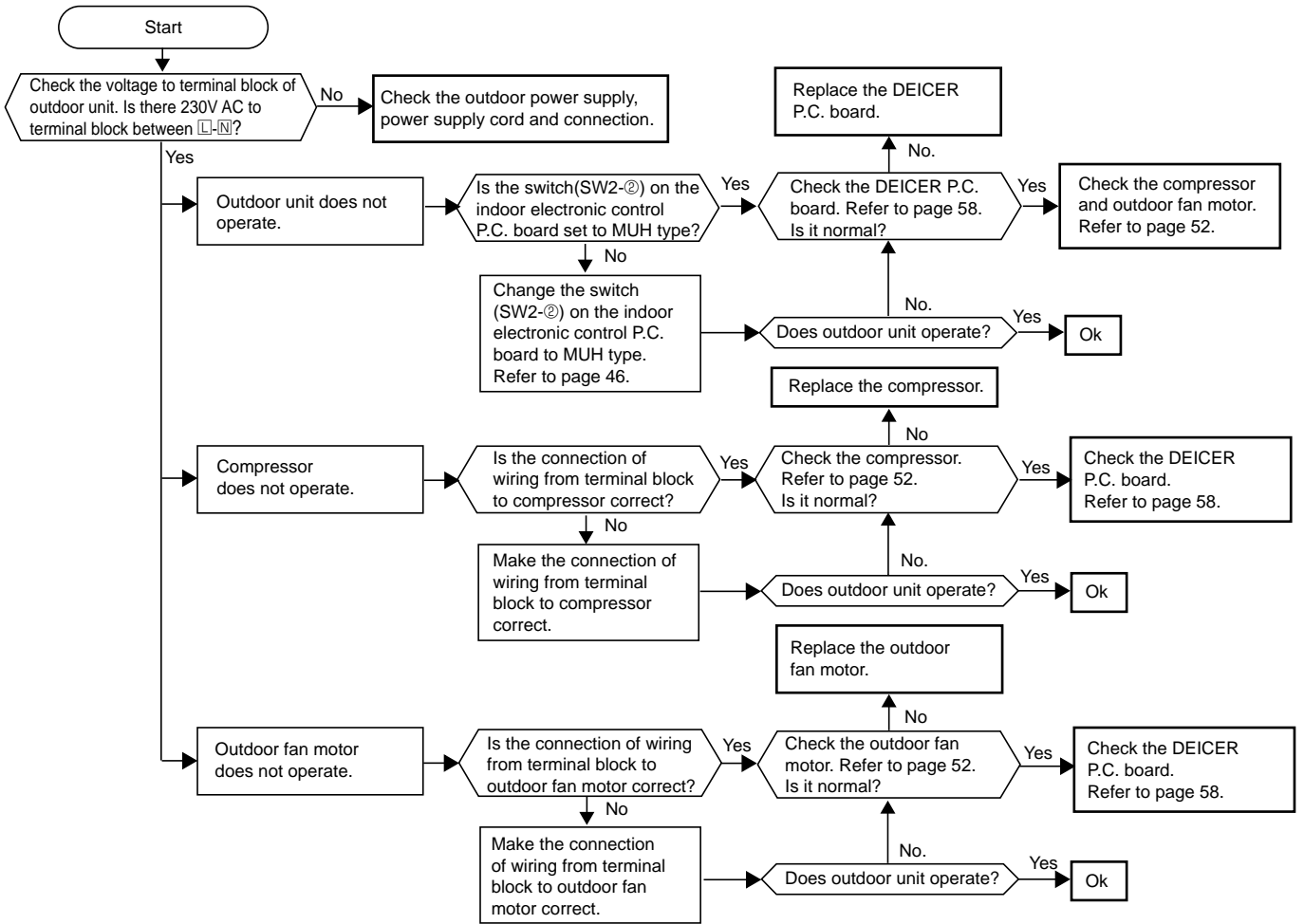

E How to check mis-wiring and serial signal error

Outdoor unit doesn't operate.

※1 Set the switch(SW2-②) on the indoor electronic control P.C. board to MU type, when the outdoor unit is MU type. If the setting is MUH type, the unit does not work.

※2 Short circuit of JPG and JPS on the indoor electronic control P.C. board enables self-check to be displayed in 3 seconds.

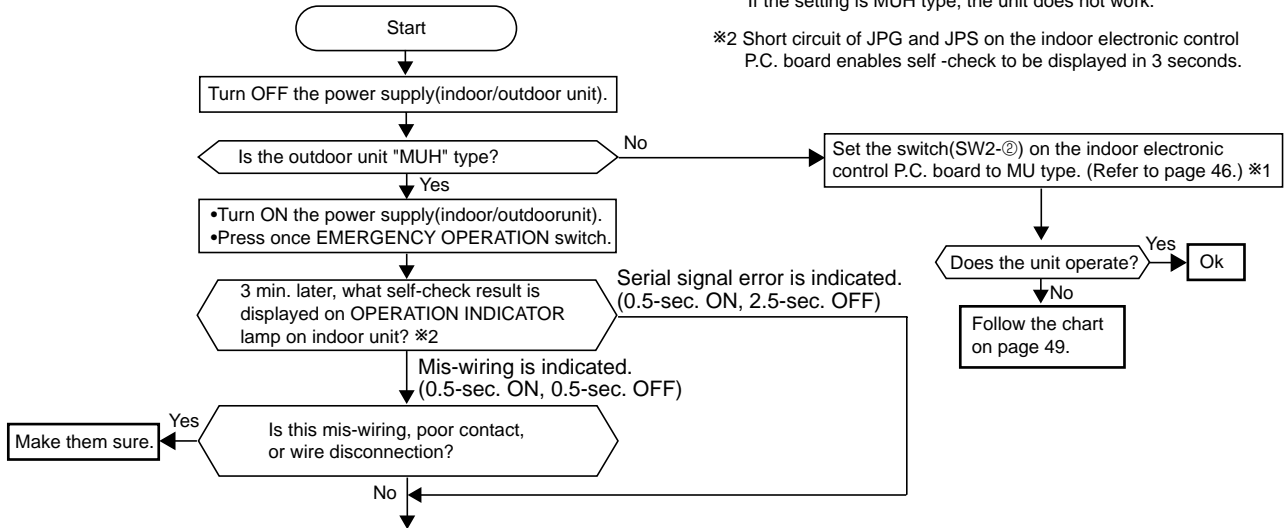

1. Turn OFF the power supply(indoor/outdoor unit) and disconnect in-out connecting wire on indoor side.
2. Short-circuit between indoor terminal block N and 3.
3. Turn ON the power supply(indoor unit) and press once EMERGENCY OPERATION switch.

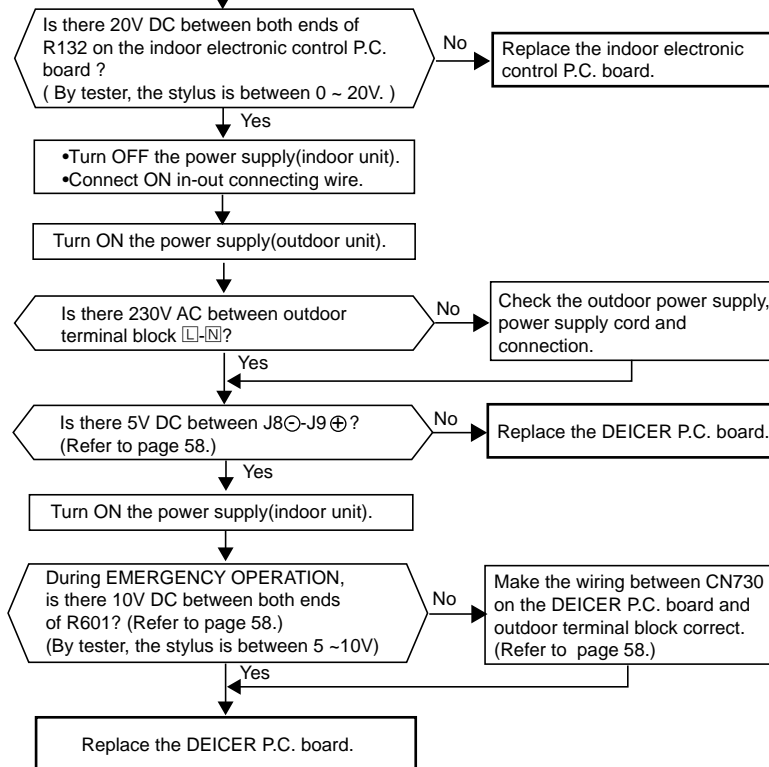

TEST POINT DIAGRAM AND VOLTAGE

MSC-C07TV -E1

MSC-C09TV -E1

MSC-C12TV -E1

Indoor electronic control P.C. board

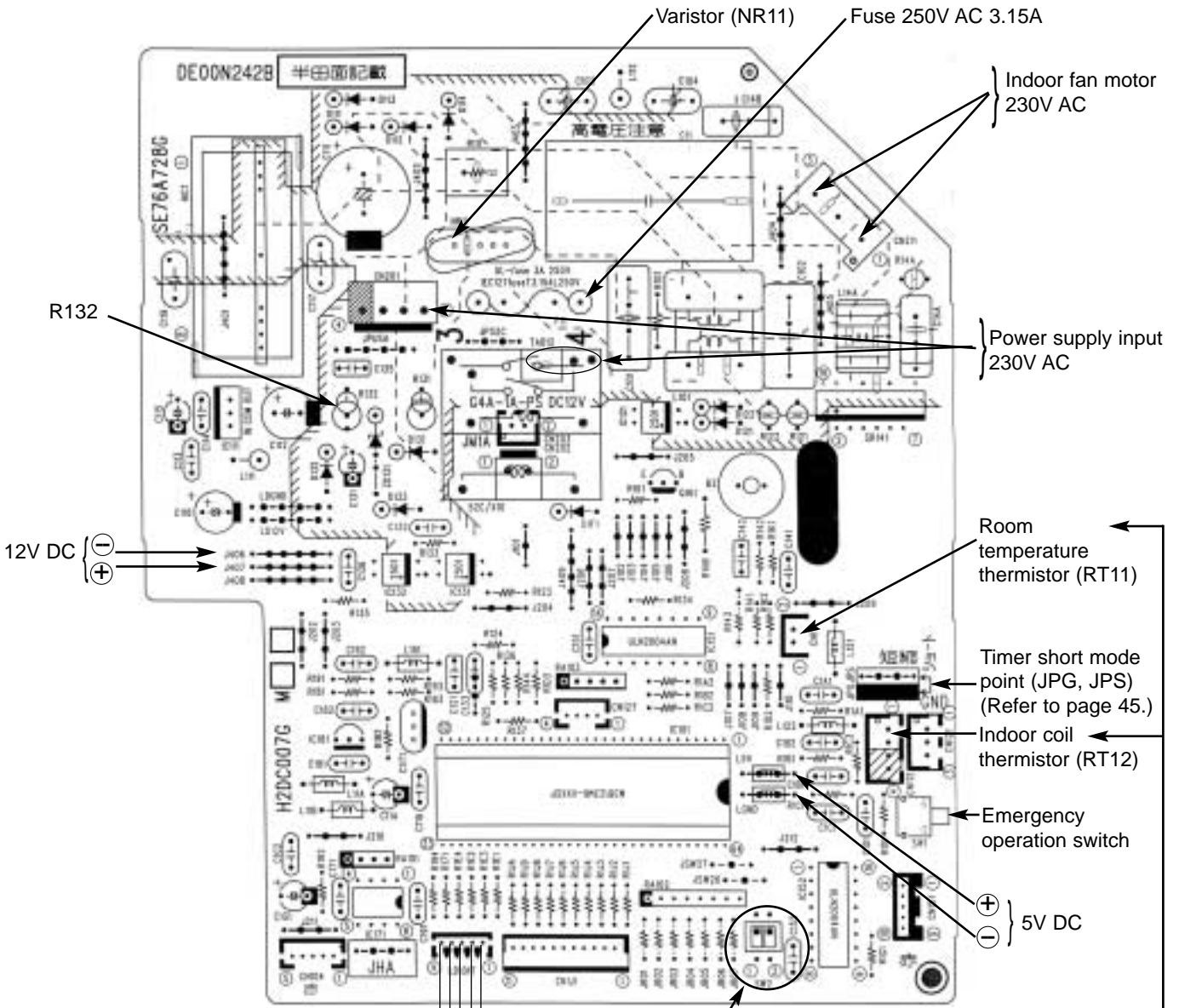

SW2 (Refer to page 46.)
 ① sets the Auto restart function ON/ OFF.
 ② switches over MU type/ MUH type.

Indoor coil thermistor (RT12)
 Room temperature thermistor (RT11)

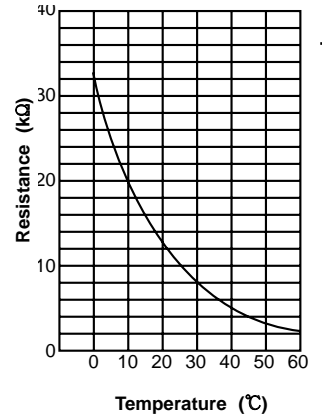

MUH-C07TV -E1
MUH-C09TV -E1
MUH-C12TV -E1
Outdoor deicer P.C. board

Defrost thermistor (RT61)

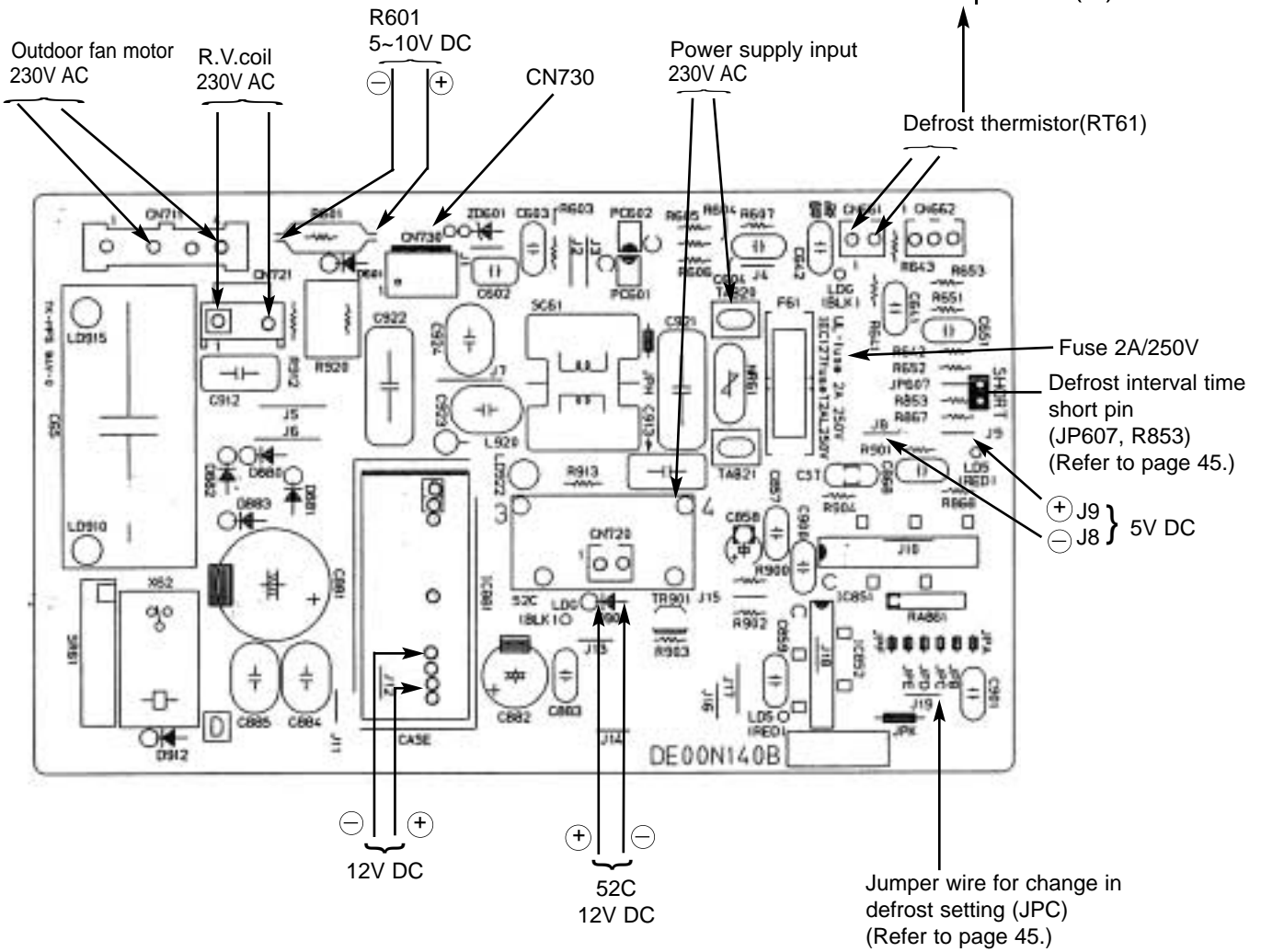
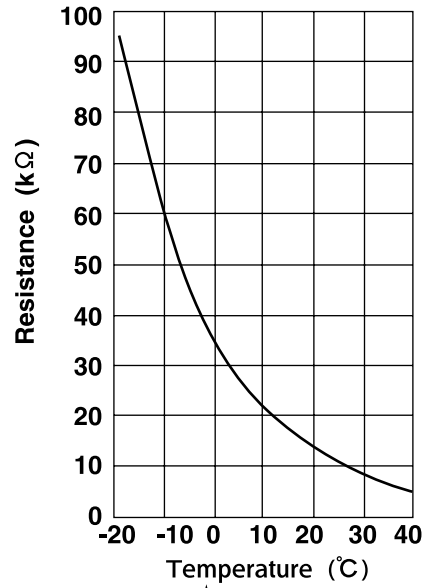

<"Terminal with lock mechanism" Detaching points>

In case of terminal with lock mechanism, detach the terminal as shown below.
There are two types (Refer to (1) and (2)) of the terminal with lock mechanism.
The terminal with no lock mechanism can be removed by pulling it out.
Check the shape of the terminal and work.

(1) Slide the sleeve and check if there is a locking lever or not.

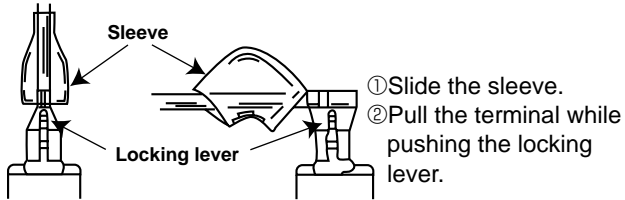

(2) The terminal with this connector is a terminal with lock mechanism.

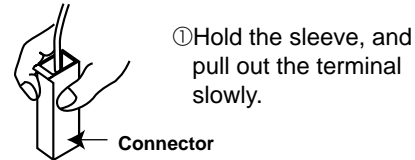

12-1. MSC-C07TV -[E1] MSC-C09TV -[E1] MSC-C12TV -[E1] INDOOR UNIT

OPERATING PROCEDURE	PHOTOS
<p>1. Removing the front panel</p> <p>(1) Remove the screw caps of the front panel. Remove the screws.</p> <p>(2) Pull the panel down to your side slightly and unhook the catches at the top.</p>	<p>Photo 1</p> <p>Front panel</p> <p>Screws</p>
<p>2. Removing the electronic control P.C. board and the power monitor, receiver P.C. board</p> <p>(1) Remove the front panel. (Refer to 1)</p> <p>(2) Remove the screw of the electrical cover. Remove the electrical cover.</p> <p>(3) Remove the V.A. clamp.</p> <p>(4) Remove the cord clamp.</p> <p>(5) Remove the screw of the terminal block.</p> <p>(6) Remove the screw of the ground wire.</p> <p>(7) Disconnect all the connectors and all the lead wires on the electronic control P.C. board.</p> <p>(8) Remove the R.L holder.</p> <p>(9) Remove the electronic control P.C. board.</p> <p>(10) Open the R.L holder and the power monitor, receiver P.C. board.</p>	<p>Photo 2</p> <p>Screw of the ground wire</p> <p>Fan motor connector</p> <p>V.A. clamp</p> <p>Room temperature thermistor connector</p> <p>Indoor electronic control P.C. board</p> <p>Vane motor connector</p> <p>Cord clamp</p> <p>R.L holder</p> <p>Power monitor, receiver P.C. board</p> <p>Screw of the V.A. clamp</p>

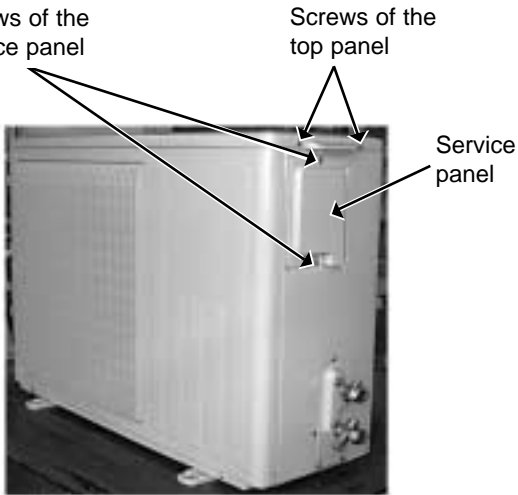
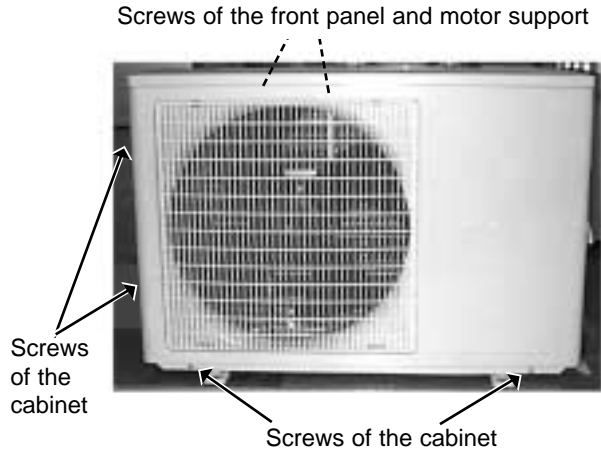
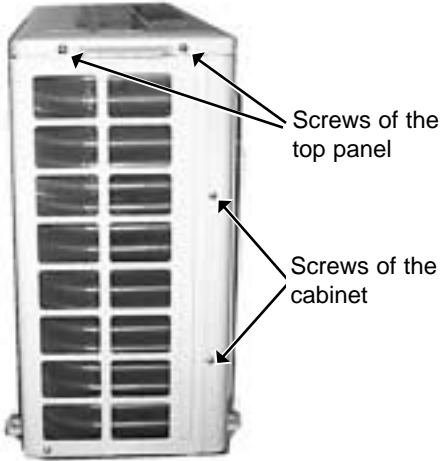
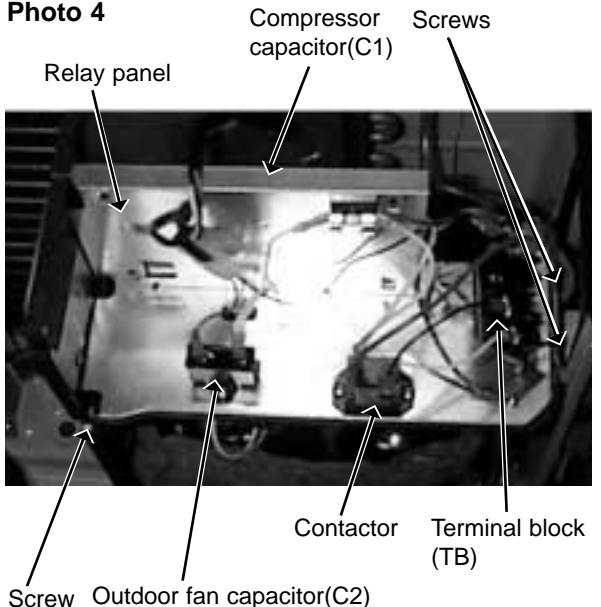

12-2. MU-C07TV -E1 MU-C09TV -E1 MU-C12TV -E1
OUTDOOR UNIT

OPERATING PROCEDURE	PHOTOS
<p>1. Removing the cabinet</p> <ol style="list-style-type: none"> (1) Remove the screws of the top panel. (2) Remove the screw of the service panel. (3) Remove the screws of the cabinet. (4) Remove the screws of the front panel and motor support. (5) Remove the service panel, and remove the screw from the insides. (6) Remove the top panel. (7) Remove the cabinet. <p>Photo 3</p>  <p>Screws of the service panel Screws of the top panel</p> <p>Service panel</p>	<p>Photo 1</p>  <p>Screws of the front panel and motor support</p> <p>Screws of the cabinet</p> <p>Screws of the cabinet</p> <p>Photo 2</p>  <p>Screws of the top panel</p> <p>Screws of the cabinet</p>
<p>2. Removing the electrical parts</p> <ol style="list-style-type: none"> (1) Remove the service panel and the cabinet.(Refer to 1) (2) Remove the following parts. <ul style="list-style-type: none"> •Compressor capacitor (C1) •Outdoor fan capacitor (C2) •Terminal block (TB) 	<p>Photo 4</p>  <p>Relay panel Compressor capacitor(C1) Screws</p> <p>Screw Outdoor fan capacitor(C2) Contactor Terminal block (TB)</p>

OPERATING PROCEDURE

3. Removing the propeller fan and the outdoor fan motor

- (1) Remove the cabinet. (Refer to 1)
- (2) Remove the propeller fan nut.
- (3) Remove the propeller fan.

NOTE : Loose the propeller fan in the rotating direction for removal.

When attaching the propeller fan, align the mark on the propeller fan and the motor shaft cut section.

Set the propeller fan in position by using the cut on the shaft and the mark on the propeller fan.

- (4) Remove lead clamps and disconnect the outdoor fan motor connector.
- (5) Remove screws fixing the fan motor.
- (6) Remove the outdoor fan motor.

PHOTOS

Photo 5

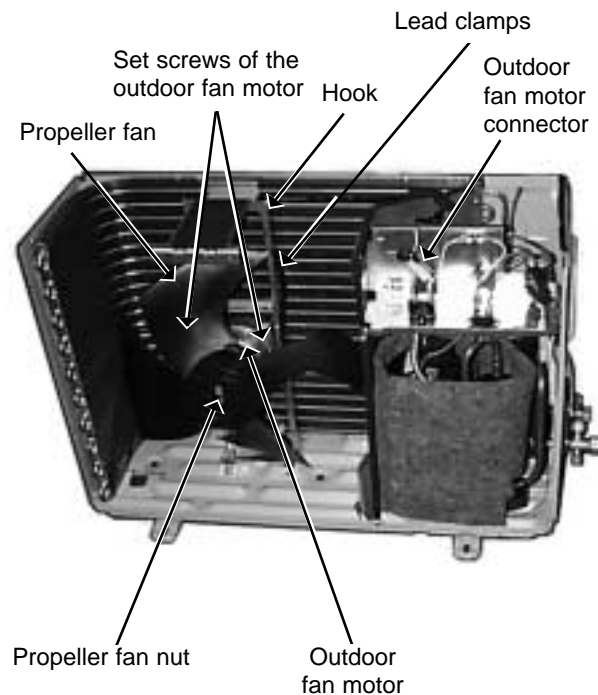

4. Removing the compressor

- (1) Remove the cabinet. (Refer to 1)
- (2) Remove the relay panel.
- (3) Remove the soundproof felt.
- (4) Remove the terminal cover on the compressor.
- (5) Disconnect lead wires from the glass terminal of the compressor.
- (6) Recover gas from the refrigerant circuit.
- (7) Disconnect the welded part of the discharge pipe.
- (8) Disconnect the welded part of the suction pipe.
- (9) Remove nuts fixing the compressor.
- (10) Remove the compressor.

NOTE

- Before using a burner, reclaim gas from the pipes until the pressure gauge shows 0 kg/cm² (0MPa).
- Use the burner under the condition that gas can be recovered even when the inner pressure rises by heat.

Photo 6

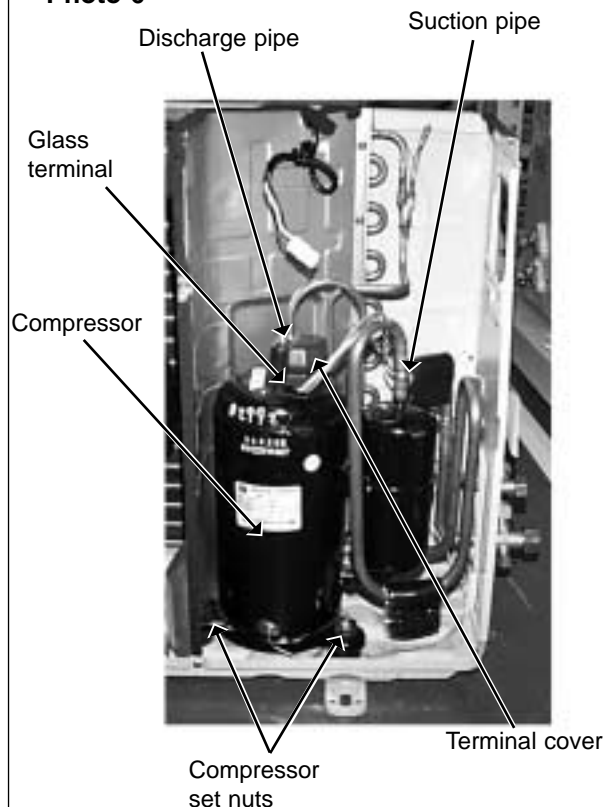

12-3. MUH-C07TV -E1 MUH-C09TV -E1 MUH-C12TV -E1
OUTDOOR UNIT

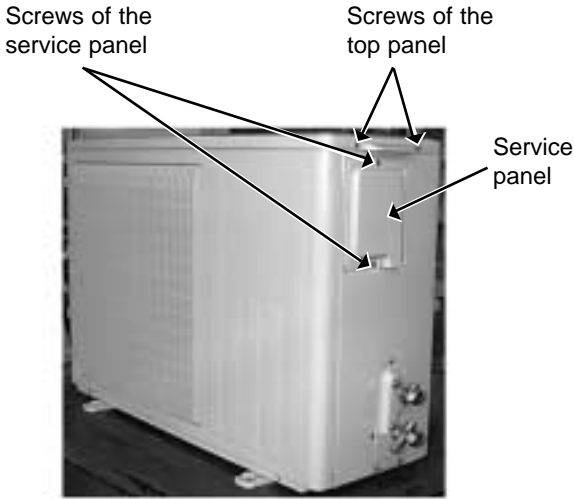
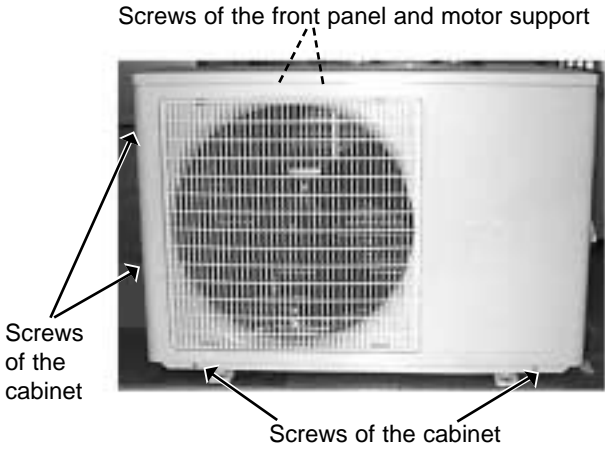
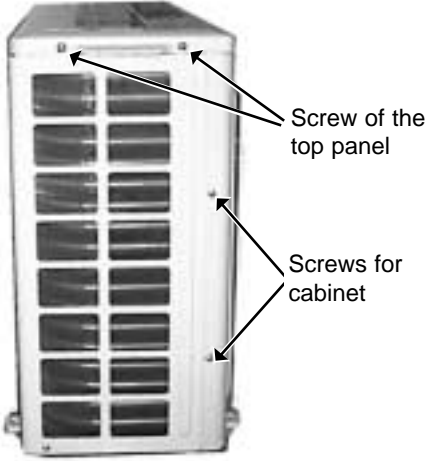
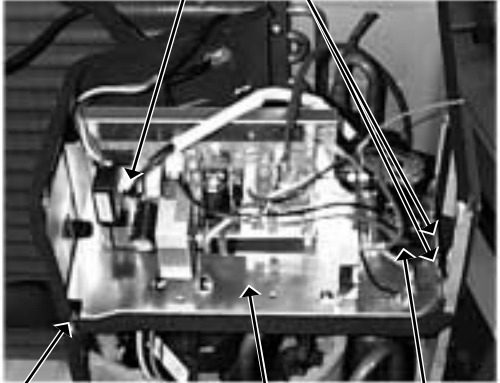
OPERATING PROCEDURE	PHOTOS
<p>1. Removing the cabinet</p> <ol style="list-style-type: none"> (1) Remove the screws of the top panel. (2) Remove the screws of the service panel. (3) Remove the screws of the cabinet. (4) Remove the screws of the front panel and motor support. (5) Remove the service panel, and remove the screw from the insides. (6) Remove the top panel. (7) Remove the cabinet. <p>Photo 3</p>  <p>Screws of the service panel Screws of the top panel</p> <p>Service panel</p>	<p>Photo 1</p>  <p>Screws of the front panel and motor support</p> <p>Screws of the cabinet</p> <p>Screws of the cabinet</p> <p>Photo 2</p>  <p>Screw of the top panel</p> <p>Screws for cabinet</p>
<p>2. Removing the deicer P.C. board</p> <ol style="list-style-type: none"> (1) Remove the service panel and the cabinet. (2) Disconnect all the connectors and the terminals on the deicer P.C. board. (3) Remove the deicer P.C. board. 	<p>Photo 4</p>  <p>Deicer P.C. board Screws</p> <p>Screw</p> <p>Relay panel Terminal block(TB)</p>

OPERATING PROCEDURE

3. Removing the propeller fan and the outdoor fan motor

- (1) Remove the cabinet. (Refer to 1)
- (2) Remove the propeller fan nut.
- (3) Remove the propeller fan.

NOTE : Loose the propeller fan in the rotating direction for removal.

When attaching the propeller fan, align the mark on the propeller fan and the motor shaft cut section.

Set the propeller fan in position by using the cut on the shaft and the mark on the propeller fan.

- (4) Remove lead clamps and disconnect the outdoor fan motor connector.
- (5) Remove screws fixing the fan motor.
- (6) Remove the outdoor fan motor.

PHOTOS

Photo 5

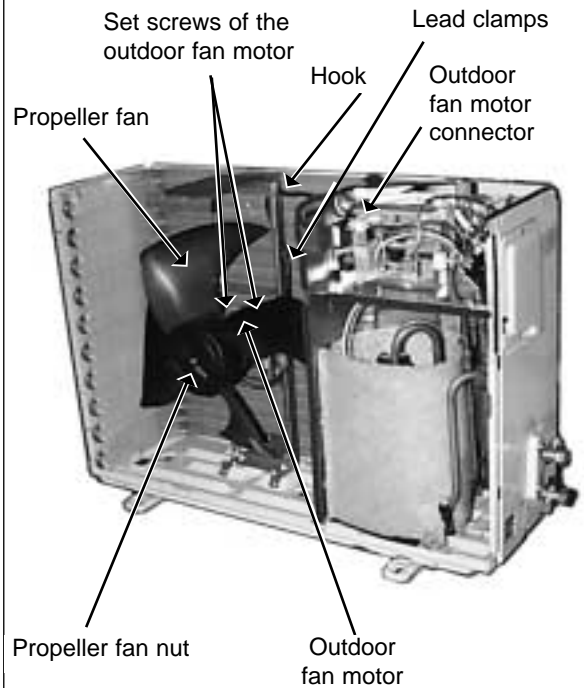

4. Removing the compressor

- (1) Remove the cabinet. (Refer to 1)
- (2) Remove the relay panel.
- (3) Remove the soundproof felt.
- (4) Remove the terminal cover on the compressor.
- (5) Disconnect lead wires from the glass terminal of the compressor.
- (6) Recover gas from the refrigerant circuit.
- (7) Disconnect the welded part of the discharge pipe.
- (8) Disconnect the welded part of the suction pipe.
- (9) Remove nuts fixing the compressor.
- (10) Remove the compressor.

NOTE

- Before using a burner, reclaim gas from the pipes until the pressure gauge shows 0 kg/cm² (MPa).
- Use the burner under the condition that gas can be recovered even when the inner pressure rises by heat.

Photo 6

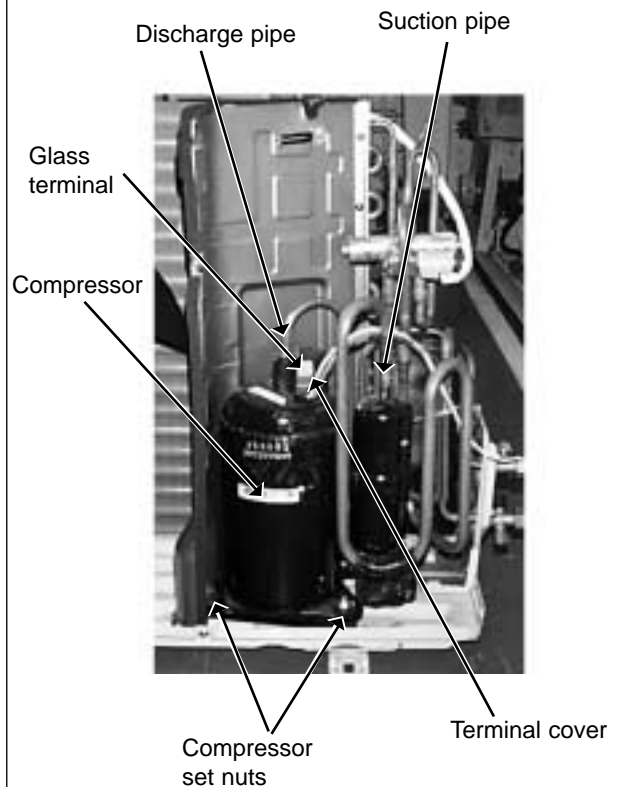

MSC-C07TV -E1 (WH)

MSC-C09TV -E1 (WH)

MSC-C12TV -E1 (WH)

13-1. INDOOR UNIT STRUCTURAL PARTS

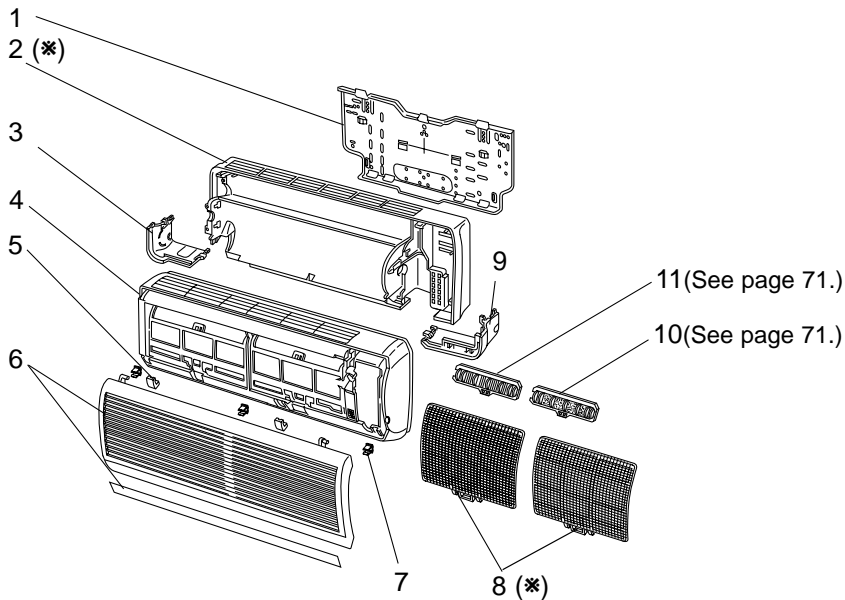

(*)These figures show about MSC-C12TV.

13-2. REMOTE CONTROLLER AND ACCESSORY PART

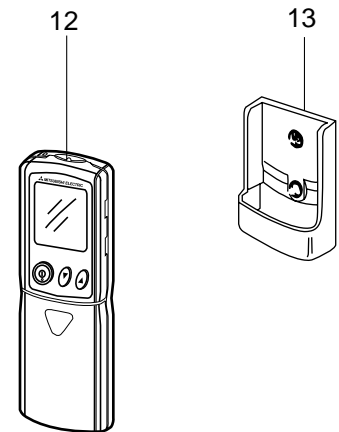

13-1. INDOOR UNIT STRUCTURAL PARTS

No.	Part No.	Part Name	Symbol in Wiring Diagram	Q'ty/unit			Remarks
				MSC-C07TV -E1 (WH)	MSC-C09TV -E1 (WH)	MSC-C12TV -E1 (WH)	
1	E02 408 970	INSTALLATION PLATE		1	1	1	
2	E02 409 234	BOX(WH)		1	1		
	E02 411 234	BOX(WH)				1	
3	E02 409 976	CORNER BOX LEFT(WH)		1	1	1	
4	E02 424 000	FRONT PANEL ASSEMBLY(WH)		1	1	1	Including No.5,6,7
5	E02 409 067	SCREW CAP(WH)		2	2	2	2PCS/SET
6	E02 424 010	GRILLE(WH)		1	1	1	
7	E02 408 142	CATCH		3	3	3	3PCS/SET
8	E02 408 100	AIR FILTER		2	2		
	E02 410 100	AIR FILTER				2	
9	E02 409 975	CORNER BOX RIGHT(WH)		1	1	1	
10	—————	DEODORIZING FILTER		1	1	1	MAC-1800DF
11	—————	AIR CLEANING FILTER		1	1	1	MAC-1300FT

13-2. REMOTE CONTROLLER AND ACCESSORY PART

12	E02 583 426	REMOTE CONTROLLER		1	1	1	
13	E02 527 083	REMOTE CONTROLLER HOLDER		1	1	1	

MSC-C07TV -[E1] (WH)

MSC-C09TV -[E1] (WH)

MSC-C12TV -[E1] (WH)

13-3. INDOOR UNIT FUNCTIONAL PARTS AND ELECTRICAL PARTS

13-4. INDOOR UNIT HEAT EXCHANGER

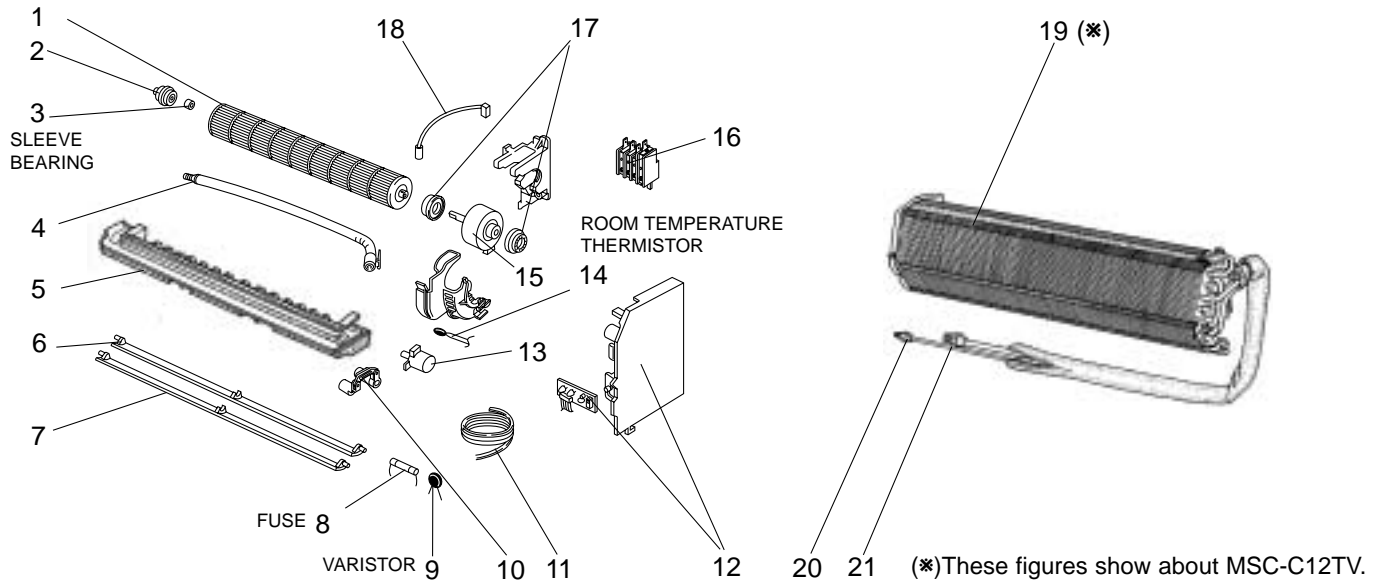

13-3. INDOOR UNIT FUNCTIONAL PARTS AND ELECTRICAL PARTS

No.	Part No.	Part Name	Symbol in Wiring Diagram	Q'ty/unit			Remarks
				MSC-C07TV -[E1](WH)	MSC-C09TV -[E1](WH)	MSC-C12TV -[E1](WH)	
1	E02 408 302	LINE FLOW FAN		1	1	1	
2	E02 408 509	BEARING MOUNT		1	1	1	
3	E02 001 504	SLEEVE BEARING		1	1	1	
4	E02 408 702	DRIAN HOSE		1	1	1	
5	E02 409 235	NOZZLE (WH)		1	1	1	
6	E02 409 040	VANE UPPER (WH)		1	1	1	
7	E02 409 041	VANE LOWER (WH)		1	1	1	
8	E02 127 382	FUSE	F11	1	1	1	3.15A
9	E02 336 385	VARISTOR	NR11	1	1	1	
10	E02 408 034	VANE CLANK SET		1	1	1	
11	E02 424 395	POWER SUPPLY CORD		1	1	1	
12	E02 608 452	ELECTRONIC CONTROL P.C.BOARD		1			AUTO RESTART
	E02 609 452	ELECTRONIC CONTROL P.C.BOARD			1		AUTO RESTART
	E02 610 452	ELECTRONIC CONTROL P.C.BOARD				1	AUTO RESTART
13	E02 408 303	VANE MOTOR	MV	1	1	1	
14	E02 408 308	ROOM TEMPERATURE THERMISTOR	RT11	1	1	1	
15	E02 151 300	INDOOR FAN MOTOR	MF	1	1	1	RC4V19- □□
16	E02 424 375	TERMINAL BLOCK	TB	1	1	1	3P
17	E02 151 505	FAN MOTOR RUBBER MOUNT		2	2	2	2PCS/SET
18	E02 408 307	INDOOR COIL THERMISTOR	RT12	1	1	1	

13-4. INDOOR UNIT HEAT EXCHANGER

19	E02 408 620	INDOOR HEAT EXCHANGER		1	1		
	E02 515 620	INDOOR HEAT EXCHANGER				1	
20	E02 151 667	UNION(LIQUID)		1	1	1	φ6.35
21	E02 151 666	UNION(GAS)		1	1		φ9.52
	E02 155 666	UNION(GAS)				1	φ12.7

13-5. OUTDOOR UNIT STRUCTURAL PARTS

MU-C07TV -E1

MU-C09TV -E1

MU-C12TV -E1

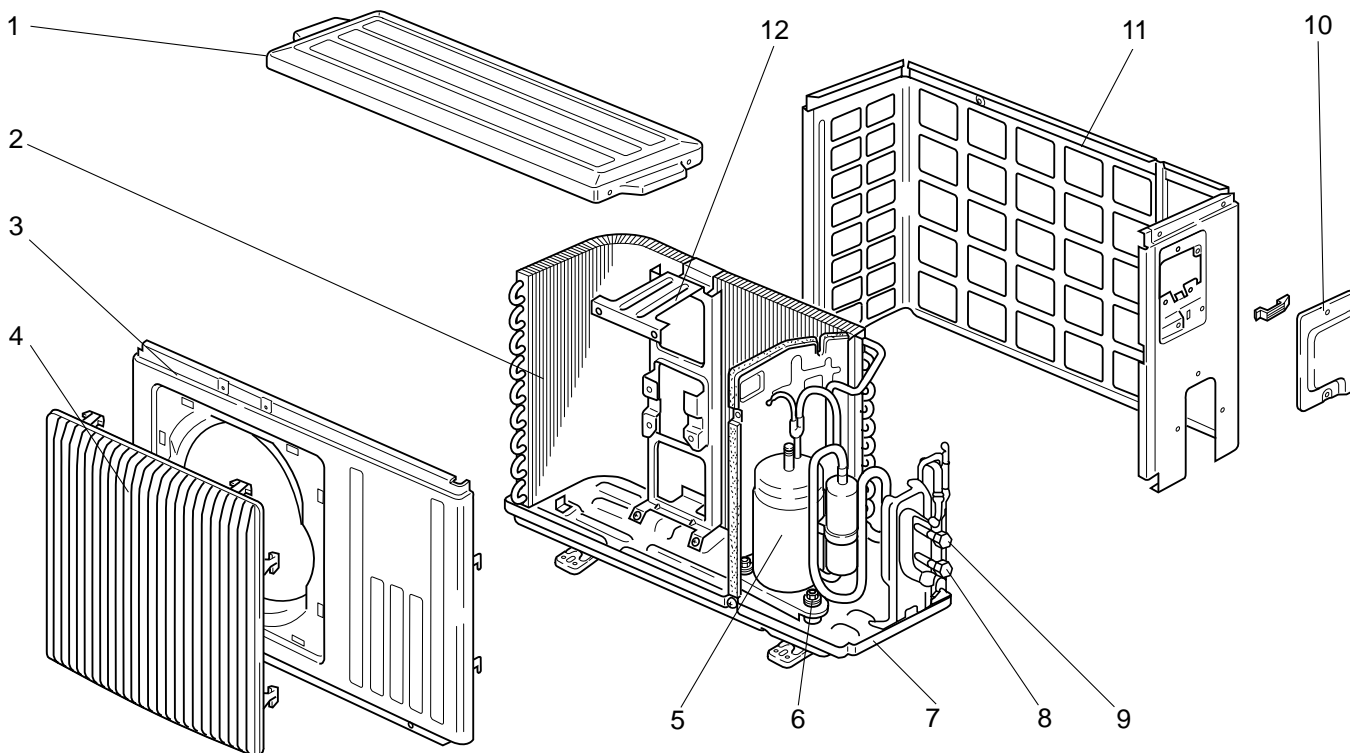

Part number that is circled is not shown in the illustration.

No.	Part No.	Part name	Symbol in Wiring Diagram	Q'ty/unit			Remarks
				MU-C07TV-E1	MU-C09TV-E1	MU-C12TV-E1	
1	E02 336 297	TOP PANEL		1	1	1	
2	E02 336 630	OUTDOOR HEAT EXCHANGER		1	1	1	
3	E02 336 232	CABINET		1	1	1	
4	E02 336 521	GRILLE		1	1	1	
5	E02 621 900	COMPRESSOR	MC	1			RE-130VGSHT
	E02 622 900	COMPRESSOR	MC		1		RE-145VGSHT
	E02 515 900	COMPRESSOR	MC			1	RE-231VHSHT
6	E02 336 506	COMPRESSOR RUBBER SET		3	3		3RUBBERS/SET
	E02 075 506	COMPRESSOR RUBBER SET				3	3RUBBERS/SET
7	E02 339 290	BASE		1	1		
	E02 340 290	BASE				1	
8	E02 621 661	STOP VALVE(GAS)		1	1		φ9.52
	E02 623 661	STOP VALVE(GAS)				1	φ12.7
9	E02 621 662	STOP VALVE(LIQUID)		1	1	1	φ6.35
10	E02 336 245	SERVICE PANEL		1	1	1	
11	E02 339 233	BACK PANEL		1	1		
	E02 440 233	BACK PANEL				1	
12	E02 336 515	MOTOR SUPPORT		1	1	1	
⑬	E02 339 936	CAPILLARY TUBE		1			φ3.0xφ1.4x600
	E02 023 936	CAPILLARY TUBE			1		φ3.0xφ1.4x750
	E02 412 936	CAPILLARY TUBE				1	φ3.0xφ1.6x600

MU-C07TV -E1

MU-C09TV -E1

MU-C12TV -E1

**13-6. OUTDOOR UNIT
FUNCTIONAL PARTS AND
ELECTRICAL PARTS**

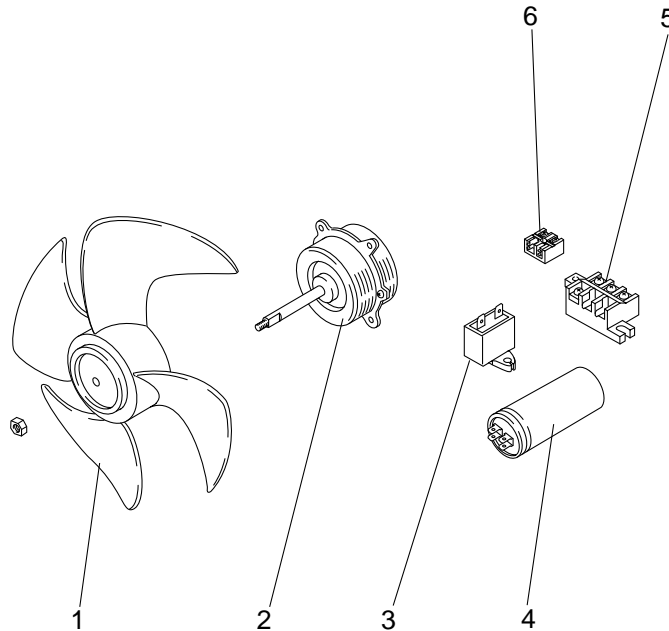

Part numbers that are circled are not shown in the illustration.

No.	Part No.	Part name	Symbol in Wiring Diagram	Q'ty/unit			Remarks
				MU-C07TV-E1	MU-C09TV-E1	MU-C12TV-E1	
1	E02 336 501	PROPELLER FAN		1	1	1	
2	E02 437 301	OUTDOOR FAN MOTOR	MF	1	1		RA6V23-□□
	E02 439 301	OUTDOOR FAN MOTOR	MF			1	RA6V33-□□
3	E02 095 350	OUTDOOR FAN CAPACITOR	C2	1	1	1	1.5 μ F /440VAC
4	E02 085 353	COMPRESSOR CAPACITOR	C1	1	1		25 μ F /440VAC
	E02 079 353	COMPRESSOR CAPACITOR	C1			1	30 μ F /440VAC
5	E02 466 375	TERMINAL BLOCK	TB1	1	1	1	3P
6	E02 438 374	TERMINAL BLOCK	TB2	1	1	1	2P
⑦	E02 466 340	CONTACTOR	52C	1	1	1	
⑧	E02 095 382	FUSE	F	1	1	1	250V/2A
⑨	E02 128 383	SURGE ABSORBER	DSAR	1	1	1	

13-7. OUTDOOR UNIT STRUCTURAL PARTS

MUH-C07TV -E1

MUH-C09TV -E1

MUH-C12TV -E1

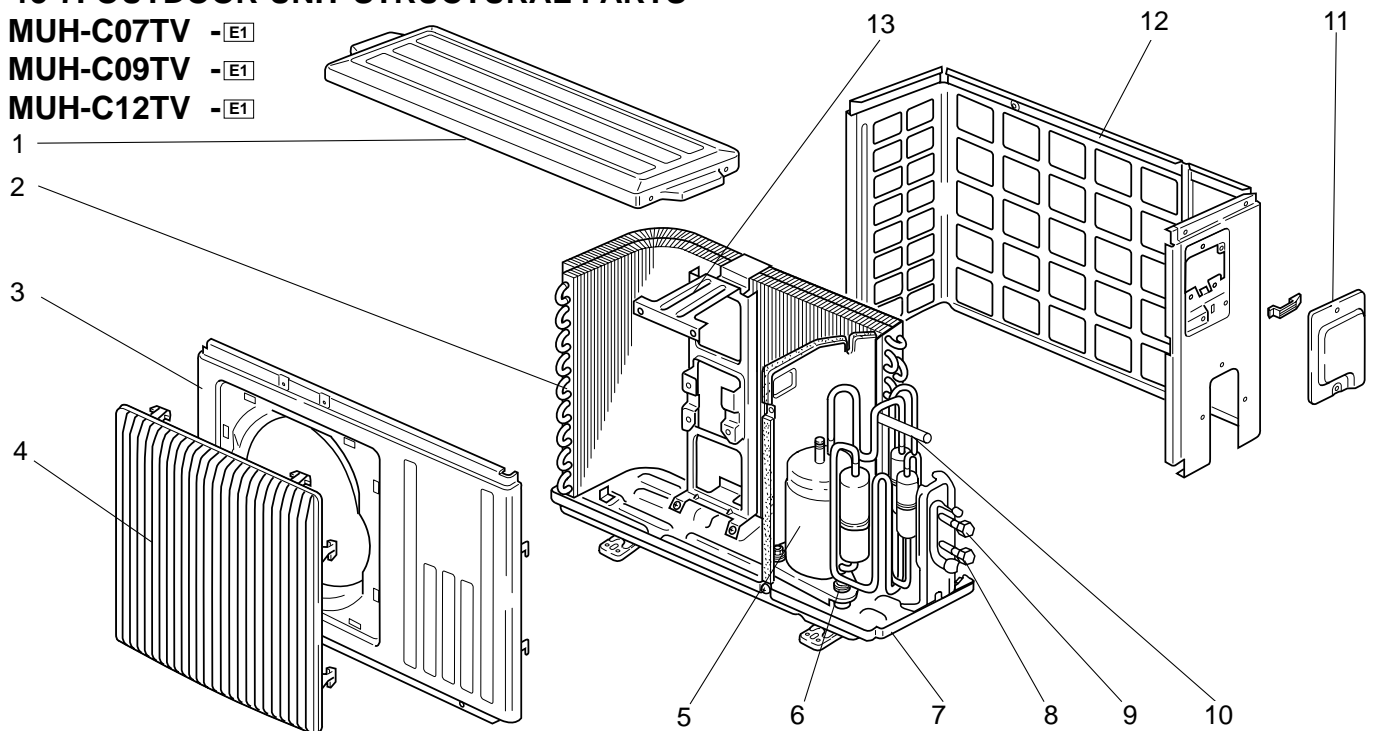

These figures show about MUH-C09/C12TV.

Part numbers that are circled are not shown in the illustration.

No.	Part No.	Part name	Symbol in Wiring Diagram	Q'ty/unit			Remarks
				MUH-C07TV-E1	MUH-C09TV-E1	MUH-C12TV-E1	
1	E02 336 297	TOP PANEL		1	1	1	
2	E02 440 630	OUTDOOR HEAT EXCHANGER		1			
	E02 628 630	OUTDOOR HEAT EXCHANGER			1	1	
3	E02 336 232	CABINET		1	1	1	
4	E02 336 521	GRILLE		1	1	1	
5	E02 513 900	COMPRESSOR	MC	1			RE-135VGSHT
	E02 514 900	COMPRESSOR	MC		1		RE-174VGSHT
	E02 515 900	COMPRESSOR	MC			1	RE-231VHSHT
6	E02 336 506	COMPRESSOR RUBBER SET		3	3		3RUBBERS/SET
	E02 075 506	COMPRESSOR RUBBER SET				3	3RUBBERS/SET
7	E02 339 290	BASE		1	1		
	E02 340 290	BASE				1	
8	E02 621 661	STOP VALVE(GAS)		1	1		φ9.52
	E02 623 661	STOP VALVE(GAS)				1	φ12.7
9	E02 627 662	STOP VALVE(LIQUID)		1	1	1	φ6.35
10	E02 444 961	4-WAY VALVE		1	1	1	
11	E02 336 245	SERVICE PANEL		1	1	1	
12	E02 440 233	BACK PANEL		1	1	1	
13	E02 336 515	MOTOR SUPPORT		1			
	E02 442 515	MOTOR SUPPORT			1	1	
⑭	E02 159 936	CAPILLARY TUBE		2			φ3.0xφ1.4x800
	E02 156 936	CAPILLARY TUBE			2	2	φ3.0xφ1.4x500
	E02 139 936	CAPILLARY TUBE		1			φ3.0xφ1.6x750
	E02 627 936	CAPILLARY TUBE			1	1	φ3.0xφ1.8x400
	E02 408 936	CAPILLARY TUBE		1			φ3.0xφ1.4x700
	E02 172 937	CAPILLARY TUBE			1		φ3.0xφ1.4x650
	E02 515 937	CAPILLARY TUBE				1	φ3.0xφ1.6x800
⑮	E02 154 642	CHECK VALVE		1	1	1	

MUH-C07TV -E1

MUH-C09TV -E1

MUH-C12TV -E1

13-8. OUTDOOR UNIT FUNCTIONAL PARTS AND ELECTRICAL PARTS

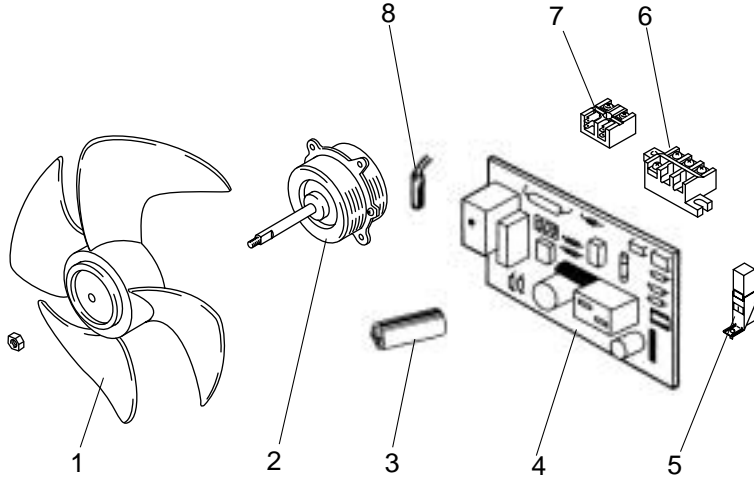

13-9. ACCESSORY PARTS

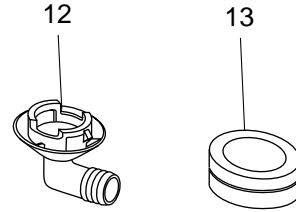

13-8. OUTDOOR UNIT FUNCTIONAL PARTS AND ELECTRICAL PARTS

Part numbers that are circled are not shown in the illustration.

No.	Part No.	Part name	Symbol in Wiring Diagram	Q'ty/unit			Remarks
				MUH-C07TV-E1	MUH-C09TV-E1	MUH-C12TV-E1	
1	E02 336 501	PROPELLER FAN		1	1	1	
2	E02 440 301	OUTDOOR FAN MOTOR	MF	1			RA6V23-□□
	E02 442 301	OUTDOOR FAN MOTOR	MF		1	1	RA6V33-□□
3	E02 085 353	COMPRESSOR CAPACITOR	C1	1	1		25 μ F /440VAC
	E02 079 353	COMPRESSOR CAPACITOR	C1			1	30 μ F /440VAC
4	E02 626 451	DEICER P.C. BOARD		1			
	E02 627 451	DEICER P.C. BOARD			1		
	E02 628 451	DEICER P.C. BOARD				1	
5	E02 128 383	SURGE ABSORBER	DSAR	1	1	1	
6	E02 466 375	TERMINAL BLOCK	TB1	1	1	1	3P
7	E02 440 374	TERMINAL BLOCK	TB2	1	1	1	2P
8	E02 289 310	DEFROST THERMISTOR	RT61	1			
	E02 440 310	DEFROST THERMISTOR	RT61		1	1	
⑨	E02 440 490	R.V. COIL	21S4	1	1	1	
⑩	E02 095 382	FUSE	F61	1	1	1	250V 2A
⑪	E02 336 385	VARISTOR	NR61	1	1	1	

13-9. ACCESSORY PARTS

12	E02 444 704	DRAIN SOCKET		1	1	1	
13	E02 440 705	DRAIN CAP		2	2	2	2PCS/SET

13-10. AIR CLEANING FILTER

- AIR CLEANING FILTER removes fine dust of 0.01 micron from air by means of static electricity.
- Normal life of AIR CLEANING FILTER is 4 months. However, when it becomes dirty, replace it as soon as possible.
- Clogged AIR CLEANING FILTER may reduce the air conditioner capacity or cause frost on the air outlet.
- DO NOT reuse AIR CLEANING FILTER even if it is washed.
- DO NOT remove or attach AIR CLEANING FILTER during unit operation.

Model	Part No.
MSC-C07TV- E1	MAC-1300FT
MSC-C09TV- E1	
MSC-C12TV- E1	

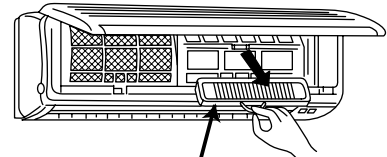

Air cleaning filter (White bellow type)

13-11. DEODORIZING FILTER

- DEODORIZING FILTER removes ammonia and hydrogen sulphide emitted from tobacco, and odor of pets.
- Clean DEODORIZING FILTER every two weeks. If the filter is particularly dirty, clean the filter more often.
- For cleaning, soak the filter in warm water for a while, and then wash and rinse it. Dry the filter in the shade thoroughly.
- When the filter color is still dark even after cleaning, replace the filter with a new one.
Replace the filter at least once a year.

Model	Part No.
MSC-C07TV- E1	MAC-1800DF
MSC-C09TV- E1	
MSC-C12TV- E1	

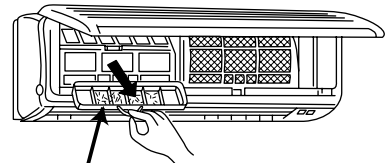

Deodorizing filter (Gray sponge type)

- DEODORIZING FILTER and AIR CLEANING FILTER can be attached on either side.



© Copyright 2000 MITSUBISHI ELECTRIC ENGINEERING CO.,LTD.
Issued in Dec. 2000. No.OB269 223
Made in Japan

New publication, effective Dec. 2000
Specifications subject to change without notice.