

Revision B:

- MUFZ-KJ25VE -ER1, MUFZ-KJ35VE -ER1 and MUFZ-KJ50VE -ER1 have been added.

Please void OBH667 REVISED EDITION-A.

OUTDOOR UNIT PARTS CATALOG

No. OBB667
REVISED EDITION-B

Models

MUFZ-KJ25VE -E1, ER1

MUFZ-KJ35VE -E1, ER1

MUFZ-KJ50VE -E1, ER1

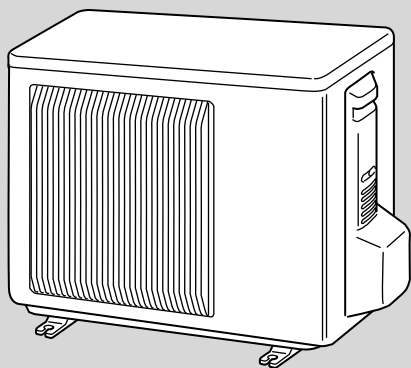

MUFZ-KJ25VE
MUFZ-KJ35VE

CONTENTS

1. RoHS PARTS LIST..... 2

SERVICE MANUAL (OBH667)

NOTE:

RoHS compliant products have <G> mark on the spec name plate.



Revision A:

- MUFZ-KJ50VE- [E1] has been added.

Revision B:

- MUFZ-KJ25VE -[ER1], MUFZ-KJ35VE -[ER1] and MUFZ-KJ50VE -[ER1] have been added.

1 RoHS PARTS LIST

MUFZ-KJ25VE MUFZ-KJ35VE

1-1. OUTDOOR UNIT STRUCTURAL PARTS AND FUNCTIONAL PARTS

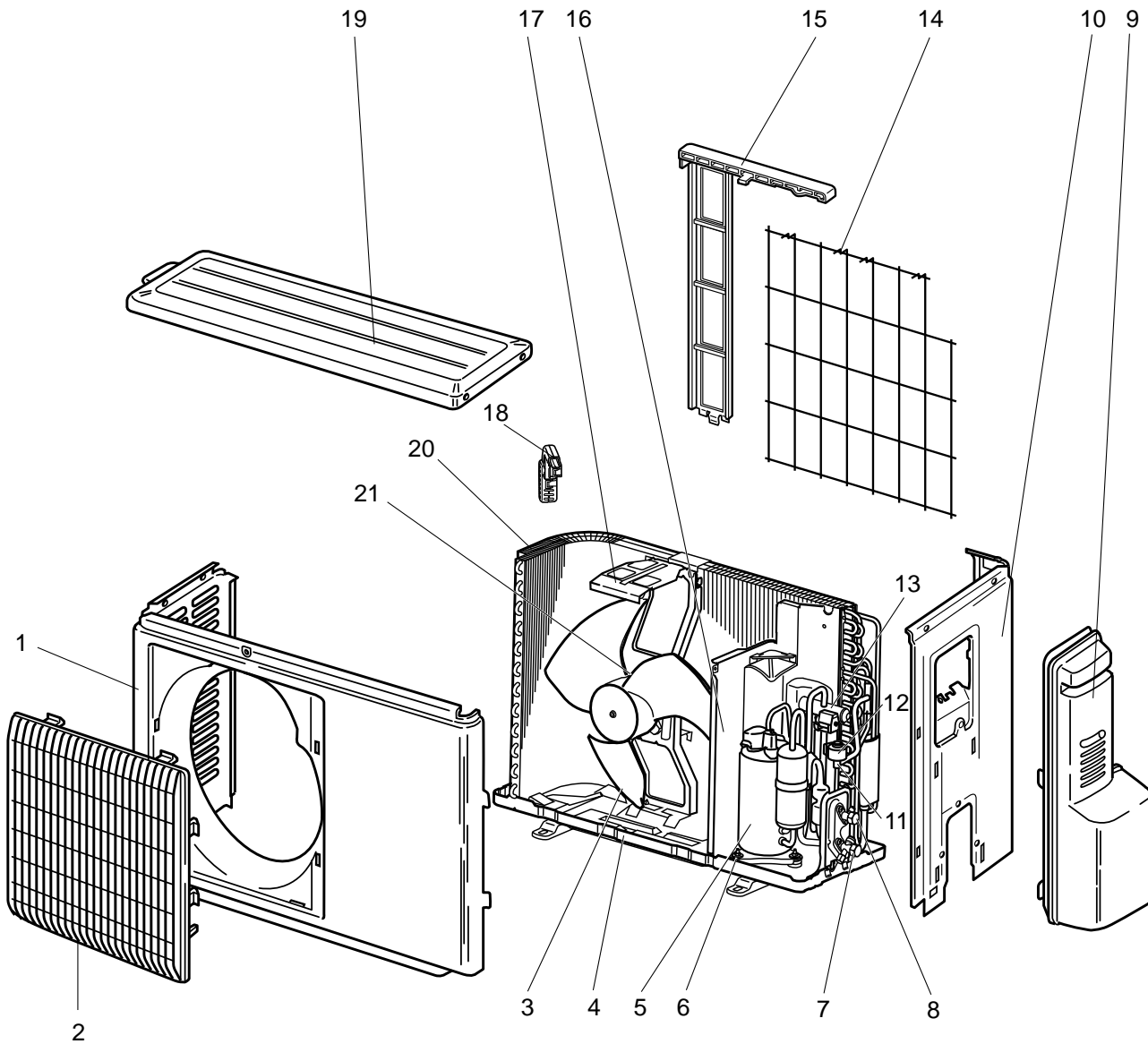

RoHS PARTS LIST

1-1. OUTDOOR UNIT STRUCTURAL PARTS AND FUNCTIONAL PARTS

Part numbers that are circled are not shown in the illustration.

No.	RoHS	Part No.	Part Name	Symbol in Wiring Diagram	Q'ty/unit				Remarks
					MUFZ-KJ25VE-		MUFZ-KJ35VE-		
					E1	ER1	E1	ER1	
1	G	E12 927 232	CABINET		1	1	1	1	
2	G	E12 927 521	GRILLE		1	1	1	1	
3	G	E12 927 501	PROPELLER		1	1	1	1	
4	G	E12 D69 290	BASE		1	1	1	1	
5	G	E12 J47 900	COMPRESSOR	MC	1	1	1	1	SNB140FRUMT
6	G	E12 C34 506	COMPRESSOR RUBBER SET		3	3	3	3	3 RUBBERS/SET
7	G	E12 927 661	STOP VALVE (GAS)		1	1	1	1	ø9.52
8	G	E12 927 662	STOP VALVE (LIQUID)		1	1	1	1	ø6.35
9	G	E12 927 245	SERVICE PANEL		1	1	1	1	
10	G	E12 C37 233	BACK PANEL		1	1	1	1	
11	G	E12 838 640	EXPANSION VALVE		1	1	1	1	
12	G	E12 G10 493	EXPANSION VALVE COIL	LEV	1	1	1	1	
13	G	E12 J44 961	4-WAY VALVE		1	1	1	1	
14	G	E12 930 525	CONDENSER WIRE NET		1	1	1	1	
15	G	E12 930 523	CONDENSER NET		1	1	1	1	
16	G	E12 G11 293	SEPARATOR		1	1	1	1	
17	G	E12 929 515	MOTOR SUPPORT		1	1	1	1	
18	G	E12 D84 079	THERMO HOLDER		1	1	1	1	
19	G	E12 927 297	TOP PANEL		1	1	1	1	
20	G	E12 J47 630	OUTDOOR HEAT EXCHANGER		1	1	1	1	
21	G	E12 A47 301	OUTDOOR FAN MOTOR	MF	1	1	1	1	RC0J50-□□
22	G	E12 J47 936	CAPILLARY TUBE		1	1	1	1	ø4.0×ø2.4×240
23	G	E12 F35 936	CAPILLARY TUBE		4	4	4	4	ø3.0×ø2.0×210
24	G	E12 838 704	DRAIN SOCKET		1	1	1	1	

RoHS PARTS LIST

MUFZ-KJ25VE MUFZ-KJ35VE 1-2. OUTDOOR UNIT ELECTRICAL PARTS

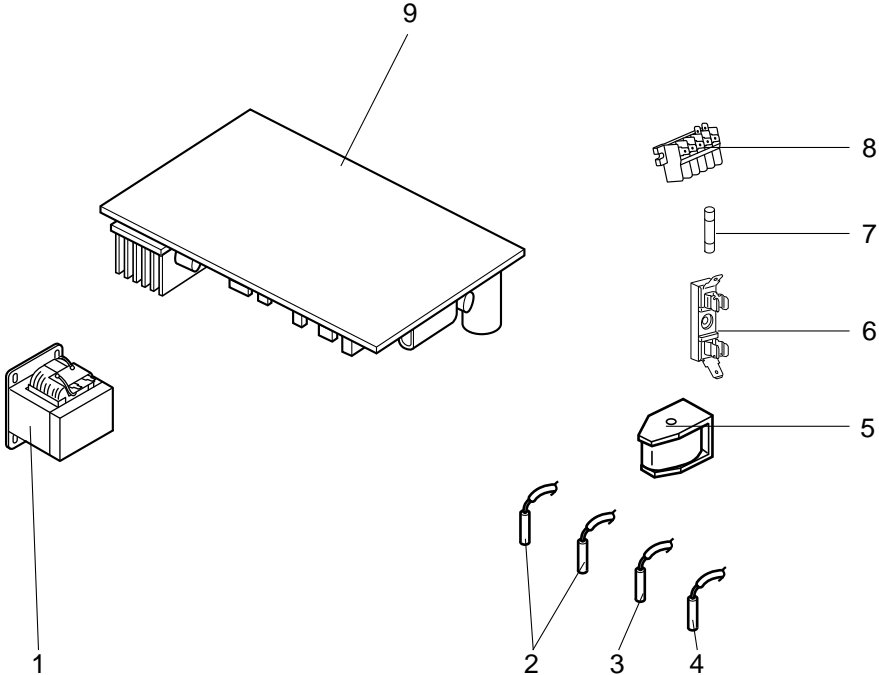

RoHS PARTS LIST

1-2. OUTDOOR UNIT ELECTRICAL PARTS

No.	RoHS	Part No.	Part Name	Symbol in Wiring Diagram	Q'ty/unit				Remarks
					MUFZ-KJ25VE-		MUFZ-KJ35VE-		
					E1	ER1	E1	ER1	
1	G	E12 G11 337	REACTOR	L61	1	1	1	1	
2	G	E12 C34 306	THERMISTOR SET	RT61, RT62	1	1	1	1	DEFROST, DISCHARGE
3	G	E12 D65 308	AMBIENT TEMPERATURE THERMISTOR	RT65	1	1	1	1	
4	G	E12 C34 307	OUTDOOR HEAT EXCHANGER TEMPERATURE THERMISTOR	RT68	1	1	1	1	
5	G	E12 J47 490	R.V. COIL	21S4	1	1	1	1	
6	G	E12 735 241	FUSE HOLDER		1	1	1	1	
7	G	E12 735 382	FUSE	F61	1	1	1	1	T20AL250V
8	G	E12 G16 374	TERMINAL BLOCK	TB	1	1	1	1	5 P
9	G	E12 L39 451	INVERTER P.C. BOARD		1	1			Including heat sink and RT64
	G	E12 L40 451					1	1	

RoHS PARTS LIST

MUFZ-KJ50VE

1-3. OUTDOOR UNIT STRUCTURAL PARTS, ELECTRICAL PARTS AND FUNCTIONAL PARTS

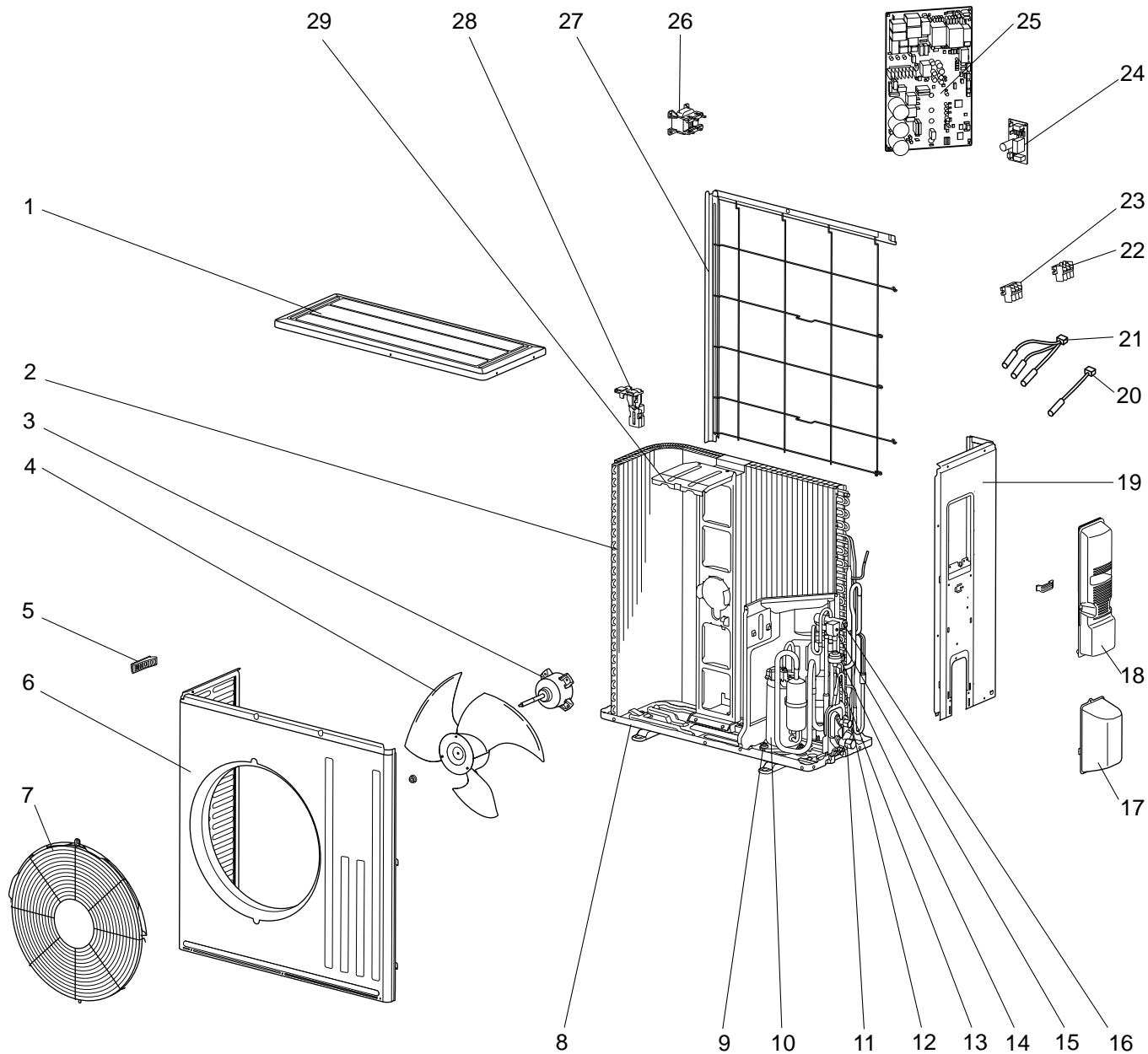

1-3. OUTDOOR UNIT STRUCTURAL PARTS, ELECTRICAL PARTS AND FUNCTIONAL PARTS

Part numbers that are circled are not shown in the illustration.

No.	RoHS	Part No.	Part Name	Symbol in Wiring Diagram	Q'ty/unit		Remarks
					MUFZ-KJ50VE-		
					E1	ER1	
1	G	E12 F28 297	TOP PANEL		1	1	
2	G	E12 J49 630	OUTDOOR HEAT EXCHANGER		1	1	
3	G	E12 F28 301	OUTDOOR FAN MOTOR	MF	1	1	RC0J60-□□
4	G	E12 F28 501	PROPELLER		1	1	
5	G	E12 817 009	HANDLE		1	1	
6	G	E12 F28 232	CABINET		1	1	
7	G	E12 F73 521	FAN GUARD		1	1	Including ice guard
8	G	E12 F28 290	BASE		1	1	
9	G	E12 C34 506	COMPRESSOR RUBBER SET		3	3	3 RUBBERS/SET
10	G	E12 J40 900	COMPRESSOR	MC	1	1	SNB172FEKMT
11	G	E12 G16 661	STOP VALVE (GAS)		1	1	∅12.7
12	G	E12 G16 662	STOP VALVE (LIQUID)		1	1	∅6.35
13	G	E12 851 640	EXPANSION VALVE		1	1	
14	G	E12 F28 493	EXPANSION VALVE COIL	LEV	1	1	
15	G	E12 J61 490	R.V. COIL	21S4	1	1	
16	G	E12 J61 961	4-WAY VALVE		1	1	
17	G	E12 F28 650	VALVE COVER		1	1	
18	G	E12 J61 245	SERVICE PANEL		1	1	
19	G	E12 J52 233	BACK PANEL (OUT)		1	1	
20	G	E12 J61 309	AMBIENT TEMPERATURE THERMISTOR	RT65	1	1	
21	G	E12 F28 308	THERMISTOR SET	RT61,RT62, RT68	1	1	DEFROST, DISCHARGE, OUTDOOR HEAT EXCHANGER TEMPERATURE
22	G	E12 F29 374	TERMINAL BLOCK	TB1	1	1	3 P
23	G	E12 J61 374	TERMINAL BLOCK	TB2	1	1	3 P
24	G	E12 J61 445	RELAY P.C. BOARD		1	1	
25	G	E12 L43 451	INVERTER P.C. BOARD		1	1	Including heat sink and RT64
26	G	E12 F28 337	REACTOR	L	1	1	
27	G	E12 F28 523	CONDENSER NET		1	1	
28	G	E12 F28 079	THERMO HOLDER		1	1	
29	G	E12 F28 515	MOTOR SUPPORT		1	1	
③⑩	G	E12 527 936	CAPILLARY TUBE		1	1	∅4.0 × ∅2.4 × 100
③⑪	G	E12 F28 704	DRAIN SOCKET		1	1	

mitsubishi electric corporation
HEAD OFFICE: TOKYO BLDG., 2-7-3, MARUNOUCHI, CHIYODA-KU, TOKYO 100-8310, JAPAN

© Copyright 2013 MITSUBISHI ELECTRIC CORPORATION
Distributed in Jan. 2014. No. OBB667 REVISED EDITION-B
Distributed in Oct. 2013. No. OBB667 REVISED EDITION-A
Distributed in Jun. 2013. No. OBB667
Made in Japan

New publication, effective Jan. 2014
Specifications are subject to change without notice.