

TYPE	CEILING RECESSED LOSSNAY	VOLUME	
MODEL	LGH-50RSDC-E	SIGN	

Heat exchange system	Air-to-air total heat exchange(sensible heat + latent heat exchange)											
Heat exchange element material	Partition-spacing plate-special treated paper											
Cladding	Galvanized steel sheet											
Heat insulating material	Self-extinguishing urethane foam											
Motor	DC Brushless motor 2unit											
Blower	220mm dia. Centrifugal fan											
Filter material	Non-woven fabrics filter(Gravitational method 82%, EU-G3)											
Applicable air condition of setting environment	The setting air condition shall be between -10°C to 40°C, 80%RH or less.											
Applicable air condition range of outdoor and indoor	OA temperature shall be -15°C to +40°C, 80%RH, or less, with general air conditioning room environment.											
Functions	Lossnay ventilation 5speed / Bypass ventilation(5speed + power)											
Weight	48kg											
Frequency/ Power source	50Hz/Single phase 220-240V											
Ventilation mode	Lossnay ventilation					Bypass ventilation						
Fan speed (230V)	1	2	3	4	5	Power	1	2	3	4	5	
Current (A)	1.17	0.67	0.35	0.20	0.13	1.80	1.20	0.70	0.35	0.20	0.13	
Power consumption (W)	165	90	41	22	14	265	164	90	40	21	14	
Air volume	(m ³ /h)	395	305	215	144	90	468	395	305	215	144	90
	(L/s)	110	85	60	40	25	130	110	85	60	40	25
External static pressure	(mmH ₂ O)	10.2	6.1	3.1	1.5	0.7	13.8	10.2	6.1	3.1	1.5	0.7
	(Pa)	100	60	30	15	7	135	100	60	30	15	7
Temperature exchange efficiency (%)		77.5	81.5	85.5	88	90	-	-	-	-	-	-
Enthalpy exchange efficiency (%)	Heating	71	75	79	82	84	-	-	-	-	-	-
	Cooling	68	72.5	77	80.5	83	-	-	-	-	-	-
Noise (dB)	Measured at 1.5m under the center of panel in an anechoic chamber	31	26.5	21	18	18	35	31	26.5	21	18	18
Starting current	Under 2.5A less											
Insulation resistance	10MΩ or more (500V megger)											
Dielectric strength	AC 1500V 1 minute											

Characteristic curve

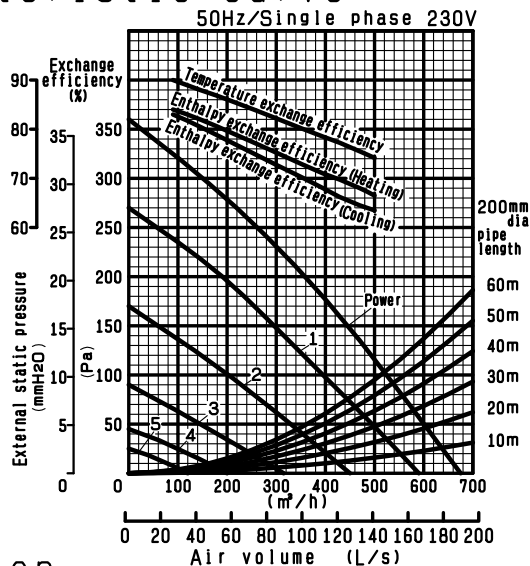

* This specifications are under 230V/50Hz
 * Exchange efficiency test condition is following.
 Winter heating condition (EN308) OA:5°CDB 2.5°CWB, RA:25°CDB 14°CWB
 Summer cooling condition (JIS B 8628) OA:34.5°CDB 30.5°CWB, RA:26.5°CDB 21.5°CWB

* Attention

- Cold operation mode(*1) is to start repeating in the case that Lossnay's detected OA temperature is less than -10°C.
 *1. Supply air(SA) in the operation for 60min. followed by stop operation for 10min.
- The current, power consumption and efficiency are based on the above air flow rate.
- Fan speed is selectable by the contacts(customer preparation) from 1, 2, 3, 4, 5, PB(Power By-pass).
- Lossnay ventilation mode is to start automatically in the case that Lossnay's detected OA temperature is less than +8°C, even if Bypass ventilation is set by remote controller.
- The Air outlets noise(45° angle, 1.5meters in front of the unit) is about 4dB greater than the indicated value.
- Temperature Exchange efficiency(%) are based on winter condition. (at 1 fan speed)
- Mitsubishi Electric measures the machine according to the Japan Industrial Standards (JIS B 8628).

*2. Specifications may be subject to change without notice.

SPECIFICATIONS	DATE	TYPE	CEILING RECESSED LOSSNAY	
	27-May.-09	MODEL	LGH-50RSDC-E (50Hz)	
		NUMBER	ND109000	1/5

Outline drawings

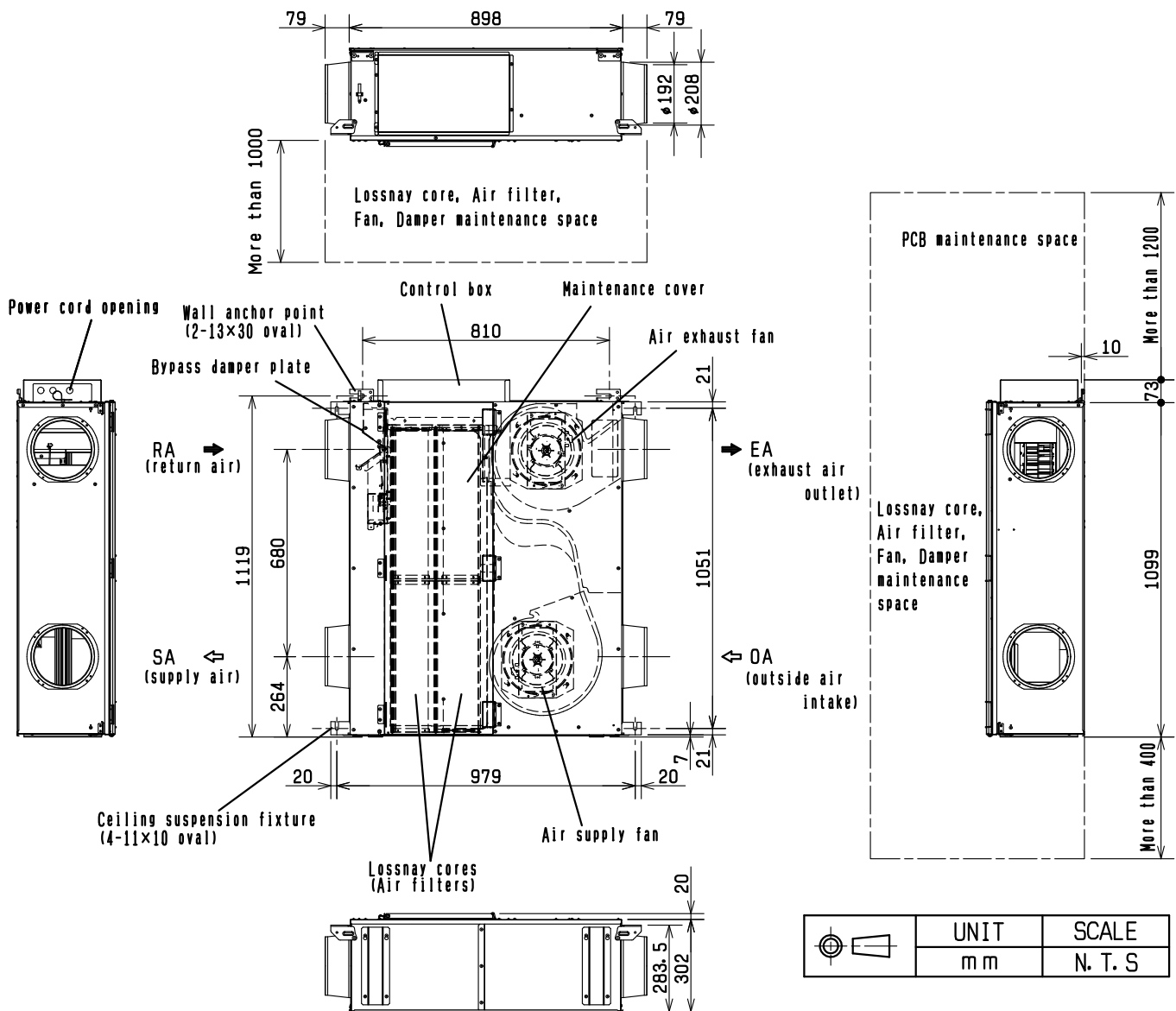

Attention

- When using the product where it is exposed to high temperatures and humidity (40C or higher, RH 80% or higher), or where fog occurs frequently, moisture is likely to condense in the core, and may result in condensation build up in the unit. The product should not be used under such conditions.
- Outdoor air may enter the Lossnay owing to the pressure difference between indoor and outdoor or external winds even when the product is not operated. It is recommended to install an Electrically operated damper to block the outdoor air.
- In a cold weather area, an area with strong external winds or where fog occurs frequently, cold outdoor air, external winds or fog may be introduced into the product when its operation is stopped. It is recommended to install an Electrically operated damper.
- When using the product in an environment where there is a window, or opening near the outdoor louvre, where insects are likely to gather around the interior or exterior light, take note that small insects may intrude into the product.
- In a cold weather area, or others, dewing or freezing could occur on the main unit, where the duct is connected, or other sections, depending on the conditions of outdoor air and indoor temperature and moisture, even if they are within the range of operating conditions. Make sure to confirm the operating conditions and other precautions, and do not use the product if dewing or freezing is anticipated.
- The outside ducts must be tilted at a gradient (1/30 or more) down toward the outdoor louver from Lossnay, and properly insulated.
(The entry of rain water may cause power leakage, fire, or damage to household property)
- The all ducts must be covered with heat-insulating material in order to prevent condensation from forming.
- The space for cleaning filters or maintenance parts should be provided as outline drawing.

*Specifications may be subject to change without notice.

OUTLINE DRAWINGS	DATE	TYPE MODEL	CEILING RECESSED LOSSNAY	
	27-May.-09		LGH-50RSDC-E (50HZ)	
MITSUBISHI ELECTRIC CORPORATION		NUMBER	ND109000	2/5

Outline drawings

- NOTE
1. Connect the wires show as dotted lines.
 2. Be sure to connect the ground wire.
 3. A power supply isolator must be installed when wiring power supply to unit.
 4. Always use a single pole isolator for the main switch power connection.
 5. If using earth leakage breaker for isolator, rating of sensed current should be more than 10mA.
 6. All supply circuits must be disconnected, and do not touch the components for more than 5 minutes, before obtaining access to terminal devices.

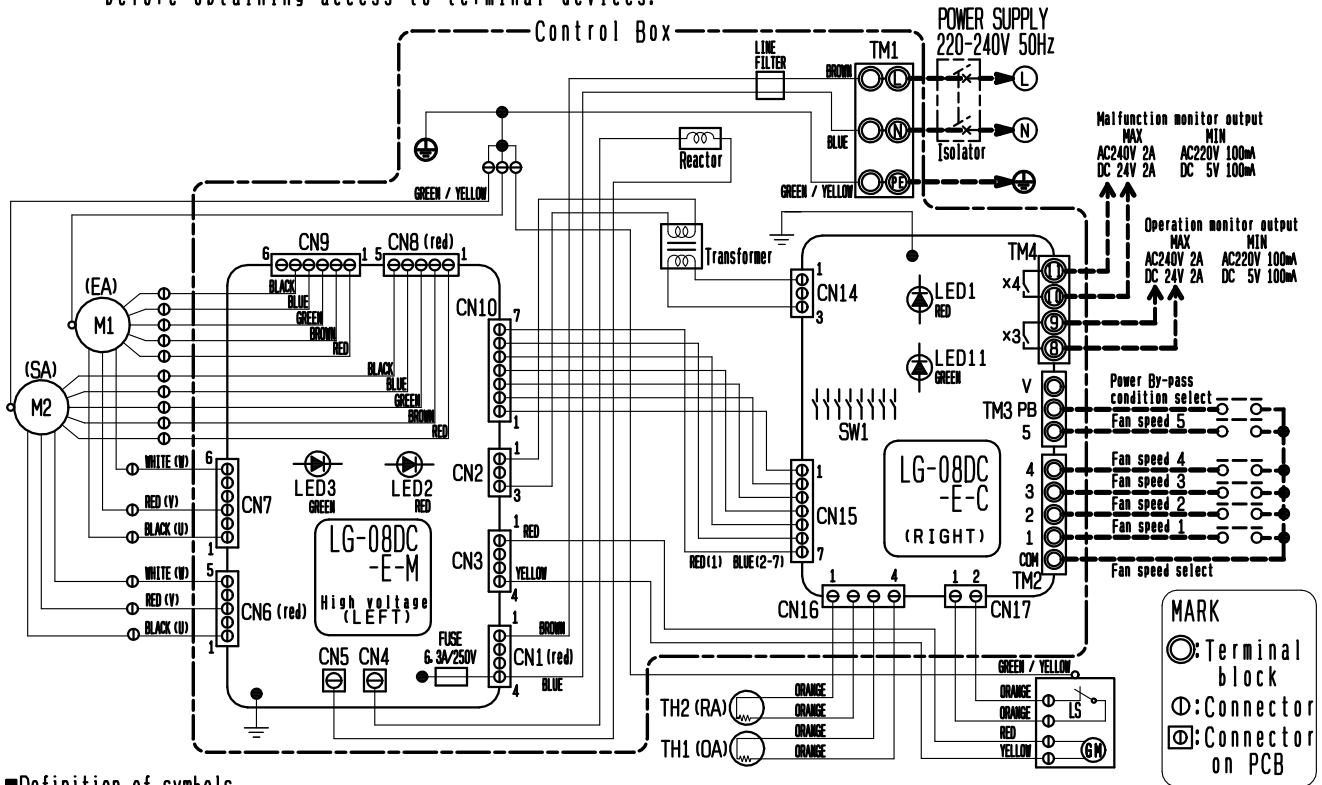

Definition of symbols

- | | | |
|---|---|--|
| M1 :Motor for exhaust fan | LED1 (red):Power supply indicator lamp | CN6:Connector (Supply fan motor) |
| M2 :Motor for supply fan | LED2 (red):Inspection indicator lamp | CN7:Connector (Exhaust fan motor) |
| GM :Motor for Bypass damper | LED3 (green):Inspection indicator lamp | CN8:Connector (Signal for supply fan motor) |
| LS :Micro switch | LED11 (green):Inspection indicator and trial operation lamp | CN9:Connector (Signal for exhaust fan motor) |
| TH1:Thermistor for outside air | CN1:Connector (Power supply) | CN10:Connector (Signal line) |
| TH2:Thermistor for return air | CN2:Connector (Transformer primary) | CN14:Connector (Transformer secondary) |
| TM1:Terminal block (Power supply) | CN3:Connector (Motor for By-pass damper) | CN15:Connector (Signal line) |
| TM2:Terminal block (Fan speed selection) | CN4:Connector (Reactor) | CN16:Connector (Thermistor) |
| TM3:Terminal block (By-pass mode selection) | CN5:Connector (Reactor) | CN17:Connector (Micro switch) |
| TM4:Terminal block (Monitor output) | | |

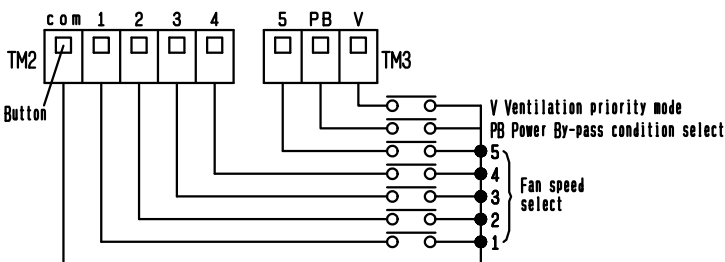

- contact :12VDC 10mA
 cable for operation:0.5mm²to 1.0mm²
 maximum length :20m from terminal block
 peeling wire length:9~10mm
- Do not connect multiple wires on the one terminal.
 - Always separate the power supply cable and the cable to the control unit by 10 cm or more to prevent malfunctioning of the unit.
 - If the length of the stripped power cables wires is too long, the conductors may touch and cause shorting.
 - Power supply cable size:1.5mm² or more

Caution

- Power BY-pass mode is not available even if only PB contact is on. When turning on Power By-pass contact with any fan speed contacts on, unit operation becomes Power By-pass mode.
- Be sure to connect Fan speed 5 wiring. Set 5 fanspeed for 24hours ventilation.
- Fan operating may be delayed from the time of contact ON depending on the select timing.
- By-pass damper is automatically operated based on the OA and RA temperature.

*Specifications may be subject to change without notice.

WIRING DIAGRAM	DATE	TYPE MODEL	CEILING RECESSED LOSSNAY	
	27-May.-09		LGH-50RSDC-E (50Hz)	
MITSUBISHI ELECTRIC CORPORATION		NUMBER	ND109000	3/5

Lossnay model selection advices

1. Operating environment

Install this product in an environment where the temperature ranges from -10°C to +40°C and the relative humidity is less than 80%RH. If condensation is expected to form, heat up the fresh outside air should be treated.

2. Do not use under high temperature and humidity condition

Condensation will occur and water will gather inside the Lossnay cores under high temperature and humidity condition, such as warm swimming pool, bathroom, greenhouse or foggy place.

3. Condition of outdoor, indoor and return air

Avoid using Lossnay under air condition with acid, alkalis, organic solvent, oil mist, paint, or harmful gas as pesticide, corrosive gas, etc.

4. Insulation failure caused by salt or sulphur air and hot spring steam, Rust, fire or malfunction may occur.

Installing high quality filters inside outdoor air duct if the Lossnay operates in salt or sulphur air conditions.

5. Intake of mist or outdoor air during off-mode operation

Outdoor air or mist may flow through the duct into your room when Lossnay is in off-mode at windy and foggy area. To prevent intake of outdoor air or fog, a damper is advised to be installed.

6. Entry of insects

When using the product in an environment where there is a window, or opening near the outdoor hood, so that insects are likely to gather around the interior or exterior light, take note that small insects may intrude into the Lossnay filters.

7. By-pass ventilation

In the case of "By-pass" ventilation, the supply air temperature slightly rises more than the outside air temperature because of the effect around the ducts or the unit motors.

Caution for installation

1. Do not modify the unit as it may cause malfunction.

2. Leaving sufficient space for maintenance purpose.

3. Set 5 fanspeed for 24hours ventilation.

In the case of 24hours ventilation with vertical installation, take measures for water leakage from bottom of the unit with using drain pan as like when accidentally intaking dense fog for long hours during over 4 fanspeed operation. If the unit continues to intake dense fog, accumulated water by fog may be leak from the bottom of the unit.

4. The location of the air inlet

Take care in locating air inlet to prevent intake of dirty air or disgusting smell from exhaust gas of factory, air from rubbish disposal, etc.

5. Take precautions when using the product in a quiet location.

6. Heat insulation foam for duct

Take care as below to prevent the contaminate ceiling by duct condensation.

①All ducts must be covered with heat-insulating material in order to prevent condensation.

②Outdoor air may come into unit during not operating unit by the pressure difference between indoor and outdoor or the outdoor wind. In this case you should install a damper.

③It is possible for condensation and freezing to occur in the cold regions inside the unit because of the outdoor air condition or humidity condition above ceiling. Make sure to install supplemental insulation foam.

④In the case that air condition around Lossnay unit is high temperature in summer, it is recommended that there are heat insulation foam on indoor side duct to prevent heat recovery decreased by warming indoor duct. In winter, it is possible to cool indoor side duct without heat insulation foam on indoor side duct.

※Specifications may be subject to change without notice.

SAFTY NOTES	DATE	TYPE MODEL	CEILING RECESSED LOSSNAY	
	27-May. -09		LGH-50RSDC-E (50Hz)	
 MITSUBISHI ELECTRIC CORPORATION		NUMBER	ND109000	4/5

6. Prevent entry of rainwater into Lossnay unit

Install weather louvre or 'Weather cover' for OA inlet & EA outlet.

This is to prevent rainwater entering the Lossnay unit.

Ducts to outdoor(OA and EA) should decline by 1/30 or more.

- ① Install the anchor bolts to ensure the product's weight or earthquake load. (Correctly rated wire/chain may also be used)
- ② Do not install this product in a place where it is exposed to ultraviolet light. (UV may be damage covering insulation.)

7. Electrical Work

A single pole isolator must be installed at the origins of mains power supply.

Use single flush box, to support remote controller.

Must connect ground wiring.

When connecting external devices (electrically operated damper, lamp, monitoring unit, etc.) using output signals of the lossnay unit, make sure to install safety equipment for the external devices.

(It could cause fire, damage, etc. without safety equipment)

Maintenance

Refer to each model's operation instructions for the suggested maintenance period and methods.

General indication of lifetime of the main parts is as below.

Time below is unrelated to guaranteed period for service. And parts exchange period varies with usage condition.

Lossnay cores	: around 10 years with maintenance as stated periods.
Air Filters	: around 5 years with maintenance as stated periods
High efficiency filters	: 3000 hours (Optional Parts)
Motor	: 30000 hours

※Specifications may be subject to change without notice.

SAFTY NOTES	DATE	TYPE MODEL	CEILING RECESSED LOSSNAY LGH-50RSDC-E (50Hz)
	27-May.-09		
 MITSUBISHI ELECTRIC CORPORATION	NUMBER	ND109000	5/5