



# PURY-RP300YJM-B

Replace Multi R2 Series 12hp Outdoor Unit

R410A Heat Recovery

The latest VRF Replace Multi from Mitsubishi Electric is specifically designed for the maturing refurbishment sector, enabling the reuse of existing R22/R407c pipework, whilst also allowing the upgrade to some of the most efficient systems available in the market.

- **Tried and tested technology that's been employed for over 5 years**
- **Efficient use of existing resources - refrigerant piping, control and power wiring and less waste materials**
- **Reduced installation time with minimised disruption**
- **Ability to replace many non Mitsubishi Electric systems**



Pictures not to scale



## Product Details

| PURY-RP300YJM-B                     |                |
|-------------------------------------|----------------|
| Capacity (kW):                      |                |
| Heating (Nominal)                   | 37.5           |
| Cooling (Nominal)                   | 33.5           |
| Heating (UK)                        | 36.0           |
| Cooling (UK)                        | 31.5           |
| Power Input (kW) Heating (Nominal)  | 8.7            |
| Power Input (kW) Cooling (Nominal)  | 8.35           |
| Power Input (kW) Heating (UK)       | 11.48          |
| Power Input (kW) Cooling (UK)       | 6.1            |
| Max No. of Connectable Indoor Units | 30             |
| Airflow(m <sup>3</sup> /min)        | 225            |
| Noise (dBA)                         | 59             |
| Width - mm                          | 1220           |
| Depth - mm                          | 760            |
| Height - mm                         | 1710           |
| Weight - kg                         | 290            |
| Electrical Supply                   | 380-415v, 50Hz |
| Phase                               | 3              |
| Mains Cable No. Cores               | 4 + earth      |
| Starting Current (A)                | 8              |
| Running Current (A) - Heating       | 14.6           |
| Running Current (A) - Cooling       | 13.6           |
| Fuse Rating (BS88) - HRC (A)        | 25             |

## Piping Restrictions

|   |     |
|---|-----|
| Total Piping Length (m)                       | 220 |
| Furthest Piping Length (m)                    | 100 |
| Between Indoor and BC Controller - Length (m) | 30  |
| Between Indoor and Outdoor Units - Height (m) | 50  |
| Between Indoor and BC Controller - Height (m) | 15  |
| Between Indoor and Indoor Units - Height (m)  | 15  |

## Dimensions

PURY-RP300YJM-B

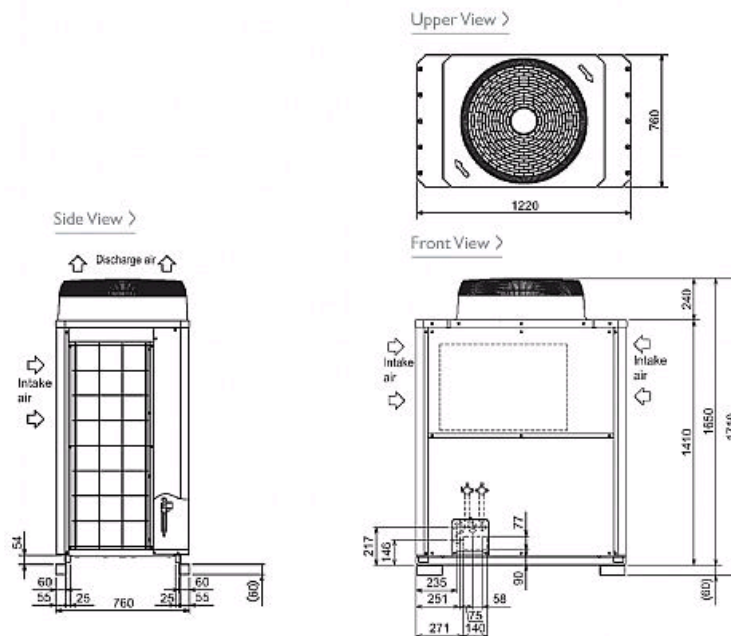

Telephone: 01707 282880

Email: [air.conditioning@meuk.mee.com](mailto:air.conditioning@meuk.mee.com) Website: <http://www.mitsubishielectric.co.uk/aircon>

Mitsubishi Electric reserves the right to make any variation in technical specification to the equipment described, or to withdraw or replace products without prior notification or public announcement.

Tel:  
Fax:

