

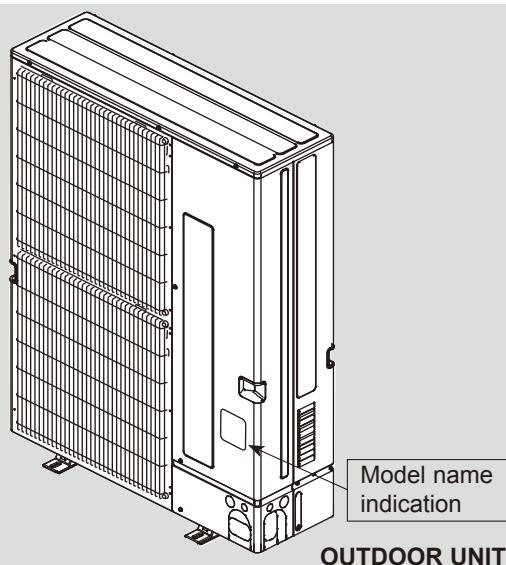

TECHNICAL & SERVICE MANUAL

<Outdoor unit>
[Model Name]
PUMY-P112VKM
PUMY-P125VKM
PUMY-P140VKM
PUMY-P112YKM
PUMY-P125YKM
PUMY-P140YKM
Salt proof model
PUMY-P112VKM-BS
PUMY-P125VKM-BS
PUMY-P140VKM-BS
PUMY-P112YKM-BS
PUMY-P125YKM-BS
PUMY-P140YKM-BS
[Service Ref.]
PUMY-P112VKM
PUMY-P125VKM
PUMY-P140VKM
PUMY-P112YKM
PUMY-P125YKM
PUMY-P140YKM
PUMY-P112VKM-BS
PUMY-P125VKM-BS
PUMY-P140VKM-BS
PUMY-P112YKM-BS
PUMY-P125YKM-BS
PUMY-P140YKM-BS
Note:

- This service manual describes technical data of the outdoor units only.

CONTENTS

1. SAFETY PRECAUTION.....	2
2. OVERVIEW OF UNITS.....	5
3. SPECIFICATIONS.....	7
4. DATA.....	9
5. OUTLINES AND DIMENSIONS.....	20
6. WIRING DIAGRAM.....	22
7. NECESSARY CONDITIONS FOR SYSTEM CONSTRUCTION.....	24
8. TROUBLESHOOTING.....	34
9. ELECTRICAL WIRING.....	123
10. REFRIGERANT PIPING TASKS.....	127
11. DISASSEMBLY PROCEDURE.....	131

PARTS CATALOG (OCB547)

1-1. CAUTIONS RELATED TO NEW REFRIGERANT

Caution for units utilizing refrigerant R410A

Use new refrigerant pipes.

Avoid using thin pipes.

Make sure that the inside and outside of refrigerant piping is clean and it has no contaminants such as sulfur, oxides, dirt, shaving particles, etc, which are hazard to refrigerant cycle. In addition, use pipes with specified thickness.

Contamination inside refrigerant piping can cause deterioration of refrigerant oil etc.

Store the piping indoors, and both ends of the piping sealed until just before brazing. (Leave elbow joints, etc. in their packaging.)

If dirt, dust or moisture enters into refrigerant cycle, that can cause deterioration of refrigerant oil or malfunction of compressor.

The refrigerant oil applied to flare and flange connections must be ester oil, ether oil or alkylbenzene oil in a small amount.

If large amount of mineral oil enters, that can cause deterioration of refrigerant oil etc.

Charge refrigerant from liquid phase of gas cylinder.

If the refrigerant is charged from gas phase, composition change may occur in refrigerant and the efficiency will be lowered.

Do not use refrigerant other than R410A.

If other refrigerant (R22 etc.) is used, chlorine in refrigerant can cause deterioration of refrigerant oil etc.

Use a vacuum pump with a reverse flow check valve.

Vacuum pump oil may flow back into refrigerant cycle and that can cause deterioration of refrigerant oil etc.

Use the following tools specifically designed for use with R410A refrigerant.

The following tools are necessary to use R410A refrigerant.

Tools for R410A	
Gauge manifold	Flare tool
Charge hose	Size adjustment gauge
Gas leak detector	Vacuum pump adaptor
Torque wrench	Electronic refrigerant charging scale

Handle tools with care.

If dirt, dust or moisture enters into refrigerant cycle, that can cause deterioration of refrigerant oil or malfunction of compressor.

Do not use a charging cylinder.

If a charging cylinder is used, the composition of refrigerant will change and the efficiency will be lowered.

Ventilate the room if refrigerant leaks during operation. If refrigerant comes into contact with a flame, poisonous gases will be released.

Use the specified refrigerant only.

Never use any refrigerant other than that specified.

Doing so may cause a burst, an explosion, or fire when the unit is being used, serviced, or disposed of.

Correct refrigerant is specified in the manuals and on the spec labels provided with our products.

We will not be held responsible for mechanical failure, system malfunction, unit breakdown or accidents caused by failure to follow the instructions.

[1] Cautions for service

- (1) Perform service after recovering the refrigerant left in unit completely.
- (2) Do not release refrigerant in the air.
- (3) After completing service, charge the cycle with specified amount of refrigerant.
- (4) When performing service, install a filter drier simultaneously.
Be sure to use a filter drier for new refrigerant.

[2] Additional refrigerant charge

When charging directly from cylinder

- Check that cylinder for R410A on the market is syphon type.
- Charging should be performed with the cylinder of syphon stood vertically. (Refrigerant is charged from liquid phase.)

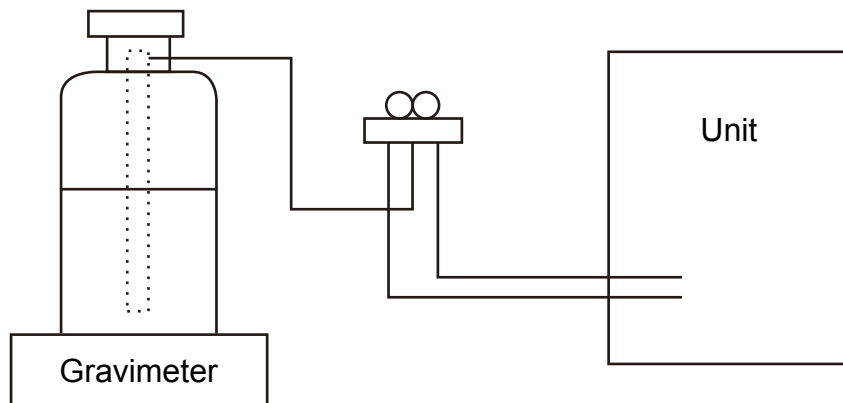

[3] Service tools

Use the below service tools as exclusive tools for R410A refrigerant.

No.	Tool name	Specifications
①	Gauge manifold	· Only for R410A
		· Use the existing fitting specifications. (UNF1/2)
		· Use high-tension side pressure of 5.3MPa·G or over.
②	Charge hose	· Only for R410A
		· Use pressure performance of 5.09MPa·G or over.
③	Electronic scale	—
④	Gas leak detector	· Use the detector for R134a, R407C or R410A.
⑤	Adaptor for reverse flow check	· Attach on vacuum pump.
⑥	Refrigerant charge base	—
⑦	Refrigerant cylinder	· Only for R410A · Top of cylinder (Pink)
		· Cylinder with syphon
⑧	Refrigerant recovery equipment	—

1-2. PRECAUTIONS FOR SALT PROOF TYPE "-BS" MODEL

Although "-BS" model has been designed to be resistant to salt damage, observe the following precautions to maintain the performance of the unit.

1. Avoid installing the unit in a location where it will be exposed directly to seawater or sea breeze.
2. If the cover panel may become covered with salt, be sure to install the unit in a location where the salt will be washed away by rainwater. (If a sunshade is installed, rainwater may not clean the panel.)
3. To ensure that water does not collect in the base of the outdoor unit, make sure that the base is level, not at angle. Water collecting in the base of the outdoor unit could cause rust.
4. If the unit is installed in a coastal area, clean the unit with water regularly to remove any salt build-up.
5. If the unit is damaged during installation or maintenance, be sure to repair it.
6. Be sure to check the condition of the unit regularly.
7. Be sure to install the unit in a location with good drainage.

Cautions for refrigerant piping work

New refrigerant R410A is adopted for replacement inverter series. Although the refrigerant piping work for R410A is same as for R22, exclusive tools are necessary so as not to mix with different kind of refrigerant. Furthermore as the working pressure of R410A is 1.6 times higher than that of R22, their sizes of flared sections and flare nuts are different.

① Thickness of pipes

Because the working pressure of R410A is higher compared to R22, be sure to use refrigerant piping with thickness shown below. (Never use pipes of 0.7 mm or below.)

Diagram below: Piping diameter and thickness

Nominal dimensions(inch)	Outside diameter (mm)	Thickness (mm)	
		R410A	R22
1/4	6.35	0.8	0.8
3/8	9.52	0.8	0.8
1/2	12.70	0.8	0.8
5/8	15.88	1.0	1.0
3/4	19.05	—	1.0

② Dimensions of flare cutting and flare nut

The component molecules in HFC refrigerant are smaller compared to conventional refrigerants. In addition to that, R410A is a refrigerant, which has higher risk of leakage because its working pressure is higher than that of other refrigerants. Therefore, to enhance airtightness and intensity, flare cutting dimension of copper pipe for R410A has been specified separately from the dimensions for other refrigerants as shown below. The dimension B of flare nut for R410A also has partly been changed to increase intensity as shown below. Set copper pipe correctly referring to copper pipe flaring dimensions for R410A below. For 1/2 and 5/8 inch, the dimension B changes. Use torque wrench corresponding to each dimension.

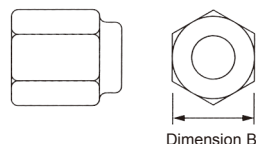
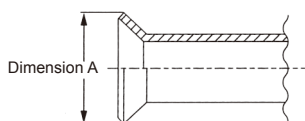

Flare cutting dimensions

Nominal dimensions(inch)	Outside diameter (mm)	Dimension A ($^{+0.4}$) (mm)	
		R410A	R22
1/4	6.35	9.1	9.0
3/8	9.52	13.2	13.0
1/2	12.70	16.6	16.2
5/8	15.88	19.7	19.4
3/4	19.05	—	23.3

Flare nut dimensions

Nominal dimensions(inch)	Outside diameter (mm)	Dimension B (mm)	
		R410A	R22
1/4	6.35	17.0	17.0
3/8	9.52	22.0	22.0
1/2	12.70	26.0	24.0
5/8	15.88	29.0	27.0
3/4	19.05	—	36.0

③ Tools for R410A (The following table shows whether conventional tools can be used or not.)

Tools and materials	Use	R410A tools	Can R22 tools be used?	Can R407C tools be used?
Gauge manifold	Air purge, refrigerant charge and operation check	Tool exclusive for R410A	×	×
Charge hose	Gas leak check	Tool exclusive for R410A	×	×
Gas leak detector	Refrigerant recovery	Tool for HFC refrigerant	×	○
Refrigerant recovery equipment	Refrigerant charge	Tool exclusive for R410A	×	×
Refrigerant cylinder	Apply to flared section	Tool exclusive for R410A	×	×
Applied oil	Prevent compressor malfunction when charging refrigerant by spraying liquid refrigerant	Ester oil, ether oil and alkylbenzene oil (minimum amount)	×	Ester oil, ether oil: ○ Alkylbenzene oil: minimum amount
Safety charger	Prevent gas from blowing out when detaching charge hose	Tool exclusive for R410A	×	×
Charge valve	Vacuum drying and air purge	Tools for other refrigerants can be used if equipped with adopter for reverse flow check	△ (Usable if equipped with adopter for reverse flow)	△ (Usable if equipped with adopter for reverse flow)
Vacuum pump	Flaring work of piping	Tools for other refrigerants can be used by adjusting flaring dimension	△ (Usable by adjusting flaring dimension)	△ (Usable by adjusting flaring dimension)
Flare tool	Bend the pipes	Tools for other refrigerants can be used	○	○
Bender	Cut the pipes	Tools for other refrigerants can be used	○	○
Pipe cutter	Weld the pipes	Tools for other refrigerants can be used	○	○
Welder and nitrogen gas cylinder	Refrigerant charging	Tools for other refrigerants can be used	○	○
Refrigerant charging scale	Check the degree of vacuum. (Vacuum valve prevents back flow of oil and refrigerant to thermistor vacuum gauge)	Tools for other refrigerants can be used	○	○
Vacuum gauge or thermistor vacuum gauge and vacuum valve	Refrigerant charge	Tool exclusive for R410A	×	—
Charging cylinder				

× : Prepare a new tool. (Use the new tool as the tool exclusive for R410A.)

△ : Tools for other refrigerants can be used under certain conditions.

○ : Tools for other refrigerants can be used.

2-1. UNIT CONSTRUCTION

Outdoor unit		4HP	5HP	6HP
		PUMY-P112VKM(-BS) PUMY-P112YKM(-BS)	PUMY-P125VKM(-BS) PUMY-P125YKM(-BS)	PUMY-P140VKM(-BS) PUMY-P140YKM(-BS)
Applicable indoor unit	Capacity	Type 15 ~ Type 125		Type 15 ~ Type 140
	Number of units	1 ~ 9 unit	1 ~ 10 unit	1 ~ 12 unit
	Total system wide capacity	50% ~130% of outdoor unit capacity *2 *3		

	CMY-Y62-G-E	CMY-Y64-G-E	CMY-Y68-G-E
Branching pipe components	Branch header (2 branches)	Branch header (4 branches)	Branch header (8 branches)

Model Capacity	Cassette Ceiling			Ceiling Concealed	Wall Mounted	Ceiling Suspended	Floor standing		Ceiling Concealed (Fresh Air) *1	Air to Water Unit *3	CONNECTION KIT PAC-LV11M-J
	4-way flow	2-way flow	1-way flow				Exposed	Concealed			
15	PLFY-P	PLFY-P	PMFY-P	PEFY-P	PKFY-P	PCFY-P	PFFY-P	PFFY-P	PEFY-P	PWFY-P	M series indoor unit *4 MSZ-SF Series MSZ-EF Series MSZ-FH Series
20	20VCM-E(2)	20VLMD-E	20VBM-E	15VMS1(L)-E / VMA(L)-E	15VBM-E	-	20VLEM-E VKM-E(2)	20VLRM-E	-	-	
25	25VCM-E(2)	25VLMD-E	25VBM-E	25VMS1(L)-E / VMA(L)-E	25VBM-E	-	25VLEM-E VKM-E(2)	25VLRM-E	-	-	
32	32VCM-E(2) 32VBM-E	32VLMD-E	32VBM-E	32VMS1(L)-E / VMA(L)-E	32VHM-E	-	32VLEM-E VKM-E(2)	32VLRM-E	-	-	
40	40VCM-E(2) 40VBM-E	40VLMD-E	40VBM-E	40VMS1(L)-E / VMA(L)-E / VMH-E	40VHM-E	40VKM-E	40VLEM-E VKM-E(2)	40VLRM-E	-	-	
50	50VBM-E	50VLMD-E	-	50VMS1(L)-E / VMA(L)-E / VMH-E	50VHM-E	-	50VLEM-E	50VLRM-E	-	-	
63	63VBM-E	63VLMD-E	-	63VMS1(L)-E / VMA(L)-E / VMH-E	63VKM-E	63VKM-E	63VLEM-E	63VLRM-E	-	-	
71	-	-	-	71VMA(L)-E / VMH	-	-	-	-	-	-	
80	80VBM-E	80VLMD-E	-	80VMH-E / VMA(L)-E	-	-	-	-	80VMH-E-F	-	
100	100VBM-E	100VLMD-E	-	100VMH-E / VMA(L)-E	100VKM-E	100VKM-E	-	-	-	100VM-E-AU	
125	125VBM-E	125VLMD-E	-	125VMH-E / VMA(L)-E	-	125VKM-E	-	-	-	-	
140	-	-	-	140VMH-E / VMA(L)-E	-	-	-	-	140VMH-E-F	-	

Decorative panel

Remote controller	Name	M-NET remote controller	MA remote controller	M series remote controller
	Model number	PAR-F27MEA-E	PAR-21MAA, PAR-30MAA PAR-W21MAA(when using PWFY)	
	Functions	<ul style="list-style-type: none"> A handy remote controller for use in conjunction with the Melans centralized management system. Addresses must be set. 	<ul style="list-style-type: none"> Addresses setting is not necessary. 	

*1. PUMY is connectable to Fresh Air type indoor unit.

It is possible to connect 1 Fresh Air type indoor unit to 1 outdoor unit. (1:1 system)

Operating temperature range (outdoor temperature) for fresh air type indoor units differ from other indoor units.

Refer to "2-2-(3). Operating temperature range".

*2. When the indoor unit of Fresh Air type is connected with the outdoor unit, the maximum connectable total indoor unit capacity is 110% (100% in case of heating below -5 °C [23 °F]).

*3. When connecting PWFY series

• Only 1 PWFY-P100VM-E-AU can be connected. PWFY-P200VM-E-AU and PWFY-P100VM-E-BU cannot be connected.

• The PWFY unit cannot be the only unit connected to an outdoor unit. Select an indoor unit so that the total rated capacity of the indoor units, excluding the PWFY unit, is 50 to 100% of the outdoor unit capacity.

*4. When connecting the CONNECTION KIT (PAC-LV11M-J) and an M-series indoor unit, refer to the installation manual for the CONNECTION KIT.

2-2. UNIT SPECIFICATIONS

(1) Outdoor Unit

Service Ref.		PUMY-P112VKM(-BS) PUMY-P112YKM(-BS)	PUMY-P125VKM(-BS) PUMY-P125YKM(-BS)	PUMY-P140VKM(-BS) PUMY-P140YKM(-BS)
Capacity	Cooling (kW)	11.2	14.0	15.5
	Heating (kW)	12.5	16.0	18.0
Compressor (kW)		2.9	3.5	3.9

Cooling/Heating capacity indicates the maximum value at operation under the following condition.

*Cooling Indoor : D.B. 27 °C/ W.B. 19.0 °C
Outdoor : D.B. 35 °C
Heating Indoor : D.B. 20 °C
Outdoor : D.B. 7 °C/ W.B. 6 °C

(2) Method for identifying MULTI-S model

■ Indoor unit < When using Model 80 >

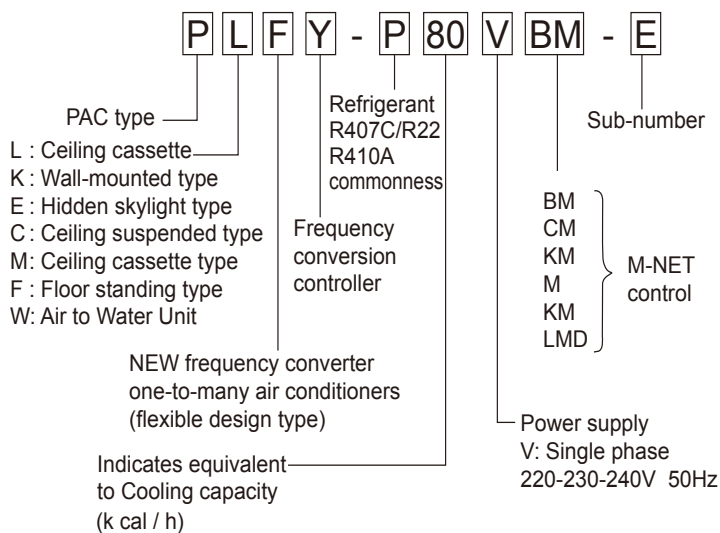

■ Outdoor unit <When using model 125 >

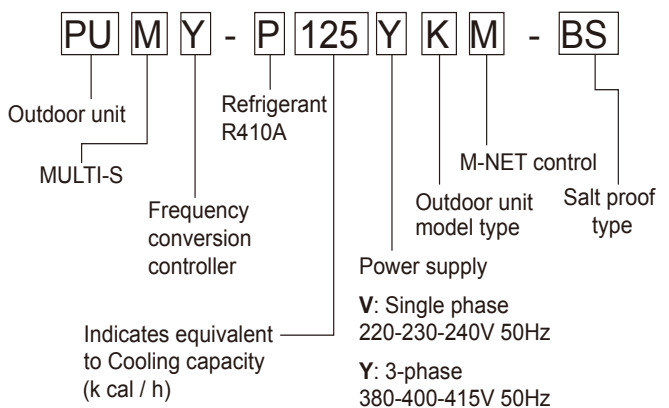

(3) Operating temperature range

	Cooling	Heating
Indoor-side intake air temperature	W.B. 15 to 24 °C	D.B. 15 to 27 °C
Outdoor-side intake air temperature	D.B. -5 to 46 °C*	W.B. -20 to 15 °C

Notes D.B. : Dry Bulb Temperature
W.B. : Wet Bulb Temperature

*10~46 °C D.B. : When connecting PKFY-P15/P20/P25VBM, PFFY-P20/25/32VKM and PFFY-P20/25/32 VLE(R)M type indoor unit.

■ When connecting fresh air type indoor unit

	Capacity of Fresh air type indoor	Cooling	Heating
Indoor-side and Outdoor-side intake air temperature	P80	D.B. 21 to 43 °C* W.B. 15.5 to 35 °C	D.B. -10 to 20 °C**
	P140	D.B. 21 to 43 °C* W.B. 15.5 to 35 °C	D.B. -5 to 20 °C**

*Thermo-OFF (FAN-mode) automatically starts if the outdoor temp. is lower than 21 °C D.B..

**Thermo-OFF (FAN-mode) automatically starts if the outdoor temp. is higher than 20 °C D.B..

■ When connecting Air to Water Unit

	Cooling	Heating
Indoor-side intake water temperature	— *1	D.B. 10 to 45 °C
Outdoor-side intake air temperature	— *1	W.B. -20 to 15 °C

*1: • PWFY series can operate in Heating mode but not in Cooling mode. An indoor unit other than that of PWFY series can operate in Cooling mode.

- A PWFY series and other series cannot operate simultaneously.
- The operation of PWFY series takes precedence over other series. While a PWFY series is operating, other series do not operate.
- The set temperature on the remote controller represents the target temperature of the outlet water.

3

SPECIFICATIONS

Model		PUMY-P112VKM(-BS)	PUMY-P125VKM(-BS)	PUMY-P140VKM(-BS)	
Power source		1-phase 220-240 V 50 Hz			
Cooling capacity (Nominal)	kW *1	12.5	14.0	15.5	
		kcal/h *1	10,750	12,040	13,330
		BTU/h *1	42,650	47,768	52,886
	Power input	kW	2.79	3.46	4.52
	Current input	A	12.87/12.32/11.80	15.97/ 15.27/ 14.64	20.86/19.95/19.12
COP	kW/kW	4.48	4.05	3.43	
Temp. range of cooling	Indoor temp.	W.B.	15 to 24 °C		
	Outdoor temp.	D.B.	-5 to 46 °C		
Heating capacity (Nominal)	kW *2	14.0	16.0	18.0	
		kcal/h *2	12,040	13,760	15,480
		BTU/h *2	47,768	54,592	61,416
	Power input	kW	3.04	3.74	4.47
	Current input	A	14.03/ 13.42/ 12.86	17.26/ 16.51/ 15.82	20.63/ 19.73/ 18.91
COP	kW/kW	4.61	4.28	4.03	
Temp. range of heating	Indoor temp.	D.B.	15 to 27 °C		
	Outdoor temp.	W.B.	-20 to 15 °C		
Indoor unit connectable	Total capacity	50 to 130% of outdoor unit capacity			
	Model / Quantity	15 - 125/9	15 - 140 /10	15 - 140 /12	
Sound pressure level (measured in anechoic room)	dB <A>	49/ 51	50/ 52	51/ 53	
Power pressure level (measured in anechoic room)	dB <A>	-	-	-	
Refrigerant piping diameter	Liquid pipe	mm (in)	9.52 (3/8)		
	Gas pipe	mm (in)	15.88 (5/8)		
FAN *2	Type x Quantity		Propeller Fan x 2		
	Air flow rate	m3/min	110		
		L/s	1,833		
		cfm	3,884		
	Control, Driving mechanism		DC control		
	Motor output	kW	0.06+0.06		
	External static press.		0		
Compressor	Type x Quantity		Scroll hermetic compressor x 1		
	Manufacture		Mitsubishi Electric Corporation		
	Starting method		Inverter		
	Capacity control	%	Cooling 26 to 100 Heating 20 to 100	Cooling 24 to 00 Heating 18 to 100	Cooling 21 to 100 Heating 17 to 100
	Motor output	kW	2.9	3.5	3.9
	Case heater	kW	0		
	Lubricant		FV50S(2.3liter)		
External finish		Galvanized Steel Sheet Munsell No. 3Y 7.8/1.1			
External dimension HxWxD	mm	1,338 x 1,050 x 330(+25)			
	in	52-11/16 x 41-11/ 32 x 13 (+1)			
Protection devices	High pressure protection		High pressure Switch		
	Inverter circuit (COMP./FAN)		Overcurrent detction, Overheat detection(Heat Sink thermistor)		
	Compressor		Compressor thermistor, Over current detection		
	Fan motor		Overheating, Voltage protection		
Refrigerant	Type x original charge		R410A 4.8kg		
	Control		Electronic Expansion Valve		
Net weight	kg (lbs)	123 (271)			
Heat exchanger		Cross Fin and Copper tube			
HIC circuit (HIC: Heat Inter-Changer)		HIC circuit			
Defrosting method		Reversed refrigerant circuit			
Drawing	External	BK01N346			
	Wiring	BH78B813			
Standard attachment	Document	Installation Manual			
	Accessory	Grounded lead wire x2			
Optional parts		Joint: CMY-Y62-G-E Header: CMY-Y64/68-G-E			
Remarks					
* 1 Nominal cooling conditions		* 2 Nominal heating conditions			
Indoor :	27 °C D.B./19 °C W.B. (81 °F D.B./66 °F W.B.)	20 °C D.B. (68 °F D.B.)			
Outdoor :	35 °C D.B. (95 °F D.B.)	7°C DB/6°C W.B. (45 °F D.B./43 °F W.B.)			
Pipe length :	7.5 m (24-9/16 ft)	7.5 m (24-9/16 ft)			
Level difference :	0 m (0 ft)	0 m (0 ft)			
Note : 1. Nominal conditions * 1, * 2 are subject to ISO 15042. 2. Due to continuing improvement, above specifications may be subject to change without notice.		Unit converter kcal/h = kW × 860 BTU/h = kW × 3,412 cfm = m3/min x 35.31 lb = kg/0.4536 Above specification data is subject to rounding variation.			



Model			PUMY-P112YKM(-BS)	PUMY-P125YKM(-BS)	PUMY-P140YKM(-BS)
Power source			3-phase380-415V, 50Hz		
Cooling capacity (Nominal)		kW *1	12.5	14.0	15.5
		kcal/h *1	10,750	12,040	13,330
		BTU/h *1	42,650	47,768	52,886
	Power input	kW	2.79	3.46	4.52
	Current input	A	4.46/ 4.24/ 4.09	5.53/ 5.26/ 5.07	7.23/ 6.87/ 6.62
	COP	kW/kW	4.48	4.05	3.43
Temp. range of cooling	Indoor temp.	W.B.	15 to 24 °C		
	Outdoor temp.	D.B.	-5 to 46 °C		
Heating capacity (Nominal)		kW *2	14.0	16.0	18.0
		kcal/h *2	12,040	13,760	15,480
		BTU/h *2	47,768	54,592	61,416
	Power input	kW	3.04	3.74	4.47
	Current input	A	4.86/ 4.62/ 4.45	5.98/ 5.68/ 5.48	7.15/ 6.79/ 6.55
	COP	kW/kW	4.61	4.28	4.03
Temp. range of heating	Indoor temp.	D.B.	15 to 27°C		
	Outdoor temp.	W.B.	-20 to 15°C		
Indoor unit connectable	Total capacity		50 - 130% of outdoor unit capacity		
	Model / Quantity		15 - 125 /9	15 - 140 /10	15 - 140 /12
Sound pressure level (measured in anechoic room)		dB <A>	49/ 51	50/ 52	51/ 53
Power pressure level (measured in anechoic room)		dB <A>	-	-	-
Refrigerant piping diameter	Liquid pipe	mm (in)	9.52 (3/8)		
	Gas pipe	mm (in)	15.88 (5/8)		
FAN *2	Type x Quantity		Propeller Fan x 2		
	Air flow rate	m3/min	110		
		L/s	1,833		
		cfm	3,884		
	Control, Driving mechanism		DC control		
	Motor output	kW	0.06+0.06		
External static press.		0			
Compressor	Type x Quantity		Scroll hermetic compressor x 1		
	Manufacture		Mitsubishi Electric Corporation		
	Starting method		Inverter		
	Capacity control	%	Cooling 26 to 100 Heating 20 to 100	Cooling 24 to 100 Heating 18 to 100	Cooling 21 to 100 Heating 17 to 100
	Motor output	kW	2.9	3.5	3.9
	Case heater		kW		
Lubricant		FV50S(2.3litter)			
External finish			Galvanized Steel Sheet Munsell No. 3Y 7.8/1.1		
External dimension HxWxD	mm		1338 x 1050 x 330(+25)		
	in		52-11/16 x 41-11/32 x 13 (+1)		
Protection devices	High pressure protection		High pressure Switch		
	Inverter circuit (COMP/FAN)		Overcurrent detection, Overheat detection(Heat Sink thermistor)		
	Compressor		Compressor thermistor, Over current detection		
	Fan motor		Overheating, Voltage protection		
Refrigerant	Type x original charge		R410A 4.8kg		
	Control		Electronic Expansion Valve		
Net weight	kg (lb)		125 (276)		
Heat exchanger			Cross Fin and Copper tube		
HIC circuit (HIC: Heat Inter-Changer)			HIC circuit		
Defrosting method			Reversed refrigerant circuit		
Drawing	External		BK01N339		
	Wiring		BH78B814		
Standard attachment	Document		Installation Manual		
	Accessory		Grounded lead wire x2		
Optional parts			Joint: CMY-Y62-G-E Header: CMY-Y64/68-G-E		
Remarks					

<p>* 1 Nominal cooling conditions * 2 Nominal heating conditions</p> <p>Indoor : 27 °C D.B./19 °C W.B. (81 °F D.B./66 °F W.B.) 20 °C D.B. (68 °F D.B.)</p> <p>Outdoor : 35 °C D.B. (95 °F D.B.) 7°C DB/6°C W.B. (45 °F D.B./43 °F W.B.)</p> <p>Pipe length : 7.5 m (24-9/16 ft) 7.5 m (24-9/16 ft)</p> <p>Level difference : 0 m (0 ft) 0 m (0 ft)</p> <p>Note : 1. Nominal conditions * 1, * 2 are subject to ISO 15042. 2. Due to continuing improvement, above specifications may be subject to change without notice.</p>	<p>Unit converter</p> <p>kcal/h = kW × 860 BTU/h = kW × 3,412 cfm = m3/min × 35.31 lb = kg/0.4536</p> <p>Above specification data is subject to rounding variation.</p>
--	---

4-1. COOLING AND HEATING CAPACITY AND CHARACTERISTICS

4-1-1. Method for obtaining system cooling and heating capacity:

To obtain the system cooling and heating capacity and the electrical characteristics of the outdoor unit, first add up the ratings of all the indoor units connected to the outdoor unit (see table below), and then use this total to find the standard capacity with the help of the tables on 4-3. STANDARD CAPACITY DIAGRAM.

(1) Capacity of indoor unit

P•FY Series	Model Number for indoor unit	Model 15	Model 20	Model 25	Model 32	Model 40	Model 50	Model 63	Model 71	Model 80	Model 100	Model 125	Model 140
	Model Capacity	1.7	2.2	2.8	3.6	4.5	5.6	7.1	8.0	9.0	11.2	14.0	16.0
M Series	Model Number for indoor unit	Model 15	Model 20	Model 22	Model 25	Mod 35	Model 42	Model 50	Model 60	Model 71	-	-	-
	Model Capacity	1.5	2.0	2.2	2.5	3.5	4.2	5.0	6.0	7.1	-	-	-

(2) Sample calculation

- ① System assembled from indoor and outdoor unit (in this example the total capacity of the indoor units is greater than that of the outdoor unit)
 - Outdoor unit PUMY-P125YKM
 - Indoor unit PKFY-P25VBM-E × 2 , PLFY-P50VLMD-E × 2
- ② According to the conditions in ①, the total capacity of the indoor unit will be: $2.8 \times 2 + 5.6 \times 2 = 16.8$
- ③ The following figures are obtained from the 16.8 total capacity of indoor units, referring the standard capacity diagram in "4-3-3. PUMY-P125VKM(-BS) PUMY-P125YKM(-BS) <cooling>" and "4-3-4. PUMY-P125VKM(-BS) PUMY-P125YKM(-BS) <heating>" :

Capacity (kW)		Outdoor unit power consumption (kW)		Outdoor unit current (A)/400V	
Cooling	Heating	Cooling	Heating	Cooling	Heating
Ⓐ 14.60	Ⓑ 16.33	3.51	3.44	5.34	5.23

4-1-2. Method for obtaining the heating and cooling capacity of an indoor unit:

(1) The capacity of each indoor unit (kW) = the capacity Ⓐ (or Ⓑ) × $\frac{\text{model capacity}}{\text{total model capacity of all indoor units}}$

(2) Sample calculation (using the system described above in 4-1-1. (2)):

During cooling:

- The total model capacity of the indoor unit is:
 $2.8 \times 2 + 5.6 \times 2 = 16.8\text{kW}$
 Therefore, the capacity of PKFY-P25VBM-E and PLFY-P50VLMD-E will be calculated as follows by using the formula in 4-1-2. (1):

$$\text{Model 25} = 14.6 \times \frac{2.8}{16.8} = 2.43\text{kW}$$

$$\text{Model 50} = 14.6 \times \frac{5.6}{16.8} = 4.87\text{kW}$$

During heating:

- The total model capacity of indoor unit is:
 $3.2 \times 2 + 6.3 \times 2 = 19.0$
 Therefore, the capacity of PKFY-P25VBM-E and PLFY-P50VLMD-E will be calculated as follows by using the formula in 4-1-2. (1):

$$\text{Model 25} = 16.33 \times \frac{3.2}{19.0} = 2.75\text{kW}$$

$$\text{Model 50} = 16.33 \times \frac{6.3}{19.0} = 5.41\text{kW}$$

4-2. STANDARD OPERATION DATA (REFERENCE DATA)

Operation			PUMY-P112VKM/YKM(-BS)		PUMY-P125VKM/YKM(-BS)		PUMY-P140VKM/YKM(-BS)		
Operating conditions	Ambient temperature	Indoor	DB/ WB	27 °C/ 19 °C	20 °C/ —	27 °C/ 19 °C	20 °C/ —	27 °C/ 19 °C	20 °C/ —
		Outdoor		35 °C	7 °C/ 6 °C	35 °C	7 °C/ 6 °C	35 °C	7 °C/ 6 °C
	Indoor unit	No. of connected units	Unit	2		2		2	
		No. of units in operation		2		2		2	
	Piping	Model	—	50 x 1/ 63 x 1		63 x 2		63 x 1 / 80x1	
		Main pipe	m	5		5		5	
		Branch pipe		2.5		2.5		2.5	
	Total pipe length	10		10		10			
	Fan speed	—		Hi		Hi		Hi	
	Amount of refrigerant	kg		7.2		7.2		7.2	
Outdoor unit	Electric current	A	16.17/ 5.26	17.38/ 5.67	21.67/ 7.12	21.91/ 7.22	25.84/ 8.58	25.54/ 8.48	
	Voltage	V	230/ 400		230/ 400		230/ 400		
	Compressor frequency	Hz	67	69	84	86	96	96	
LEV opening	Indoor unit	Pulse	357	421	447	525	511	586	
Pressure	High pressure/Low pressure	MPa	2.70/ 0.94	2.86/ 0.70	2.86/ 0.88	2.87/ 0.67	2.95/ 0.85	2.95/ 0.65	
Temp. of each section	Outdoor unit	Discharge	°C	67.0	71.9	69.7	72.1	70.7	73.2
		Heat exchanger outlet		40.2	2.0	40.8	1.3	43.7	0.9
		Accumulator inlet		8.7	1.0	8.0	0.2	5.6	-0.6
		Compressor inlet		10.7	1.3	9.1	0.1	7.8	-0.7
	Indoor unit	LEV inlet		18.9	32.4	17.7	33.0	17.0	33.4
		Heat exchanger inlet		12.3	55.5	11.1	55.7	10.4	56.8

4-3. STANDARD CAPACITY DIAGRAM

Before calculating the sum of total capacity of indoor units, please convert the value into the kW model capacity following the formula on "4-1-1. Method for obtaining system cooling and heating capacity".

4-3-1. PUMY-P112VKM(-BS) PUMY-P112YKM(-BS) <cooling>

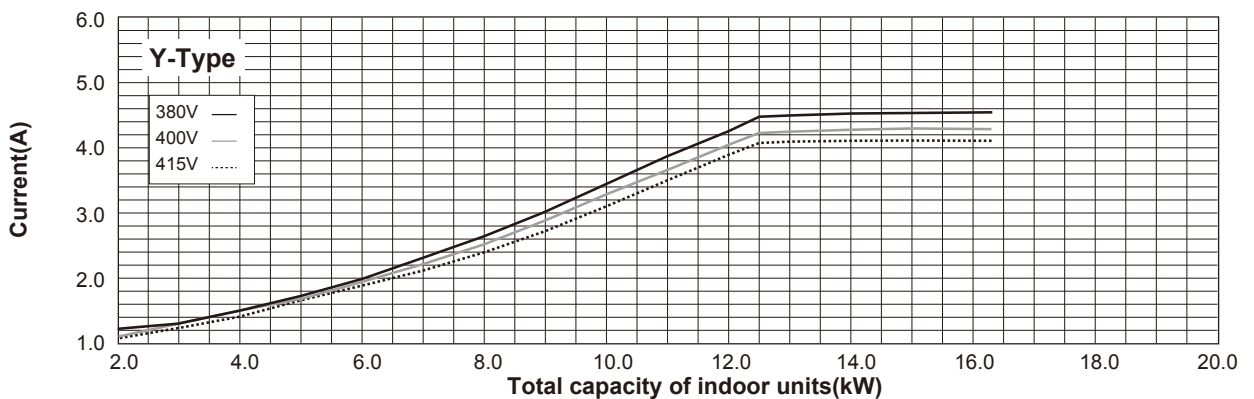
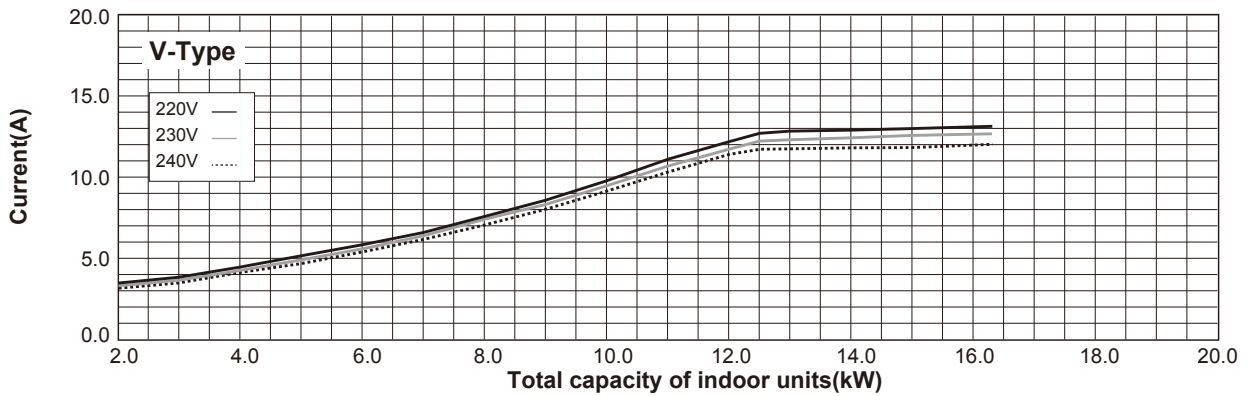
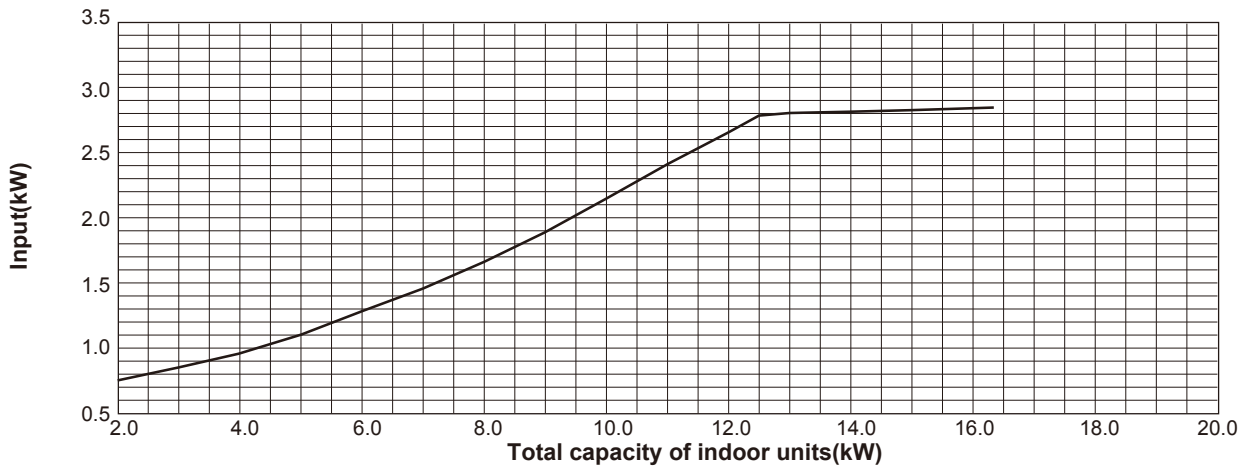
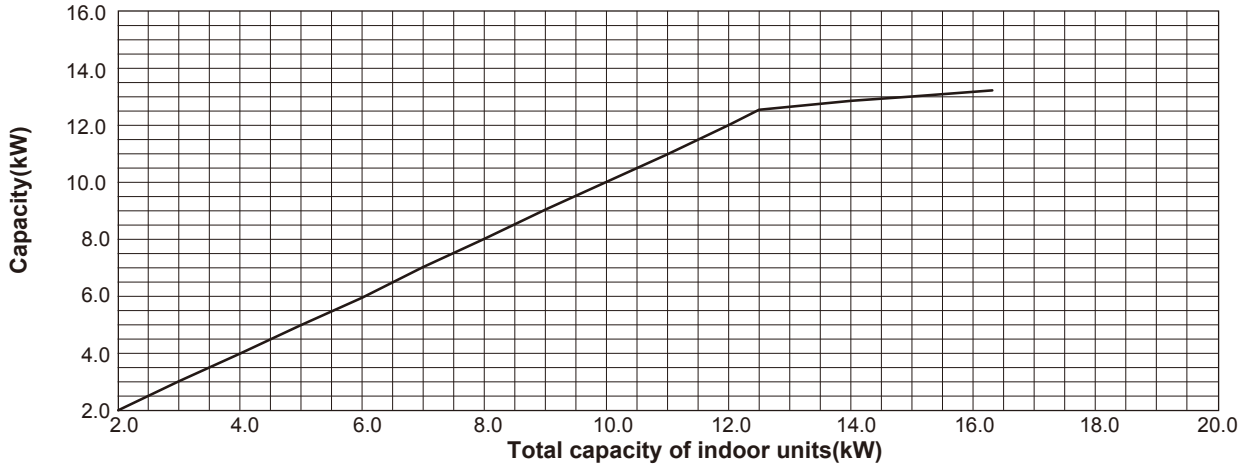

4-3-2. PUMY-P112VKM(-BS) PUMY-P112YKM(-BS) <heating>

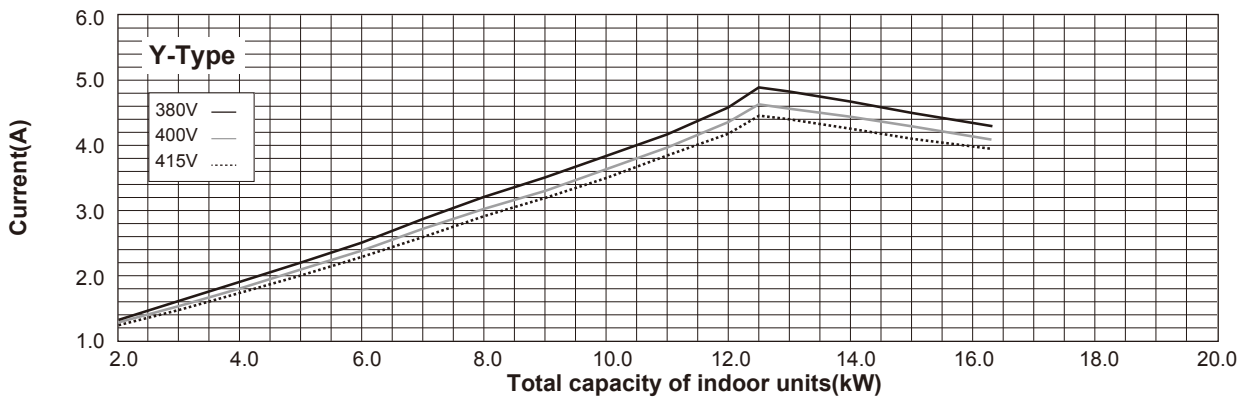
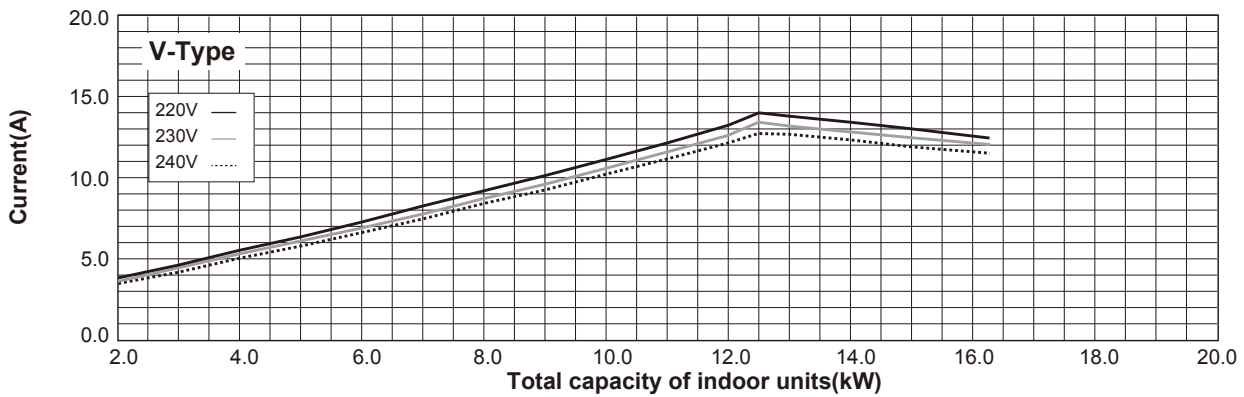
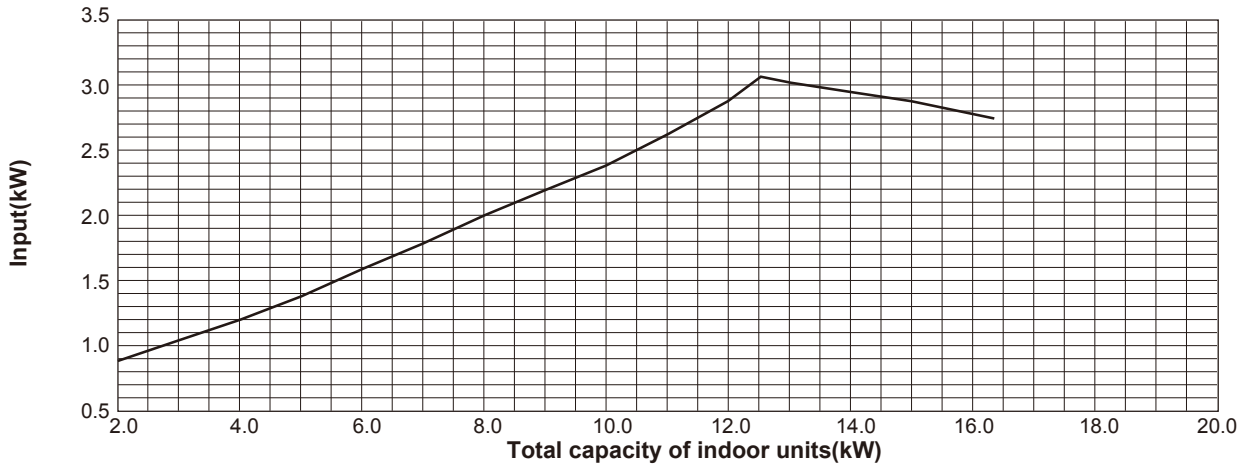
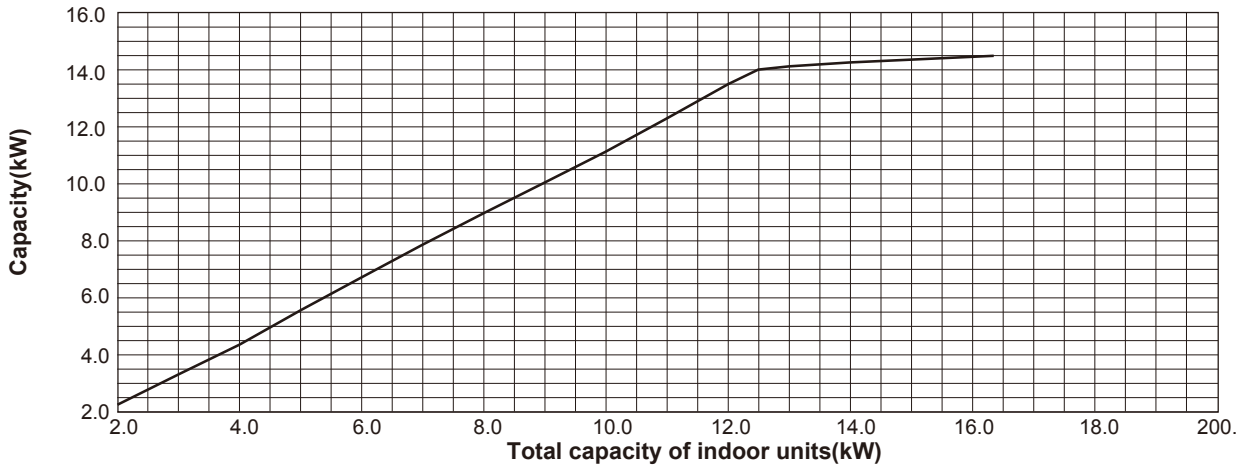

4-3-3. PUMY-P125VKM(-BS) PUMY-P125YKM(-BS) <cooling>

Before calculating the sum of total capacity of indoor units, please convert the value into the kW model capacity following the formula on "4-1-1. Method for obtaining system cooling and heating capacity".

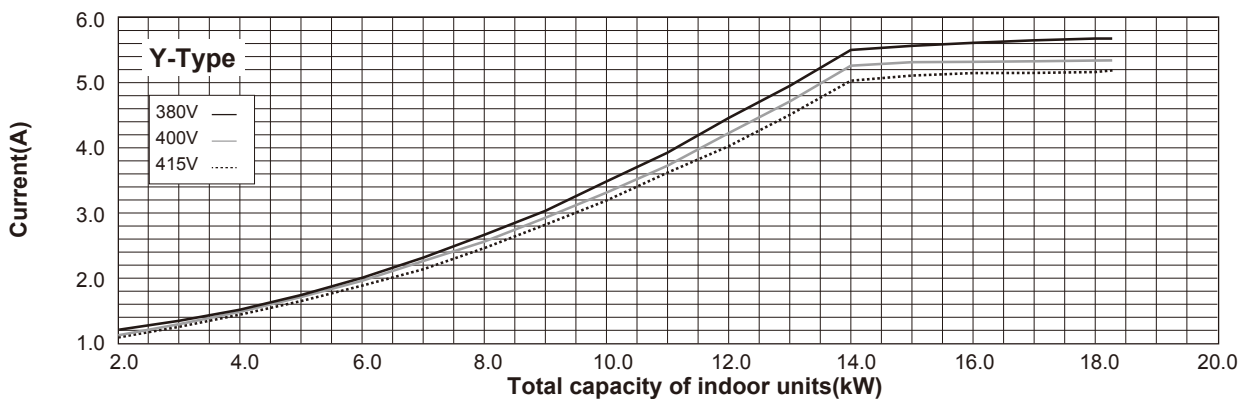
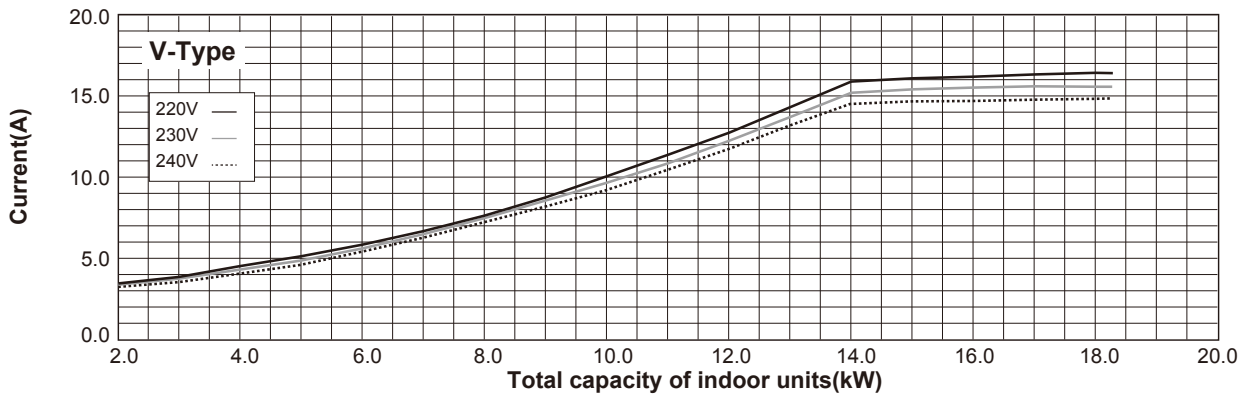
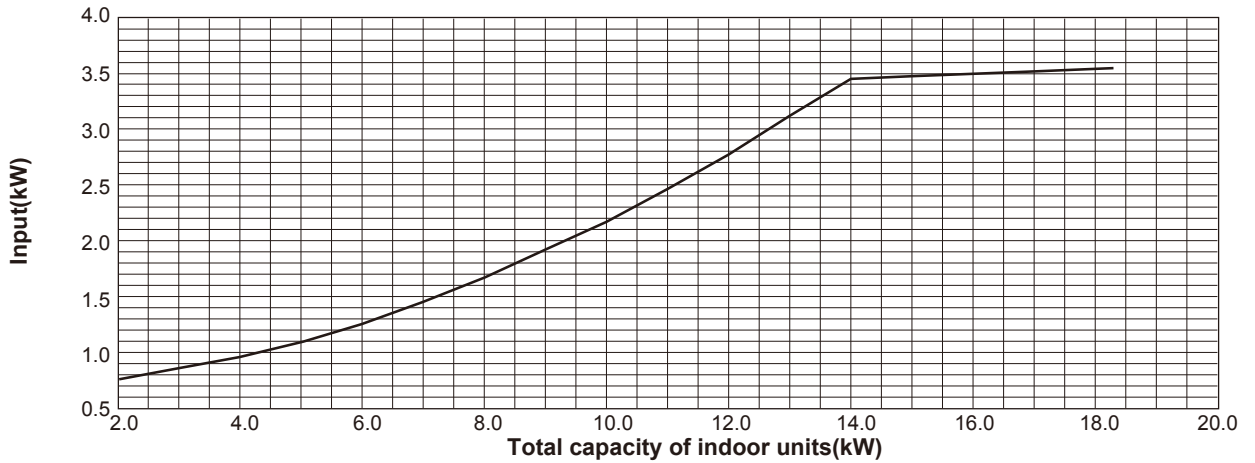
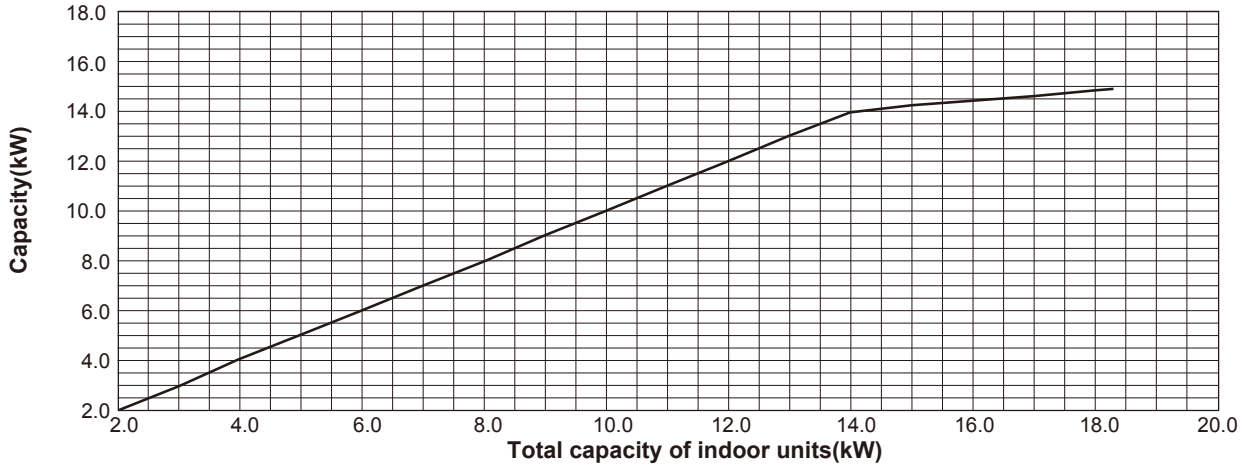

4-3-4. PUMY-P125VKM(-BS) PUMY-P125YKM(-BS) <heating>

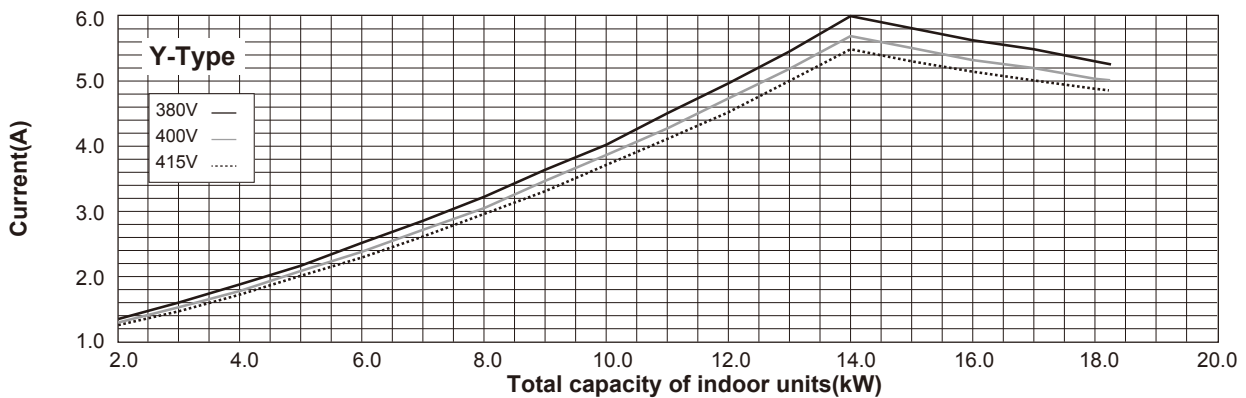
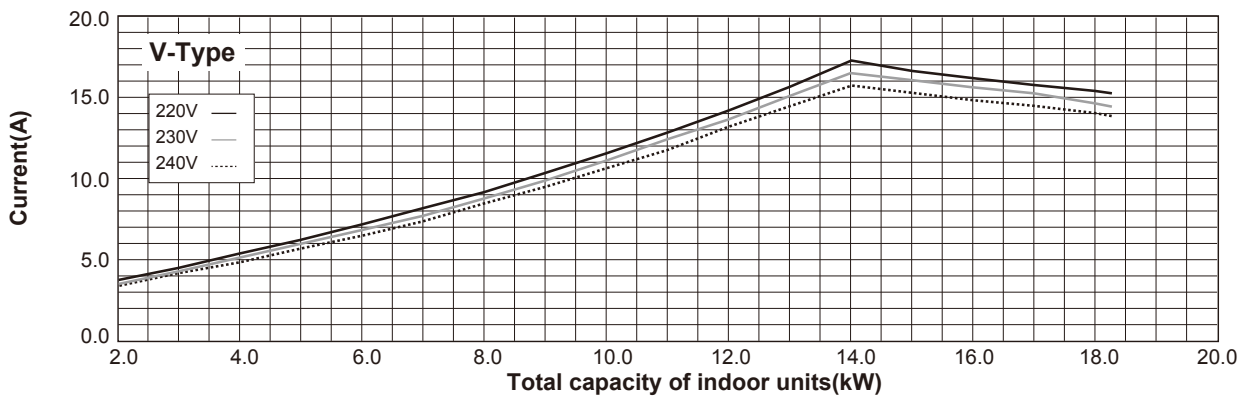
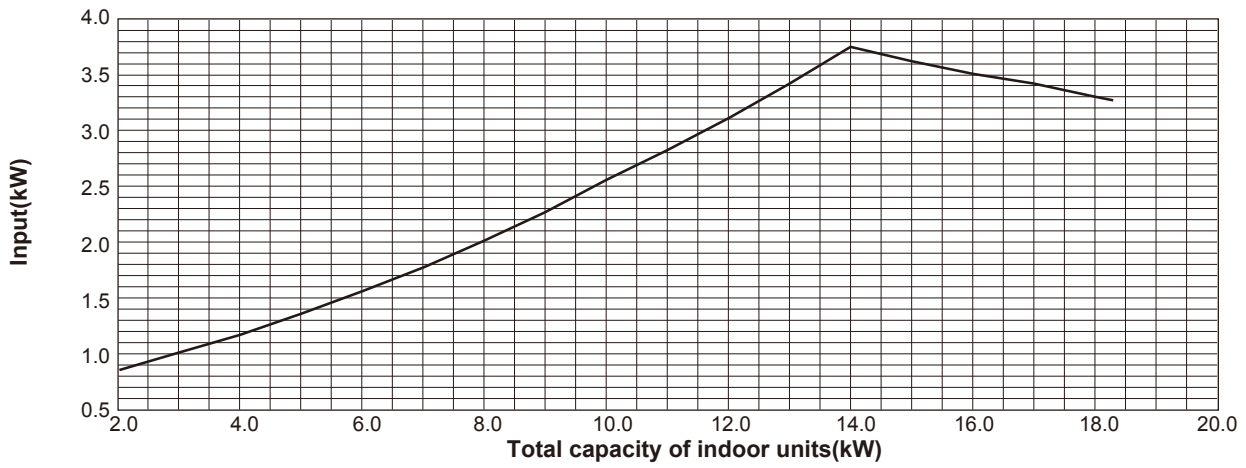
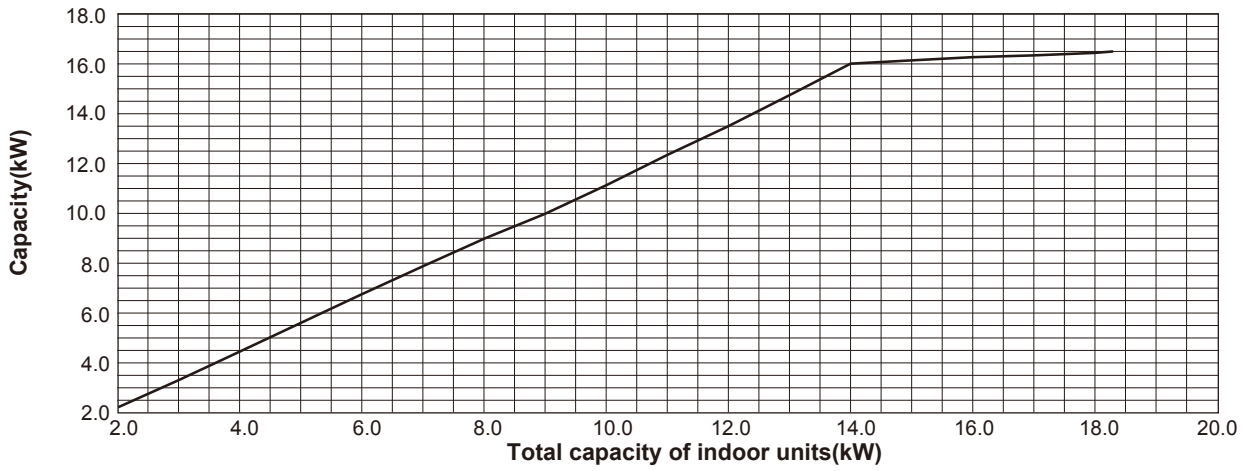

4-3-5. PUMY-P140VKM(-BS) PUMY-P140YKM(-BS) <cooling>

Before calculating the sum of total capacity of indoor units, please convert the value into the kW model capacity following the formula on "4-1-1. Method for obtaining system cooling and heating capacity".

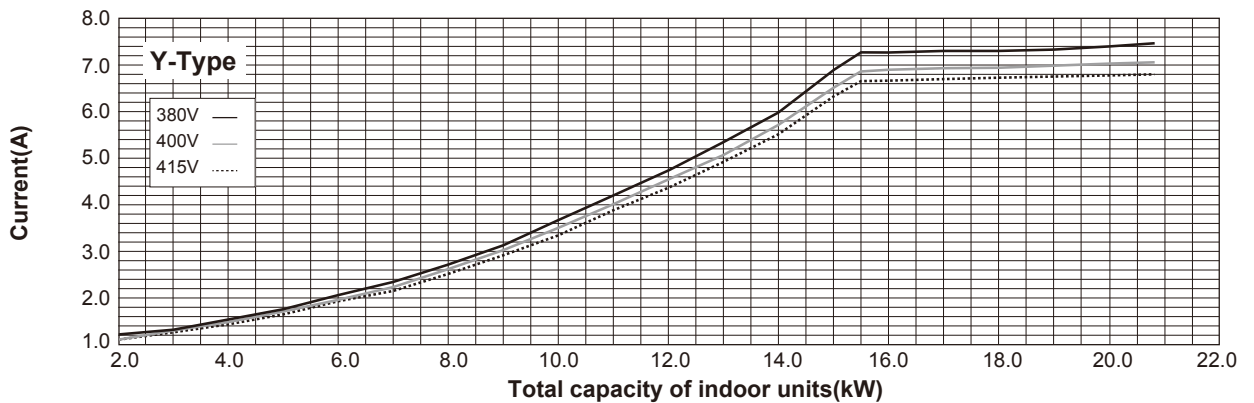
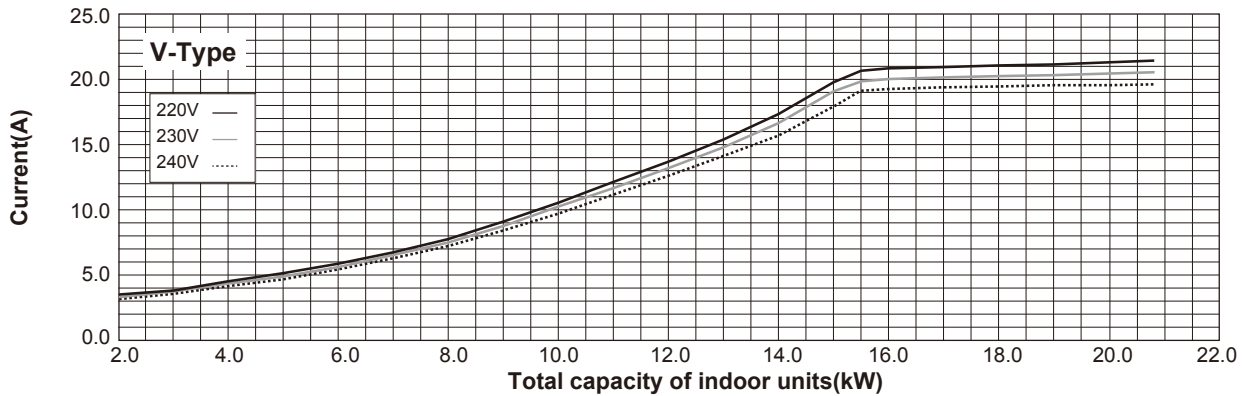
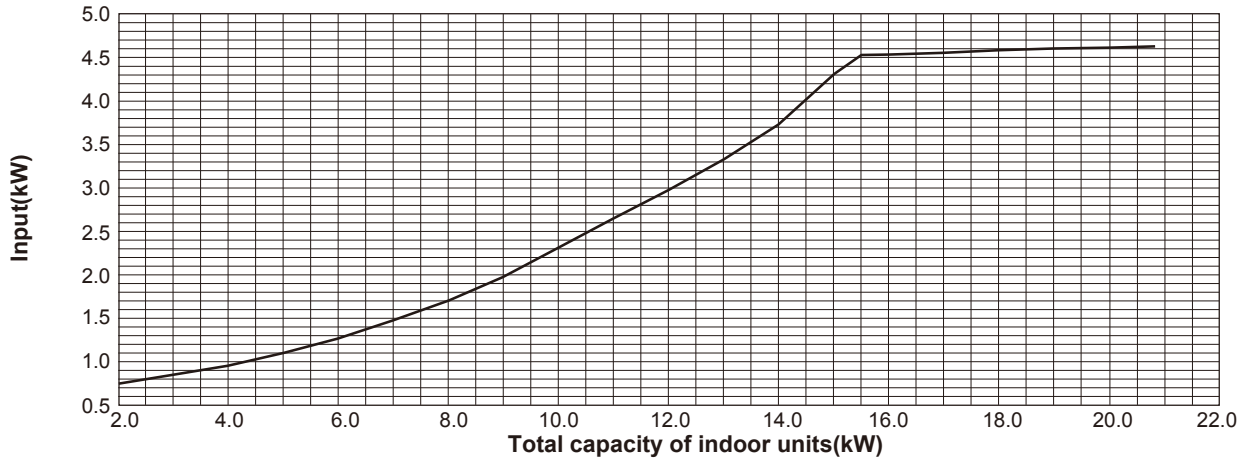
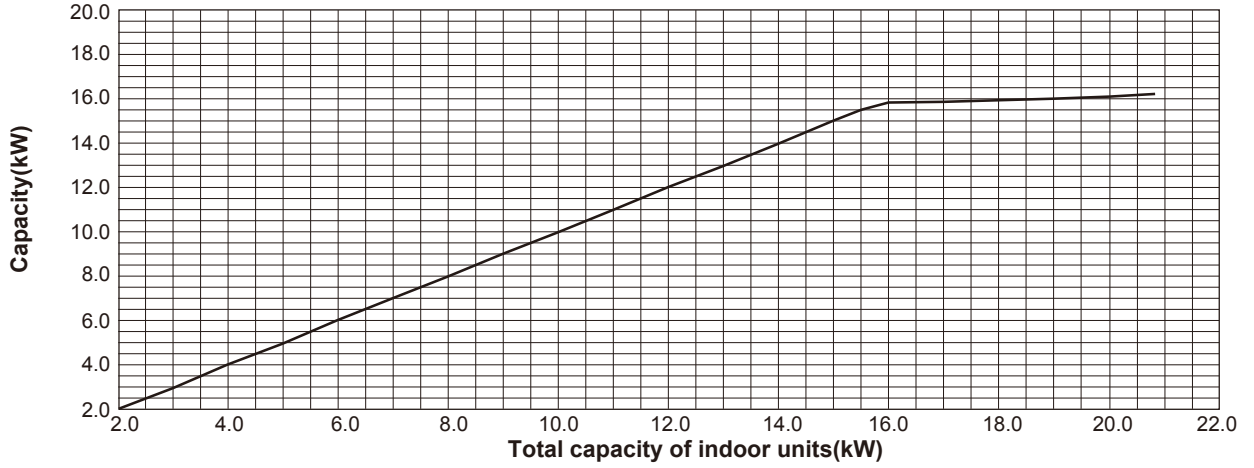

4-3-6. PUMY-P140VKM(-BS) PUMY-P140YKM(-BS) <heating>

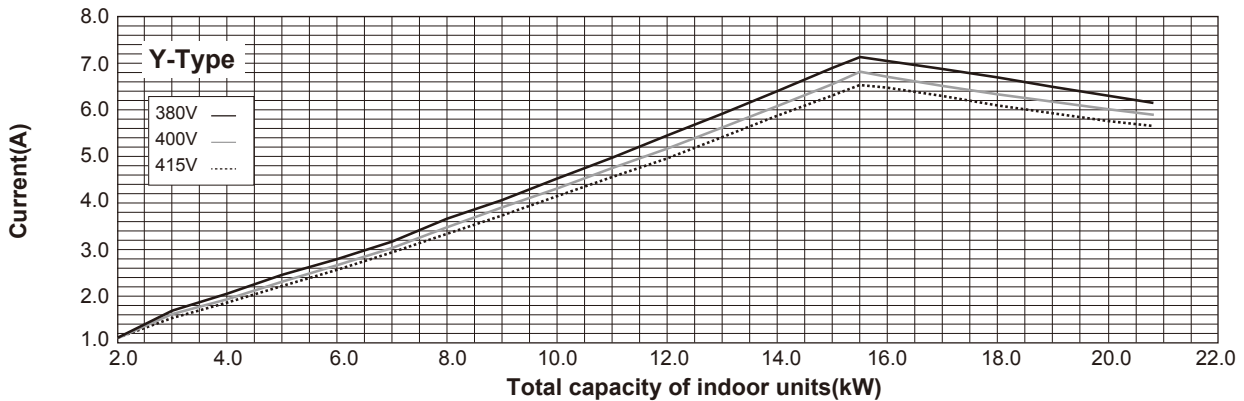
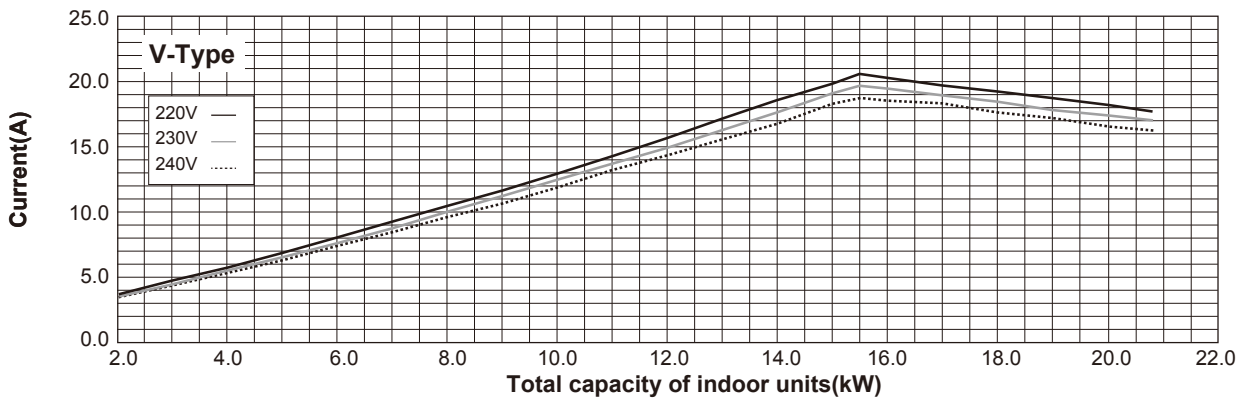
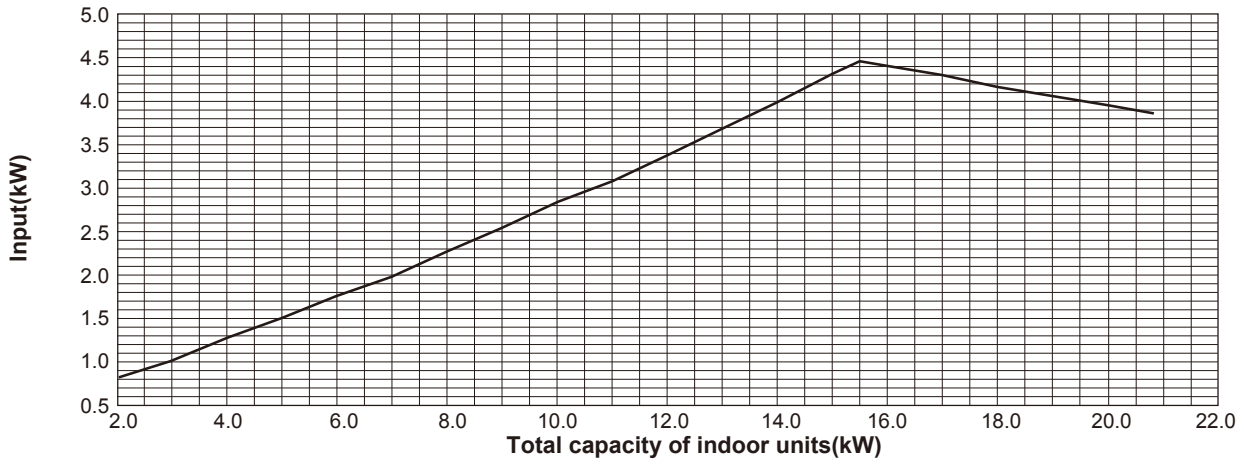
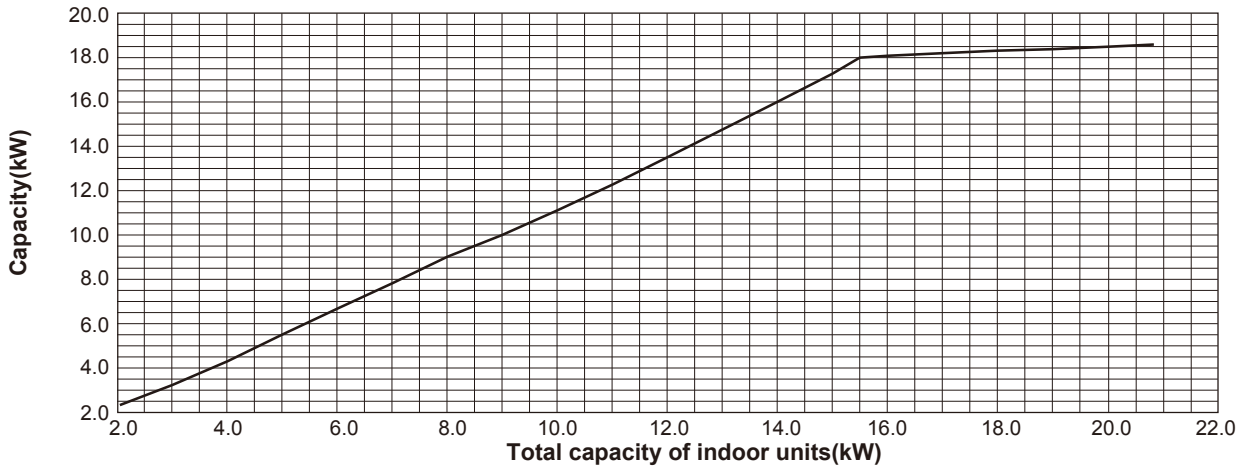

4-4. CORRECTING COOLING AND HEATING CAPACITY

4-4-1. Correcting Changes in Air Conditions

(1) The performance curve charts (Figure 1, 2) show the change ratio of capacity and input (power consumption) according to the indoor and outdoor temperature condition when defining the rated capacity (total capacity) and rated input under the standard condition in standard piping length (5 m) as "1.0".

• Standard conditions:

Rated cooling capacity	Indoor D.B. 27 °C / W.B. 19 °C Outdoor D.B. 35 °C
Rated heating capacity	Indoor D.B. 20 °C Outdoor D.B. 7 °C / W.B. 6 °C

• Use the rated capacity and rated input given in "4-3. Standard capacity diagram".

• The input is the single value on the side of the outdoor unit; the input on the sides of each indoor unit must be added to obtain the total input.

(2) The capacity of each indoor unit may be obtained by multiplying the total capacity obtained in (1) by the ratio between the individual capacity at the rated time and the total capacity at the rated time.

$$\text{Individual capacity under stated conditions} = \text{total capacity under the stated conditions} \times \frac{\text{individual capacity at the rated time}}{\text{total capacity at the rated time}}$$

(3) Capacity correction factor curve

PUMY-P112/125/140VKM(-BS)

PUMY-P112/125/140YKM(-BS)

Figure 1

Figure 2

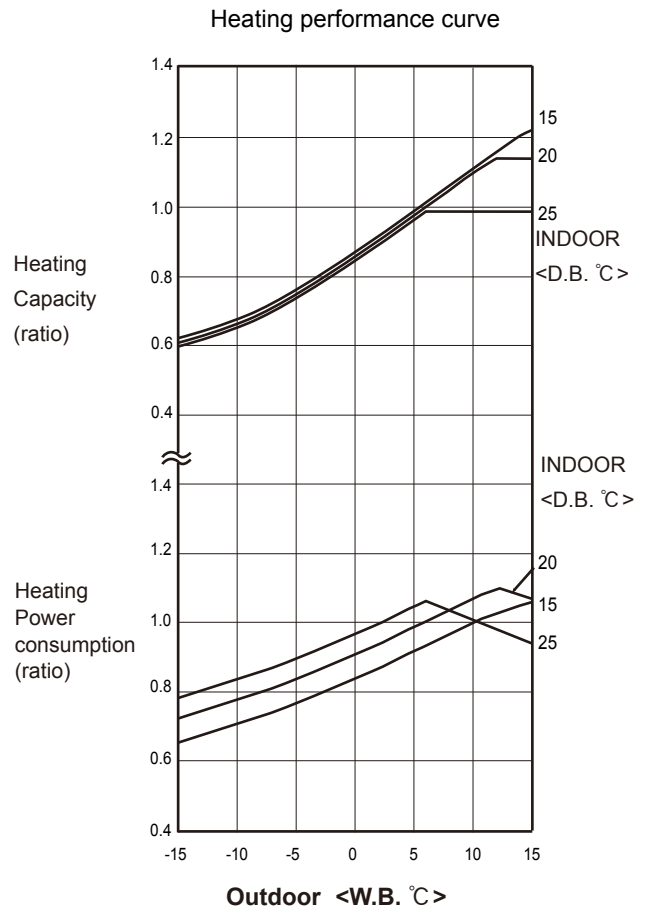
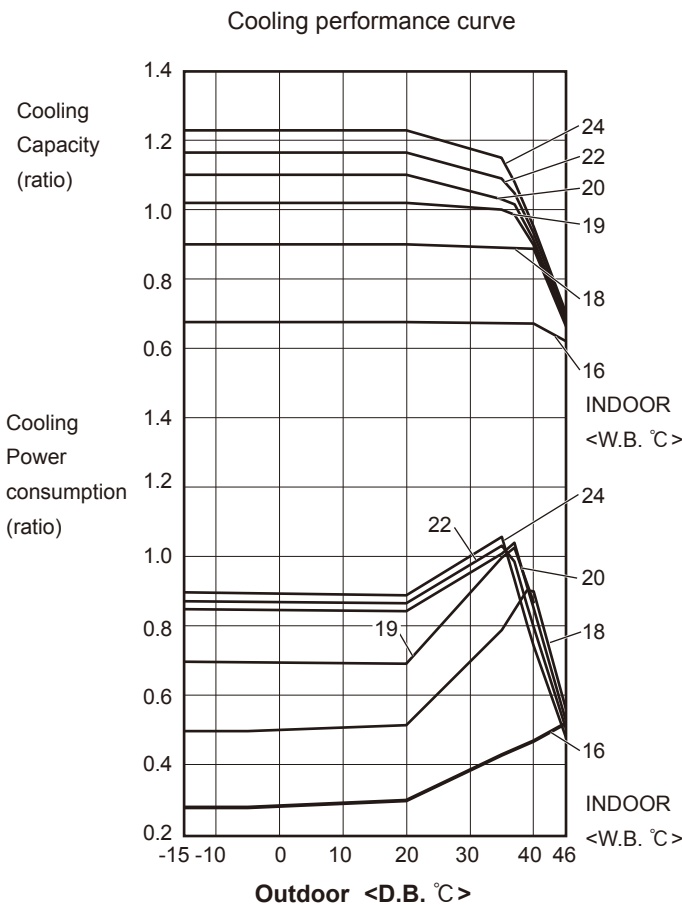

4-4-2. Correcting Capacity for Changes in the Length of Refrigerant Piping

- (1) During cooling, obtain the ratio (and the equivalent piping length) of the outdoor units rated capacity and the total in-use indoor capacity, and find the capacity ratio corresponding to the standard piping length from Figure 3. Then multiply by the cooling capacity from Figure 1 to obtain the actual capacity.
- (2) During heating, find the equivalent piping length, and find the capacity ratio corresponding to standard piping length from Figure 3. Then multiply by the heating capacity from Figure 2 to obtain the actual capacity.

(1) Capacity Correction Curve

Figure 3

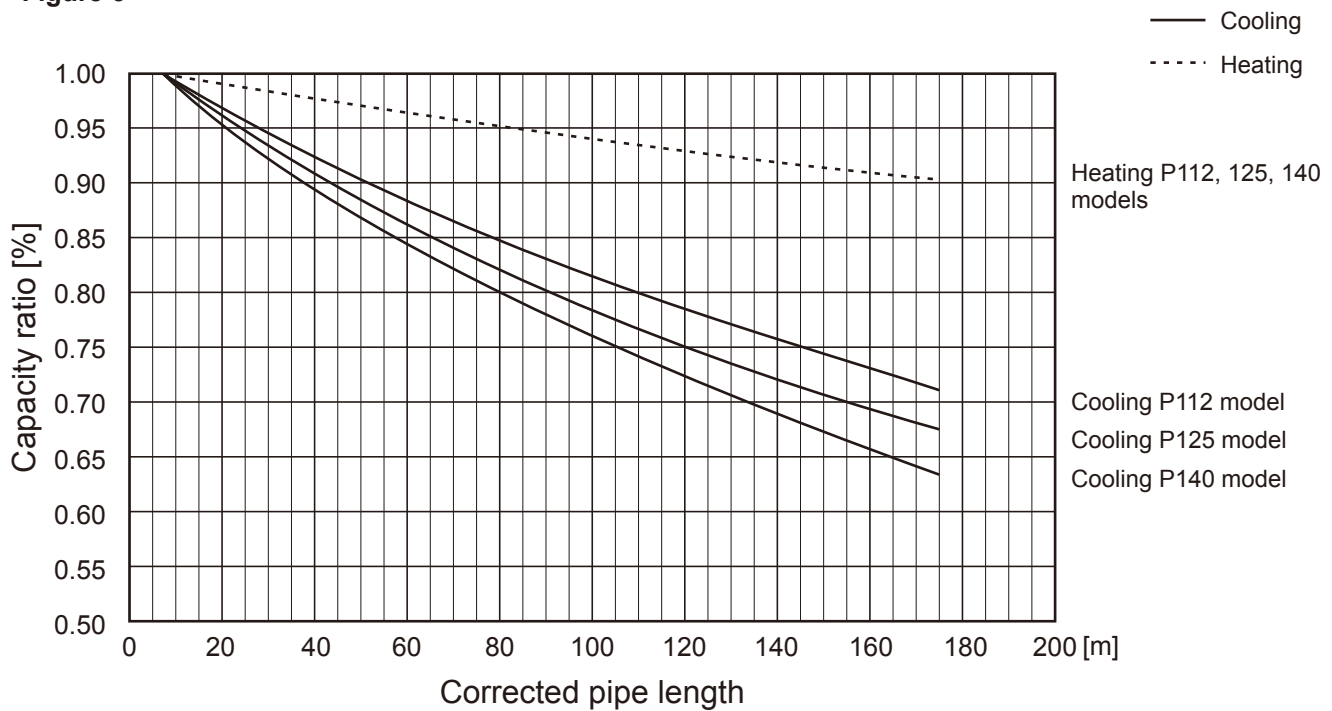

(2) Method for Obtaining the Equivalent Piping Length

Equivalent length for type P112-125-140 = (length of piping to farthest indoor unit) + (0.3 × number of bends in the piping) (m)

Length of piping to farthest indoor unit: type P112~P140.....150m

4-4-3. Correction of Heating Capacity for Frost and Defrosting

If heating capacity has been reduced due to frost formation or defrosting, multiply the capacity by the appropriate correction factor from the following table to obtain the actual heating capacity.

Correction factor diagram

Outdoor Intake temperature (W.B.°C)	6	4	2	0	-2	-4	-6	-8	-10	-15	-20
Correction factor	1.0	0.98	0.89	0.88	0.89	0.9	0.95	0.95	0.95	0.95	0.95

4-5. NOISE CRITERION CURVES

PUMY-P112VKM(-BS)
PUMY-P112YKM(-BS)

MODE	SPL(dB)	LINE
COOLING	49	○—○
HEATING	51	●—●

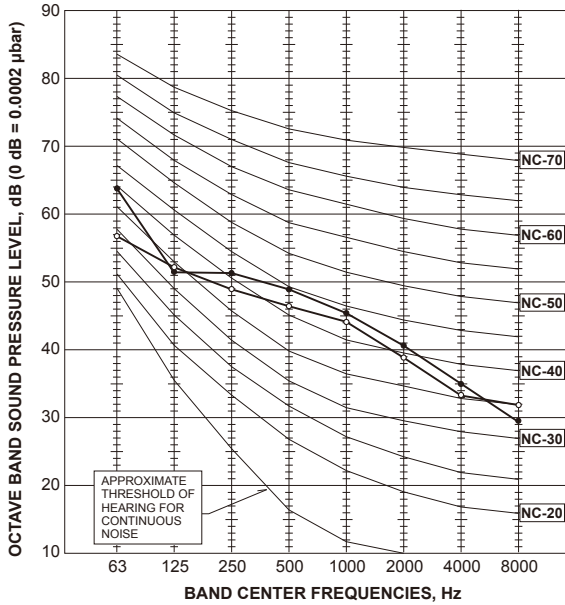

PUMY-P125VKM(-BS)
PUMY-P125YKM(-BS)

MODE	SPL(dB)	LINE
COOLING	50	○—○
HEATING	52	●—●

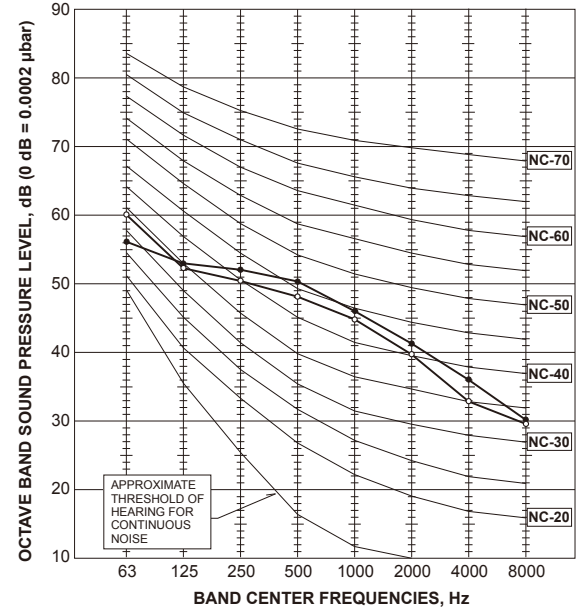

PUMY-P140VKM(-BS)
PUMY-P140YKM(-BS)

MODE	SPL(dB)	LINE
COOLING	51	○—○
HEATING	53	●—●

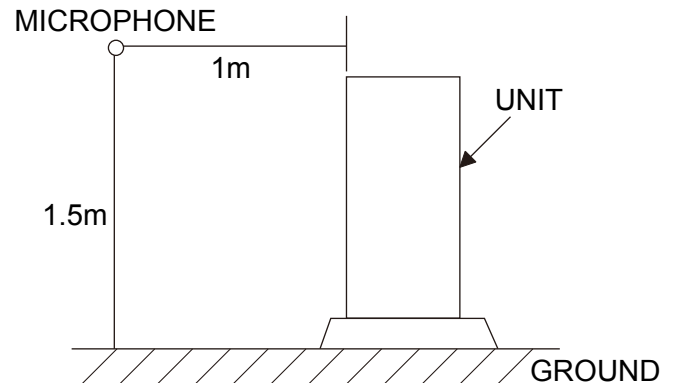
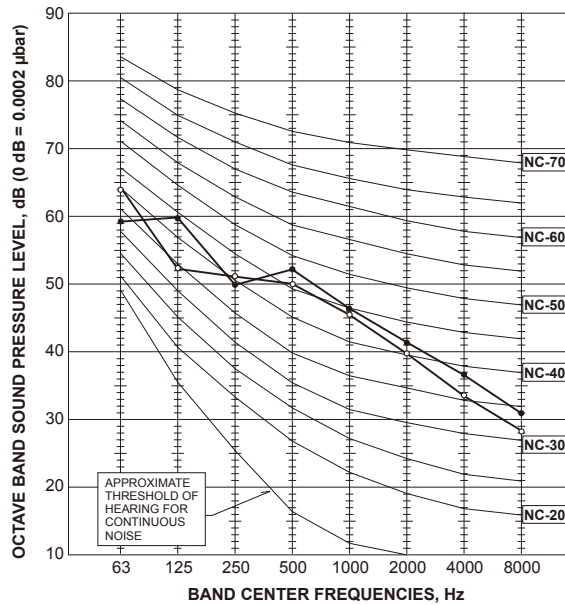

PUMY-P112VKM(-BS)
 PUMY-P125VKM(-BS)
 PUMY-P140VKM(-BS)

Unit : mm

1 FREE SPACE (Around the unit)
 The diagram below shows a basic example. Explanation of particular details are given in the installation manuals etc.

2 SERVICE SPACE
 Dimensions of space needed for service access are shown in the below diagram.

3 FOUNDATION BOLTS
 Please secure the unit firmly with 4 foundation (M10- ϕ (3/8)) bolts. (Bolts and washers must be purchased locally.)

4 PIPING-WIRING DIRECTIONS
 Piping and wiring connections can be made from 4 directions: FRONT, Right, Rear and Below.

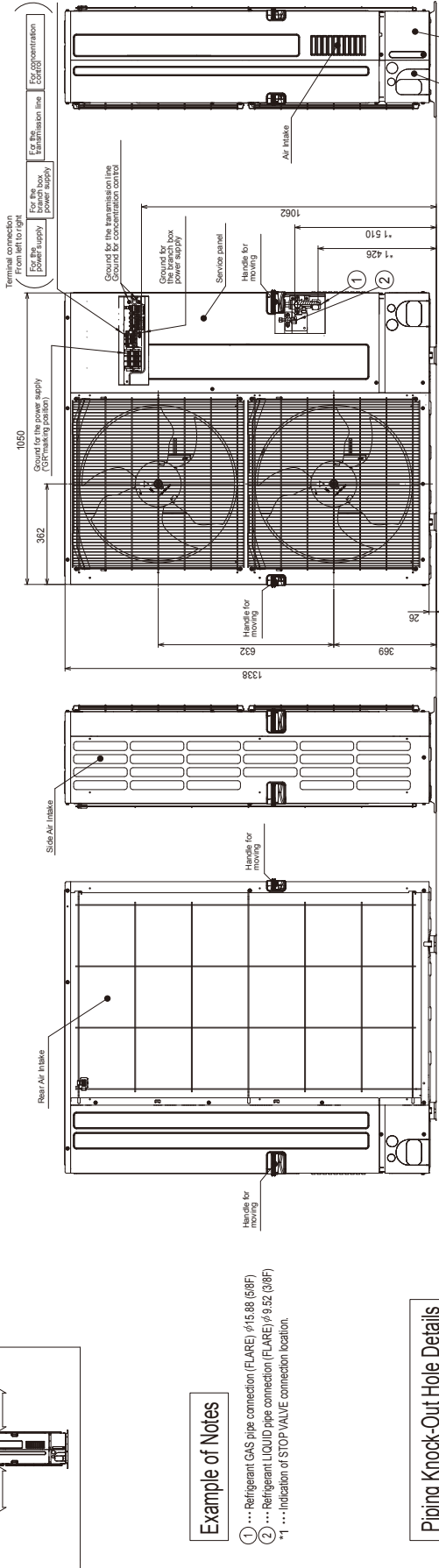
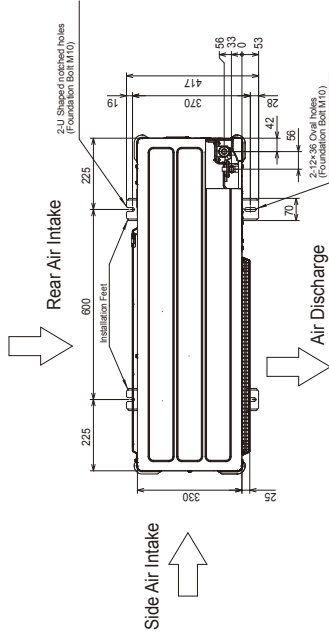

Example of Notes

- ① ... Refrigerant GAS pipe connection (FLARE) (φ15.88 (5/8"))
- ② ... Refrigerant LIQUID pipe connection (FLARE) (φ9.52 (3/8"))
- ① ... Indication of STOP VALVE connection location.

Piping Knock-Out Hole Details

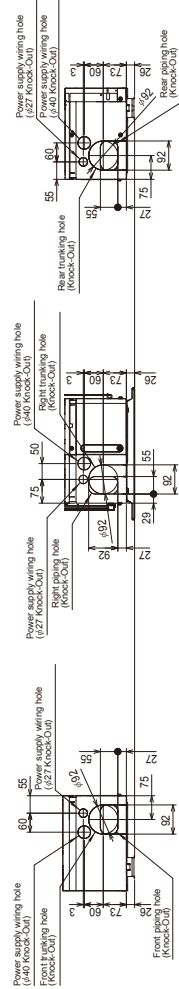

**PUMY-P112YKM(-BS)
PUMY-P125YKM(-BS)
PUMY-P140YKM(-BS)**

Unit : mm

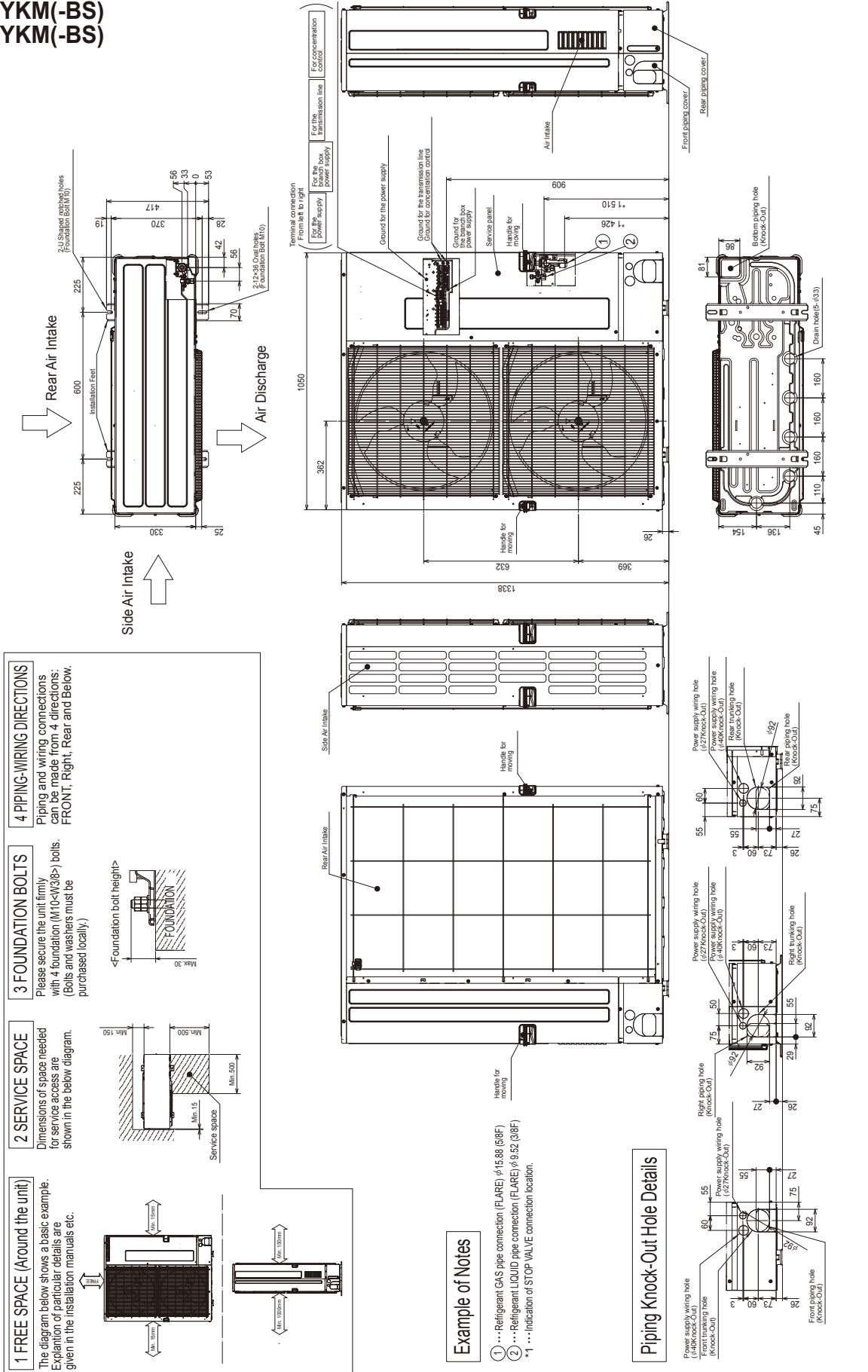

- 1 FREE SPACE (Around the unit)**
The diagram below shows a basic example. Explanation of particular details are given in the installation manuals etc.
- 2 SERVICE SPACE**
Dimensions of space needed for service access are shown in the below diagram.
- 3 FOUNDATION BOLTS**
Please secure the unit firmly with 4 foundation (M10×M3/8) bolts. (Bolts and washers must be purchased locally)
- 4 PIPING-WIRING DIRECTIONS**
Piping and wiring connections can be made from 4 directions: FRONT, Right, Rear and Below.

Example of Notes

- ① ... Refrigerant GAS pipe connection (FLARE) φ15.88 (5/8F)
- ② ... Refrigerant LIQUID pipe connection (FLARE) φ9.52 (3/8F)
- *1 ... Indication of STOP VALVE connection location.

Piping Knock-Out Hole Details

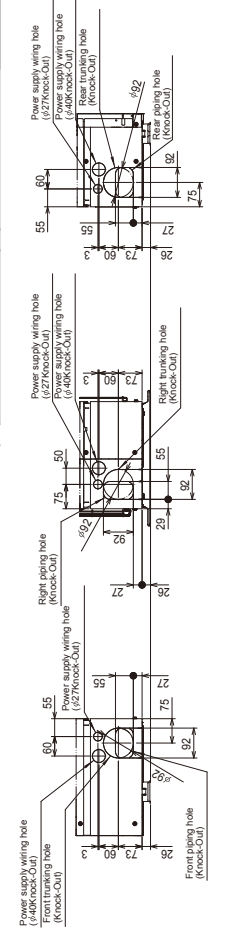

PUMY-P112VKM(-BS)

PUMY-P125VKM(-BS)

PUMY-P140VKM(-BS)

SYMBOL	NAME
TB1	Terminal Block <Power Supply>
TB1B	Terminal Block <Branch Box>
TB3	Terminal Block <Communication Line>
TB7	Terminal Block <Centralized Control Line>
FUSE1,FUSE2	Fuse <T20AL250V>
MC	Motor For Compressor
MF1,MF2	Fan Motor
21S4	Solenoid Valve <Four-Way Valve>
63H	High Pressure Switch
63HS	High Pressure Sensor
63LS	Low Pressure Sensor
SV1	Solenoid Valve <Bypass valve>
TH2	Thermistor <HiC Pipe>
TH3	Thermistor <Outdoor Liquid Pipe>
TH4	Thermistor <Compressor>
TH6	Thermistor <Suction Pipe>
TH7	Thermistor <Ambient>
TH8	Thermistor <Heat Sink>
LEV-A,LEV-B	Electronic Expansion Valve
DCL	Reactor
CB	Main Smoothing Capacitor
P.B.	Power Circuit Board
U/V/W	Connection Terminal <U/V/W-Phase>
LI	Connection Terminal <L-Phase>
NI	Connection Terminal <N-Phase>
N2	Connection Terminal <DC Voltage>
P2	Connection Terminal <DC Voltage>
DCL1,DCL2	Connection Terminal <Reactor>
IGBT	Power Module
E1,E2,E3,E4	Connection Terminal <Ground>
MULTI.B.	Controller Circuit Board
SW1	Switch <Display Selection>
SW2	Switch <Function Selection>
SW3	Switch <Test Run>
SW4	Switch <Model Selection>
SW5	Switch <Function Selection>
SW6	Switch <Function Selection>
SW7	Switch <Function Selection>
SW8	Switch <Model Selection>
SW9	Switch <Function Selection>
SWU1	Switch <Unit Address Selection, 1st digit>
SWU2	Switch <Unit Address Selection, 2nd digit>
CNS1	Connector <Indoor/Outdoor Transmission Line>
CNS2	Connector <Centralized Control Transmission Line>
SS	Connector <Connection For Option>
CN3D	Connector <Connection For Option>
CN3S	Connector <Connection For Option>
CN3N	Connector <Connection For Option>
CN51	Connector <Connection For Option>
LED1,LED2	LED <Operation Inspection Display>
LED3	LED <Power Supply to Main Microcomputer>
F1,F2	Fuse <T6,3AL250V>
X501~505	Relay
M-NET P.B.	M-NET Power Circuit Board
TB1	Connection Terminal <Ground>

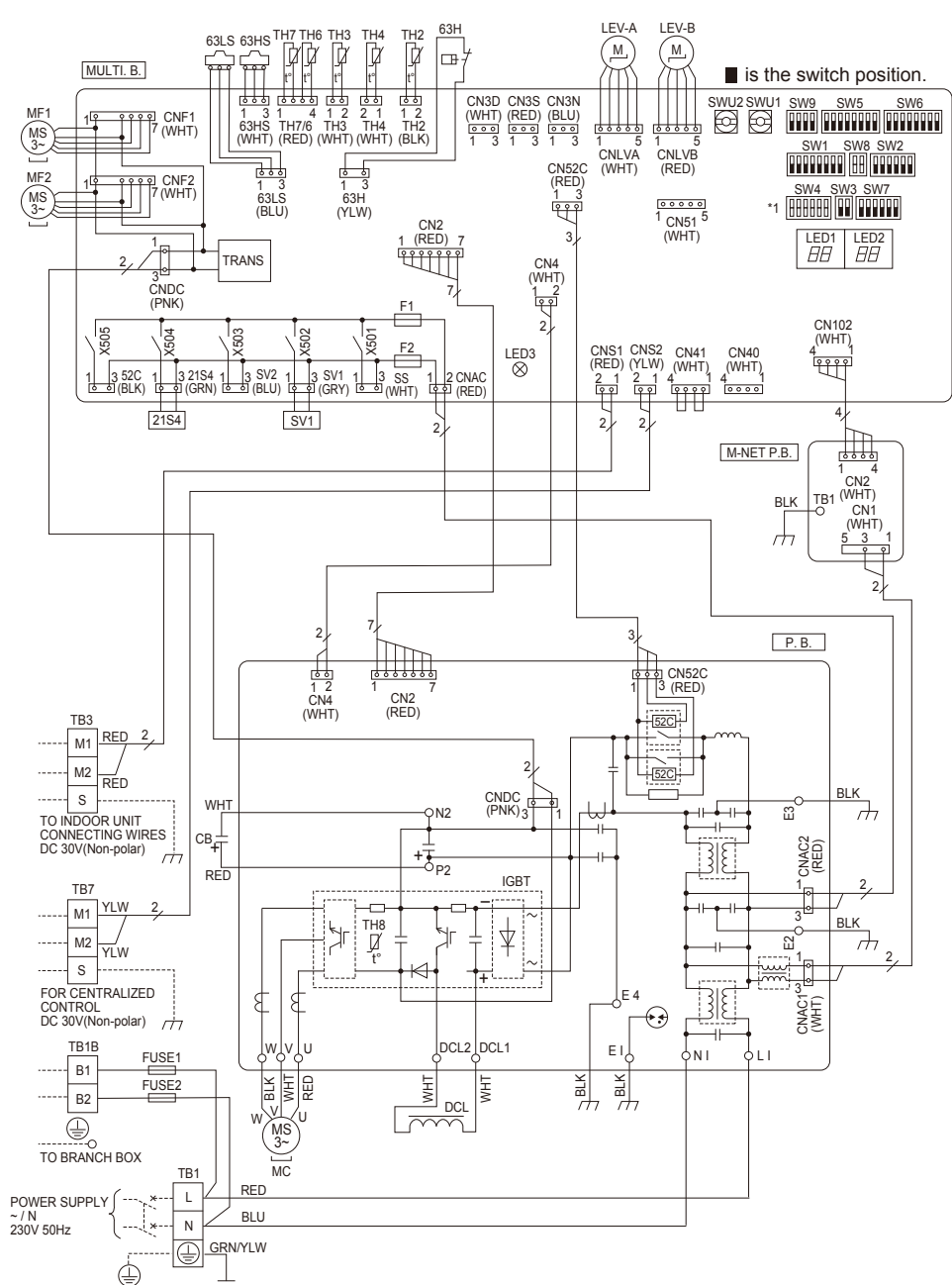

■ is the switch position.

Cautions when Servicing

- ⚠ **WARNING:** When the main supply is turned off, the voltage [340 V] in the main capacitor will drop to 20 V in approx. 2 minutes (input voltage: 230 V). When servicing, make sure that LED1, LED2 on the outdoor circuit board goes out, and then wait for at least 1 minute.
- Components other than the outdoor board may be faulty: Check and take corrective action, referring to the service manual. Do not replace the outdoor board without checking.

NOTES:

- Refer to the wiring diagrams of the indoor units for details on wiring of each indoor unit.
Self-diagnosis function
The indoor and outdoor units can be diagnosed automatically using the self-diagnosis switch (SW1) and LED1, LED2 (LED indication) found on the multi-controller of the outdoor unit.
LED indication : Set all contacts of SW1 to OFF.

- During normal operation
The LED indicates the drive state of the controller in the outdoor unit.

Bit	1	2	3	4	5	6	7	8
Indication	Compressor operated	52C	21S4	SV1	(SV2)	-	-	Always lit

- When fault requiring inspection has occurred
The LED alternately indicates the inspection code and the location of the unit in which the fault has occurred.

***1 MODEL SELECTION**
The black square (■) indicates a switch position.

MODELS	SW4	SW8
PUMY-P112VKM	ON OFF 1 2 3 4 5 6	ON OFF 1 2
PUMY-P125VKM	ON OFF 1 2 3 4 5 6	ON OFF 1 2
PUMY-P140VKM	ON OFF 1 2 3 4 5 6	ON OFF 1 2

[Example]
When the compressor and SV1 are turned during cooling operation.



PUMY-P112YKM(-BS)

PUMY-P125YKM(-BS)

PUMY-P140YKM(-BS)

SYMBOL	NAME
TB1	Terminal Block <Power Supply>
TB1B	Terminal Block <Branch Box>
TB3	Terminal Block <Communication Line>
TB7	Terminal Block <Centralized Control Line>
FUSE1,FUSE2	Fuse <T20AL250V>
MC	Motor For Compressor
MF1,MF2	Fan Motor
21S4	Solenoid Valve <Four-Way Valve>
63H	High Pressure Switch
63HS	High Pressure Sensor
63LS	Low Pressure Sensor
SV1	Solenoid Valve <Bypass valve>
TH2	Thermistor <Hic Pipe>
TH3	Thermistor <Outdoor Liquid Pipe>
TH4	Thermistor <Compressor>
TH6	Thermistor <Suction Pipe>
TH7	Thermistor <Ambient>
TH8	Thermistor <Heat Sink>
RS	Rush Current Protect Resistor
LEV-A,LEV-B	Electronic Expansion Valve
ACL4	Reactor
DCL	Reactor
P.B.	Power Circuit Board
TB-U/V/W	Connection Terminal <U/V/W-Phase>
TB-L1/L2/L3	Connection Terminal <L1/L2/L3-Power Supply>
TB-P1/P3	Connection Terminal
X52CA/B	52C Relay
N.F.	Noise Filter Circuit Board
L01/L02/L03	Connection Terminal <L1/L2/L3-Power Supply>
L1/L2/L3/N	Connection Terminal <L1/L2/L3-Power Supply>
GD1,GD3	Connection Terminal <Ground>
MULTI.B.	Controller Circuit Board
SW1	Switch <Display Selection>
SW2	Switch <Function Selection>
SW3	Switch <Test Run>
SW4	Switch <Model Selection>
SW5	Switch <Function Selection>
SW6	Switch <Function Selection>
SW7	Switch <Function Selection>
SW8	Switch <Model Selection>
SW9	Switch <Function Selection>
SWU1	Switch <Unit Address Selection, 1st digit>
SWU2	Switch <Unit Address Selection, 2nd digit>
CNS1	Connector <Indoor/Outdoor Transmission Line>
CNS2	Connector <Centralized Control Transmission Line>
SS	Connector <Connection For Option>
CN3D	Connector <Connection For Option>
CN3S	Connector <Connection For Option>
CN3N	Connector <Connection For Option>
CN51	Connector <Connection For Option>
LED1,LED2	LED <Operation Inspection Display>
LED3	LED <Power Supply to Main Microcomputer>
F1,F2	Fuse <T6,3AL250V>
X501-505	Relay
M-NET P.B.	M-NET Power Circuit Board
TB1	Connection Terminal <Ground>

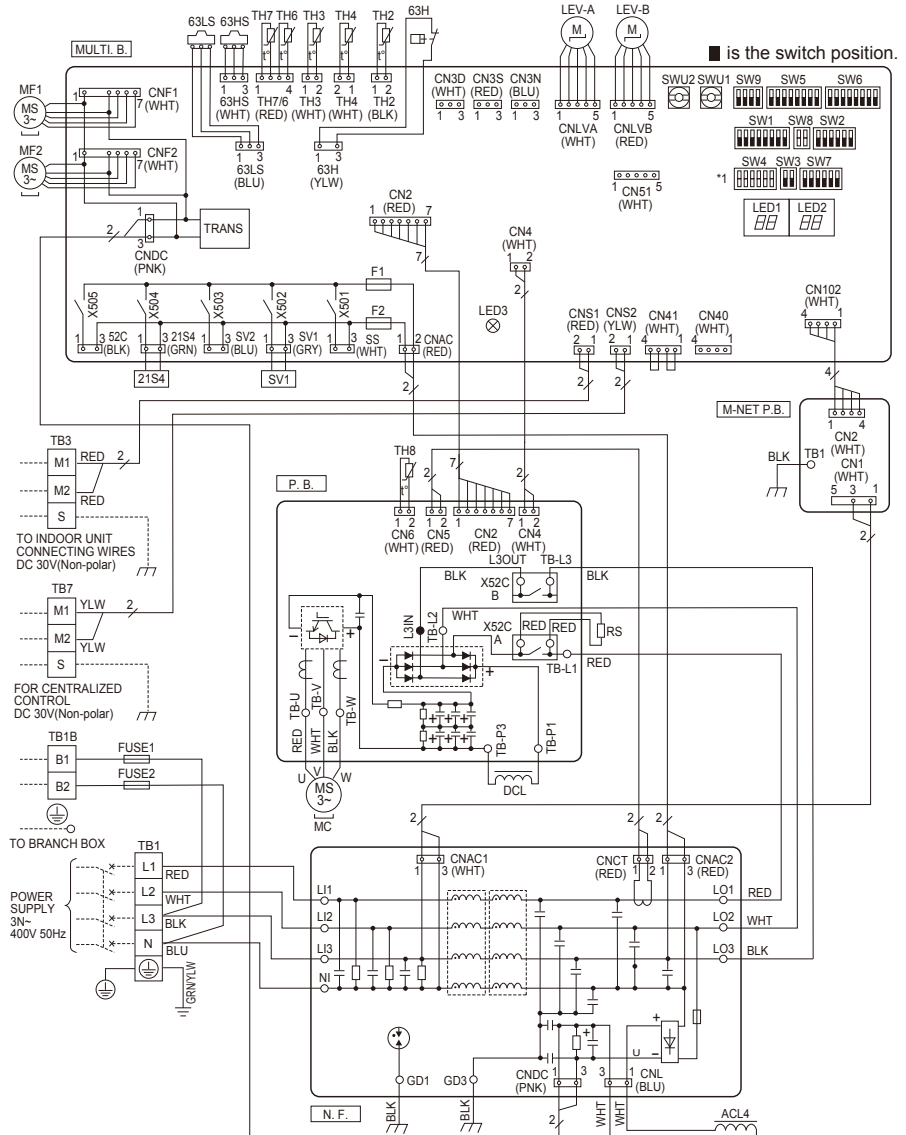

Cautions when Servicing

- **⚠ WARNING:** When the main supply is turned off, the voltage [570 V] in the main capacitor will drop to 20 V in approx. 5 minutes (input voltage: 400 V) . When servicing, make sure that LED1, LED2 on the outdoor circuit board goes out, and then wait for at least 5 minute.
- Components other than the outdoor board may be faulty: Check and take corrective action, referring to the service manual. Do not replace the outdoor board without checking.

NOTES:

1. Refer to the wiring diagrams of the indoor units for details on wiring of each indoor unit.
Self-diagnosis function
The indoor and outdoor units can be diagnosed automatically using the self-diagnosis switch (SW1) and LED1, LED2 (LED indication) found on the multi-controller of the outdoor unit.
LED indication : Set all contacts of SW1 to OFF.
2. During normal operation
The LED indicates the drive state of the controller in the outdoor unit.

Bit	1	2	3	4	5	6	7	8
Indication	Compressor operated	52C	21S4	SV1	(SV2)	—	—	Always lit

3. When fault requiring inspection has occurred
The LED alternately indicates the inspection code and the location of the unit in which the fault has occurred.

***1 MODEL SELECTION**
The black square (■) indicates a switch position.

MODELS	SW4	SW8
PUMY-P112YKM	ON OFF 1 2 3 4 5 6	ON OFF 1 2
PUMY-P125YKM	ON OFF 1 2 3 4 5 6	ON OFF 1 2
PUMY-P140YKM	ON OFF 1 2 3 4 5 6	ON OFF 1 2

[Example]
When the compressor and SV1 are turned during cooling operation.

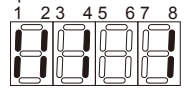

7-1. TRANSMISSION SYSTEM SETUP

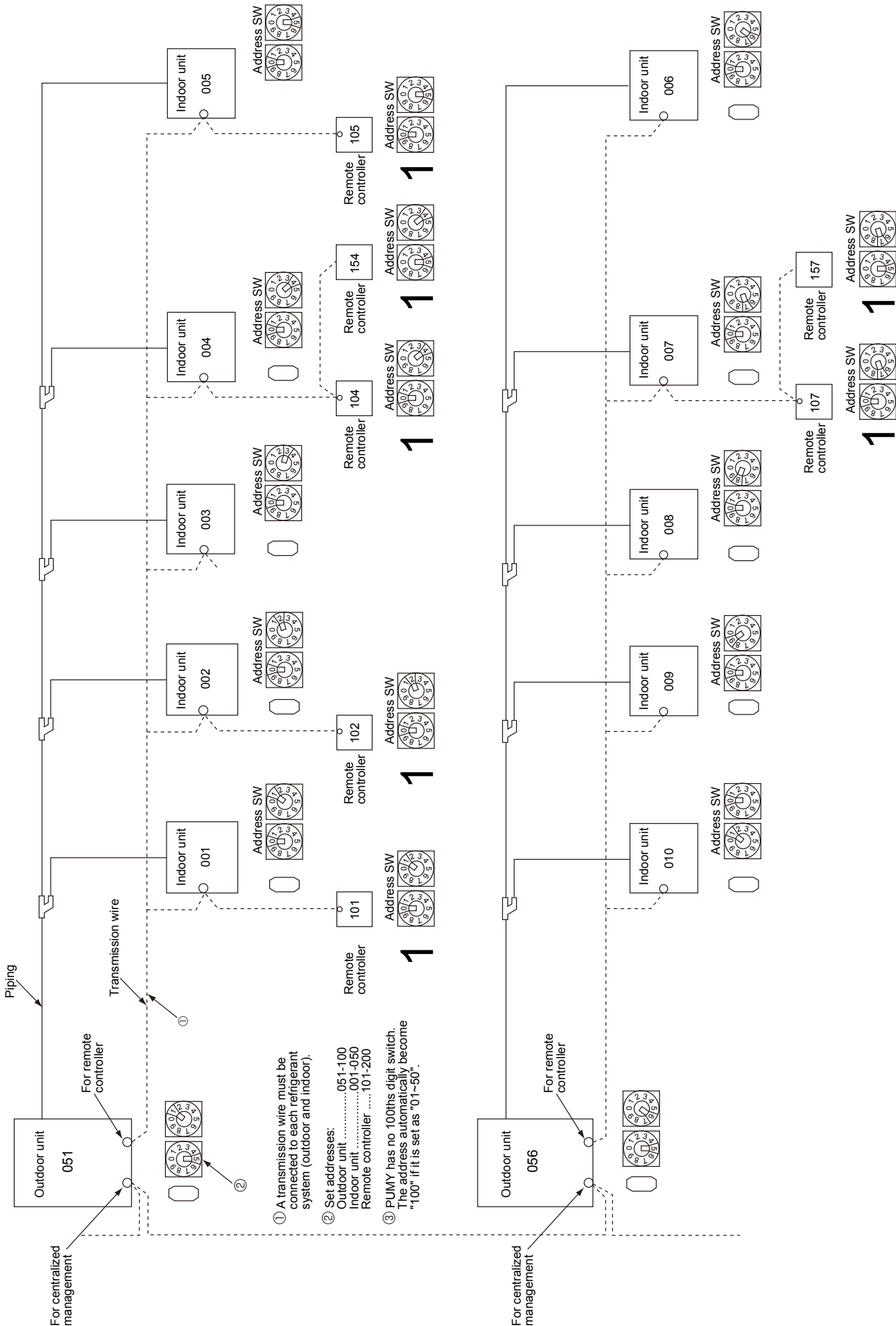

7-2. REFRIGERANT SYSTEM DIAGRAM

PUMY-P112VKM(-BS) **PUMY-P112YKM(-BS)**
PUMY-P125VKM(-BS) **PUMY-P125YKM(-BS)**
PUMY-P140VMK(-BS) **PUMY-P140YMK(-BS)**

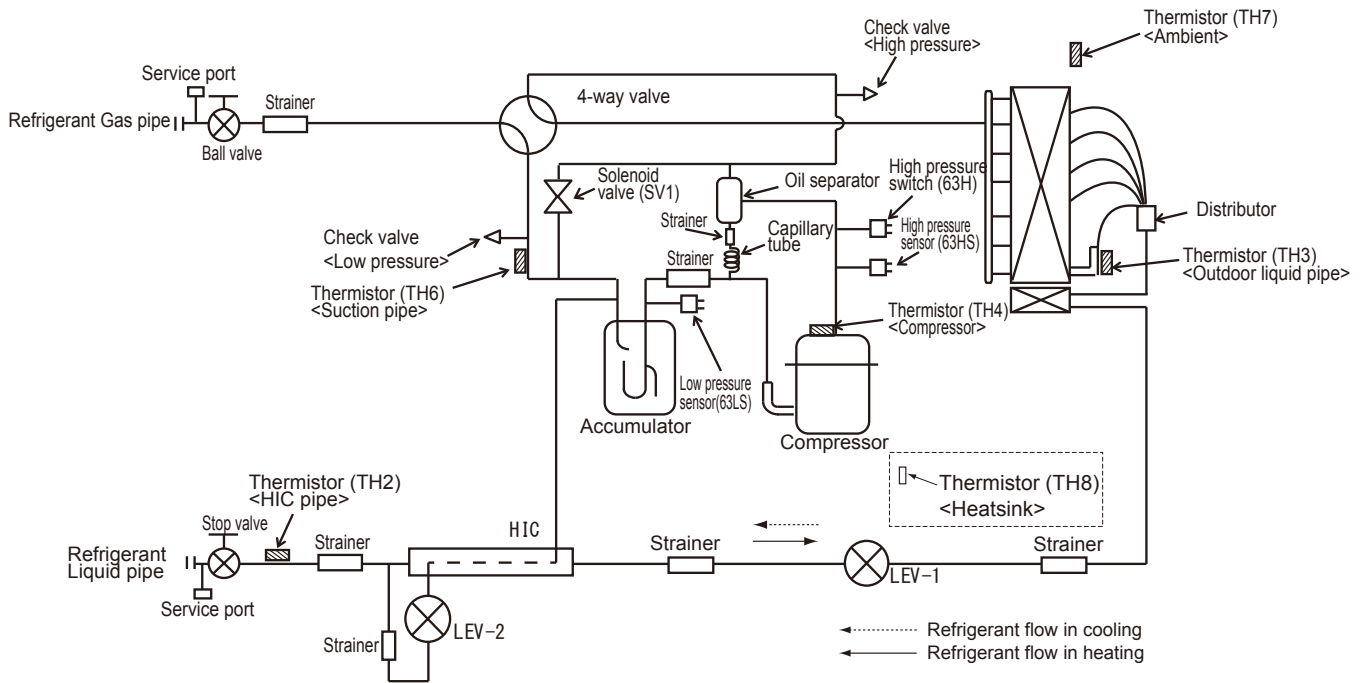

Capillary tube for oil separator : $\phi 2.5 \times \phi 0.8 \times L1000$

Refrigerant piping specifications <dimensions of flared connector>

Unit: mm <inch>

Capacity	Item	Liquid piping	Gas piping
Indoor unit	P15, P20, P25, P32, P40, P50	$\phi 6.35$ <1/4>	$\phi 12.7$ <1/2>
	P63, P80, P100 P125, P140	$\phi 9.52$ <3/8>	$\phi 15.88$ <5/8>
Outdoor unit	P112, P125, P140	$\phi 9.52$ <3/8>	$\phi 15.88$ <5/8>

Note:

When connecting the CONNECTION KIT (PAC-LV11M-J) and an M-series indoor unit, refer to the installation manual for the CONNECTION KIT.

7-3. SYSTEM CONTROL

7-3-1. Example for the System

- Example for wiring control cables, wiring method and address setting, permissible lengths, and the prohibited items are listed in the standard system with detailed explanation.

The explanation for the system in this section : Use 1 single outdoor unit and multiple outdoor units for M-NET remote control system.

Use 1 single outdoor unit and multiple indoor units in the multiple outdoor units for the M-NET remote control system.

A. Example of a M-NET remote controller system (address setting is necessary.)

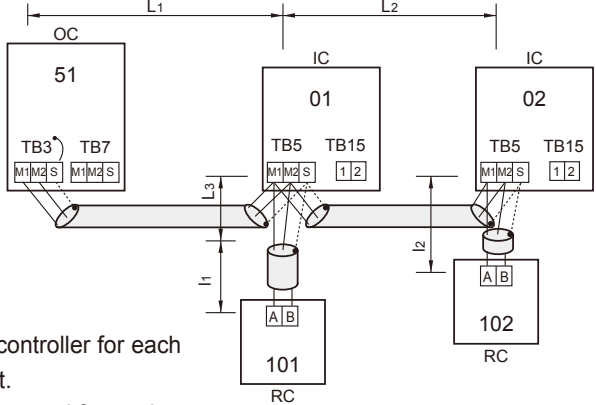
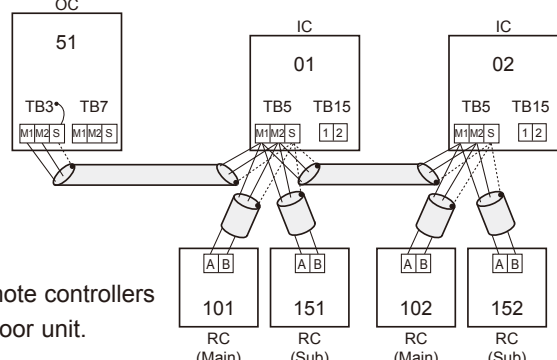
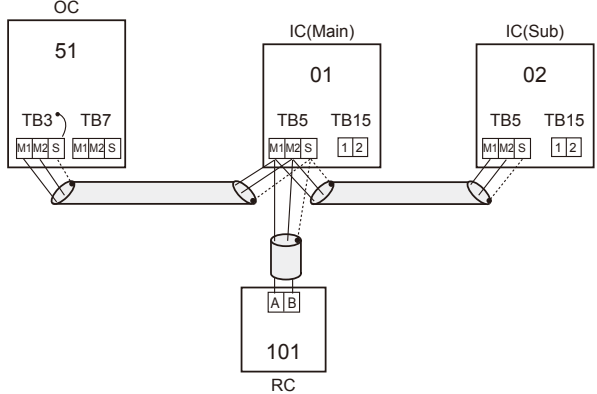
Example of wiring control cables	Wiring Method and Address Setting																				
<p>1. Standard operation</p>  <ul style="list-style-type: none"> • 1 remote controller for each indoor unit. • There is no need for setting the 100 position on the remote controller. 	<p>a. Use feed wiring to connect terminals M1 and M2 on transmission cable block (TB3) for the outdoor unit (OC) to terminals M1 and M2 on the transmission cable block (TB5) of each indoor unit (IC). Use non-polarized 2 wire.</p> <p>b. Connect terminals M1 and M2 on transmission cable terminal block (TB5) for each indoor unit with the terminal block (TB6) for the remote controller (RC).</p> <p>c. Set the address setting switch (on outdoor unit P.C.B) as shown below.</p> <table border="1" data-bbox="836 862 1444 1077"> <thead> <tr> <th>Unit</th> <th>Range</th> <th>Setting Method</th> </tr> </thead> <tbody> <tr> <td>Indoor unit (IC)</td> <td>001 to 050</td> <td>—</td> </tr> <tr> <td>Outdoor unit (OC)</td> <td>051 to 100</td> <td>Use the smallest address of all the indoor unit plus 50.</td> </tr> <tr> <td>Remote controller (RC)</td> <td>101 to 150</td> <td>Indoor unit address plus 100.</td> </tr> </tbody> </table>			Unit	Range	Setting Method	Indoor unit (IC)	001 to 050	—	Outdoor unit (OC)	051 to 100	Use the smallest address of all the indoor unit plus 50.	Remote controller (RC)	101 to 150	Indoor unit address plus 100.						
Unit	Range	Setting Method																			
Indoor unit (IC)	001 to 050	—																			
Outdoor unit (OC)	051 to 100	Use the smallest address of all the indoor unit plus 50.																			
Remote controller (RC)	101 to 150	Indoor unit address plus 100.																			
<p>2. Operation using 2 remote controllers</p>  <ul style="list-style-type: none"> • Using 2 remote controllers for each indoor unit. 	<p>a. Same as above.</p> <p>b. Same as above.</p> <p>c. Set address switch (on outdoor unit P.C.B) as shown below.</p> <table border="1" data-bbox="836 1198 1444 1496"> <thead> <tr> <th>Unit</th> <th>Range</th> <th>Setting Method</th> </tr> </thead> <tbody> <tr> <td>Indoor Unit (IC)</td> <td>001 to 050</td> <td>—</td> </tr> <tr> <td>Outdoor unit (OC)</td> <td>051 to 100</td> <td>Use the smallest address of all the indoor units plus 50.</td> </tr> <tr> <td>Main Remote Controller (RC)</td> <td>101 to 150</td> <td>Indoor unit address plus 100.</td> </tr> <tr> <td>Sub Remote Controller (RC)</td> <td>151 to 200</td> <td>Indoor unit address plus 150.</td> </tr> </tbody> </table>			Unit	Range	Setting Method	Indoor Unit (IC)	001 to 050	—	Outdoor unit (OC)	051 to 100	Use the smallest address of all the indoor units plus 50.	Main Remote Controller (RC)	101 to 150	Indoor unit address plus 100.	Sub Remote Controller (RC)	151 to 200	Indoor unit address plus 150.			
Unit	Range	Setting Method																			
Indoor Unit (IC)	001 to 050	—																			
Outdoor unit (OC)	051 to 100	Use the smallest address of all the indoor units plus 50.																			
Main Remote Controller (RC)	101 to 150	Indoor unit address plus 100.																			
Sub Remote Controller (RC)	151 to 200	Indoor unit address plus 150.																			
<p>3. Group operation</p>  <ul style="list-style-type: none"> • Multiple indoor units operated together by 1 remote controller 	<p>a. Same as above.</p> <p>b. Connect terminals M1 and M2 on transmission cable terminal block (TB5) of the IC main unit with the most recent address within the same indoor unit (IC) group to terminal block (TB6) on the remote controller.</p> <p>c. Set the address setting switch (on outdoor unit P.C.B) as shown below.</p> <table border="1" data-bbox="836 1691 1444 2004"> <thead> <tr> <th>Unit</th> <th>Range</th> <th>Setting Method</th> </tr> </thead> <tbody> <tr> <td>IC (Main)</td> <td>001 to 050</td> <td>Use the smallest address within the same group of indoor units.</td> </tr> <tr> <td>IC (Sub)</td> <td>001 to 050</td> <td>Use an address, other than that of the IC (Main) from among the units within the same group of indoor units. This must be in sequence with the IC (Main).</td> </tr> <tr> <td>Outdoor Unit</td> <td>051 to 100</td> <td>Use the smallest address of all the indoor units plus 50.</td> </tr> <tr> <td>Main Remote Controller</td> <td>101 to 150</td> <td>Set at an IC (Main) address within the same group plus 100.</td> </tr> <tr> <td>Sub Remote Controller</td> <td>151 to 200</td> <td>Set at an IC (Main) address within the same group plus 150.</td> </tr> </tbody> </table> <p>d. Use the indoor unit (IC) within the group with the most functions as the IC (Main) unit.</p>			Unit	Range	Setting Method	IC (Main)	001 to 050	Use the smallest address within the same group of indoor units.	IC (Sub)	001 to 050	Use an address, other than that of the IC (Main) from among the units within the same group of indoor units. This must be in sequence with the IC (Main).	Outdoor Unit	051 to 100	Use the smallest address of all the indoor units plus 50.	Main Remote Controller	101 to 150	Set at an IC (Main) address within the same group plus 100.	Sub Remote Controller	151 to 200	Set at an IC (Main) address within the same group plus 150.
Unit	Range	Setting Method																			
IC (Main)	001 to 050	Use the smallest address within the same group of indoor units.																			
IC (Sub)	001 to 050	Use an address, other than that of the IC (Main) from among the units within the same group of indoor units. This must be in sequence with the IC (Main).																			
Outdoor Unit	051 to 100	Use the smallest address of all the indoor units plus 50.																			
Main Remote Controller	101 to 150	Set at an IC (Main) address within the same group plus 100.																			
Sub Remote Controller	151 to 200	Set at an IC (Main) address within the same group plus 150.																			
Combinations of 1 through 3 above are possible.																					

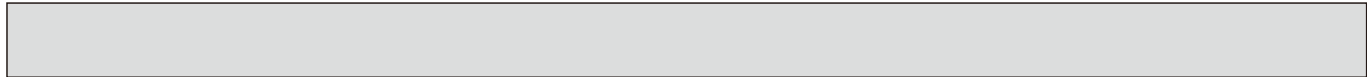

• Name, Symbol and the Maximum Remote controller Units for Connection

Name	Symbol	Maximum units for connection
Outdoor unit	OC	—
Indoor unit	IC	1 OC unit can be connected to 1~9 (P112)/1~10 (P125)/1~12 (P140) IC units
M-NET remote controller	RC	Maximum 2 RC for 1 indoor unit, Maximum 12 RC for 1 OC

Permissible Lengths	Prohibited items
<p>Longest transmission cable length (1.25 mm²) $L_1 + L_2, L_2 + L_3, L_3 + L_1 \leq 200\text{m}$ Remote controller cable length 1. If 0.5 to 1.25 mm² $l_1, l_2 \leq 10\text{m}$ 2. If the length exceeds 10 meters, the exceeding section should be 1.25 mm² and that section should be a value within the total extension length of the transmission cable and maximum transmission cable length. (L3)</p>	<ul style="list-style-type: none"> M-NET remote controller (RC) and MA remote controller (MA) cannot be used together. Do not connect anything with TB15 of indoor unit (IC).
Same as above	<ul style="list-style-type: none"> Use the indoor unit (IC) address plus 150 as the sub remote controller address. In this case, it should be 152. 3 or more remote controller (RC) cannot be connected to 1 indoor unit.
Same as above	<ul style="list-style-type: none"> The remote controller address is the indoor unit main address plus 100. In this case, it should be 101.

B. Example of a group operation system with 2 or more outdoor units and a M-NET remote controller.
(Address settings are necessary.)

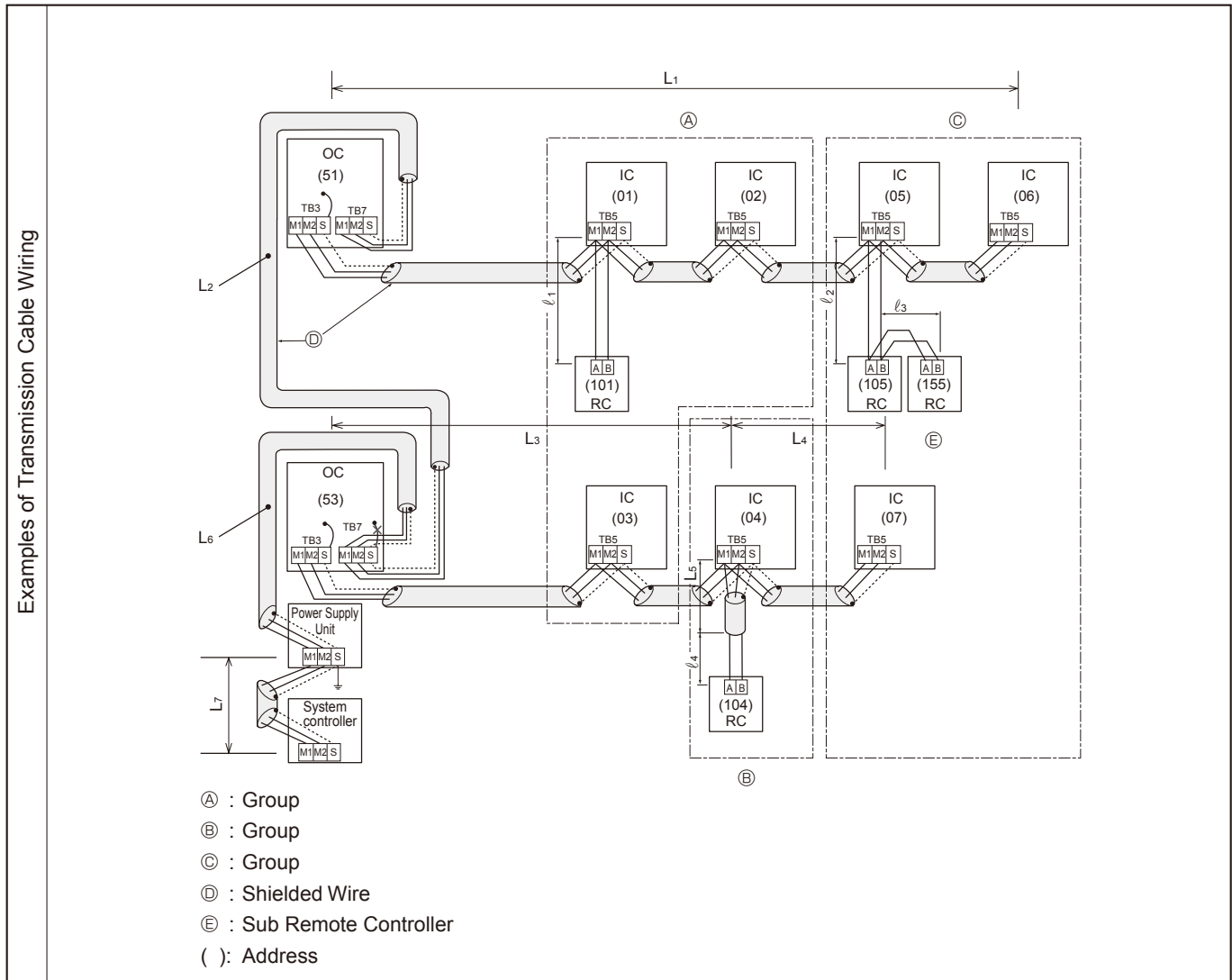

- Wiring Method Address Settings
- Always use shielded wire when making connections between the outdoor unit (OC) and the indoor unit (IC), as well for all OC-OC, and IC-IC wiring intervals.
 - Use feed wiring to connect terminals M1 and M2 and the ground terminal on the transmission cable terminal block (TB3) of each outdoor unit (OC) to terminals M1 and M2 on the terminal S on the transmission cable block of the indoor unit (IC).
 - Connect terminals M1 and M2 on the transmission cable terminal block of the indoor unit (IC) that has the most recent address within the same group to the terminal block on the remote controller (RC).
 - Connect together terminals M1, M2 and terminal S on the terminal block for centralized control (TB7) for the outdoor unit (OC).
 - DO NOT change the jumper connector CN41 on MULTI controller board.
 - The earth processing of S terminal for the centralized control terminal block (TB7) is unnecessary. Connect the terminal S on the power supply unit with the earth.
 - Set the address setting switch as follows.

Unit	Range	Setting Method
IC (Main)	01 to 00	Use the smallest address within the same group of indoor units.
IC (Sub)	01 to 50	Use an address, other than the IC (Main) in the same group of indoor units. This must be in sequence with the IC (Main).
Outdoor Unit	51 to 100	Use the smallest address of all the indoor units plus 50. The address automatically becomes "100" if it is set as "01 - 50".
Main Remote Controller	101 to 150	Set at an IC (Main) address within the same group plus 100.
Sub Remote Controller	151 to 200	Set at an IC (Main) address within the same group plus 150.
MA Remote Controller	—	Unnecessary address setting (Necessary main/ sub setting)

h. The group setting operations among the multiple indoor units is done by the remote controller (RC) after the electrical power has been turned on.

• Name, Symbol, and the Maximum Units for Connection

Permissible Length

- Longest length via outdoor units : $L_1+L_2+L_3+L_4, L_1+L_2+L_3+L_5, L_1+L_2+L_6+L_7 \leq 500$ meters (1.25mm²)
- Longest transmission cable length : $L_1, L_3+L_4, L_3+L_5, L_6, L_2+L_6, L_7 \leq 200$ meters (1.25mm²)
- Remote controller cable length : $l_1, l_2, l_2+l_3, l_4 \leq 10$ meters (0.5 to 1.25mm²)

If the length exceeds 10 meters, use a 1.25 mm² shielded wire. The length of this section (L₈) should be included in the calculation of the maximum length and overall length.

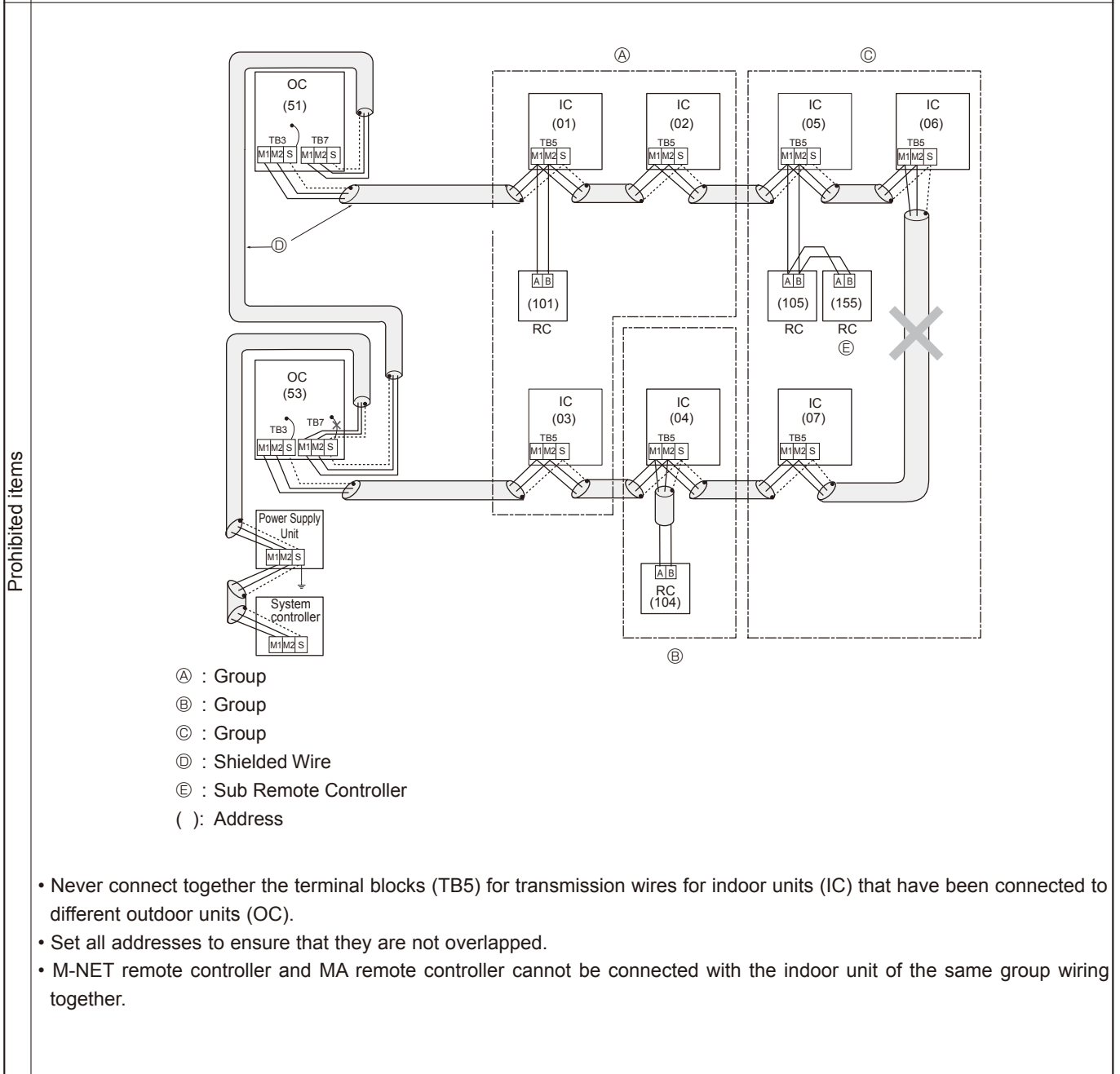

C. Example of a MA remote controller system (address setting is not necessary.)

NOTE : In the case of same group operation, need to set the address that is only main indoor unit.

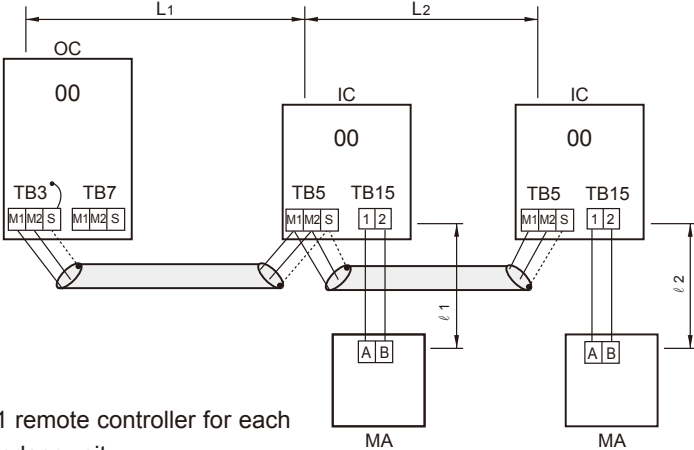
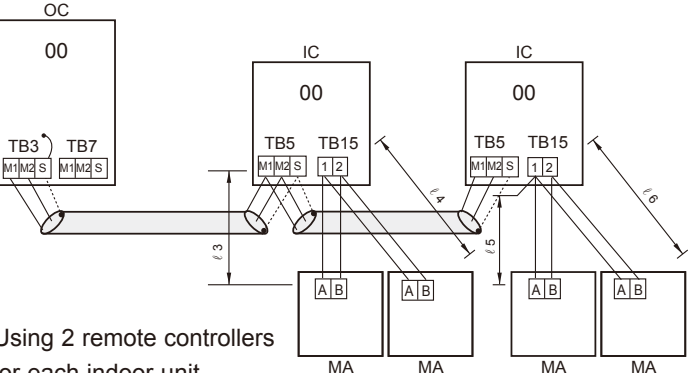
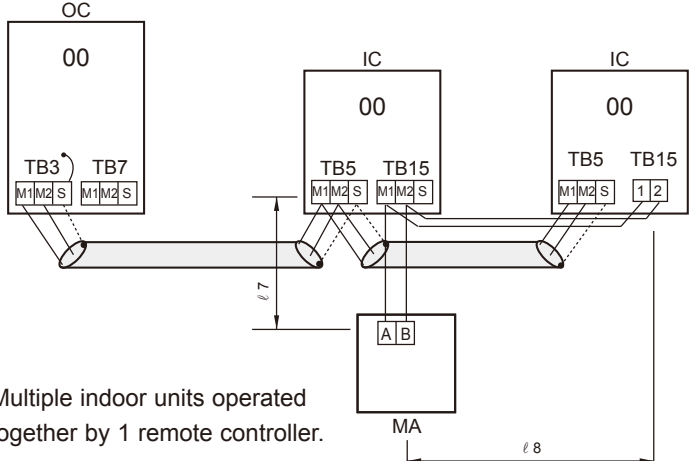
Example of wiring control cables	Wiring Method and Address Setting
<p>1. Standard operation</p>  <p>• 1 remote controller for each indoor unit.</p>	<p>a. Use feed wiring to connect terminals M1 and M2 on transmission cable block (TB3) for the outdoor unit (OC) to terminals M1 and M2 on the transmission cable block (TB5) of each indoor unit (IC). Use non-polarized 2 wire.</p> <p>b. Connect terminals 1 and 2 on transmission cable terminal block (TB15) for each indoor unit with the terminal block for the MA remote controller (MA).</p>
<p>2. Operation using two remote controllers</p>  <p>• Using 2 remote controllers for each indoor unit.</p>	<p>a. The same as above a.</p> <p>b. The same as above b.</p> <p>c. In the case of using 2 remote controllers, connect terminals 1 and 2 on transmission cable terminal block (TB15) for each indoor unit with the terminal block for 2 remote controllers.</p> <p>• Set the sub remote controller position for one of MA remote controller's main switch. Refer to the installation manual of MA remote controller.</p>
<p>3. Group operation</p>  <p>• Multiple indoor units operated together by 1 remote controller.</p>	<p>a. The same as above a.</p> <p>b. The same as above b.</p> <p>c. Connect terminals 1 and 2 on transmission cable terminal block (TB15) of each indoor unit, which is doing group operation with the terminal block the MA remote controller. Use non-polarized 2 wire.</p> <p>d. In the case of same group operation, need to set the address that is only main indoor unit. Please set the smallest address within number 01-50 of the indoor unit with the most functions in the same group.</p>
<p>Combinations of 1 through 3 above are possible.</p>	

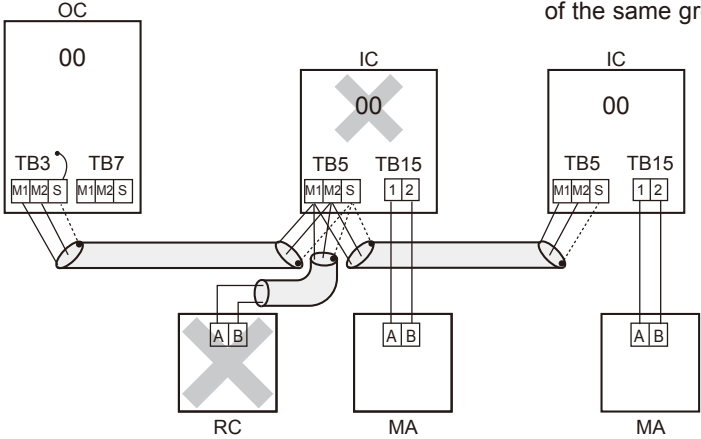
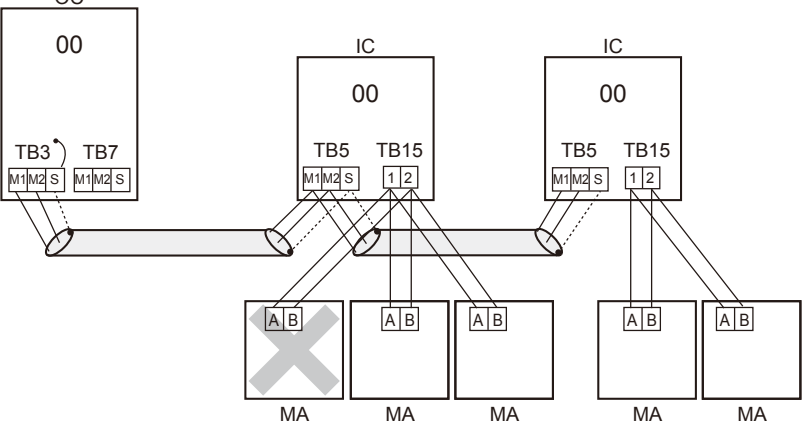
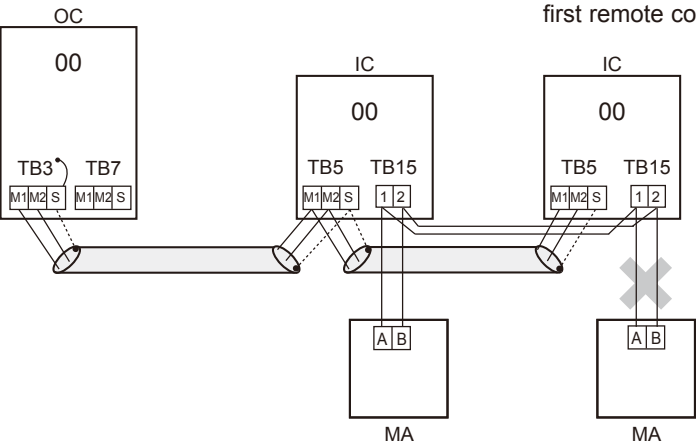

Permissible Lengths	Prohibited items
<p>Longest transmission cable length: $L_1 + L_2 \leq 200\text{m}$ (1.25 mm²)</p> <p>MA remote controller cable length: $l_1, l_2 \leq 200\text{m}$ (0.3 ~ 1.25 mm²)</p>	<p>The MA remote controller and the M-NET remote controller cannot be used together with the indoor unit of the same group.</p>  <p>The diagram shows an Outdoor Controller (OC) with terminals TB3 and TB7 connected to a main cable. This cable branches to two Indoor Controllers (IC). The first IC has terminals TB5 and TB15. It is connected to a Remote Controller (RC) at terminal TB5 and a Motorized Air (MA) remote controller at terminal TB15. The second IC also has terminals TB5 and TB15 and is connected to an MA remote controller at terminal TB15. A large 'X' is placed over the RC and the first IC, indicating this configuration is prohibited.</p>
<p>Longest transmission cable length: $L_1 + L_2 \leq 200\text{m}$ (1.25 mm²)</p> <p>MA remote controller cable length: $l_3 + l_4, l_5 + l_6 \leq 200\text{m}$ (0.3 ~ 1.25 mm²)</p>	<p>3 MA remote controller or more cannot be connected with the indoor unit of the same group.</p>  <p>The diagram shows an OC connected to two ICs. The first IC has terminals TB5 and TB15. It is connected to three MA remote controllers: one at TB5 and two at TB15. The second IC also has terminals TB5 and TB15 and is connected to two MA remote controllers at TB15. A large 'X' is placed over the first IC and its three MA remote controllers, indicating this configuration is prohibited.</p>
<p>Longest transmission cable length: $L_1 + L_2 \leq 200\text{m}$ (1.25 mm²)</p> <p>MA remote controller cable length: $l_7 + l_8 \leq 200\text{m}$ (0.3 ~ 1.25 mm²)</p>	<p>The second MA remote controller is connected with the terminal block (TB15) for the MA remote controller of the same indoor unit (IC) as the first remote control.</p>  <p>The diagram shows an OC connected to two ICs. The first IC has terminals TB5 and TB15 and is connected to one MA remote controller at TB15. The second IC also has terminals TB5 and TB15 and is connected to another MA remote controller at TB15. A large 'X' is placed over the second IC and its MA remote controller, indicating this configuration is prohibited.</p>

D. Example of a group operation with 2 or more outdoor units and a MA remote controller.
 (Address settings are necessary.)

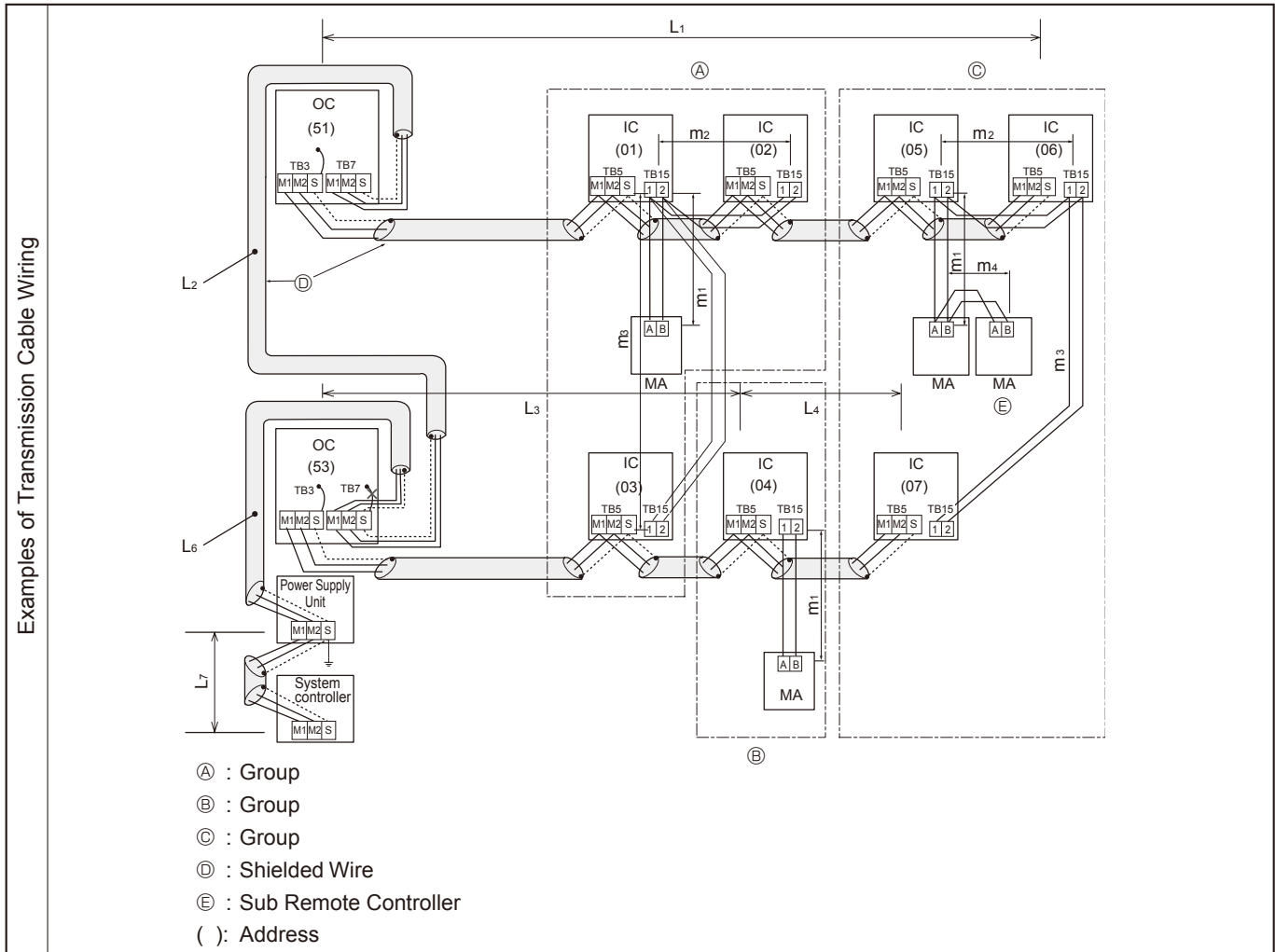

- Wiring Method Address Settings
- Always use shielded wire when making connections between the outdoor unit (OC) and the indoor unit (IC), as well for all OC-OC, and IC-IC wiring intervals.
 - Use feed wiring to connect terminals M1 and M2 and the ground terminal on the transmission cable terminal block (TB3) of each outdoor unit (OC) to terminals M1 and M2 on the terminal S on the transmission cable block of the indoor unit (IC).
 - Connect terminals M1 and M2 on the transmission cable terminal block of the indoor unit (IC) that has the most recent address within the same group to the terminal block on the remote controller (RC).
 - Connect together terminals M1, M2 and terminal S on the terminal block for centralized control (TB7) for the outdoor unit (OC).
 - DO NOT change the jumper connector CN41 on MULTI controller board.
 - The earth processing of S terminal for the centralized control terminal block (TB7) is unnecessary. Connect the terminal S on the power supply unit with the earth.
 - Set the address setting switch as follows.
- | Unit | Range | Setting Method |
|------------------------|------------|--|
| IC (Main) | 01 to 00 | Use the smallest address within the same group of indoor units. |
| IC (Sub) | 01 to 50 | Use an address, other than the IC (Main) in the same group of indoor units. This must be in sequence with the IC (Main). |
| Outdoor Unit | 51 to 100 | Use the smallest address of all the indoor units plus 50. The address automatically becomes "100" if it is set as "01 - 50". |
| Main Remote Controller | 101 to 150 | Set at an IC (Main) address within the same group plus 100. |
| Sub Remote Controller | 151 to 200 | Set at an IC (Main) address within the same group plus 150. |
| MA Remote Controller | — | Unnecessary address setting (Necessary main/ sub setting) |
- The group setting operations among the multiple indoor units is done by the remote controller (RC) after the electrical power has been turned on.
 - When connecting PWFY unit
 - For PWFY series, do not set up group connection with other indoor units.
 - LOSSNAY is not available for use with PWFY series.
 - Use a WMA remote controller for operation of PWFY series.
 For more details, refer to the service manual for PWFY series.

• Name, Symbol, and the Maximum Units for Connection

Permissible Length	<p>Longest length via outdoor unit (M-NET cable): $L_1+L_2+L_3+L_4$ and $L_1+L_2+L_6+L_7 \leq 500$ m (1.25 mm² more) Longest transmission cable length (M-NET cable): L_1 and L_3+L_4 and L_6 and L_2+L_6 and $L_7 \leq 200$ m (1.25 mm² or more) Remote controller cable length: m_1 and $m_1+m_2+m_3$ and $m_1+m_2+m_3+m_4 \leq 200$ m (0.3 to 1.25 mm²)</p>
Prohibited items	<p>(A) : Group (B) : Group (C) : Group (D) : Shielded Wire (E) : Sub Remote Controller () : Address</p> <ul style="list-style-type: none"> • Never connect together the terminal blocks (TB5) for transmission wires for indoor units (IC) that have been connected to different outdoor units (OC). • M-NET remote controller and MA remote controller cannot be connected with the indoor unit of the same group wiring together.

8-1. CHECK POINTS FOR TEST RUN

8-1-1. Procedures before test run

(1) Before a test run, make sure that the following work is completed.

- Installation related :

Make sure that the panel of cassette type and electrical wiring are done.

Otherwise electrical functions like auto vane will not operate normally.

- Piping related :

Perform leakage test of refrigerant and drain piping.

Make sure that all joints are perfectly insulated.

Check stop valves on both liquid and gas side for full open.

- Electrical wiring related :

Check ground wire, transmission cable, remote controller cable, and power supply cable for secure connection.

Make sure that all switch settings of address or adjustments for special specification systems are correctly settled.

(2) Safety check :

With the insulation tester of 500V, inspect the insulation resistance.

Do not touch the transmission cable and remote controller cable with the tester.

The resistance should be over 1.0 MΩ. Do not proceed inspection if the resistance is under 1.0 MΩ.

Inspect between the outdoor unit power supply terminal block and ground first, metallic parts like refrigerant pipes or the electrical box next, then inspect all electrical wiring of outdoor unit, indoor unit, and all linked equipment .

(3) Before operation :

a) Turn the power supply switch of the outdoor unit to on for compressor protection. For a test run, wait at least 12 hours from this point.

b) Register control systems into remote controller(s). Never touch the on/off switch of the remote controller(s). Refer to “ 8-1-2. Special Function Operation and Settings (for M-NET Remote Controller)” as for settings. In MA remote controller(s), this registration is unnecessary.

(4) More than 12 hours later from power supply to the outdoor unit, turn all power switch to on for the test run. Perform test run according to the “Operation procedure” table of the bottom of this page. While test running, make test run reports .

8-1-1-1. Test run for M-NET Remote controller

When you deliver the unit after the test run, instruct the end user for proper usage of the system using owners' manual and the test run report you made to certificate normal operation. If abnormalities are detected during test run, refer to “8-1-3 Countermeasures for Error During Test Run”. As for DIP switch setting of outdoor unit, refer to “8-5. INTERNAL SWITCH FUNCTION TABLE”.

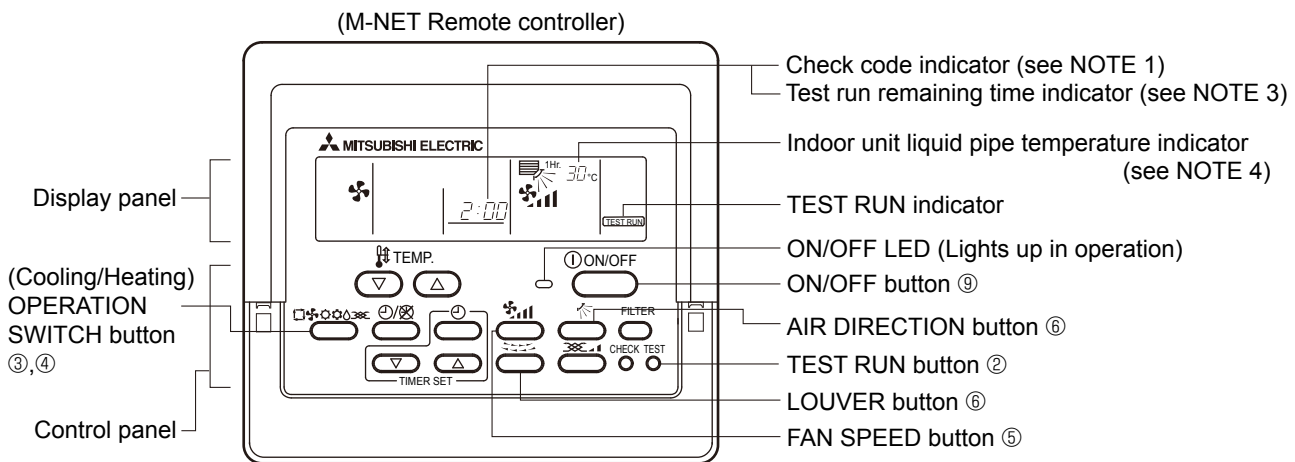

Operation procedure

①	Turn on the main power supply of all units at least 12 hours before test run. "HO" appears on display panel for 3 min.
②	12 hours later, press TEST RUN button twice to perform test run. "TEST RUN " appears on display panel.
③	Press OPERATION SWITCH button to make sure that air blows out.
④	Select Cooling (or Heating) by OPERATION SWITCH button to make sure that cool (or warm) air blows out.
⑤	Press Fan speed button to make sure that fan speed is changed by the button.
⑥	Press AIR DIRECTION button or LOUVER button to make sure that air direction is adjustable (horizontal, downward, upward, and each angle).
⑦	Check outdoor fans for normal operation.
⑧	Check interlocked devices (like ventilator) for normal operation, if any. This is the end of test run operation.
⑨	Press ON/OFF button to stop and cancel test run.

Notes:

1. If error code appears on remote controller or remote controller malfunctions, refer to “ 8-1-3 Countermeasures for Error During Run”.
2. During test run operation, 2-hour off timer activates automatically and remaining time is on remote controller and test run stops 2 hours later.
3. During test run, the indoor liquid pipe temperature is displayed on remote controller instead of room temperature.
4. Depending on a model, “This function is not available” appears when air direction button is pressed. However, this is not malfunction.

8-1-1-2. Test run for wired remote controller <PAR-31MAA>

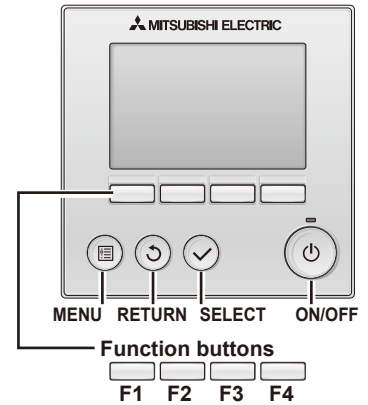

① Select "Service" from the Main menu, and press the button.



Select "Test run" with the **F1** or **F2** button, and press the button.

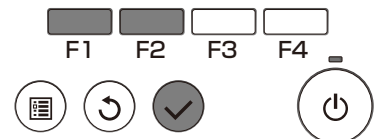
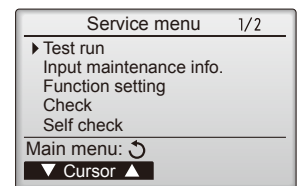

② Select "Test run" with the **F1** or **F2** button, and press the button.

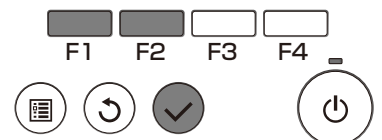
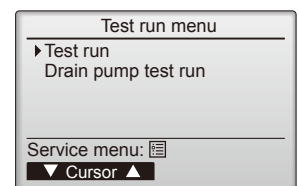

Test run operation

Press the **F1** button to go through the operation modes in the order of "Cool and Heat".

Cool mode: Check the cold air blow off.
Heat mode: Check the heat blow off.



Press the button and open the Vane setting screen.

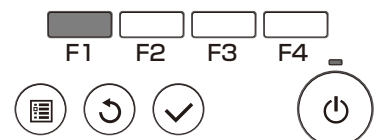
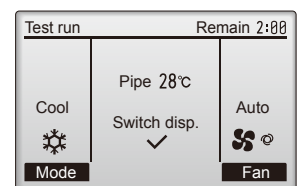

Auto vane check*

Check the auto vane with the **F1** **F2** buttons.
 Check the operation of the outdoor unit fan, also.



Press the button to return to "Test run operation".



Press the button.

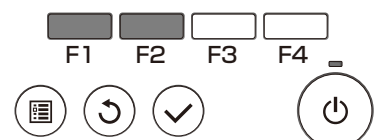
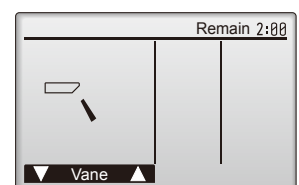

When the test run is completed, the "Test run menu" screen will appear.
 The test run will automatically stop after two hours.

*The function is available only for the model with vanes.

8-1-2. Special Function Operation and Settings (for M-NET Remote Controller)

- It is necessary to perform "group settings" and "paired settings" at making group settings of different refrigerant systems (multiple outdoor unit).
 - (A) Group settings: Enter the indoor unit controlled by the remote controller, check the content of entries, and clear entries, etc.
 - (B) Paired settings: Used to set the linked operation of a Lossnay unit.

(1) Entering address: Follow the steps below to enter the addresses of the indoor unit using the remote controller.

a) Group settings



- Turning off the remote controller: Press the ON/OFF button to stop operation (the indicator light will go off).
- Changing to indoor unit address display mode: If the FILTER and  buttons on the remote controller are pressed simultaneously and held for 2 seconds, the display shown in Figure 1 will appear.
- Changing address: Press the temperature adjustment  buttons to change the displayed address to the address to be entered.
- Entering the displayed address: Press the TEST RUN button to enter the indoor unit with the displayed address. The type of the unit will be displayed as shown in Figure 2 if entry is completed normally. If a selected indoor unit does not exist, an error signal will be displayed as shown in Figure 3. When this happens, check whether the indoor unit actually exists and perform entry again.
- Returning to the normal mode after completing entry: Press the FILTER and  buttons simultaneously and hold for 2 seconds to return to the normal mode.

Figure 1. (A) Group setting display

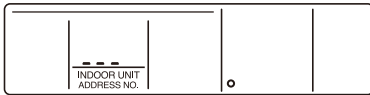

Figure 2. Normal completion of entry



Type of unit is displayed.

Figure 3. Entry error signal





Flashing "88" indicates entry error.

b) Paired Settings

- Turn off the remote controller: Press the remote controller's ON/OFF button to turn it off (the indicator light will go off).
- Put in indoor unit address display mode: Press the FILTER and  buttons on the remote controller simultaneously and hold for 2 seconds.

Note: The above steps are the same as when making group settings (A).
- Changing to the linked operation unit address display state: The display shown in Figure 4 will appear when the  button on the remote control is pressed.
- Displaying the address of the Lossnay unit and linked indoor unit: In this situation, the indoor unit number will be the lowest address of the group. The Lossnay unit will not operate if this setting is incorrect.

Notes:

- If the temperature adjustment  buttons are pressed, the address may be changed to the indoor unit that are to be linked.
 - If the time setting  buttons are pressed, the address of the linked units may be changed to the address where it is desired to enter the Lossnay.
- Linking the Lossnay and the indoor unit: The display shown in Figure 5 will appear when the TEST RUN button is pressed. The indoor unit whose address is displayed and the Lossnay unit with a linked address will operate in a linked manner.

Notes:

 - If it is desired to display the address of the Lossnay in the indoor unit address, display the indoor unit address in the linked unit address, and the above content will also be recorded.
 - Apart from the indoor unit with the lowest address in the group, display and enter the addresses of the other indoor unit that are to be linked with the Lossnay unit.
 - Returning to the normal mode after completing entry: Press the FILTER and  buttons on the remote controller simultaneously and hold for 2 seconds to return to the normal mode.

Figure 4. (B) Making paired settings



The addresses of indoor unit and linked units are displayed simultaneously.

Figure 5. Completing normal entry

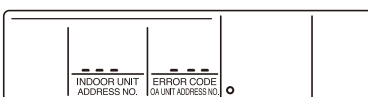
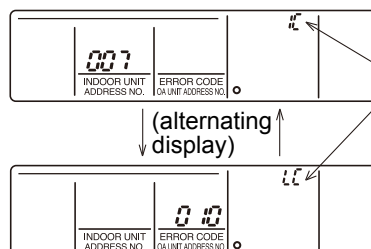

These alternating IC or LC displays will appear when entry is completed normally.

A flashing "88" will appear if there is a problem with the entry (indicating that the unit does not exist).

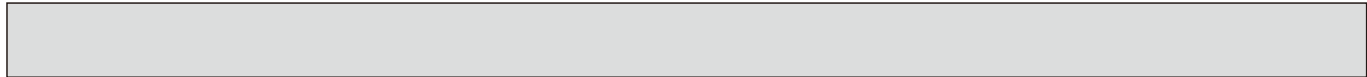

(2) Address check: Refer to section (1) regarding address entry.

a) In making group settings:

- Turn off the remote controller: Press the remote controller's ON/OFF button to stop operation (the indicator light will go off).
- Locate the indoor unit address display mode: Press the FILTER and buttons on the remote controller simultaneously and hold for 2 seconds.
- Display indoor unit address: The entered indoor units address and type will be displayed each time the button is pressed.
* When 1 entry is made, only 1 address will be displayed no matter how many times the button is pressed.
- Returning to the normal mode after completing check: Simultaneously press the FILTER and buttons on the remote controller and hold for 2 seconds to return to the normal mode.

b) In making paired settings:

- Turn off the remote controller: Press the remote controller's ON/OFF button to stop operation (the indicator light will go off).
- Put in indoor unit address display mode: Press the FILTER and buttons on the remote controller simultaneously and hold for 2 seconds.
- Changing to the linked operation unit address display state: Press the button on the remote control.
- Displaying the address of the indoor unit to be checked: Change the address to that of the indoor unit to be checked by pressing the temperature adjustment buttons .
- Displaying the address of the linked Lossnay unit: Press the button to display the addresses of the linked Lossnay and indoor unit in alternation.
- Displaying the addresses of other entered units: The addresses of the other entered units will be displayed in alternating fashion after resting the button again.
- Returning to the normal mode after completing the check: Simultaneously press the FILTER and buttons on the remote controller and hold for 2 seconds to return to the normal mode.

(3) Clearing an address: Refer to section (1) regarding the address entry and section (2) regarding checking addresses.

a) In making group settings:

- Turn off the remote controller: The procedure is same as **a)** in (2) Address check.
- Put in the indoor unit address display mode: The procedure is same as **a)** in (2) Address check.
- Displaying the indoor unit address to be cleared: The procedure is same as **a)** in (2) Address check.
- Clearing indoor unit address : Pressing the button on the remote controller twice will clear the address entry of the displayed indoor unit, resulting in the display shown in Figure 6.
The display shown in Figure 7 will appear if an abnormality occurs and the entry is not cleared.
Please repeat the clearing procedure.
- Returning to the normal mode after clearing an address: The procedure is same as **a)** in (2) Address check.

Figure 6. Display after address has been cleared normally

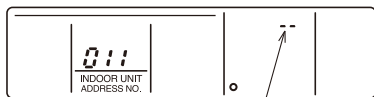

"--" will appear in the room temperature display location.

Figure 7. Display when an abnormality has occurred during clearing



"88" will appear in the room temperature display location.

b) In making paired settings:

- Turn off the remote controller: The procedure is same as **b)** in (2) Address check.
- Put into the indoor unit address display mode: The procedure is same as **b)** in (2) Address check.
- Put into the linked unit address display mode: The procedure is same as **b)** in (2) Address check.
- Display the address of the Lossnay unit or the indoor unit to be cleared.
- Deleting the address of a linked indoor unit: Pressing the button on the remote controller twice will clear the address entry of the displayed indoor unit, resulting in the display shown in Figure 8.
- Returning to the normal mode after clearing an address: The procedure is same as **b)** in (2) Address check.

Figure 8. Display after address has been cleared normally

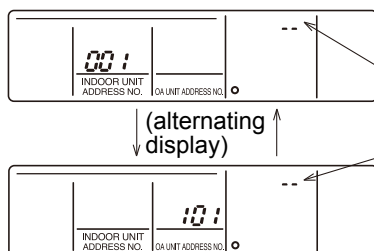

"--" will appear in the unit type display location when an address has been cleared normally.

"88" will appear in the unit type display location when an abnormality has occurred during clearing.

8-1-3. Countermeasures for Error During Test Run

- If a problem occurs during test run, a code number will appear on the remote controller (or LED on the outdoor unit), and the air conditioning system will automatically cease operating.

Determine the nature of the abnormality and apply corrective measures.

Check code	Trouble	Detected Unit			Remarks
		Indoor	Outdoor	Remote Controller	
0403	Serial communication error		○		Outdoor unit Multi controller board ~ Power board communication trouble
1102	Compressor temperature		○		Check delay code 1202
1300	Low pressure		○		
1302	High pressure		○		Check delay code 1402
1500	Superheat due to low discharge temperature		○		Check delay code 1600
1501	Refrigerant shortage		○		Check delay code 1601
	Blocked valve in cooling mode		○		Check delay code 1501
1508	4-way valve trouble in heating mode		○		Check delay code 1608
2500	Water leakage	○			
2502	Drain over flow protection	○			
2503	Drain sensor abnormality	○			
4100	Compressor current interruption (locked compressor)		○		Check delay code 4350
4210	Compressor overcurrent interruption		○		
4220	Voltage shortage/overvoltage/PAM error/L1open phase/power synchronization signal error		○		Check delay code 4320
4230	Heat Sink temperature		○		Check delay code 4330
4250	Power module		○		Check delay code 4350
4400	Rotational frequency of outdoor fan motor		○		Check delay code 4500
5101	Air inlet thermistor trouble (TH21) or Compressor temperature thermistor (TH4) open/short	○			Check delay code 1202
	Liquid pipe temperature thermistor trouble (TH22)	○			
5102	Suction pipe temperature thermistor (TH6) open/short		○		Check delay code 1211
	Gas pipe temperature thermistor trouble (TH23)	○			
5103	Outdoor liquid pipe temperature thermistor (TH3) open/short		○		Check delay code 1205
5106	Ambient thermistor (TH7) open/short		○		Check delay code 1221
5109	HIC pipe temperature thermistor (TH2) open/short		○		Check delay code 1222
5110	Heat Sink temperature thermistor (TH8) open/short		○		Check delay code 1214
5201	High pressure sensor (63HS)		○		Check delay code 1402
5202	Low pressure sensor (63LS)		○		Check delay code 1400
5300	Primary current		○		Check delay code 4310
5701	Contact failure of drain float switch	○			
6600	Duplex address error	○	○	○	Only M-NET Remote controller is detected.
6602	Transmission processor hardware error	○	○	○	Only M-NET Remote controller is detected.
6603	Transmission bus BUSY error	○	○	○	Only M-NET Remote controller is detected.
6606	Signal communication error with transmission processor	○	○	○	Only M-NET Remote controller is detected.
6607	No ACK error	○		○	Only M-NET Remote controller is detected. *
6608	No response frame error	○		○	Only M-NET Remote controller is detected. *
6831	MA communication receive error (no receive signal)	○		○	Only MA Remote controller is detected.
6832	MA communication send error	○		○	Only MA Remote controller is detected.
6833	MA communication send error	○		○	Only MA Remote controller is detected.
6834	MA communication receive error	○		○	Only MA Remote controller is detected.
7100	Total capacity error		○		
7101	Capacity code error	○	○		
7102	Connecting excessive number of units		○		
7105	Address setting error		○		

Note:
When the outdoor unit detects No ACK error/No response error, an object indoor unit is treated as a stop, and not assumed to be abnormal.
 *Abnormality for PWFY series

Self-diagnosis function

The indoor and outdoor units can be diagnosed automatically using the self-diagnosis switch (SW1) and LED1, LED2 (LED indication) found on the multi-controller of the outdoor unit.
 LED indication : Set all contacts of SW1 to OFF.

During normal operation

The LED indicates the drive state of the controller in the outdoor unit.

[Example]

When the compressor and SV1 are turned during cooling operation.

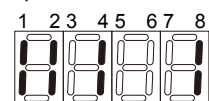

Bit	1	2	3	4	5	6	7	8
Indication	Compressor operated	52C	21S4	SV1	(SV2)	—	—	Always lit

Check code

0403

Serial communication error

Abnormal points and detection methods	Causes and check points
Abnormal if serial communication between the outdoor controller board and outdoor power board is defective.	<ul style="list-style-type: none">① Wire breakage or contact failure of connector CN2 or CN4② Malfunction of power board communication circuit on outdoor controller board③ Malfunction of communication circuit on outdoor power board

●Diagnosis of defectives

Make sure to turn the power OFF before connecting/disconnecting any connectors, or replacing boards.

Diagnosis	Remedy
<p>Check the connection of the communication line (CN2 and CN4) between the outdoor controller board and power board.</p> <p>Are they connected normally?</p> <p>No</p> <p>Yes</p>	<p>Connect the CN2 and CN4 properly. Replace them in case of a breakage.</p> <p>The communication circuit of either the outdoor controller board or power board is defective. If unable to identify the defective circuit; ①Replace the outdoor controller board if it doesn't recover, ②Replace the outdoor power board</p>

Compressor temperature trouble

Abnormal points and detection methods	Causes and check points
<p>(1) Abnormal if TH4 falls into following temperature conditions;</p> <ul style="list-style-type: none"> ●exceeds 110°C [230 °F]continuously for 5 minutes ●exceeds 125°C [257 °F] <p>(2) Abnormal if a pressure detected by the high-pressure sensor and converted to saturation temperature exceeds 40°C [104 °F]during defrosting, and TH4 exceeds 110°C [230 °F].</p> <p>TH4: Thermistor <Compressor> LEV: Electronic expansion valve</p>	<ul style="list-style-type: none"> ① Malfunction of stop valve ② Over-heated compressor operation caused by shortage of refrigerant ③ Defective thermistor ④ Defective outdoor controller board ⑤ LEV performance failure ⑥ Defective indoor controller board ⑦ Clogged refrigerant system caused by foreign object ⑧ Refrigerant shortage while in heating operation (Refrigerant liquid accumulation in compressor while indoor unit is OFF/thermo-OFF.)

●Diagnosis of defectives

Make sure to turn the power OFF before connecting/disconnecting any connectors, or replacing boards.

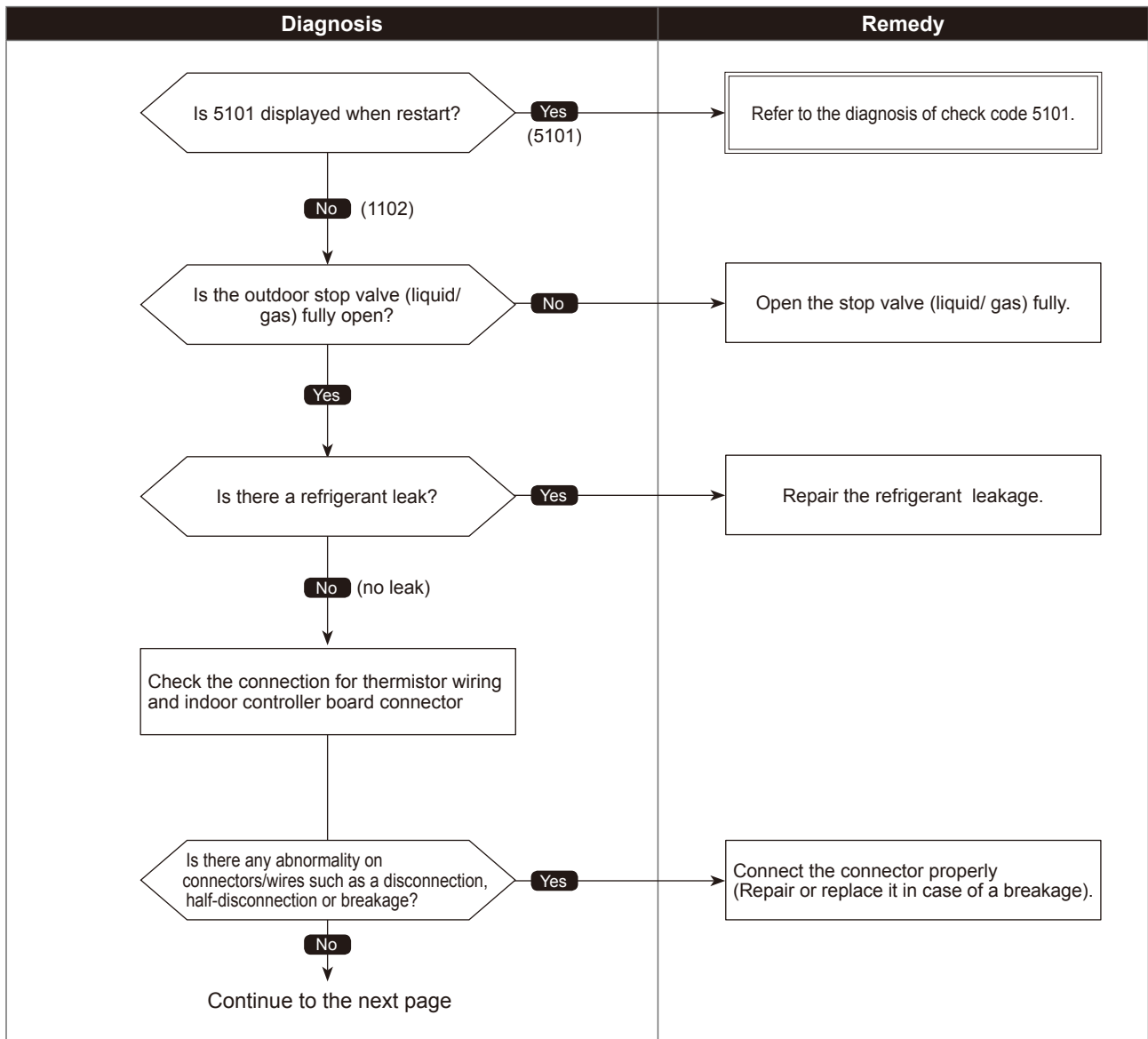

Compressor temperature trouble

●Diagnosis of defectives

Make sure to turn the power OFF before connecting/disconnecting any connectors, or replacing boards.

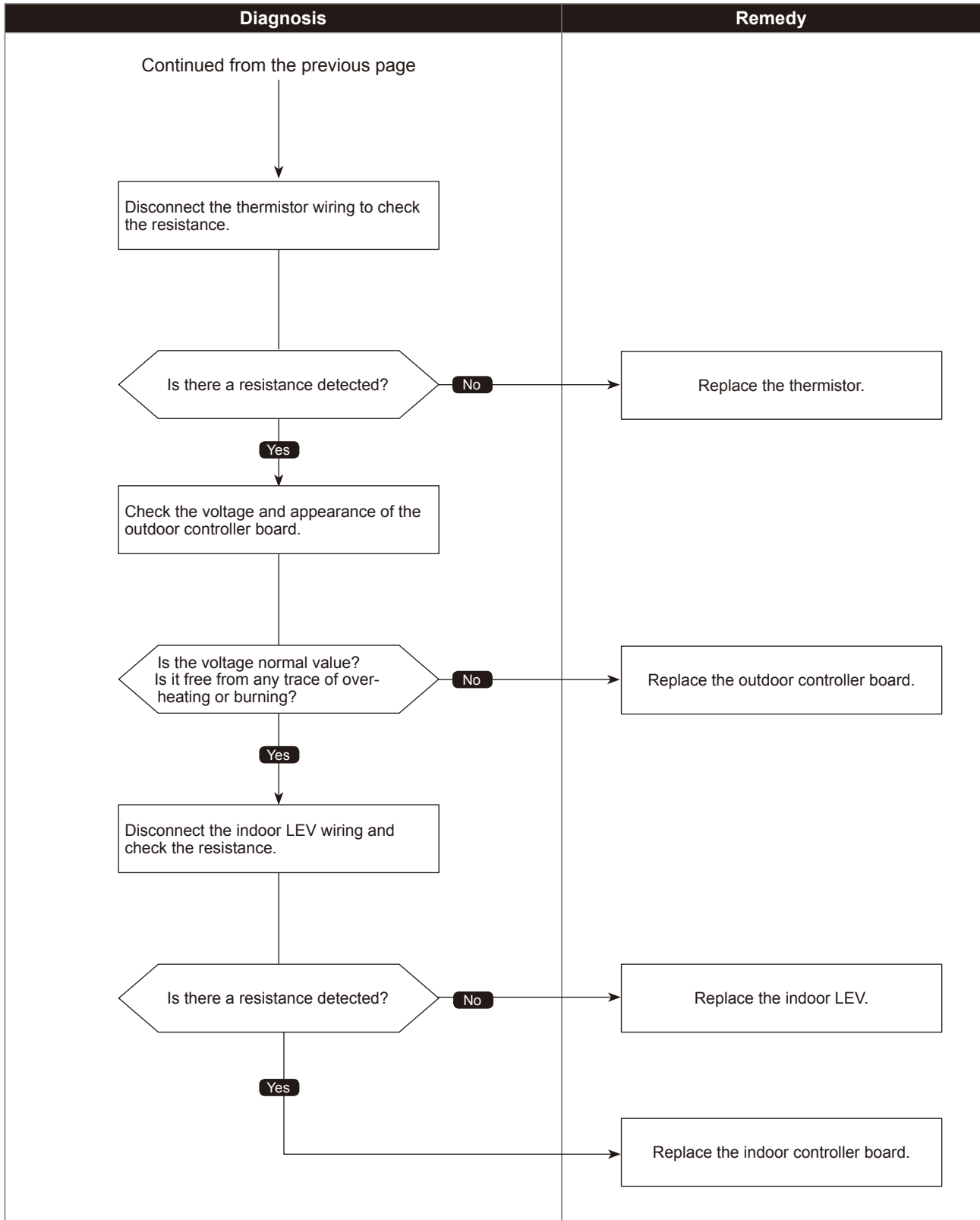

Abnormal points and detection methods	Causes and check points
<p><63L equipped model> (1) Low pressure (63L is in operation) Abnormal if 63L operates (under-0.03MPa) during compressor operation.</p> <p>63L : Low pressure switch LEV : Electronic expansion valve SV1 : Solenoid valve TH7 : Thermistor <Ambient></p>	<p>① Defective operation of stop valve (not fully open) ② Clogged or broken pipe. ③ Malfunction or locked outdoor fan motor ④ Short-cycle of outdoor unit ⑤ Dirt of outdoor heat exchanger ⑥ Remote controller transmitting error caused by noise interference ⑦ Contact failure of outdoor controller board connector ⑧ Defective outdoor controller board ⑨ Short-cycle of indoor unit ⑩ Decreased airflow, clogged filter, or dirt on indoor unit. ⑪ Malfunction or locked indoor fan motor. ⑫ Decreased airflow caused by defective inspection of outdoor temperature thermistor (It detects lower temperature than actual temperature.) ⑬ Indoor LEV performance failure ⑭ Malfunction of fan driving circuit ⑮ SV1 performance failure ⑯ Defective low-pressure sensor ⑰ Malfunction of low-pressure sensor input circuit on outdoor controller board</p>

●Diagnosis of defectives

Make sure to turn the power OFF before connecting/disconnecting any connectors, or replacing boards.

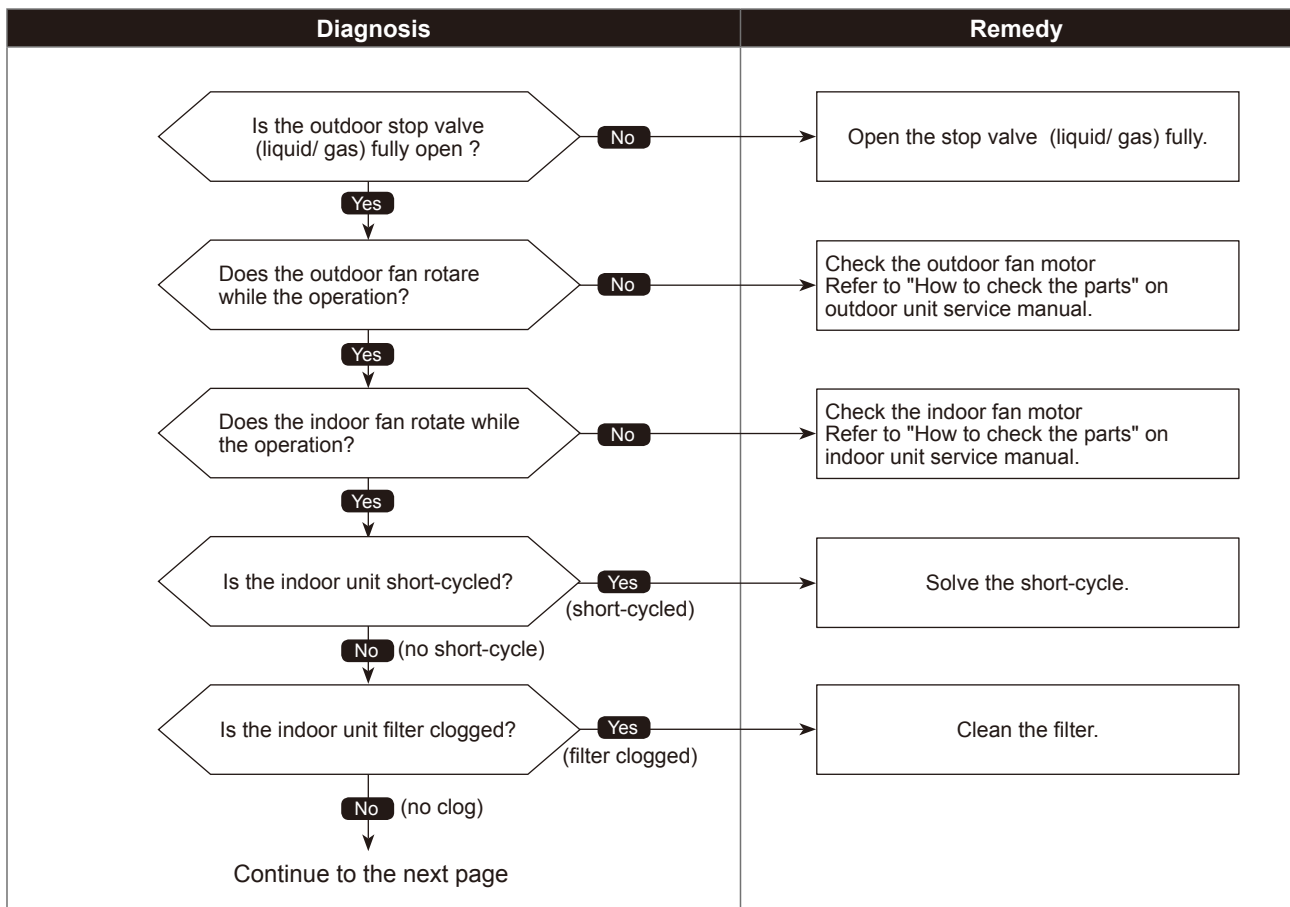

●Diagnosis of defectives

Make sure to turn the power OFF before connecting/disconnecting any connectors, or replacing boards.

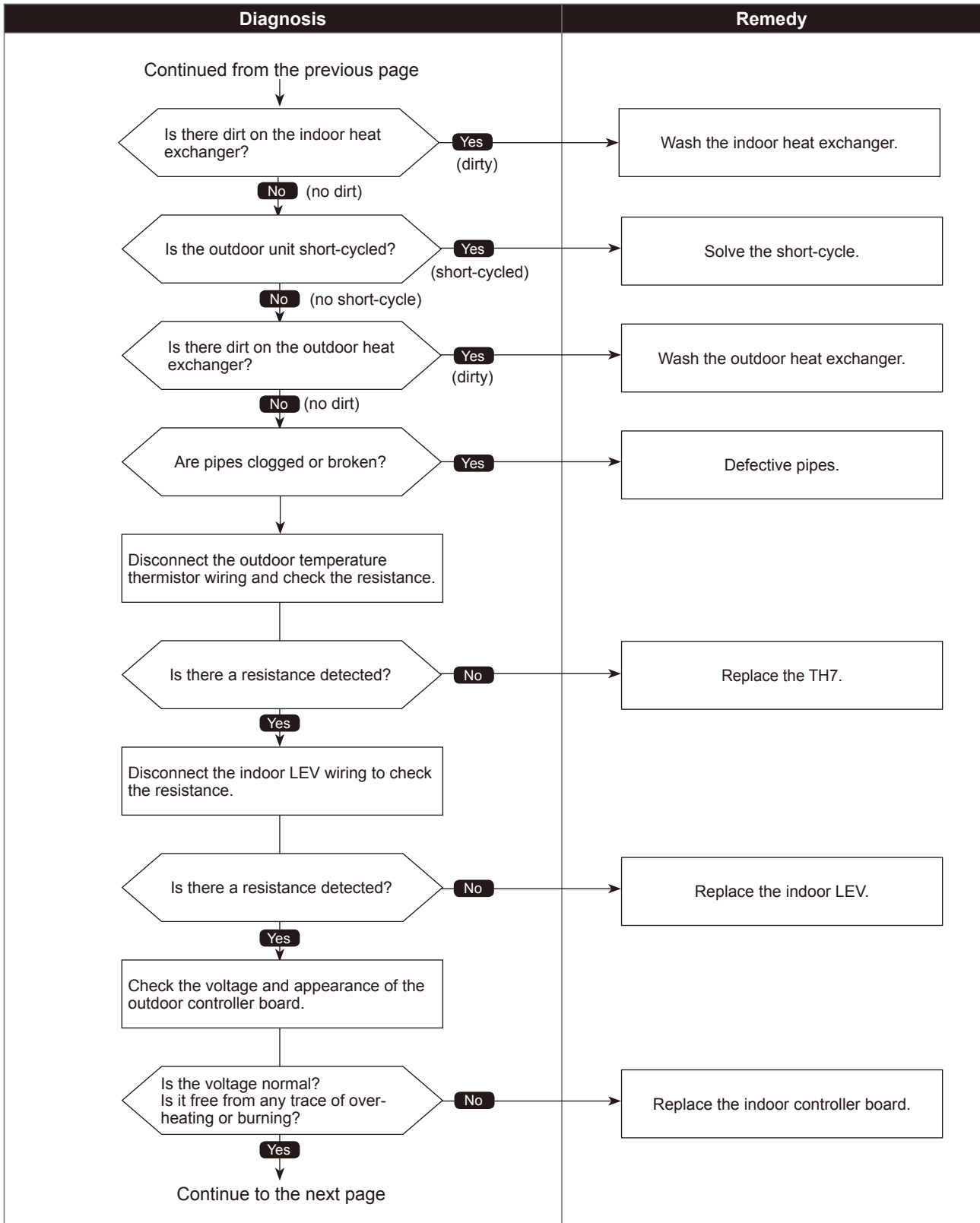

●Diagnosis of defectives

Make sure to turn the power OFF before connecting/disconnecting any connectors, or replacing boards.

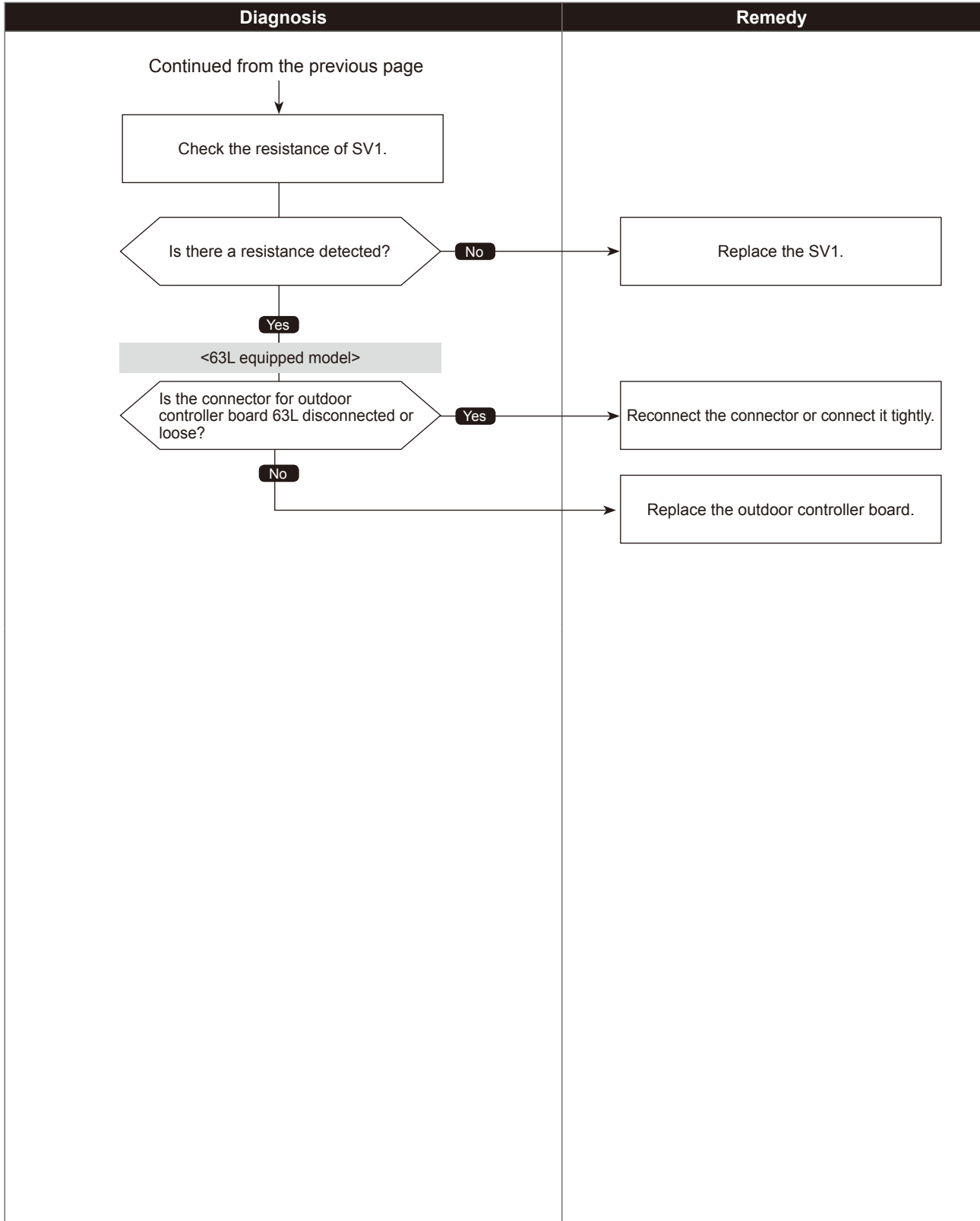

Abnormal points and detection methods	Causes and check points
<p><63H equipped model (63HS non-equipped)> (1) High pressure abnormality (63H operation) Abnormal if 63H operates(*) during compressor operation. (* 4.15MPa)</p> <p><63HS equipped model (63H non-equipped)> (2) High pressure abnormality (63HS detected) Abnormal if a pressure detected by 63HS exceeds 4.15MPa during compressor operation.</p> <p>63H : High-pressure switch 63HS: High-pressure sensor LEV : Electronic expansion valve SV1 : Solenoid valve TH7 : Thermistor <Ambient></p>	<p>① Defective operation of stop valve (not fully open) ② Clogged or broken pipe. ③ Malfunction or locked outdoor fan motor ④ Short-cycle of outdoor unit ⑤ Dirt of outdoor heat exchanger ⑥ Remote controller transmitting error caused by noise interference ⑦ Contact failure of the outdoor controller board connector ⑧ Defective outdoor controller board ⑨ Short-cycle of indoor unit ⑩ Decreased airflow, clogged filter, or dirt on indoor unit. ⑪ Malfunction or locked indoor fan motor. ⑫ Decreased airflow caused by defective inspection of outdoor temperature thermistor (It detects lower temperature than actual temperature.) ⑬ Indoor LEV performance failure ⑭ Malfunction of fan driving circuit ⑮ SV1 performance failure ⑯ Defective high-pressure sensor ⑰ Defective high-pressure sensor input circuit on outdoor controller board</p>

●Diagnosis of defectives

Make sure to turn the power OFF before connecting/disconnecting any connectors, or replacing boards.

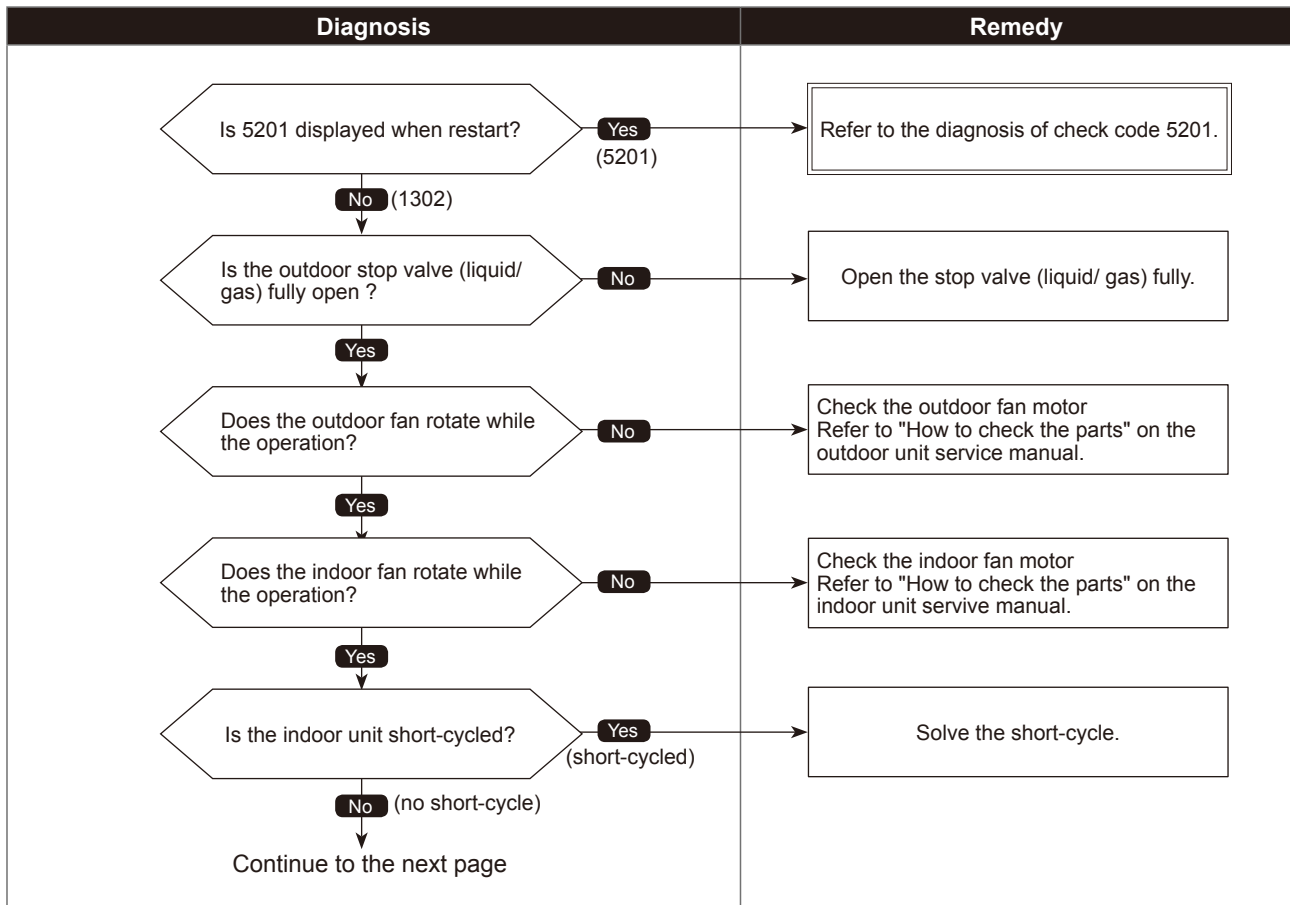

●Diagnosis of defectives

Make sure to turn the power OFF before connecting/disconnecting any connectors, or replacing boards.

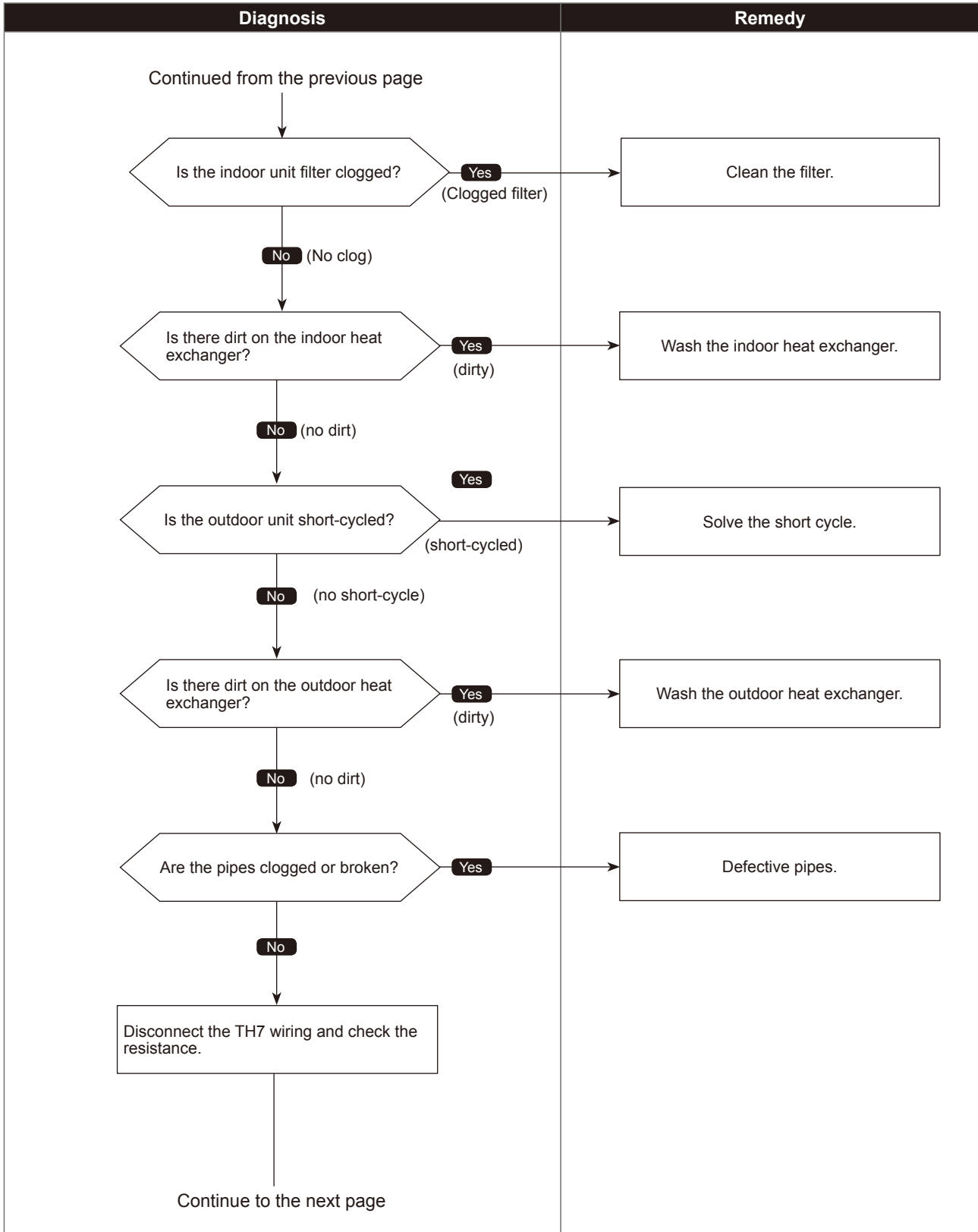

●Diagnosis of defectives

Make sure to turn the power OFF before connecting/disconnecting any connectors, or replacing boards.

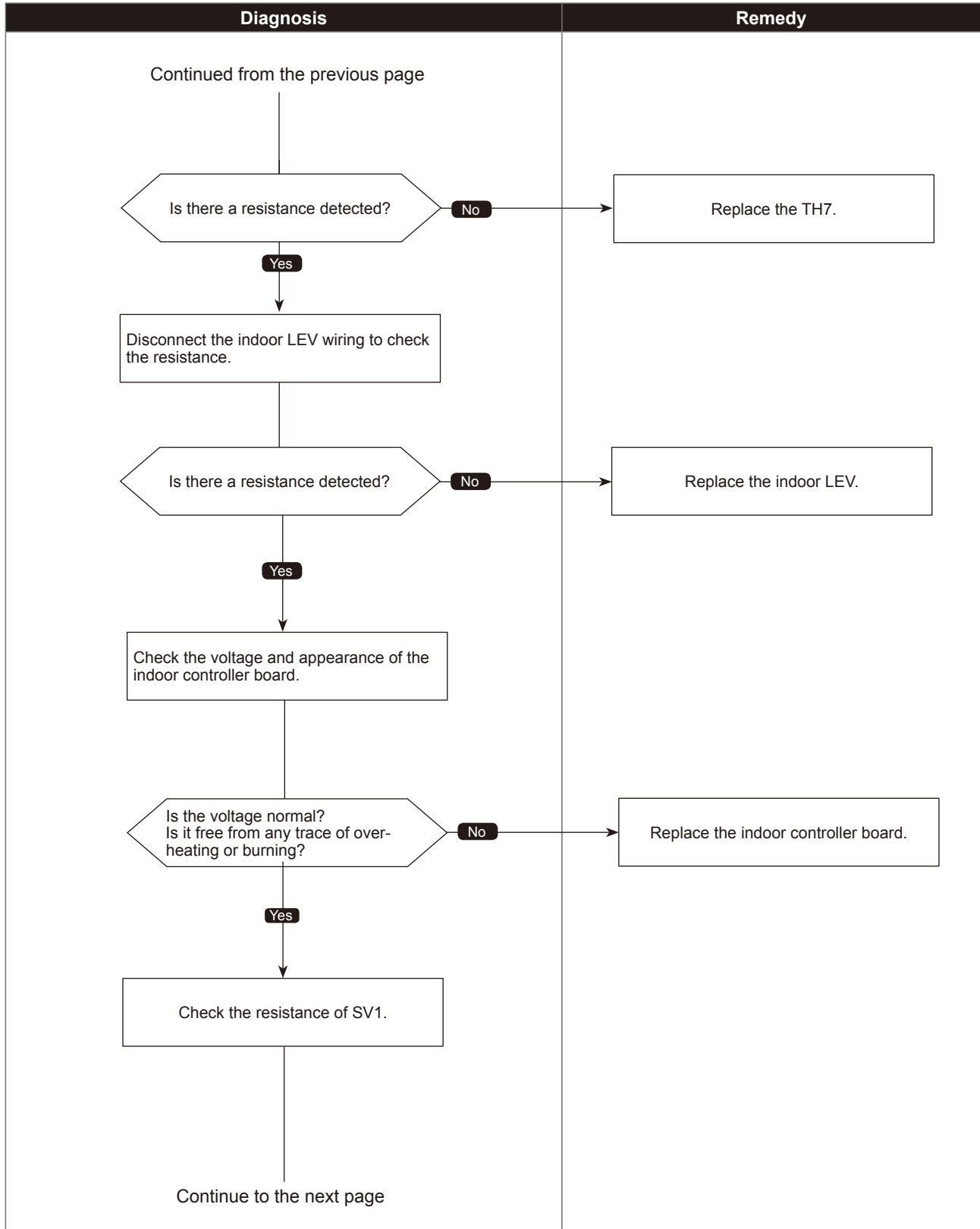

•Diagnosis of defectives

Make sure to turn the power OFF before connecting/disconnecting any connectors, or replacing boards.

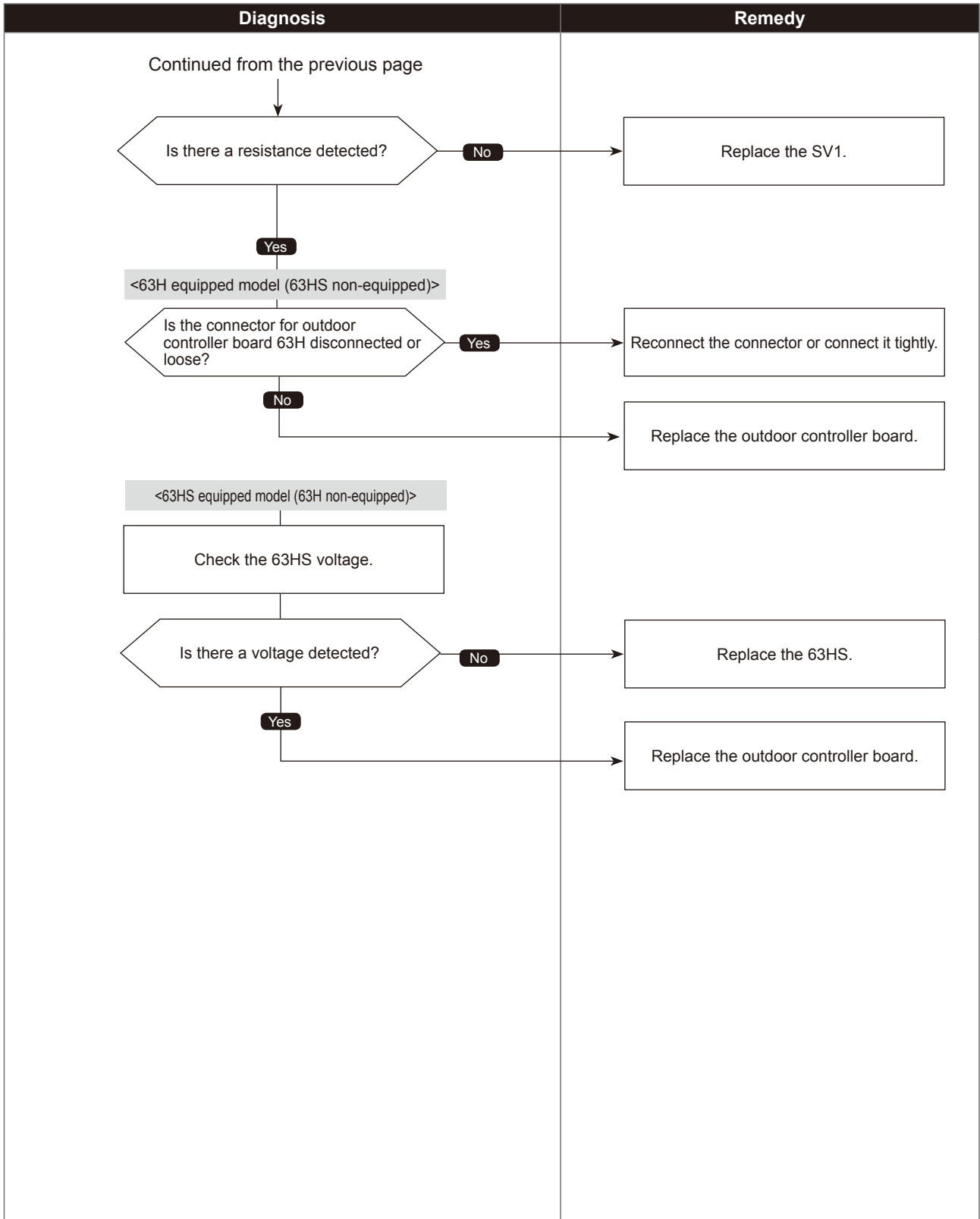

Superheat due to low discharge temperature trouble

Abnormal points and detection methods	Causes and check points
<p>Abnormal if the discharge superheat is continuously detected less than or equal to -15°C [5°F]* for 5 minutes even though the indoor LEV has minimum open pulse after the compressor starts operating for 10 minutes.</p> <p>LEV : Electronic expansion valve TH4 : Thermistor <Compressor> 63HS: High-pressure sensor</p> <p>*At this temperature, conditions for the abnormality detection will not be satisfied if no abnormality is detected on either TH4 or 63HS.</p>	<p>① Disconnection or loose connection of TH4 ② Defective holder of TH4 ③ Disconnection of LEV coil ④ Disconnection of LEV connector ⑤ LEV performance failure</p>

●Diagnosis of defectives

Make sure to turn the power OFF before connecting/disconnecting any connectors, or replacing boards.

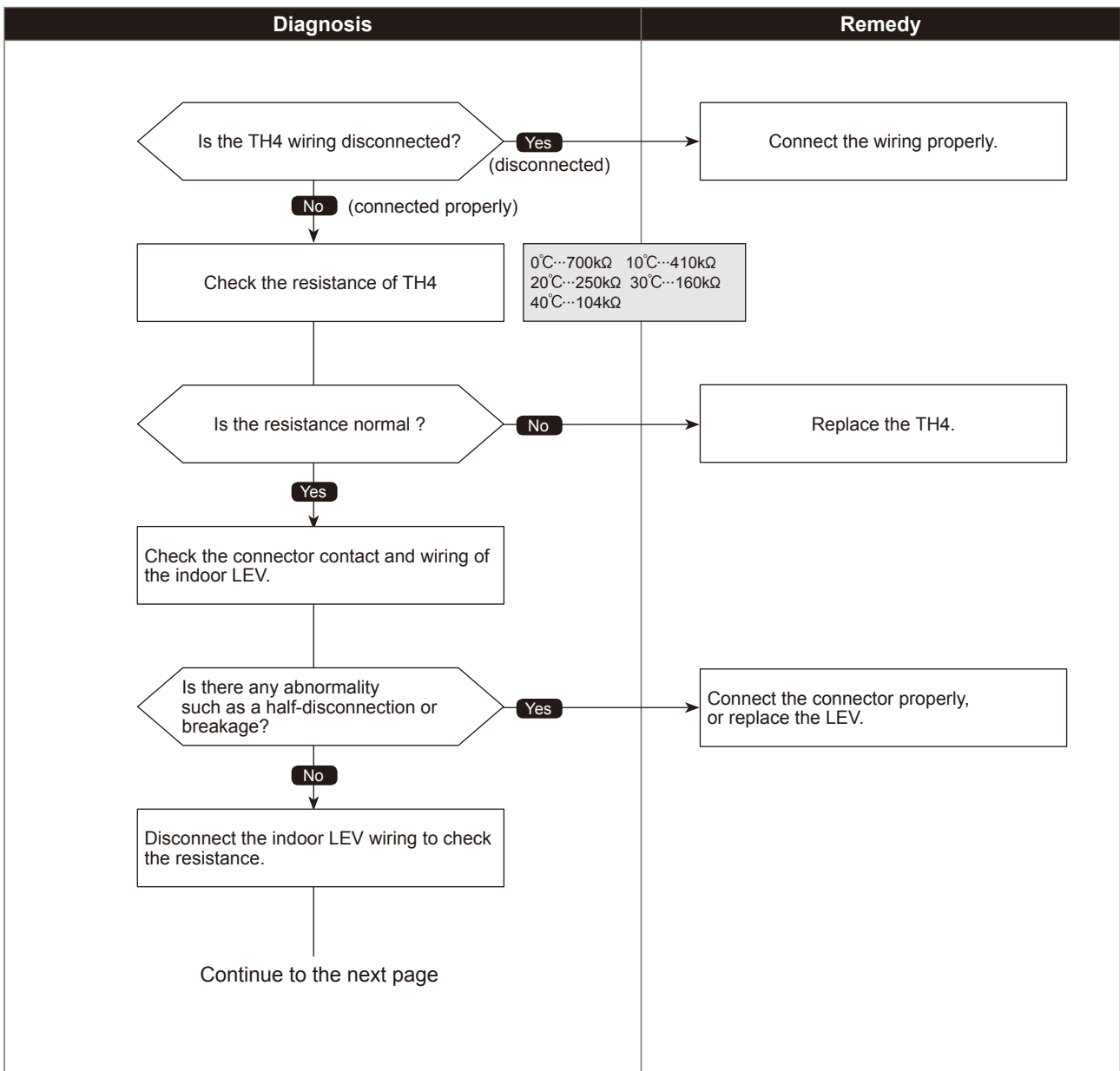

●Diagnosis of defectives

Make sure to turn the power OFF before connecting/disconnecting any connectors, or replacing boards.

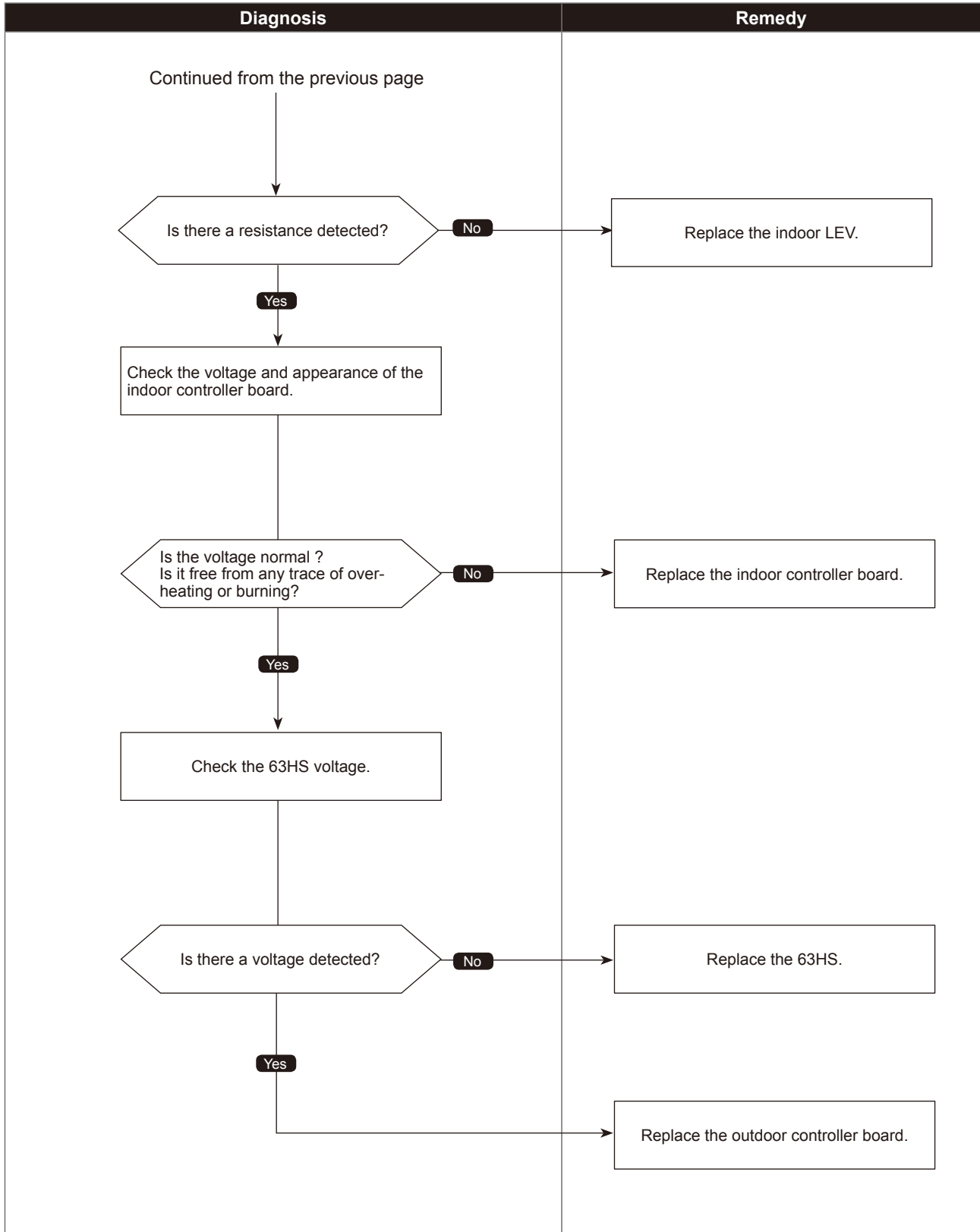

Refrigerant shortage trouble

Abnormal points and detection methods	Causes and check points
<p>(1) Abnormal when all of the following conditions are satisfied:</p> <ol style="list-style-type: none"> 1. The compressor is operating in HEAT mode 2. Discharge super heat is 80 °C or more. 3. Difference between TH7 and the TH3 applies to the formula of (TH7-TH3 < 5 °C) 4. The 63HS detects below 2.04 MPa. <p>(2) Abnormal when all of the following conditions are satisfied:</p> <ol style="list-style-type: none"> 1. The compressor is in operation 2. When cooling, discharge superheat is 80 °C or more When heating, discharge superheat is 90 °C or more. The High-pressure sensor detects below 2.32 MPa 	<ol style="list-style-type: none"> ① Defective operation of stop valve (not fully open) ② Defective thermistor ③ Defective outdoor controller board ④ Indoor LEV performance failure ⑤ Gas leakage or shortage ⑥ Defective 63HS <p>TH3 : Thermistor <Outdoor liquid pipe> TH7 : Thermistor <Ambient> LEV : Electronic expansion valve 63HS: High-pressure sensor</p>

●Diagnosis of defectives

Make sure to turn the power OFF before connecting/disconnecting any connectors, or replacing boards.

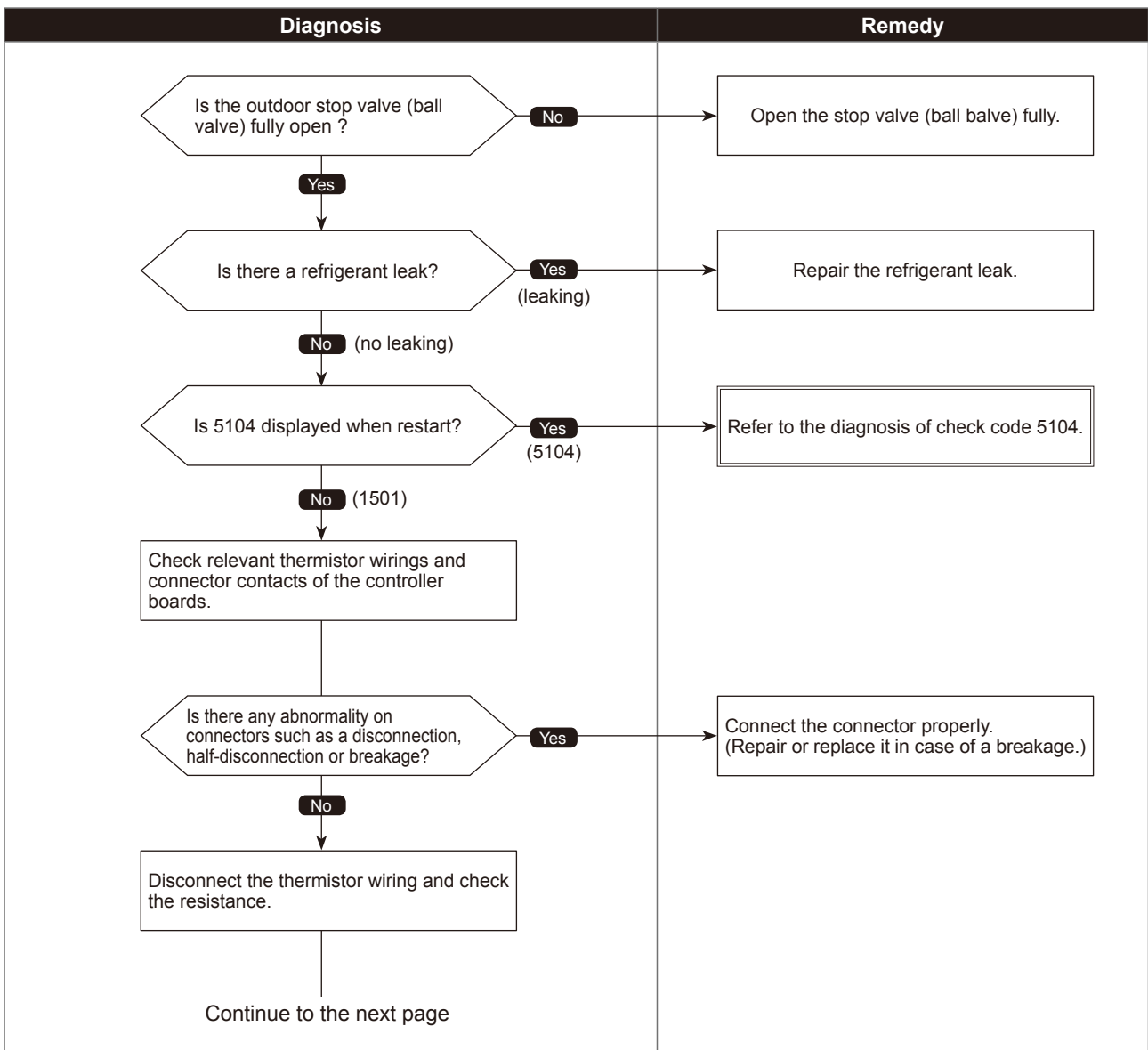

Refrigerant shortage trouble

●Diagnosis of defectives

Make sure to turn the power OFF before connecting/disconnecting any connectors, or replacing boards.

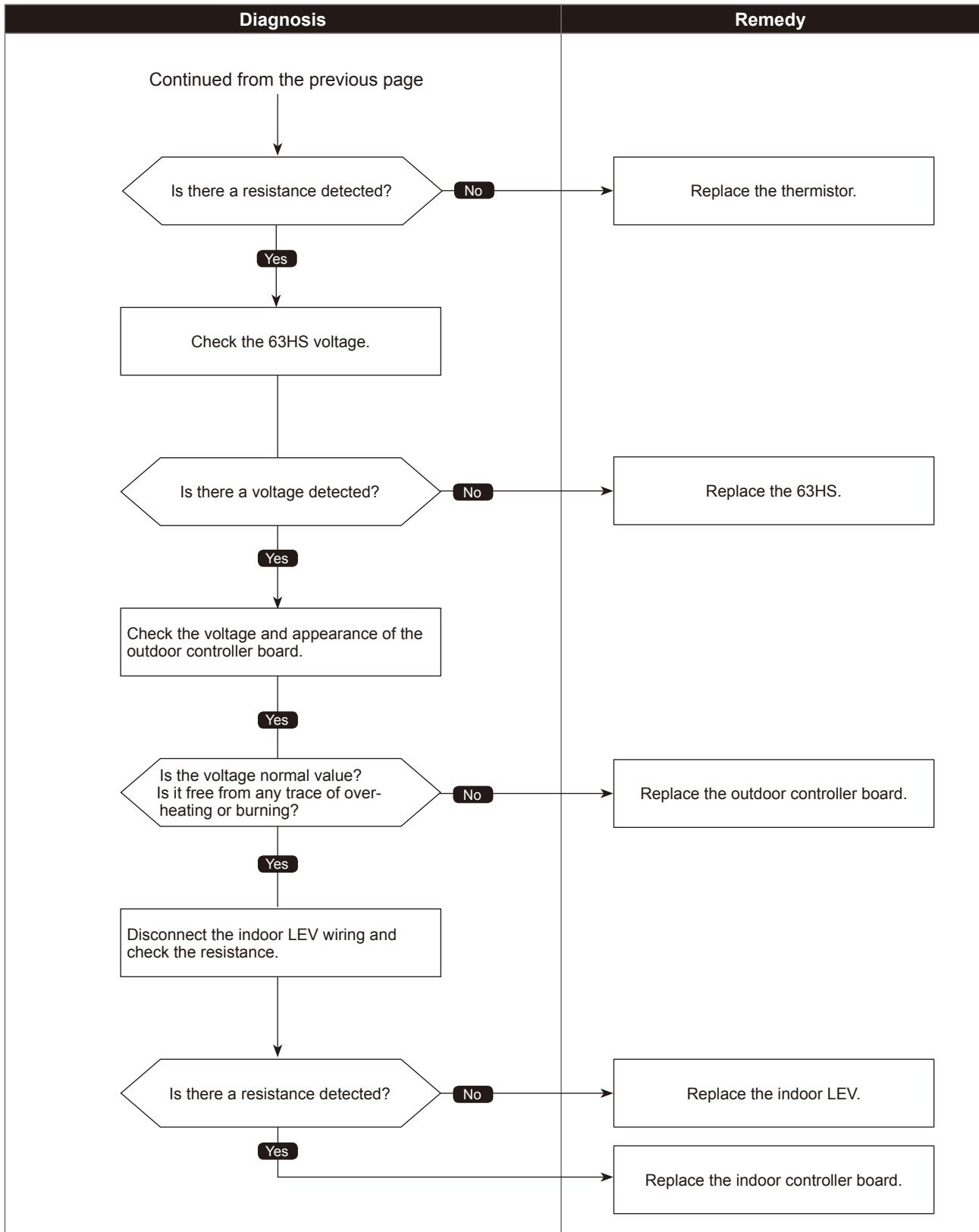

Blocked valve in cooling mode

Abnormal points and detection methods	Causes and check points
<p>Abnormal if stop valve is blocked during cooling operation.</p> <p>Abnormal when both of the following temperature condition is satisfied for 20 minutes or more during cooling operation.</p> <ol style="list-style-type: none"> 1. TH22j - TH21j \geq -2 °C 2. TH23j - TH21j \geq -2 °C <p>Note: For indoor unit, the abnormality is detected if an operating unit satisfies the condition.</p>	<p>① Outdoor liquid/gas valve is blocked.</p> <p>② Multifunction of outdoor LEV (LEV1)(blockage)</p> <p>TH21: Indoor intake temperature thermistor TH22: Indoor liquid pipe temperature thermistor TH23: Indoor gas pipe temperature thermistor LEV: Electronic expansion valve</p>

●Diagnosis of defectives

Make sure to turn the power OFF before connecting/disconnecting any connectors, or replacing boards.

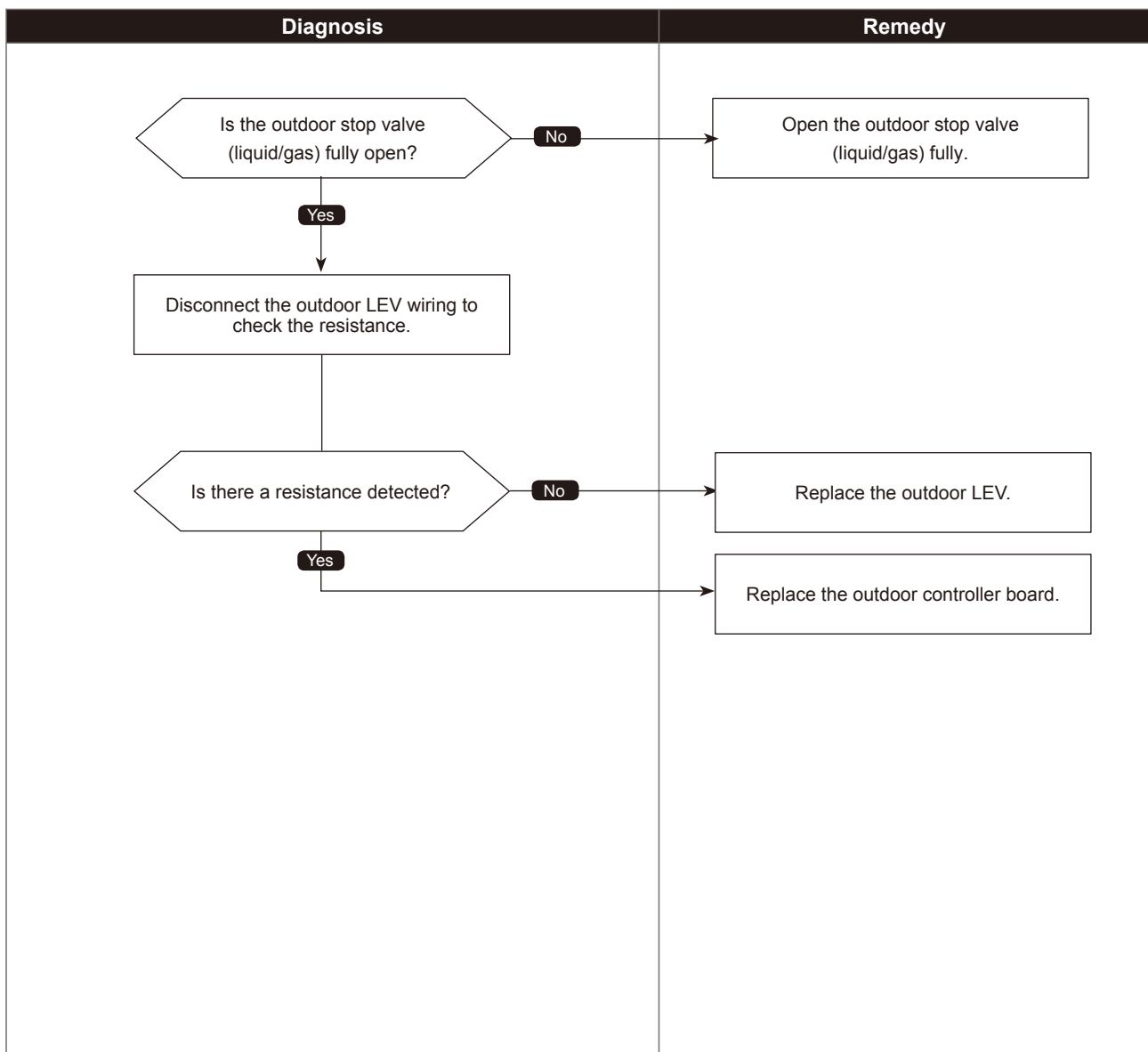

4-way valve trouble in heating mode

Abnormal points and detection methods	Causes and check points
<p>Abnormal if 4-way valve does not operate during heating operation.</p> <p>Abnormal when any of the following temperature condition is satisfied for 3 min. or more during heating operation</p> <ol style="list-style-type: none"> 1. $TH22j - TH21j \geq -10\text{ }^{\circ}\text{C}$ 2. $TH23j - TH21j \geq -10\text{ }^{\circ}\text{C}$ 3. $TH22j \leq 3\text{ }^{\circ}\text{C}$ 4. $TH23j \leq 3\text{ }^{\circ}\text{C}$ <p>Note: For indoor unit, the abnormality is detected if an operating unit satisfies the condition.</p>	<ol style="list-style-type: none"> ① 4-way valve failure ② Disconnection or failure of 4-way valve coil ③ Clogged drain pipe ④ Disconnection or loose connection of connectors ⑤ Malfunction of input circuit on outdoor controller board ⑥ Defective outdoor power board <p>TH21: Indoor intake temperature thermistor TH22: Indoor liquid pipe temperature thermistor TH23: Indoor gas pipe temperature thermistor</p>

●Diagnosis of defectives

Make sure to turn the power OFF before connecting/disconnecting any connectors, or replacing boards.

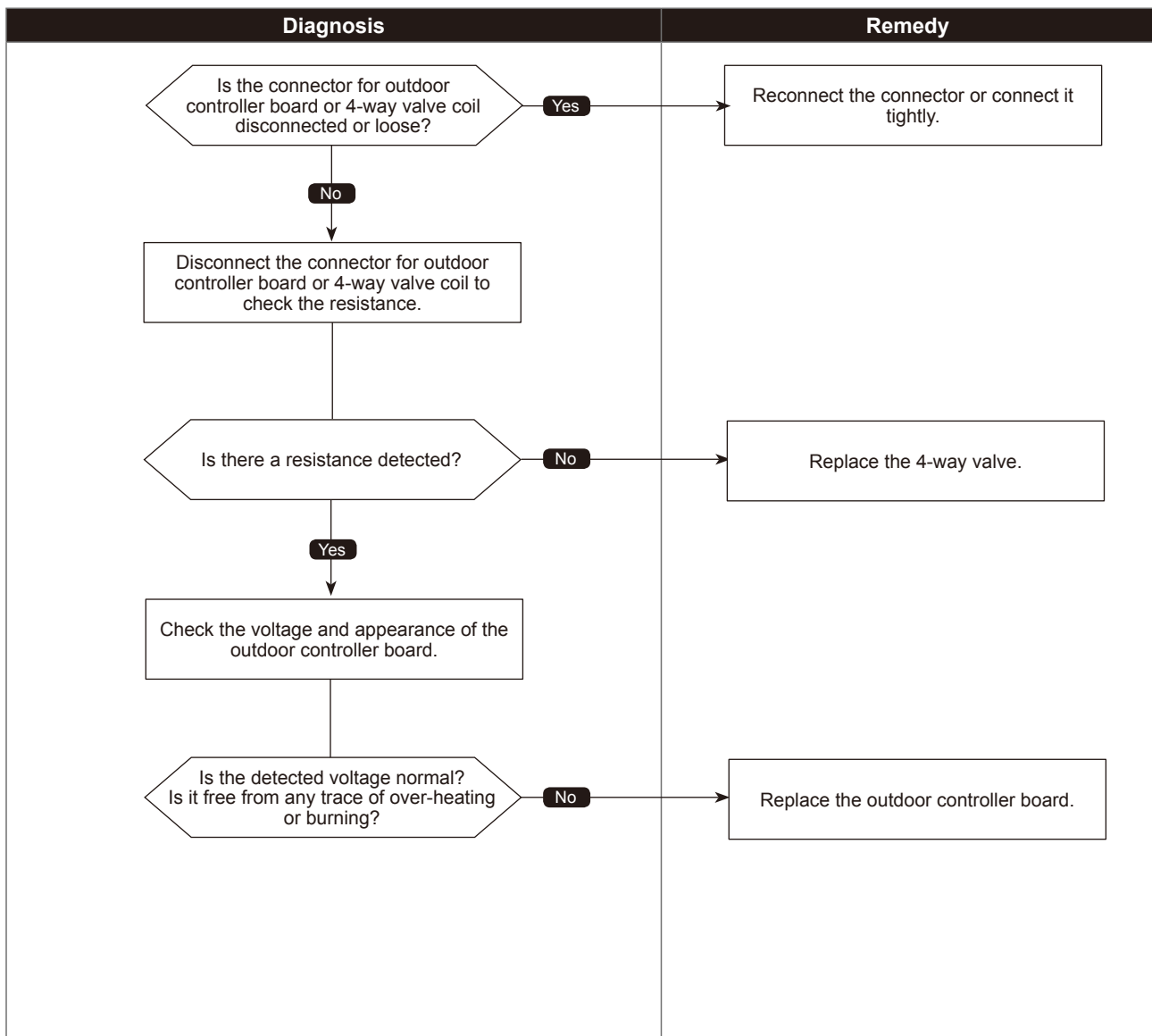

Abnormal points and detection methods	Causes and check points
<p>Abnormal if drain sensor or float switch detects to be in the water during cooling or dry operation.</p> <p>To release this abnormality, reset the power (turn OFF and ON).</p> <p>TH21: Indoor intake temperature thermistor TH22: Indoor liquid pipe temperature thermistor TH23: Indoor gas pipe temperature thermistor</p>	<ul style="list-style-type: none"> ① Reverse connection of extended piping (when connecting multiple units) ② Reverse connection of indoor/ outdoor connector ③ Defective thermistor of TH21 or TH22/23 ④ Defective drain sensor or float switch ⑤ Defective drain pump ⑥ Poor drainage <ul style="list-style-type: none"> · Clogged drain pump · Clogged drain pipe

●Diagnosis of defectives

Make sure to turn the power OFF before connecting/disconnecting any connectors, or replacing boards.

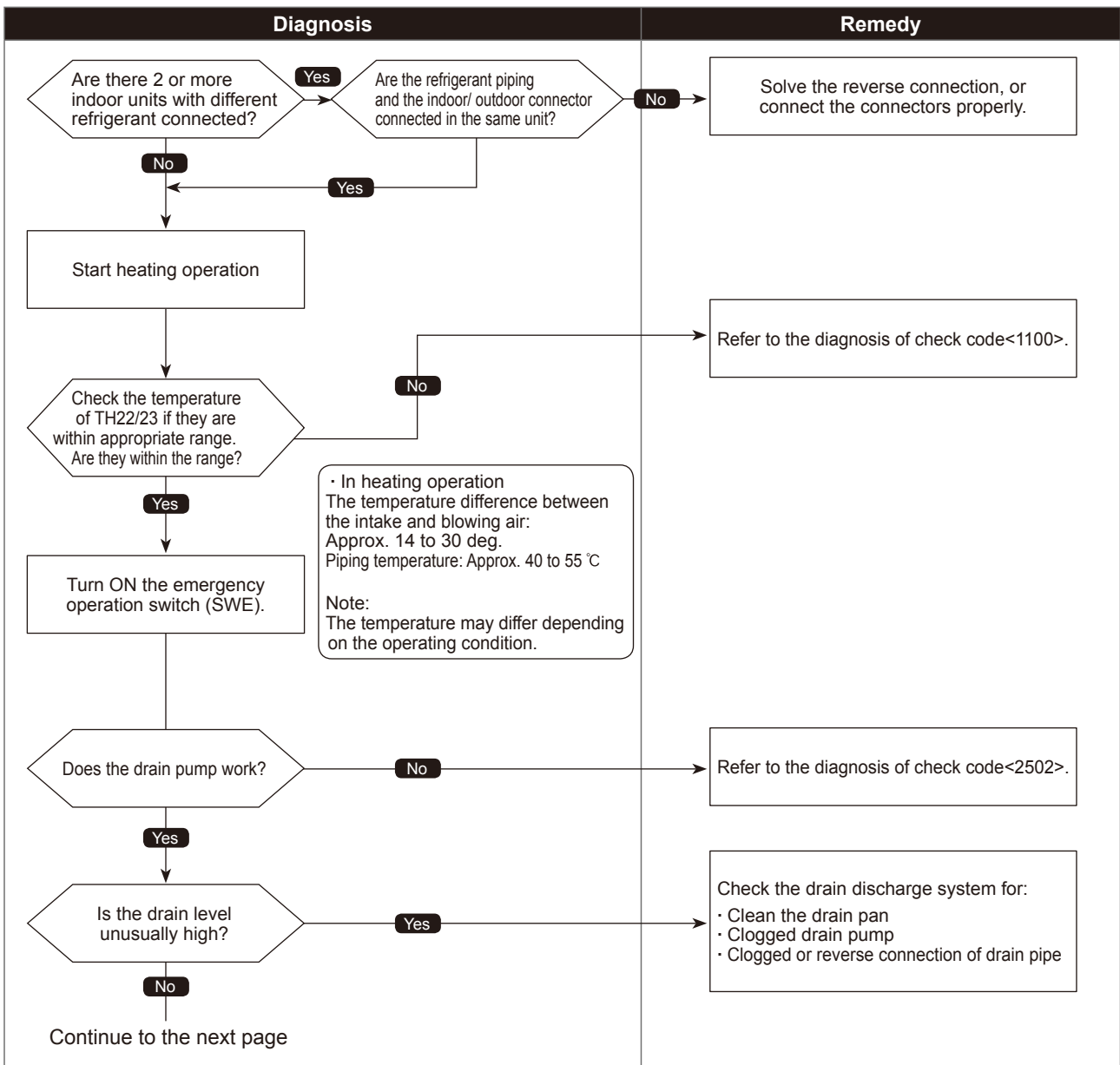

●Diagnosis of defectives

Make sure to turn the power OFF before connecting/disconnecting any connectors, or replacing boards

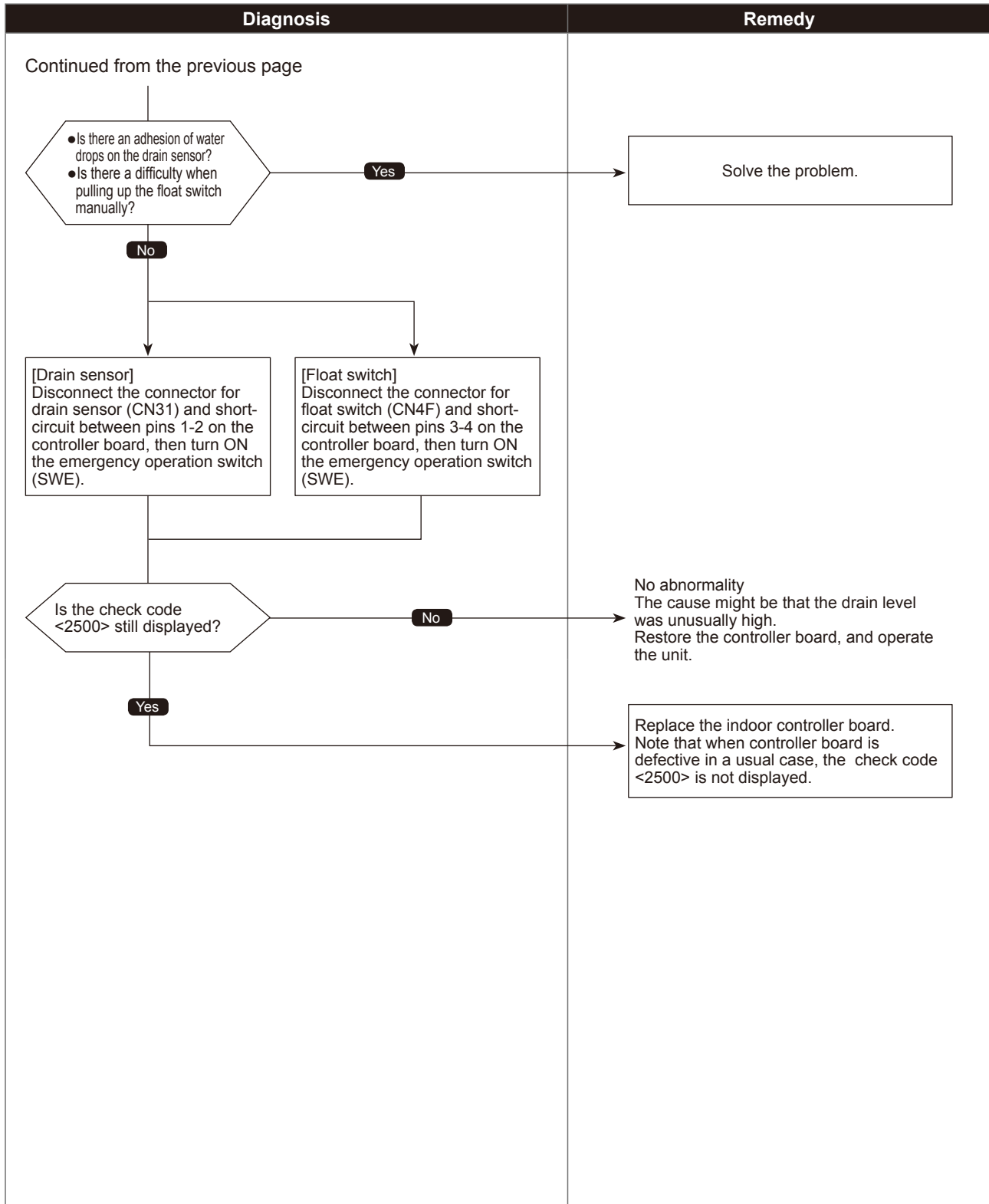

<Drain sensor models> Drain overflow protection

Abnormal points and detection methods	Causes and check points
<p>Drain pump (DP)</p> <p>① Let drain sensor self-heated, and if temperature rises slightly, as suspensive abnormality operation stops and changes to protect mode of restarting in 3 minutes.</p> <p>② Drain pump is abnormal if the condition above is detected during suspensive abnormality. <2502> is displayed.</p> <p>③ Malfunction of drain pipe is constantly detected during drain pump operation.</p> <p>④ The unit enters to forced outdoor unit stop when following conditions, ㉓ and ㉔, are satisfied (while the above mentioned detection is performed).</p> <p>㉓ The drain sensor detects to be soaked in the water 10 times in a row.</p> <p>㉔ Detected that [liquid pipe temperature - room temperature] ≤ -10deg for 30 minutes constantly.</p> <p>Notes:</p> <ol style="list-style-type: none"> When the drain sensor detects to be NOT soaked in the water, the detection record of ㉓ and ㉔ will be cleared.) Drain pump abnormality (above ①-③ is detected before it becomes an outdoor unit forced stop condition). <p>⑤ When indoor unit detects above ④ condition, outdoor unit in the same refrigerant sytem stops. Also, indoor unit except for Fan or OFF mode unit stop. <2502> is displayed on stopped unit.</p> <p>⑥ Detection timing of forced outdoor unit stop Constantly detected during unit operation and stop</p> <p>⑦ Releasing of forced outdoor unit stop Reset power supply of both abnormal indoor unit and its outdoor unit in same refrigerant system. Forced outdoor unit stop cannot be released by remote controller OFF.</p> <p>Note: Above-mentioned ①-③ and ④-⑦ are detected independently.</p>	<p>① Malfunction of drain pump</p> <p>② Defective drain Clogged drain pump Clogged drain pipe</p> <p>③ Water drops on drain sensor Drops of drain trickles from lead wire Clogged filter is causing wave of drain</p> <p>④ Defective indoor controller board</p> <p>⑤ Both of above mentioned ①-④ and the indoor linear expansion valve full-closed failure (leakage) happens synchronistically</p> <p>Note: Address/Attribute displayed on the remote controller shows the indoor unit which is the cause of trouble.</p>

● **Diagnosis of defectives**

Make sure to turn the power OFF before connecting/disconnecting any connectors, or replacing boards.

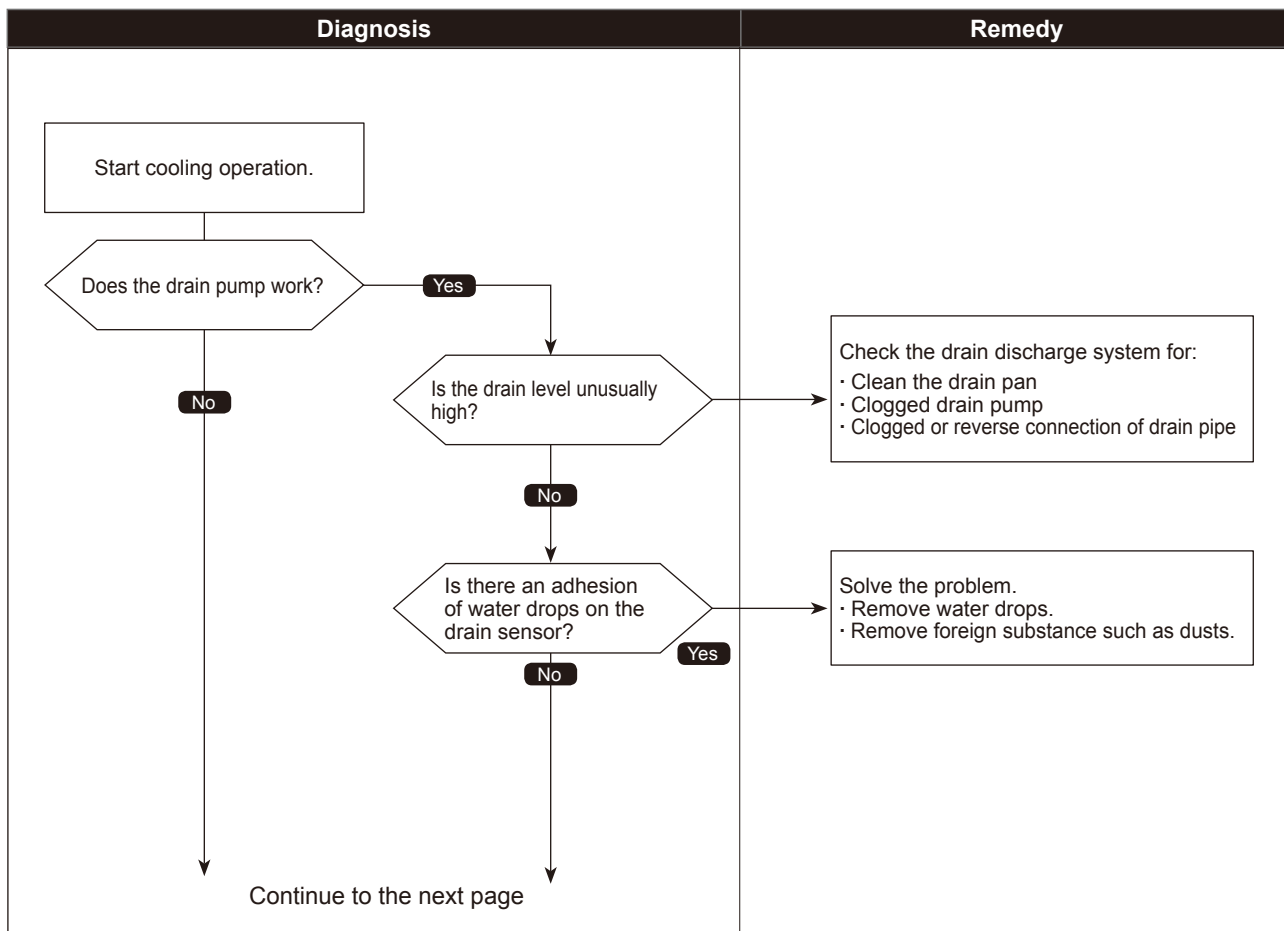

Drain overflow protection

●Diagnosis of defectives

Make sure to turn the power OFF before connecting/disconnecting any connectors, or replacing boards.

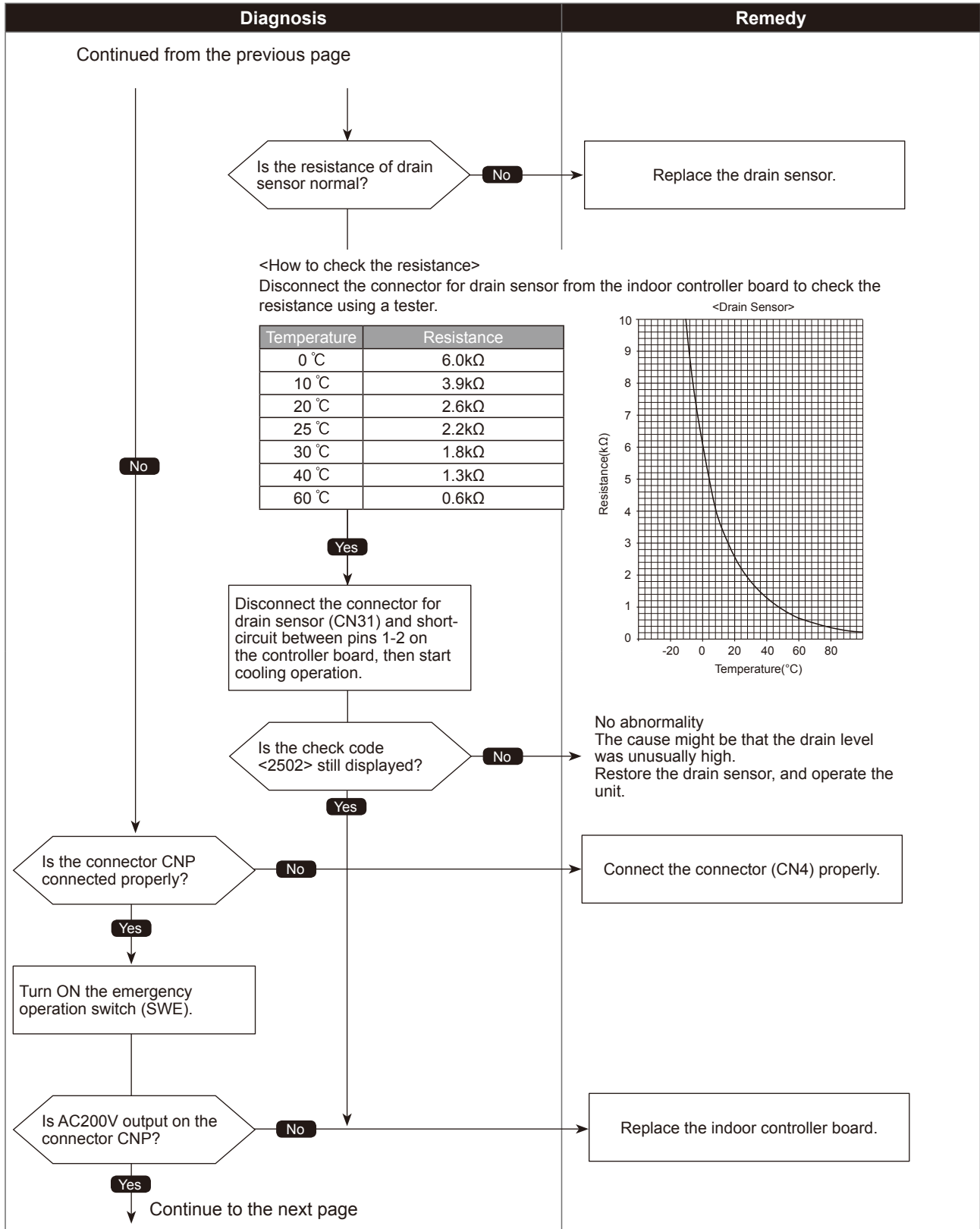

<Drain sensor models>
Drain overflow protection

●Diagnosis of defectives

Make sure to turn the power OFF before connecting/disconnecting any connectors, or replacing boards.

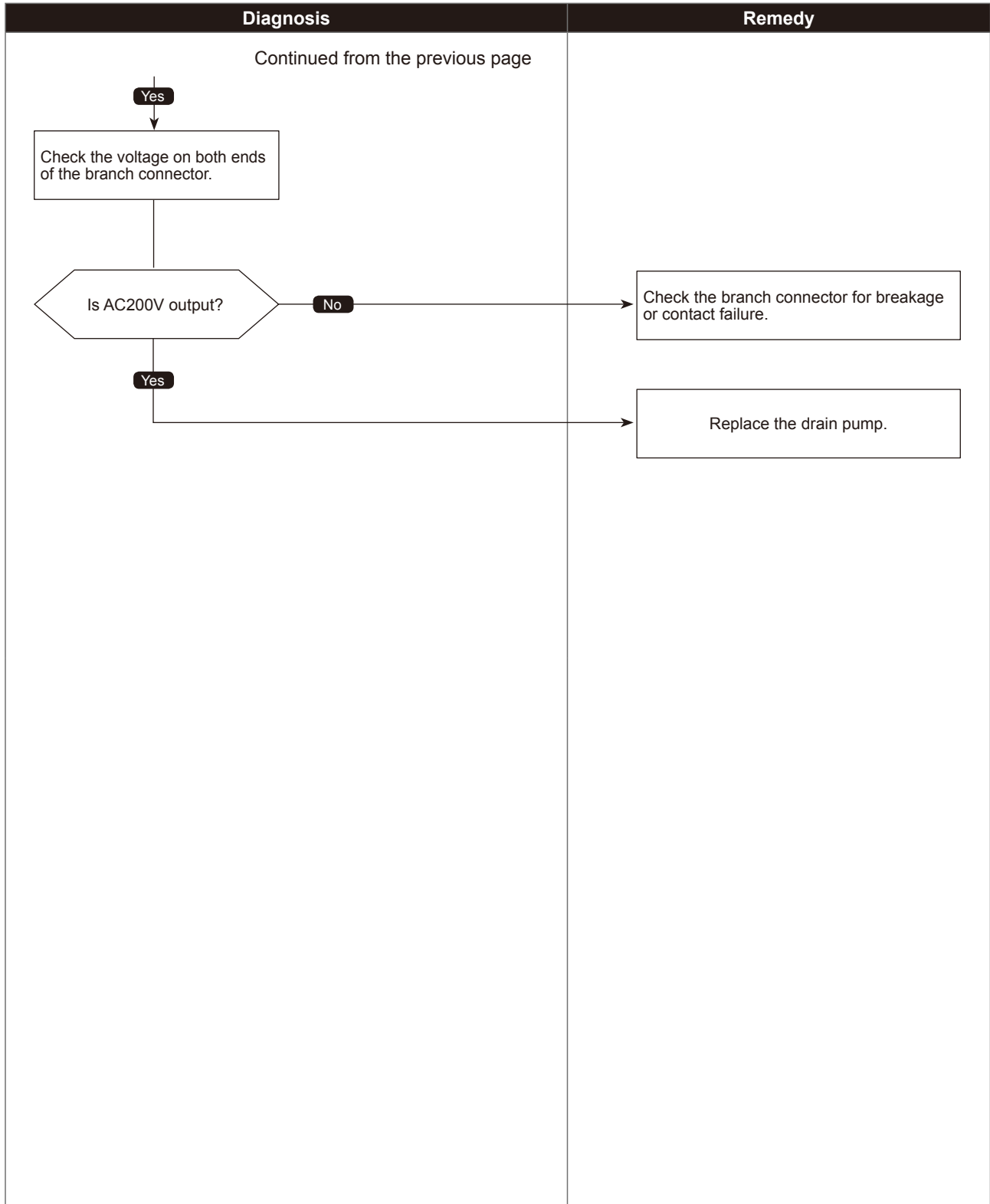

<Float switch models> Drain overflow protection

Abnormal points and detection methods	Causes and check points
<p>Drain pump (DP)</p> <p>① Judge whether the sensor is in the water or in the air by turning the float switch ON/OFF. In the water: Detected that the float switch is ON for 15 seconds. In the air: Detected that the float switch is OFF for 15 seconds.</p> <p>② When the float switch remains to be turned ON for 3 minutes after detected to be in the water, the drain pump is judged to be abnormal and <2502> will be displayed. Note: It takes 3 minutes and 15 seconds to detect abnormality including the time to judge to be in the water.</p> <p>③ The unit continues to detect abnormality while turned off.</p> <p>④ When the conditions below 1, 2 and forced outdoor unit stop condition are met</p> <ol style="list-style-type: none"> 1. Detected that [liquid pipe temperature – room temperature] ≤ [-10deg] for 30 minutes constantly. 2. Float switch detects to be in the water for 15 minutes constantly. <p>Note: Before Forced outdoor unit stop condition is met, the unit always detects ①-③ above.</p> <p>⑤ The indoor unit detecting ④ above stops due to detecting abnormality the outdoor unit in same refrigerant system compressor is inhibited to operate). The unit which stops due to detecting abnormality displays <2502>.</p> <p>⑥ Detection timing of forced outdoor unit stop Constantly detected during unit operation and stop</p> <p>⑦ Releasing of forced outdoor unit stop Reset power supply of both abnormal indoor unit and its outdoor unit in same refrigerant system. Forced outdoor unit stop cannot be released by remote controller OFF.</p> <p>Note: Above-mentioned ①-③ and ④-⑦ are detected independently.</p>	<ol style="list-style-type: none"> ① Malfunction of drain pump ② Defective drain Clogged drain pump Clogged drain pipe ③ Defective moving part of float switch Foreign matter on the moving part of float switch (ex. sludge etc.) ④ Defective float switch ⑤ Defective indoor controller board Defective driving circuit of drain pump Defective input circuit of float switch ⑥ Both of above mentioned 1~5 and the indoor linear expansion valve full-closed failure (leakage) happens synchronistically. <p>Note: Address/Attribute displayed on the remote controller shows the indoor unit which is the cause of trouble.</p>

● Diagnosis of defectives

Make sure to turn the power OFF before connecting/disconnecting any connectors, or replacing boards

Diagnosis	Remedy
<div style="display: flex; justify-content: space-between;"> <div style="width: 60%;"> <pre> graph TD Start[Start cooling operation.] --> Q1{Does the drain pump work?} Q1 -- No --> Next[Continue to the next page] Q1 -- Yes --> Q2{Is the drain level unusually high?} Q2 -- No --> Next Q2 -- Yes --> Remedy[Check the drain discharge system for: · Clean the drain pan · Clogged drain pump · Clogged or reverse connection of drain pipe] </pre> </div> <div style="width: 35%; font-size: small;"> <p>*Please refer to "How to check the parts" on indoor units service manual.</p> </div> </div>	<div style="border: 1px solid black; padding: 5px; margin-top: 20px;"> <p>Check the drain discharge system for:</p> <ul style="list-style-type: none"> · Clean the drain pan · Clogged drain pump · Clogged or reverse connection of drain pipe </div>

<Float switch models> Drain overflow protection

●Diagnosis of defectives

Make sure to turn the power OFF before connecting/disconnecting any connectors, or replacing boards.

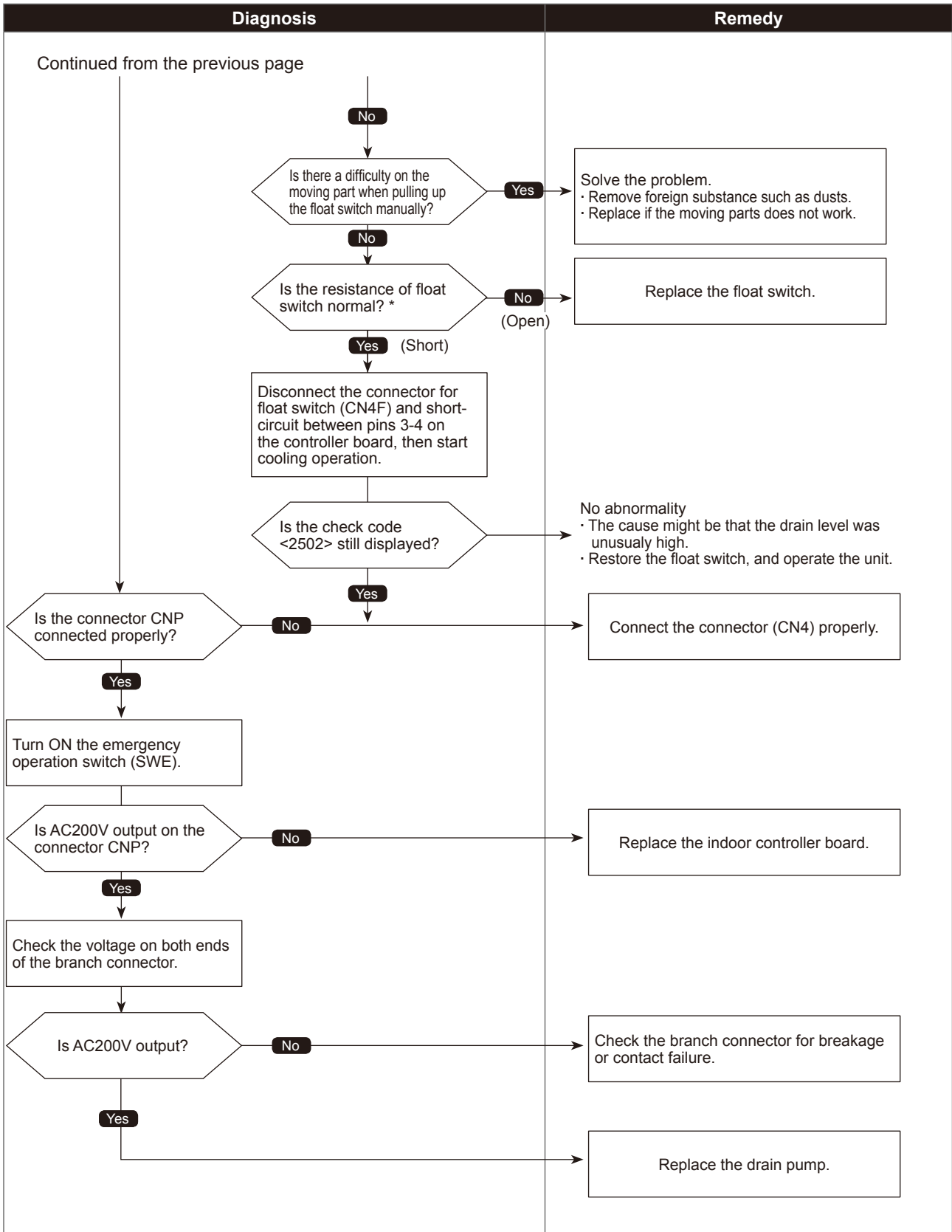

<Drain sensor models> Drain sensor abnormality

Abnormal points and detection methods	Causes and check points
<Drain sensor models> Abnormal if drain sensor detects to be short/ open .	① Contact failure of connector CN31 ② Characteristic defect of thermistor ③ Breakage or contact failure of drain sensor wiring. ④ Replace the indoor controller board.

●Diagnosis of defectives

Make sure to turn the power OFF before connecting/disconnecting any connectors, or replacing boards

Diagnosis	Remedy																
<p style="text-align: center;">[Drain sensor models]</p> <div style="border: 1px solid black; padding: 5px; margin-bottom: 10px;"> Check the drain sensor connector (CN31) for disconnection or looseness. </div> <div style="text-align: center;"> <div style="border: 1px solid black; width: 150px; height: 30px; margin: 0 auto; display: flex; align-items: center; justify-content: center;"> Is it connected normally? </div> <div style="display: flex; justify-content: space-around; margin-top: 5px;"> <div style="border: 1px solid black; padding: 2px 5px;">No</div> <div style="border: 1px solid black; padding: 2px 5px;">Yes</div> </div> </div> <div style="margin-top: 20px;"> <div style="border: 1px solid black; width: 150px; height: 30px; margin: 0 auto; display: flex; align-items: center; justify-content: center;"> Is the resistance of thermistor normal? </div> <div style="display: flex; justify-content: space-around; margin-top: 5px;"> <div style="border: 1px solid black; padding: 2px 5px;">No</div> <div style="border: 1px solid black; padding: 2px 5px;">Yes</div> </div> </div>	<div style="border: 1px solid black; padding: 5px; margin-bottom: 20px;"> Connect it properly. Turn the power back ON, then check the operation. </div> <div style="border: 1px solid black; padding: 5px; margin-bottom: 20px; text-align: center;"> Replace the drain sensor. </div> <div style="border: 1px solid black; padding: 5px; text-align: center;"> Replace the indoor controller board. </div>																
<p><How to check the resistance> Disconnect the connector for drain sensor from the indoor controller board to check the resistance using a tester.</p> <table border="1" style="width: 100%; border-collapse: collapse; margin-bottom: 10px;"> <thead> <tr style="background-color: #cccccc;"> <th style="text-align: center;">Temperature</th> <th style="text-align: center;">Resistance</th> </tr> </thead> <tbody> <tr><td style="text-align: center;">0 °C</td><td style="text-align: center;">6.0kΩ</td></tr> <tr><td style="text-align: center;">10 °C</td><td style="text-align: center;">3.9kΩ</td></tr> <tr><td style="text-align: center;">20 °C</td><td style="text-align: center;">2.6kΩ</td></tr> <tr><td style="text-align: center;">25 °C</td><td style="text-align: center;">2.2kΩ</td></tr> <tr><td style="text-align: center;">30 °C</td><td style="text-align: center;">1.8kΩ</td></tr> <tr><td style="text-align: center;">40 °C</td><td style="text-align: center;">1.3kΩ</td></tr> <tr><td style="text-align: center;">60 °C</td><td style="text-align: center;">0.6kΩ</td></tr> </tbody> </table> <div style="text-align: right;"> <p style="font-size: small;"><Drain Sensor></p> </div>		Temperature	Resistance	0 °C	6.0kΩ	10 °C	3.9kΩ	20 °C	2.6kΩ	25 °C	2.2kΩ	30 °C	1.8kΩ	40 °C	1.3kΩ	60 °C	0.6kΩ
Temperature	Resistance																
0 °C	6.0kΩ																
10 °C	3.9kΩ																
20 °C	2.6kΩ																
25 °C	2.2kΩ																
30 °C	1.8kΩ																
40 °C	1.3kΩ																
60 °C	0.6kΩ																

Compressor current interruption (Locked compressor)

Abnormal points and detection methods	Causes and check points
Abnormal if overcurrent of DC bus or compressor is detected 30 seconds after the compressor starts operating.	<ul style="list-style-type: none"> ① Closed stop valve ② Decrease of power supply voltage ③ Looseness, disconnection or converse of compressor wiring connection ④ Model selection error upon replacement of indoor controller board ⑤ Defective compressor ⑥ Defective outdoor power board

●Diagnosis of defectives

Make sure to turn the power OFF before connecting/disconnecting any connectors, or replacing boards.

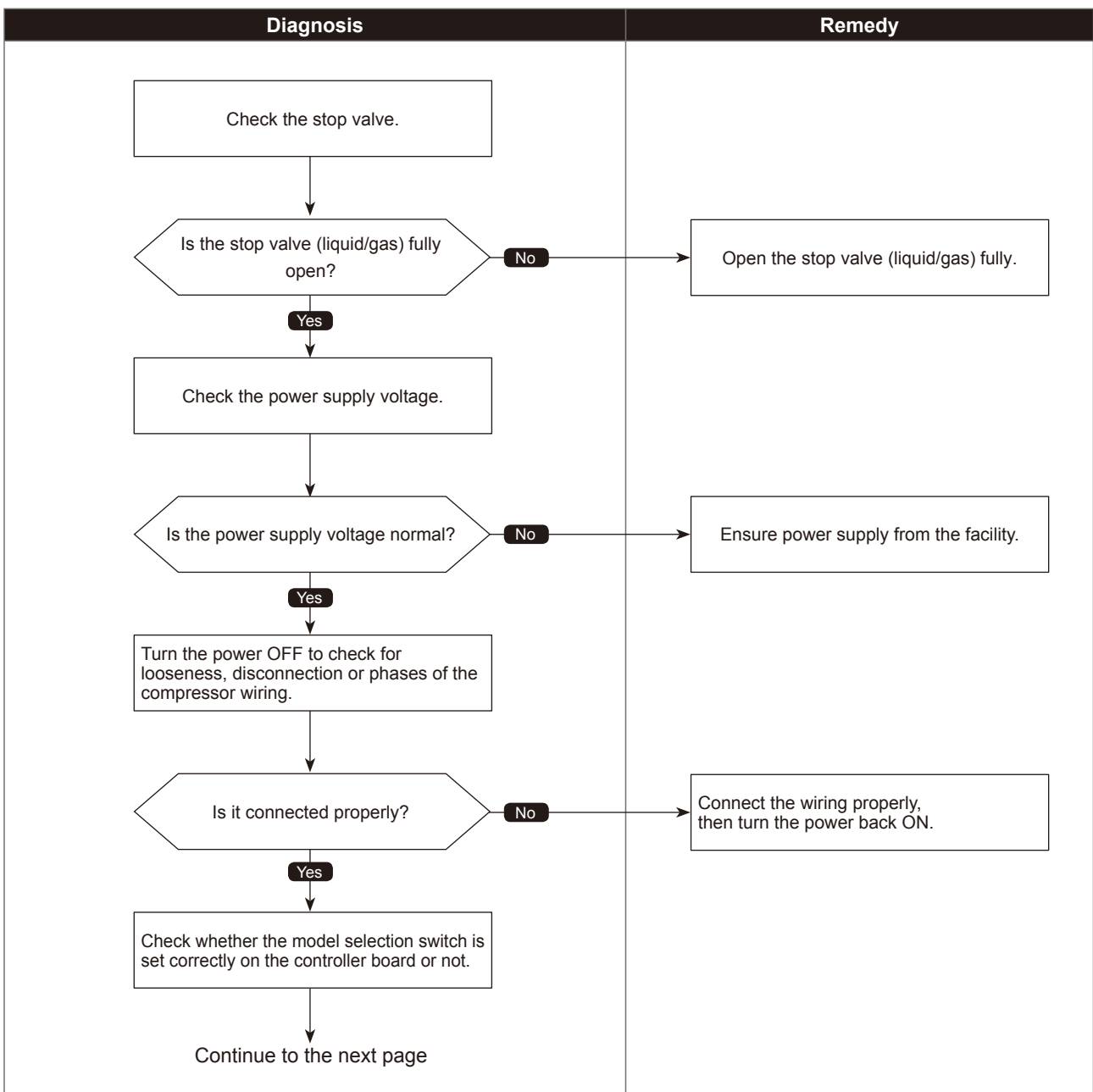

●Diagnosis of defectives

Make sure to turn the power OFF before connecting/disconnecting any connectors, or replacing boards.

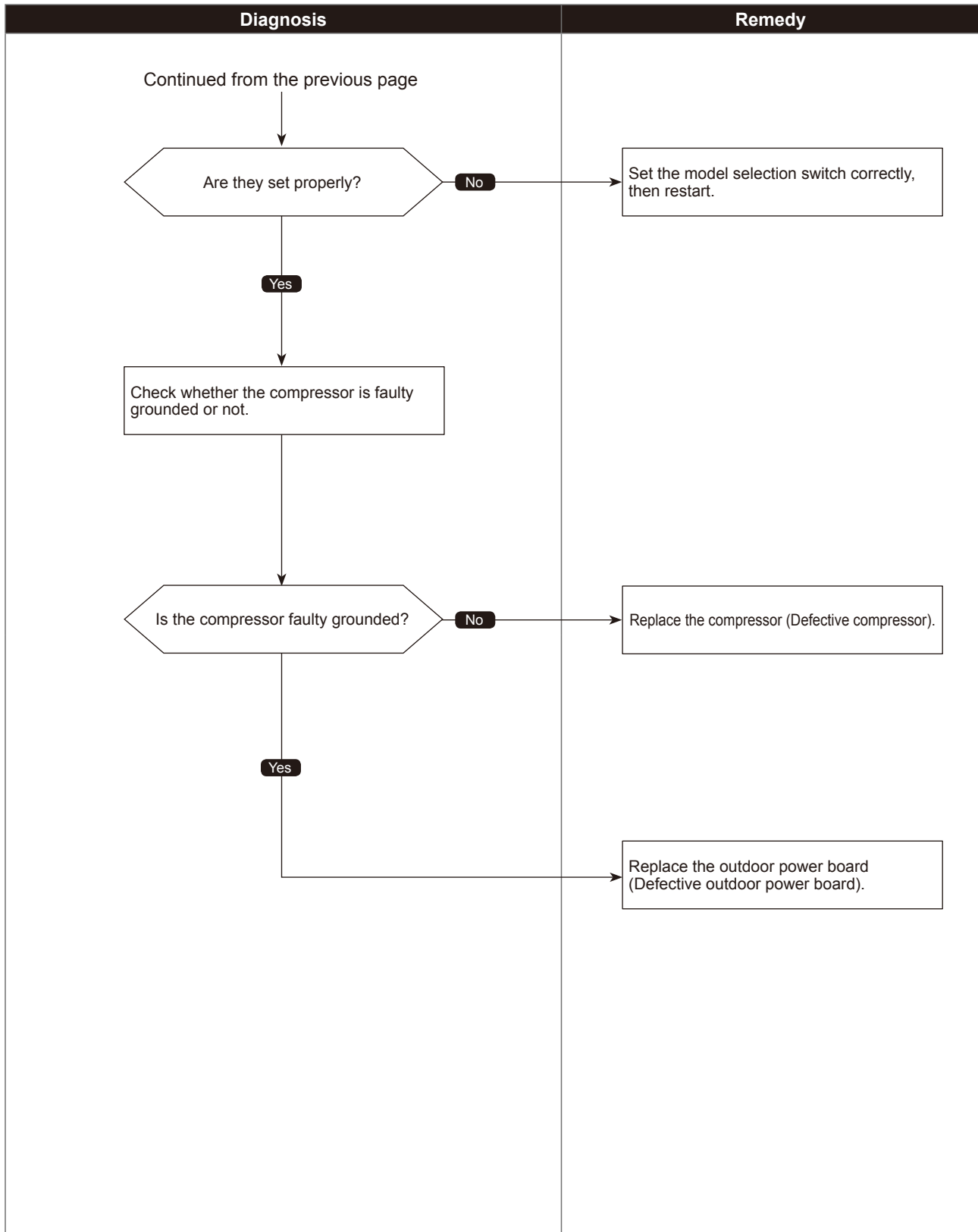

Compressor overcurrent interruption

Abnormal points and detection methods	Causes and check points
Abnormal if overcurrent of DC or the compressor is detected within 30 seconds after the compressor starts operating.	<ul style="list-style-type: none"> ① Closed outdoor stop valve ② Decrease of power supply voltage ③ Looseness, disconnection or reverse phase of compressor wiring connection ④ Malfunction of indoor/outdoor fan ⑤ Short-cycle of indoor/outdoor unit ⑥ Model selection error upon replacement of outdoor controller board ⑦ Malfunction of input circuit on outdoor controller board ⑧ Defective compressor ⑨ Defective outdoor power board

●Diagnosis of defectives

Make sure to turn the power OFF before connecting/disconnecting any connectors, or replacing boards.

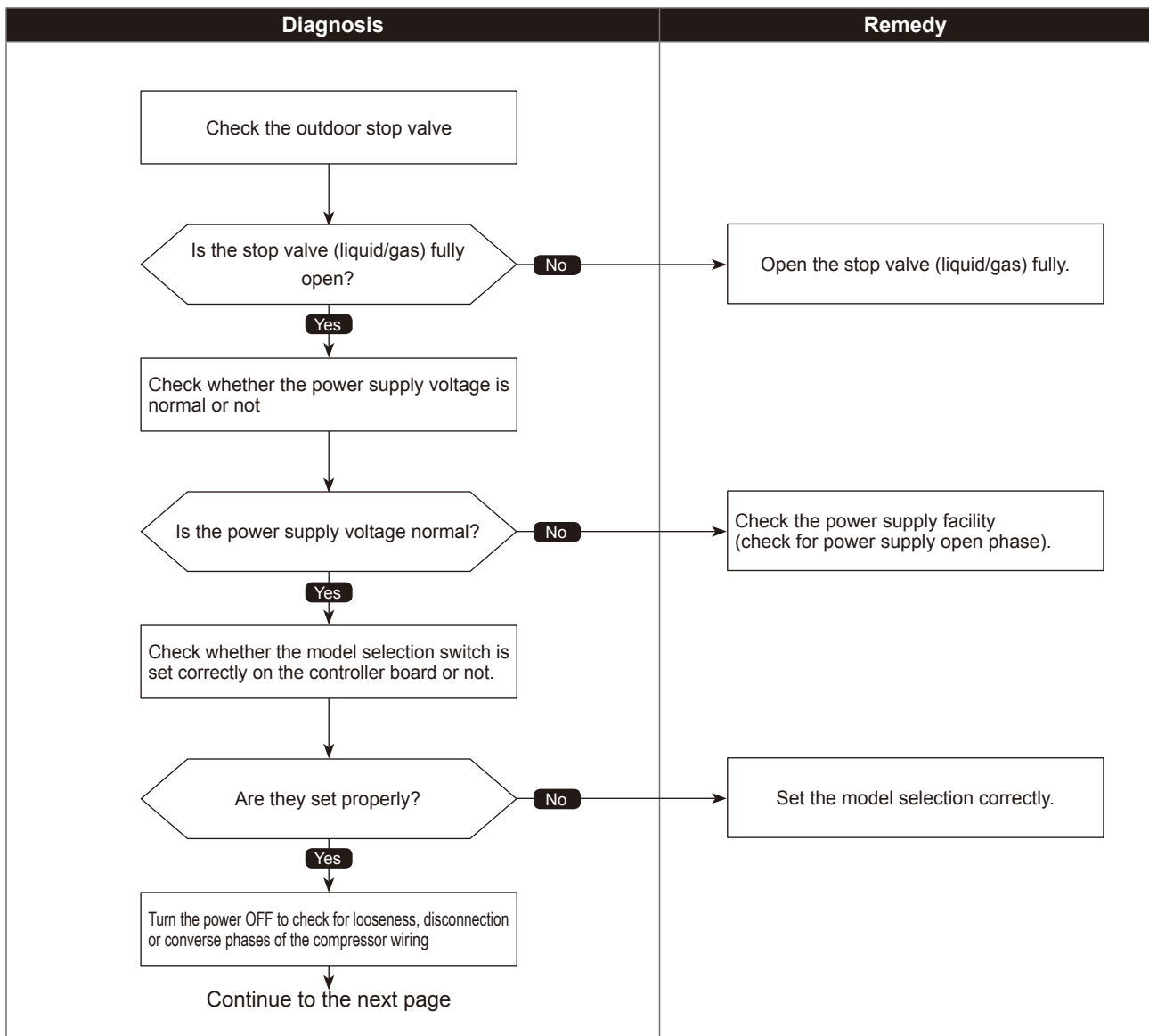

Compressor overcurrent interruption

●Diagnosis of defectives

Make sure to turn the power OFF before connecting/disconnecting any connectors, or replacing boards.

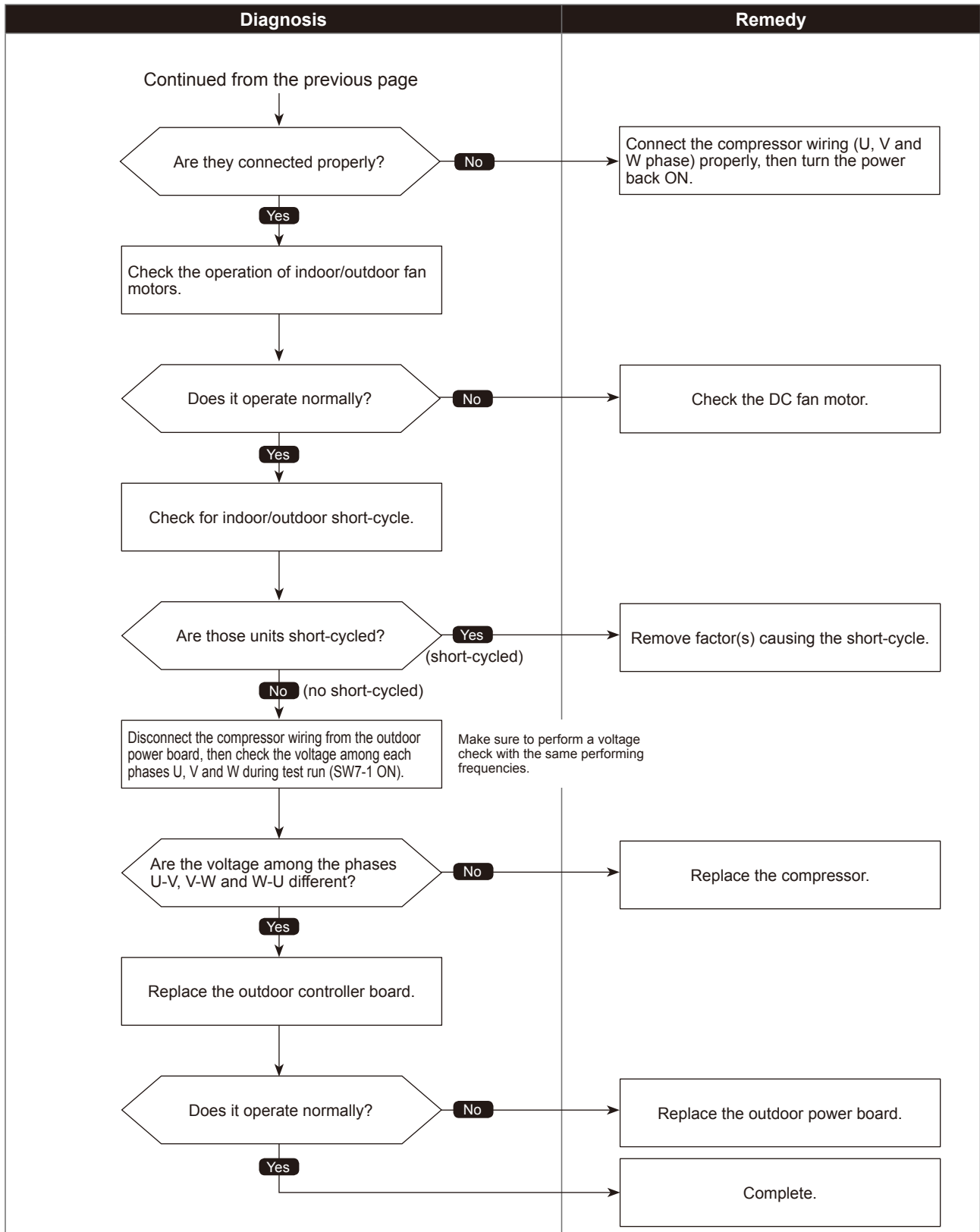

Voltage shortage/Overvoltage/PAM error/L1 open-phase/ Power synchronization signal error

Abnormal points and detection methods	Causes and check points
<p>Abnormal if any of following symptoms are detected;</p> <p>① P112/125/140V model</p> <ul style="list-style-type: none"> ● Decrease of DC bus voltage to 200V ● Increase of DC bus voltage to 400V ● DC bus voltage stays at 310V or lower for consecutive 10 seconds <p>② P112/125/140Y model</p> <ul style="list-style-type: none"> ● Decrease of DC bus voltage to 350V ● Increase of DC bus voltage to 760V ● Decrease of primary current to 0.1A <p>Note: The detection is active only when the operational frequency is 40Hz or more, or the compressor current is 6A or more.</p>	<ul style="list-style-type: none"> ① Decrease/increase of power supply voltage, or T open-phase ② Disconnection of compressor wiring ③ Malfunction of 52C ④ Disconnection or contact failure of CN52C ⑤ Defective outdoor power board ⑥ Malfunction of 52C driving circuit on outdoor controller board ⑦ Disconnection of CN5 ⑧ Disconnection of CN2 ⑨ Malfunction of primary current detecting circuit on outdoor power board

● **Diagnosis of defectives**

Make sure to turn the power OFF before connecting/disconnecting any connectors, or replacing boards.

The black square (■) indicates a switch position.

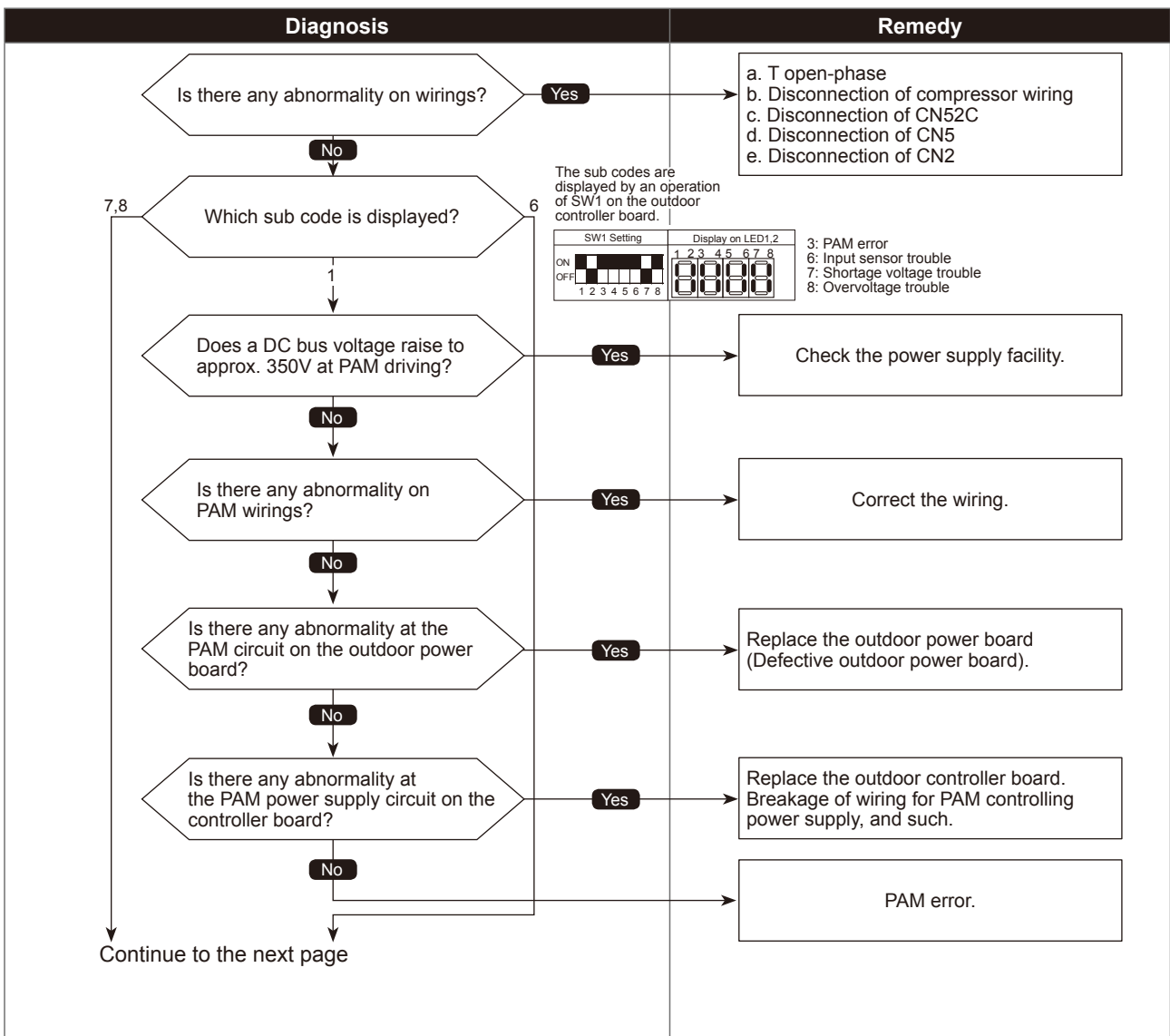

Voltage shortage/Overvoltage/PAM error/L1 open-phase/ Power synchronization signal error

●Diagnosis of defectives

Make sure to turn the power OFF before connecting/disconnecting any connectors, or replacing boards.

The black square (■) indicates a switch position.

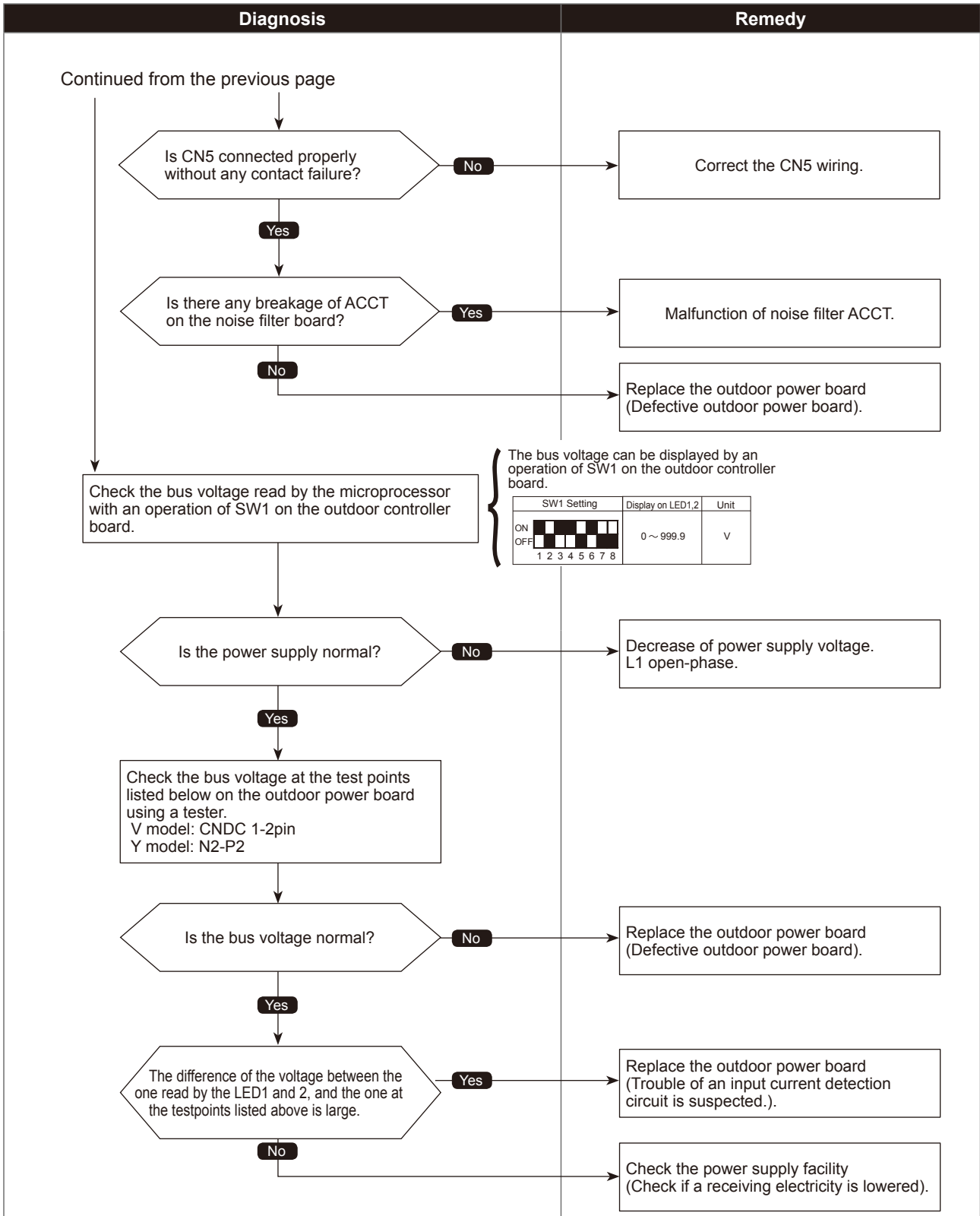

Heat Sink temperature trouble

Abnormal points and detection methods	Causes and check points
<p>Abnormal if TH8 detects a temperature outside the specified range during compressor operation.</p> <p>TH8: Thermistor <Heat Sink></p>	<ul style="list-style-type: none"> ① Blocked outdoor fan ② Malfunction of outdoor fan motor ③ Blocked airflow path ④ Rise of ambient temperature ⑤ Characteristic defect of thermistor ⑥ Malfunction of input circuit on outdoor power board ⑦ Malfunction of outdoor fan driving circuit

●Diagnosis of defectives

Make sure to turn the power OFF before connecting/disconnecting any connectors, or replacing boards.

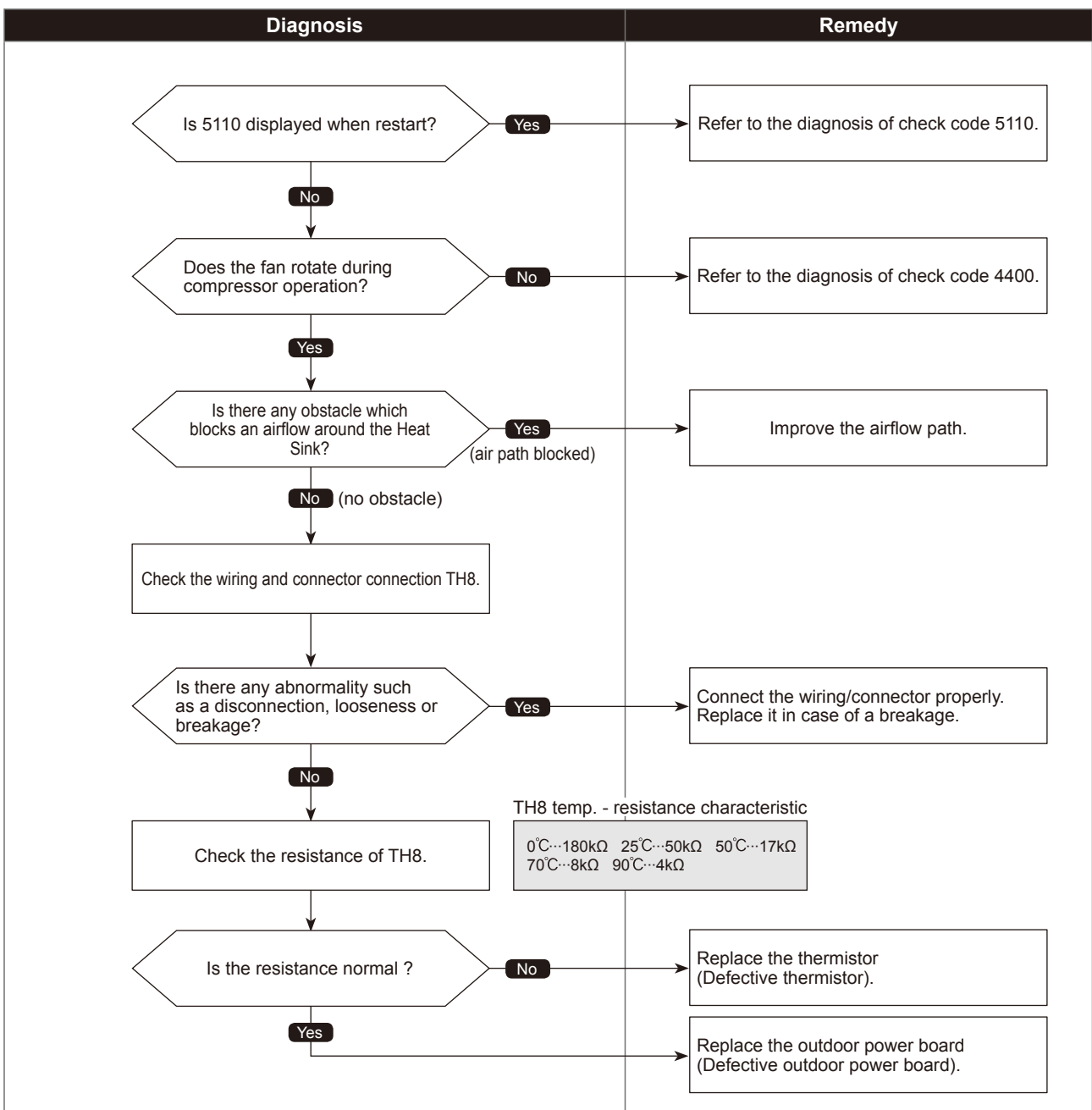

Power module trouble

Abnormal points and detection methods	Causes and check points
Abnormal if overcurrent of DC bus or compressor is detected 30seconds after the compressor starts operating. To determine the source of abnormality, either the compressor or the power module, drive the power module forcedly.	<ul style="list-style-type: none"> ① Closed outdoor stop valve ② Decrease of power supply voltage ③ Disconnection, looseness or conversed connection of compressor wiring ④ Defective compressor ⑤ Defective outdoor power board

●Diagnosis of defectives

Make sure to turn the power OFF before connecting/disconnecting any connectors, or replacing boards.

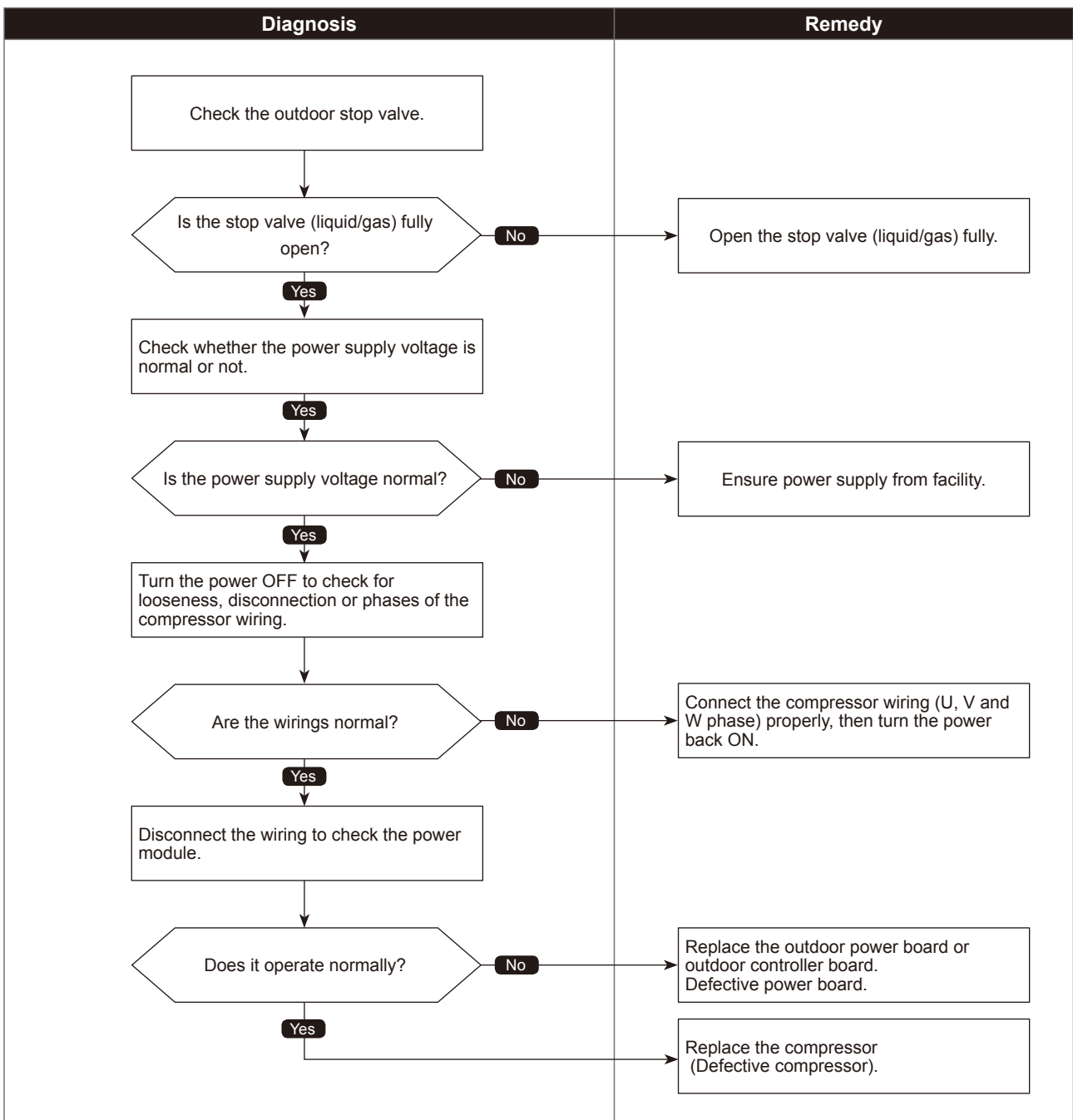

Rotational frequency of outdoor fan motor trouble

Abnormal points and detection methods	Causes and check points
Abnormal if no rotational frequency is detected, or detected a value outside the specified range during fan motor operation.	① Malfunction of fan motor ② Disconnection of CNF connector ③ Defective outdoor controller board

●Diagnosis of defectives

Make sure to turn the power OFF before connecting/disconnecting any connectors, or replacing boards.

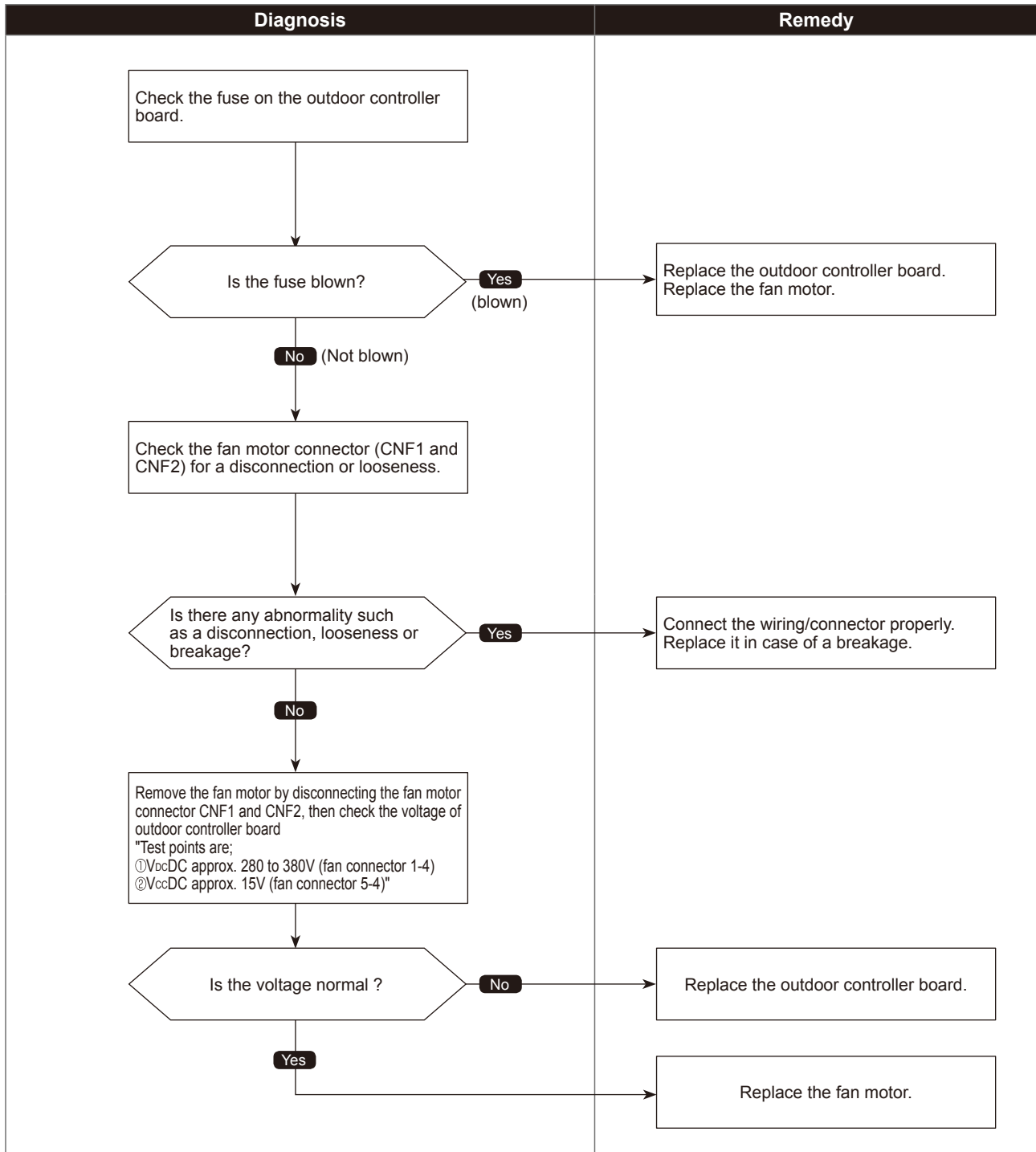

Compressor temperature thermistor (TH4) open/short

<Detected in outdoor unit>

Abnormal points and detection methods	Causes and check points
Abnormal if TH4 detects to be open/short. (The open/short detection is disabled for 10 minutes after compressor starts, during defrosting operation, or for 10 minutes after returning from the defrosting operation.) Open: 3 °C or less Short: 217 °C or more TH4: Thermistor <Compressor>	① Disconnection or contact failure of connectors ② Characteristic defect of thermistor ③ Defective outdoor controller board

●Diagnosis of defectives

Make sure to turn the power OFF before connecting/disconnecting any connectors, or replacing boards.

The black square (■) indicates a switch position.

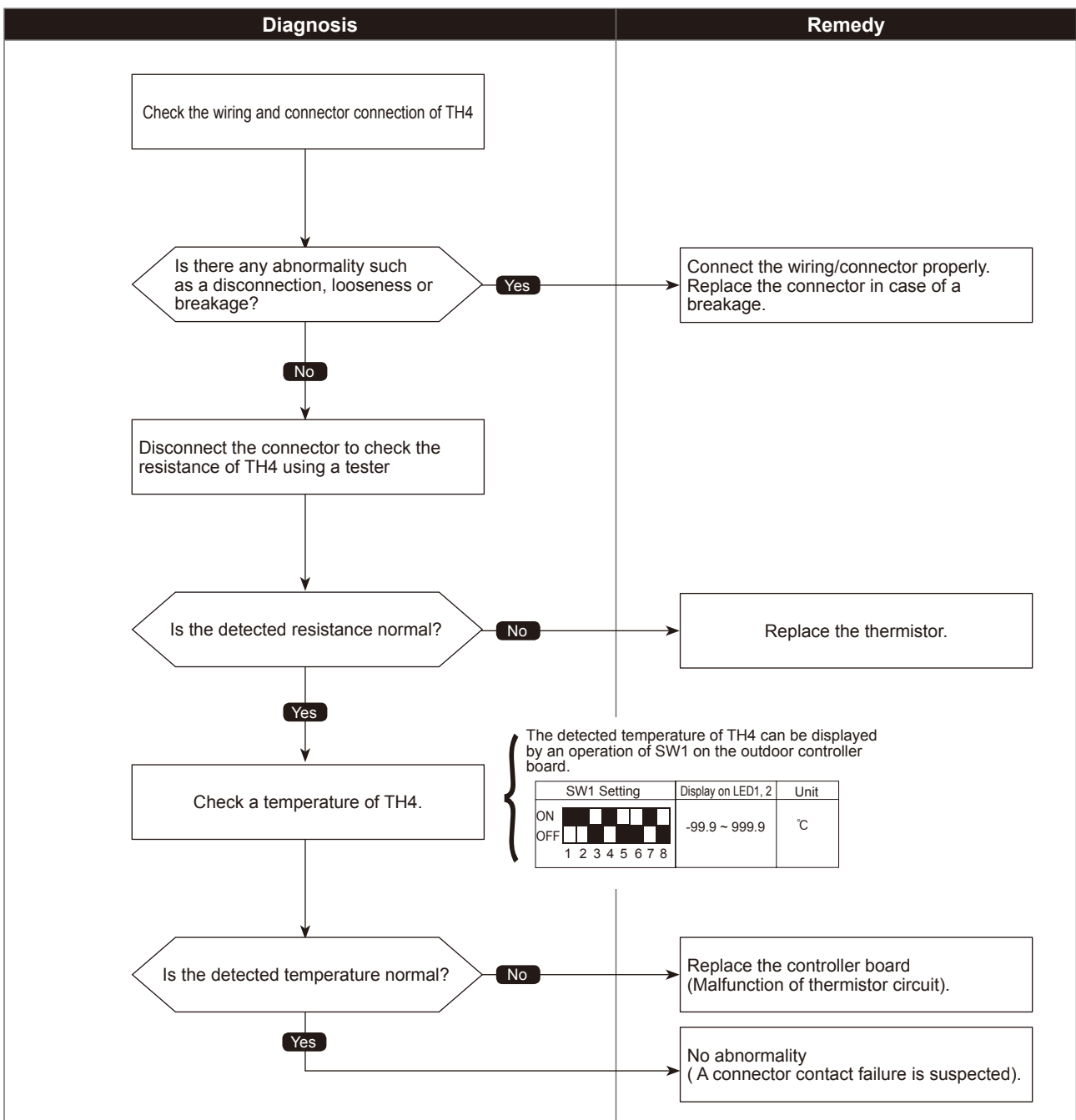

Suction pipe temperature thermistor (TH6) open/short

<Detected in outdoor unit>

Abnormal points and detection methods	Causes and check points
Abnormal if TH6 detects to be open/short. (The open/short detection is disabled during 10 sec. to 10 min. after compressor starts, during defrosting operation, or for 10 min. after returning from the defrosting operation.) Open: -40 °C or less Short: 90 °C or more TH6: Thermistor <Suction pipe>	① Disconnection or contact failure of connectors ② Characteristic defect of thermistor ③ Defective outdoor controller board

●Diagnosis of defectives

Make sure to turn the power OFF before connecting/disconnecting any connectors, or replacing boards.

The black square (■) indicates a switch position.

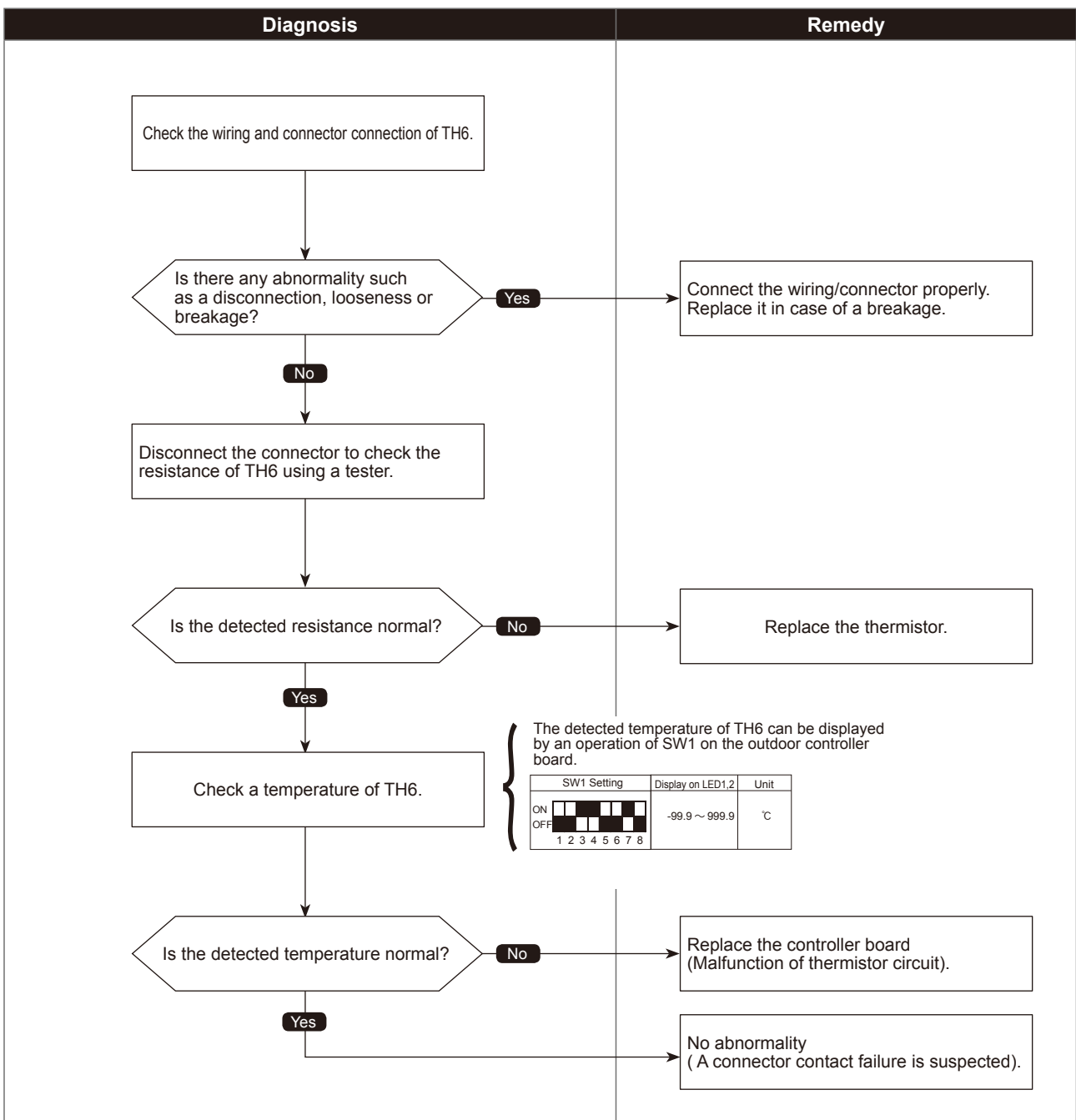

Check code

5101, 5102, 5103

Air inlet thermistor trouble (TH21) Liquid pipe temperature thermistor trouble (TH22) Gas pipe temperature thermistor trouble (TH23)

<Detected in indoor unit>

Abnormal points and detection methods	Causes and check points
Abnormal if any of the following thermistor detected to be open/ short. TH21: Air inlet thermistor TH22: Liquid pipe temperature thermistor TH23: Gas pipe temperature thermistor	① Contact failure of connectors ② Characteristic defect of thermistor ③ Disconnection or contact failure of thermistor ④ Defective indoor controller board

●Diagnosis of defectives

Make sure to turn the power OFF before connecting/disconnecting any connectors, or replacing boards.

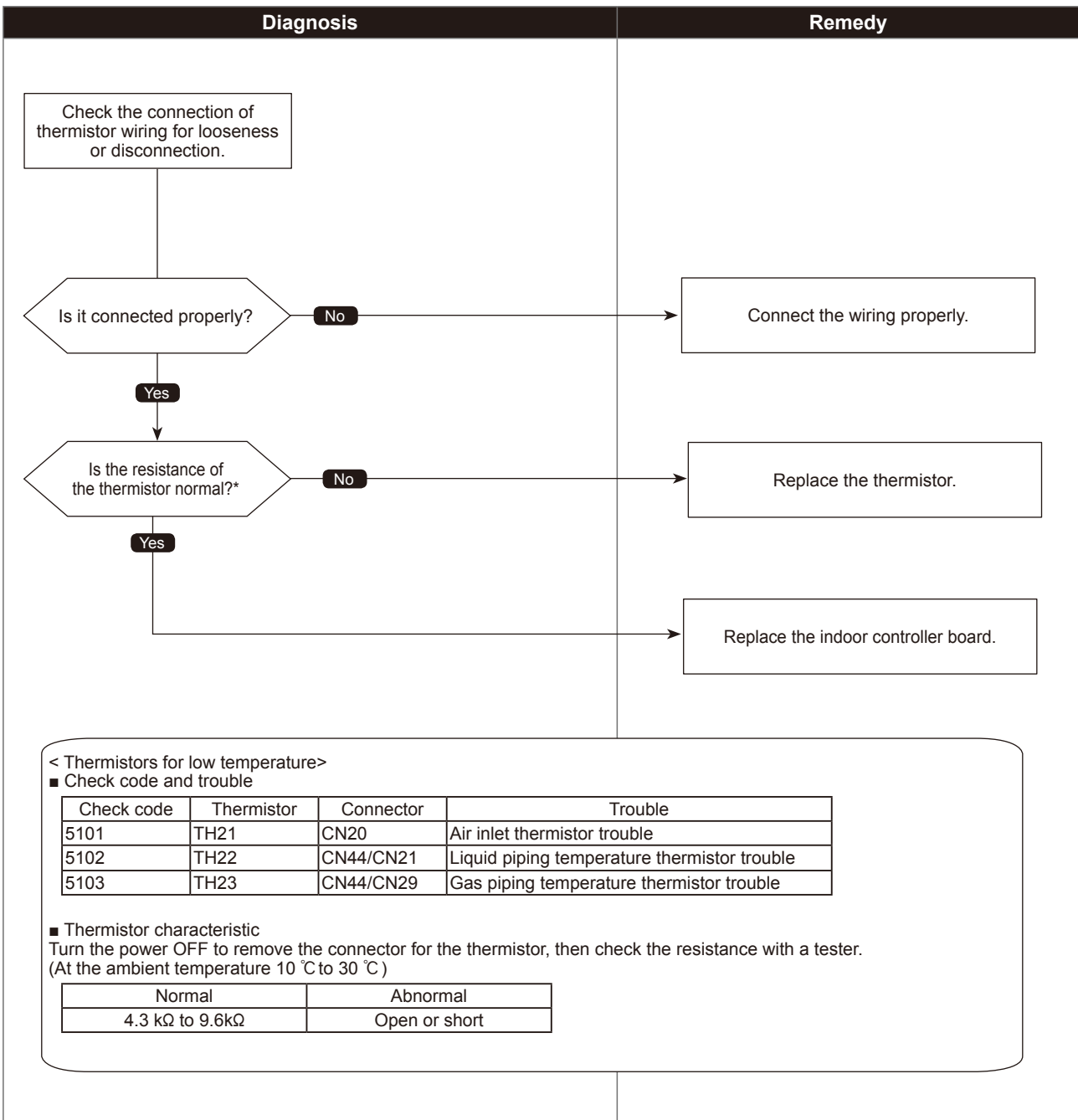

* Symbols for thermistors and connectors may be different depending on the model. Please refer to its wiring diagram.

Outdoor liquid pipe temperature thermistor (TH3) open/short

Abnormal points and detection methods	Causes and check points
Abnormal if TH3 detects to be open/short. (The open/short detection is disabled during 10 sec. to 10 min. after compressor starts, during defrosting operation, or for 10 min. after returning from the defrosting operation.) Open: -40 °C or less Short: 90 °C or more TH3: Thermistor <Outdoor liquid pipe>	① Disconnection or contact failure of connectors ② Characteristic defect of thermistor ③ Defective outdoor controller board

●Diagnosis of defectives

Make sure to turn the power OFF before connecting/disconnecting any connectors, or replacing boards.

The black square (■) indicates a switch position.

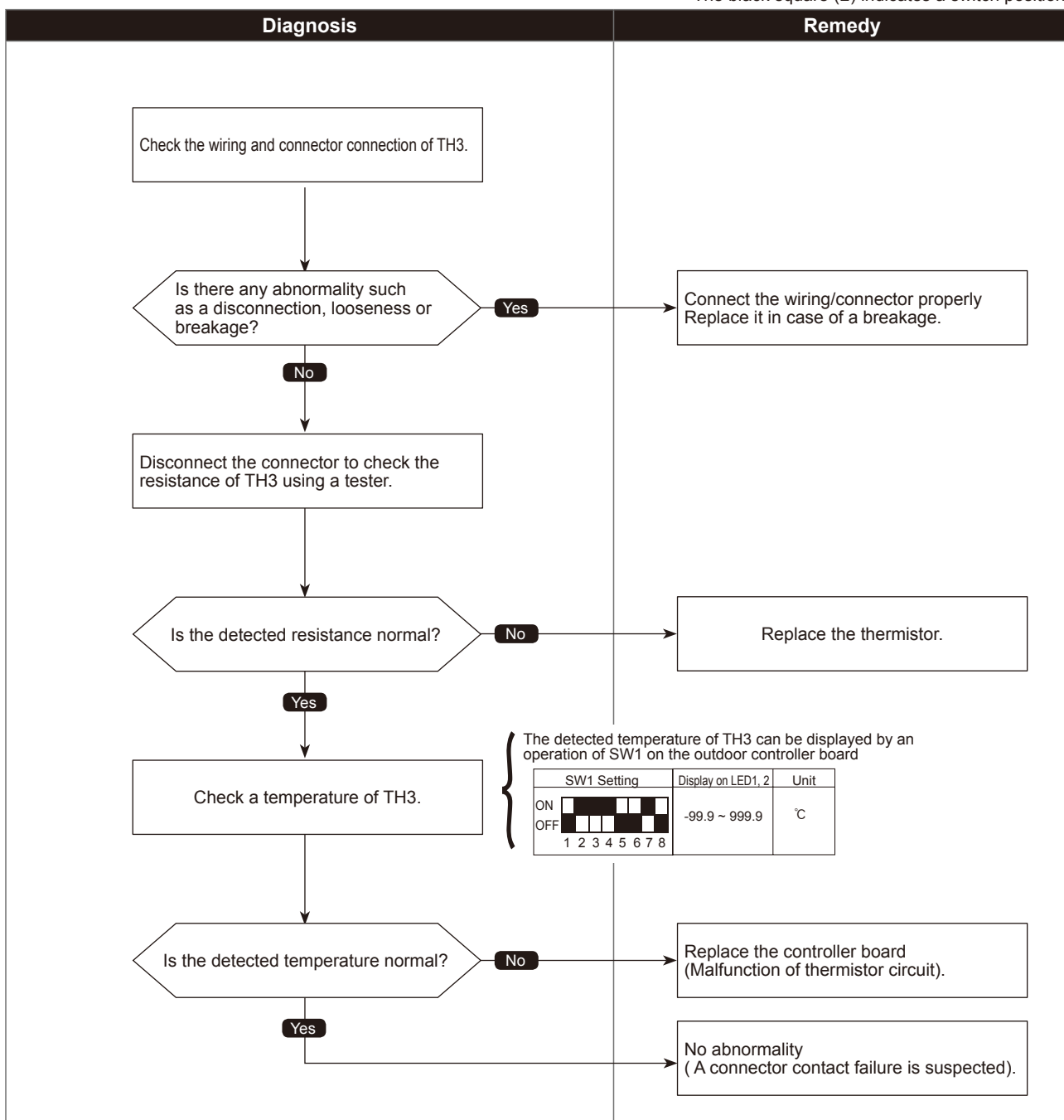

Ambient thermistor (TH7) open/short

Abnormal points and detection methods	Causes and check points
Abnormal if TH7 detects to be open/short Open: -40 °C or less Short: 90 °C or more TH7: Thermistor <Ambient>	① Disconnection or contact failure of connectors ② Characteristic defect of thermistor ③ Defective outdoor controller board

- Diagnosis of defectives
 Make sure to turn the power OFF before connecting/disconnecting any connectors, or replacing boards.

The black square (■) indicates a switch position.

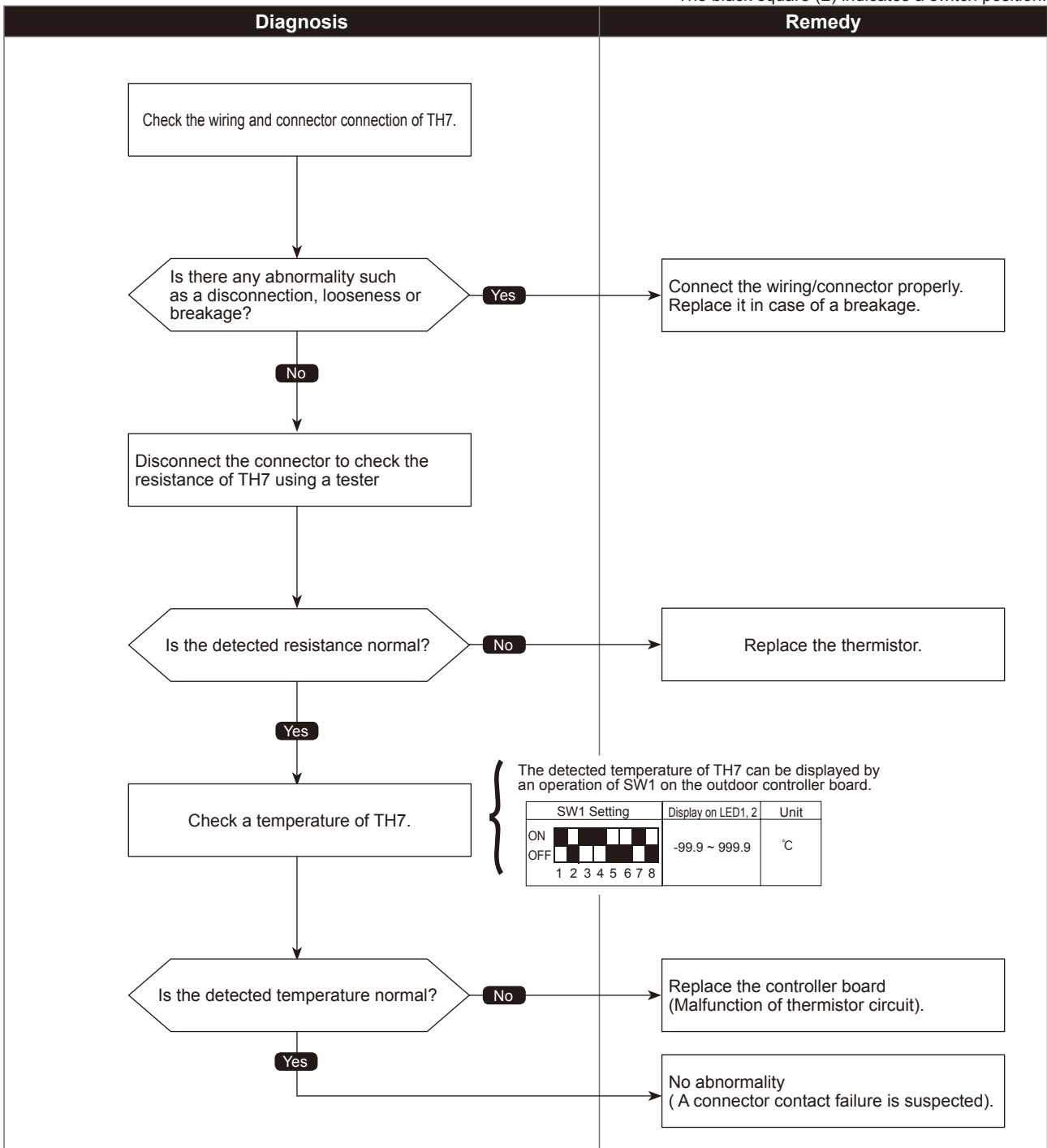

HIC pipe temperature thermistor (TH2) open/short

Abnormal points and detection methods	Causes and check points
Abnormal if TH2 detects to be open/short. Open: -40 °C or less Short: 90 °C or more TH2: Thermistor <HIC pipe>	① Disconnection or contact failure of connectors ② Characteristic defect of thermistor ③ Defective outdoor controller board

●Diagnosis of defectives

Make sure to turn the power OFF before connecting/disconnecting any connectors, or replacing boards.

The black square (■) indicates a switch position.

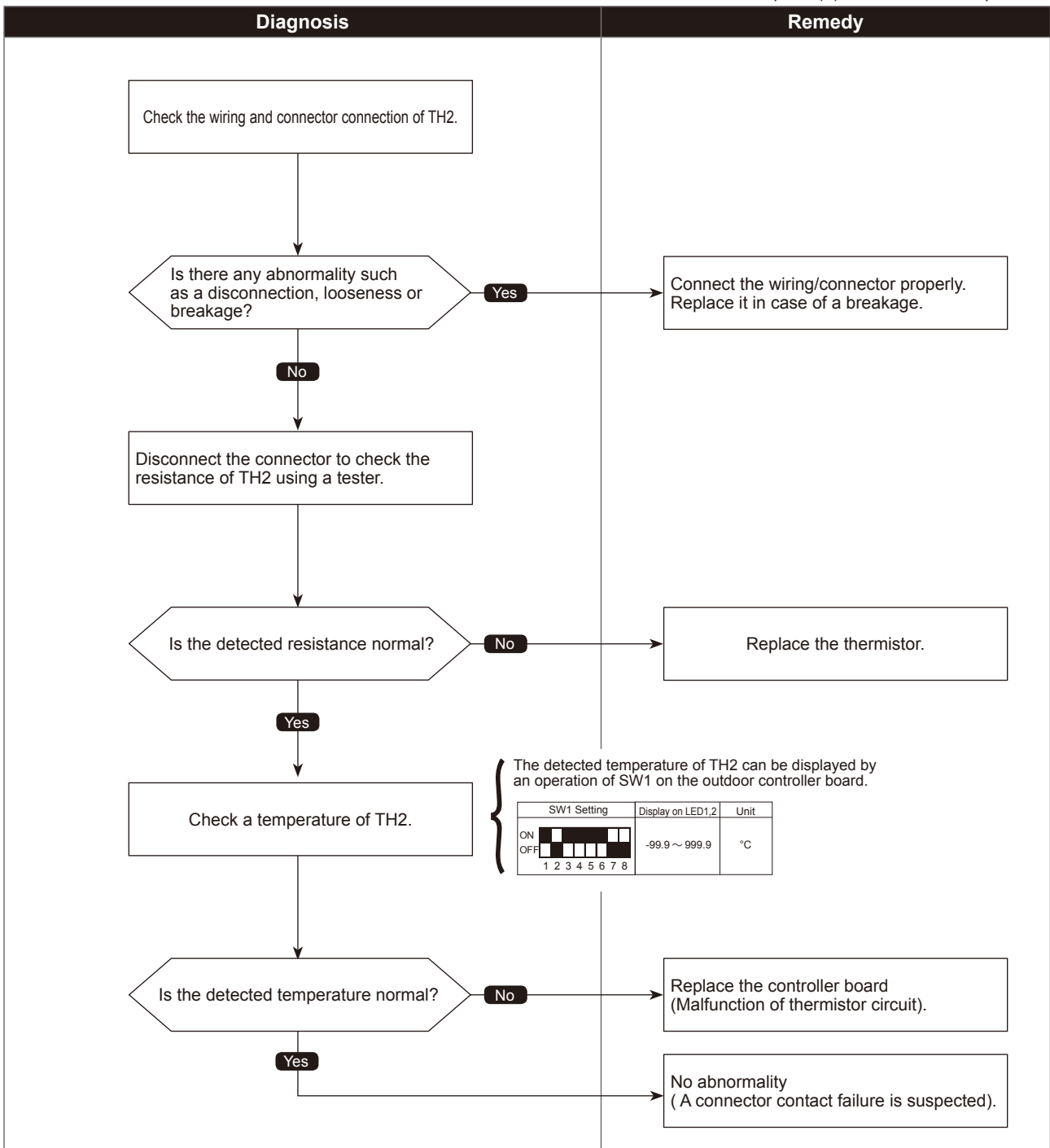

Heat Sink temperature thermistor(TH8) open/short

Abnormal points and detection methods	Causes and check points
Abnormal if TH8 detects to be open/short. ①P112/125/140V model <Internal thermistor> Open: - 35.1 °C or less Short: 170.3 °C or more ②P112/125/140Y model Open: - 34.8 °C or less Short: 102 °C or more TH8: Thermistor <Heat Sink>	① Disconnection or contact failure of connectors ② Characteristic defect of thermistor ③ Defective outdoor controller board

●Diagnosis of defectives

Make sure to turn the power OFF before connecting/disconnecting any connectors, or replacing boards.

The black square (■) indicates a switch position.

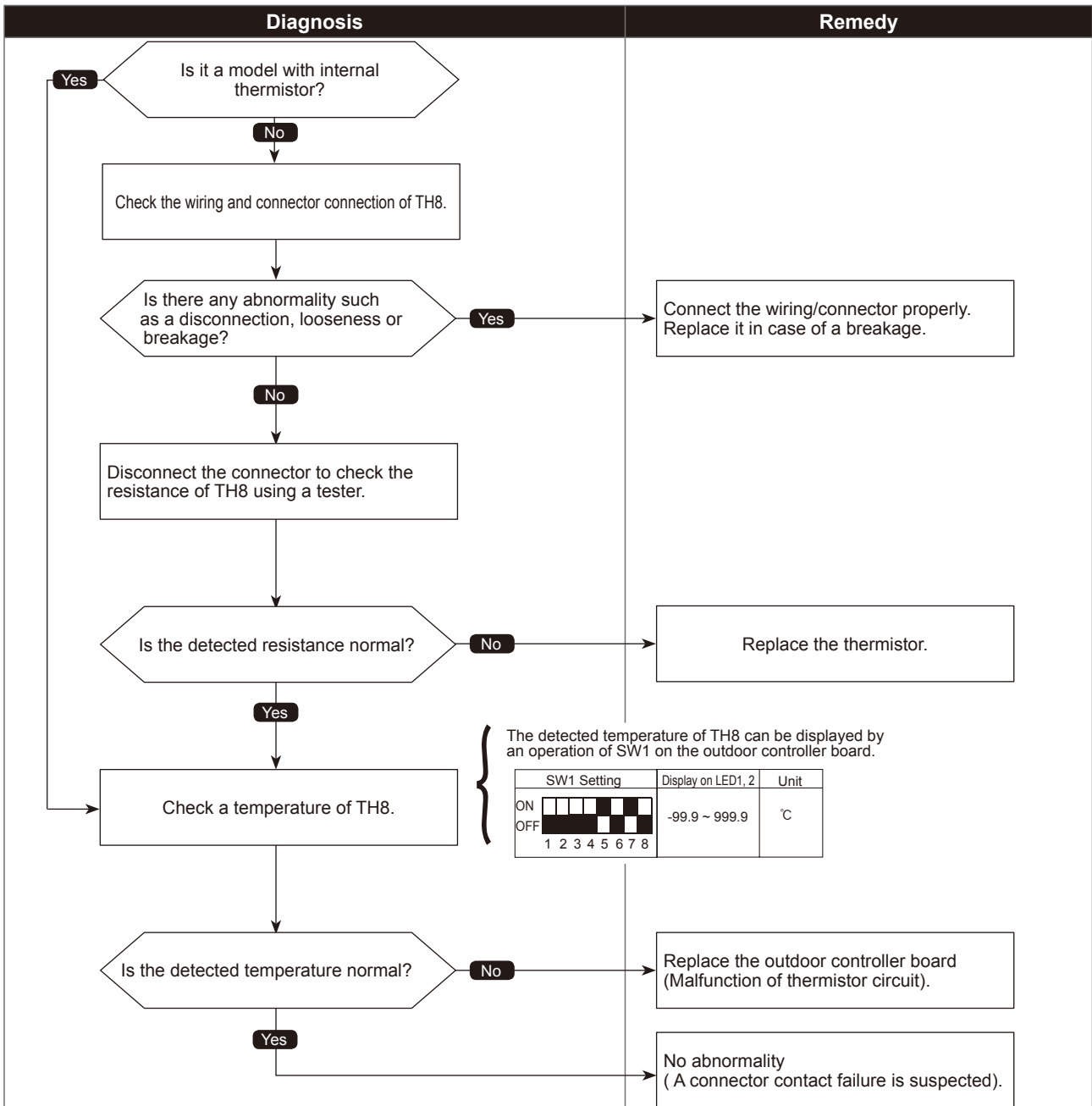

High-pressure sensor (63HS) trouble

Abnormal points and detection methods	Causes and check points
<p>① When the detected pressure in the high-pressure sensor is 1kgf/cm² or less during operation, the compressor stops operation and enters into an anti-restart mode for 3 minutes.</p> <p>② When the detected pressure is 1kgf/cm² immediately before restarting, the compressor falls into an abnormal stop with a check code <5201>.</p> <p>③ For 3 minutes after compressor restarting, during defrosting operation, and for 3 minutes after returning from defrosting operation, above mentioned symptoms are not determined as abnormal.</p>	<p>① Defective high-pressure sensor</p> <p>② Decrease of internal pressure caused by gas leakage</p> <p>③ Disconnection or contact failure of connector</p> <p>④ Malfunction of input circuit on outdoor controller board</p>

●Diagnosis of defectives

Make sure to turn the power OFF before connecting/disconnecting any connectors, or replacing boards.

The black square (■) indicates a switch position.

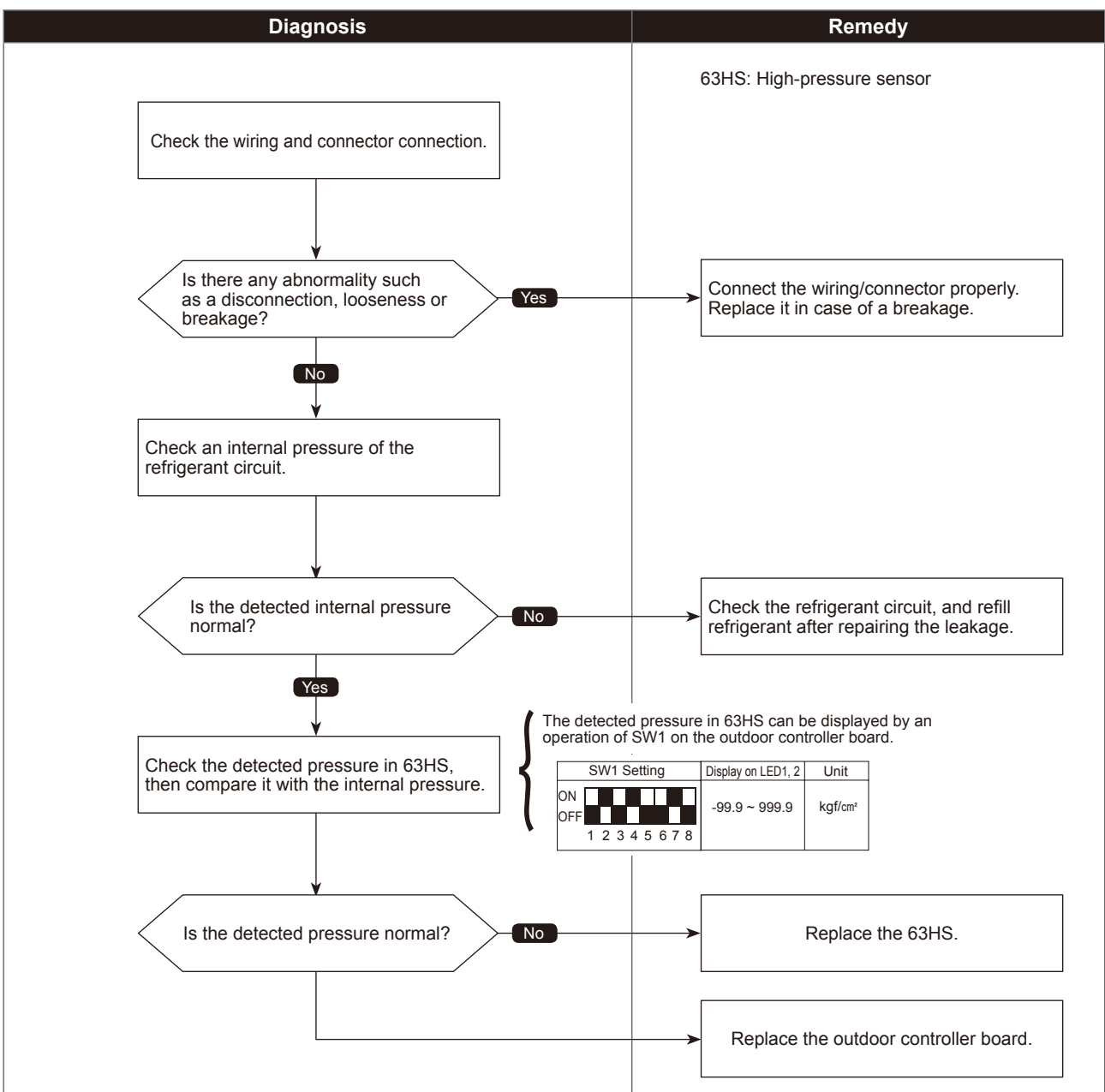

Low-pressure sensor (63LS) trouble

Abnormal points and detection methods	Causes and check points
① When the detected pressure in the low-pressure sensor is -2.3kgf/cm^2 or less, or 23.1kgf/cm^2 or more during operation, the compressor stops operation with a check code <5202>. ② For 3 minutes after compressor restarting, during defrosting operation, and for 3 minutes after returning from defrosting operation, above mentioned symptoms are not determined as abnormal.	① Defective low-pressure sensor ② Decrease of internal pressure caused by gas leakage ③ Disconnection or contact failure of connector ④ Malfunction of input circuit on outdoor controller board

●Diagnosis of defectives

Make sure to turn the power OFF before connecting/disconnecting any connectors, or replacing boards.

The black square (■) indicates a switch position.

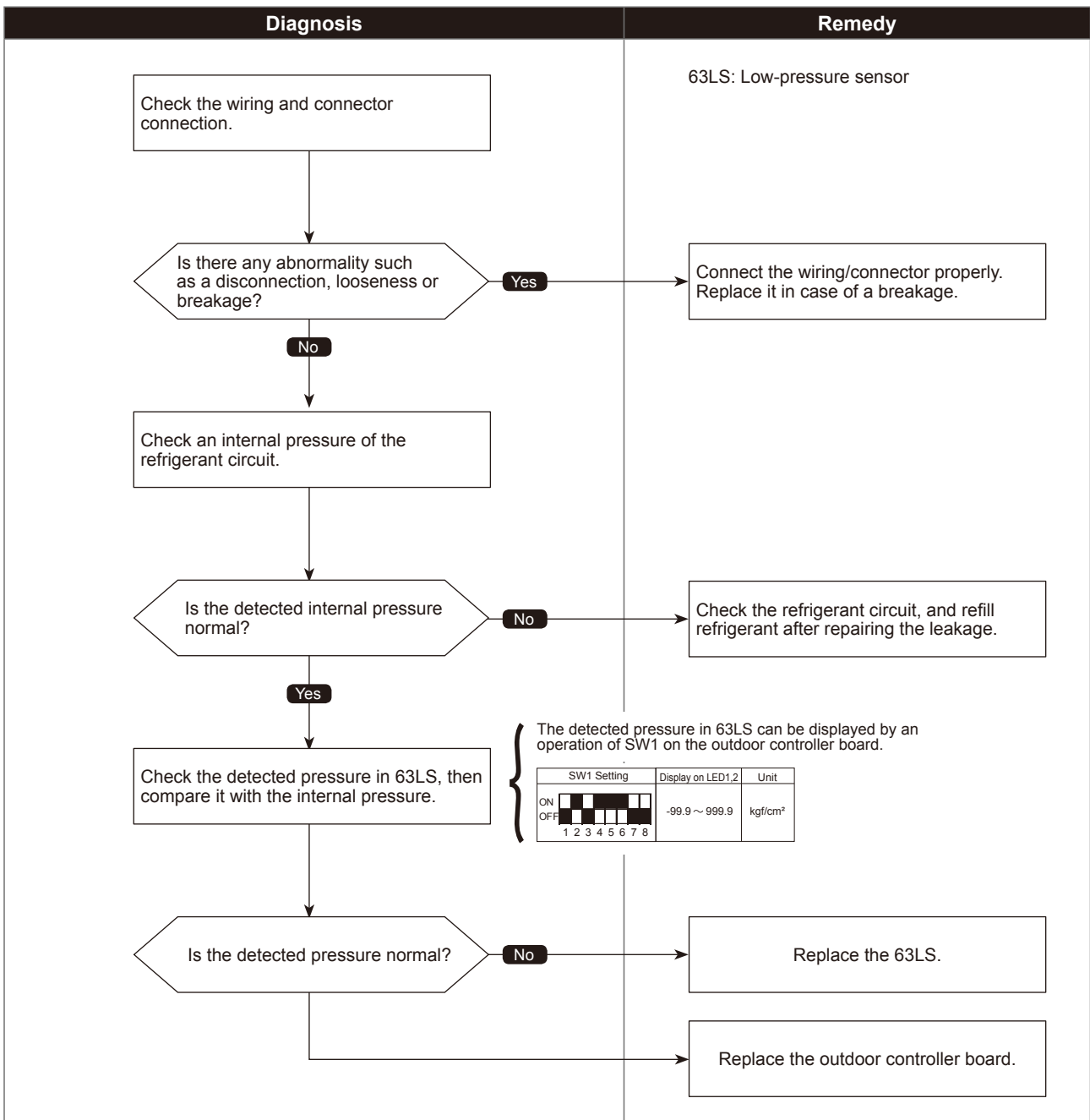

Primary current error

Abnormal points and detection methods	Causes and check points
Abnormal if the detected current sensor input value (primary current) during compressor operation is outside the specified range.	① Decrease/ trouble of power supply voltage ② Disconnection of compressor wiring ③ Input sensor trouble on outdoor power board

- Diagnosis of defectives
 Make sure to turn the power OFF before connecting/disconnecting any connectors, or replacing boards.

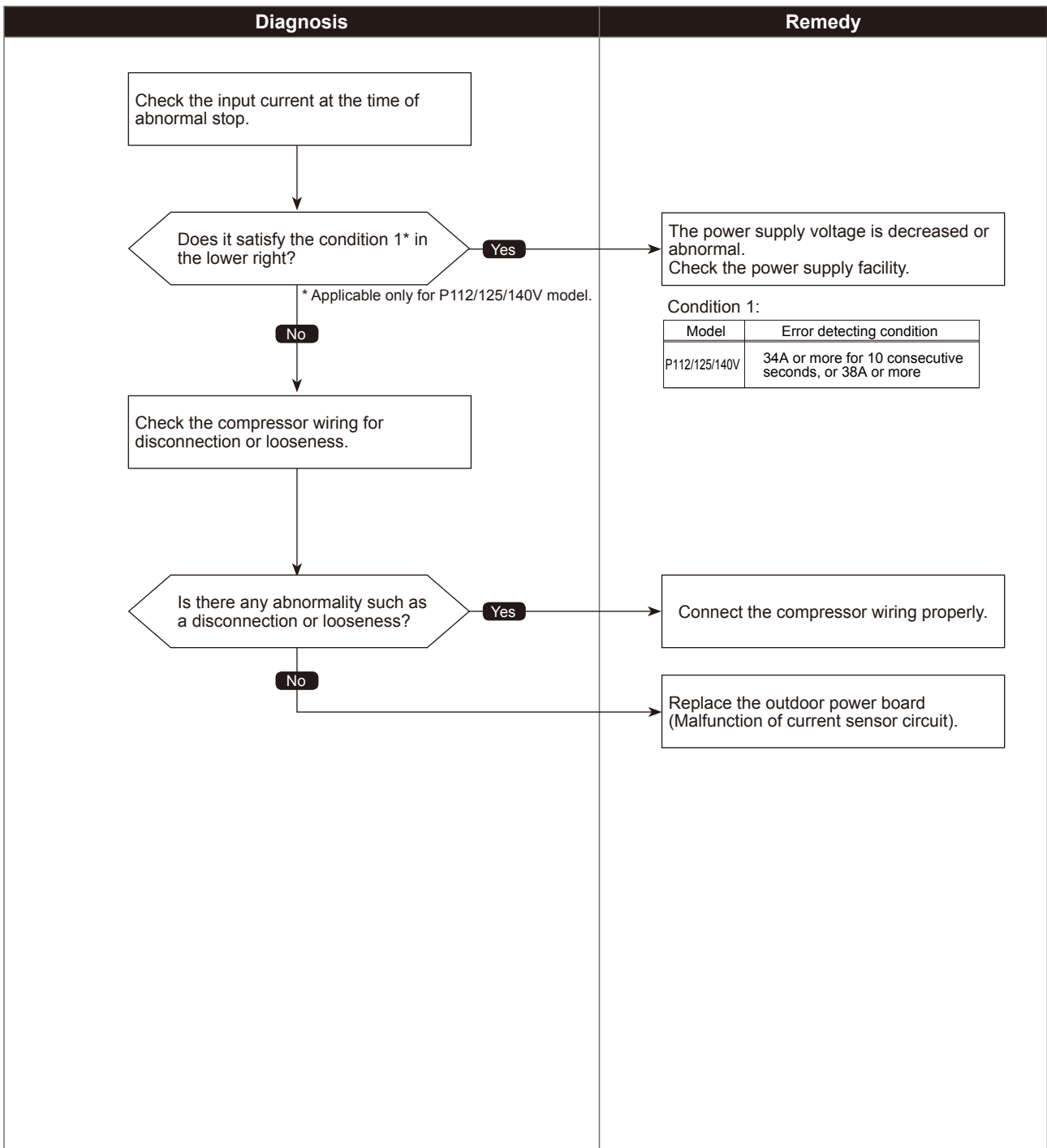

Check code

5701

Models equipped with the float switch Contact failure of drain float switch

Abnormal points and detection methods

<Models equipped with the float switch>
Abnormal if the connector on the drain float switch side CN4F is detected to be disconnected.

Causes and check points

- ① Contact failure of connector CN4F
- ② Defective indoor controller board

•Diagnosis of defectives

Make sure to turn the power OFF before connecting/disconnecting any connectors, or replacing boards

Diagnosis	Remedy
<p><Models equipped with the float switch></p> <p>Disconnect and reconnect the connector for float switch on the indoor controller board side, then turn the power back ON.</p> <p>Is the check code <5701> still displayed?</p> <p>Yes</p> <p>Check if it is short-circuited between pins 3-4 of the connector (CN4F) on the float switch side.</p> <p>Is it short-circuited?</p>	<p>No abnormality. A connector or wiring contact failure is suspected.</p> <p>Replace the connector for float switch.</p> <p>Replace the indoor controller board.</p>

Check code

6600

Duplex address error

Abnormal points and detection methods	Causes and check points
Abnormal if 2 or more units with the same address are existing.	① There are 2 units or more with the same address in their controller among outdoor unit, indoor unit, Fresh Master, Lossnay or remote controller ② Noise interference on indoor/outdoor connectors

●Diagnosis of defectives

Make sure to turn the power OFF before connecting/disconnecting any connectors, or replacing boards.

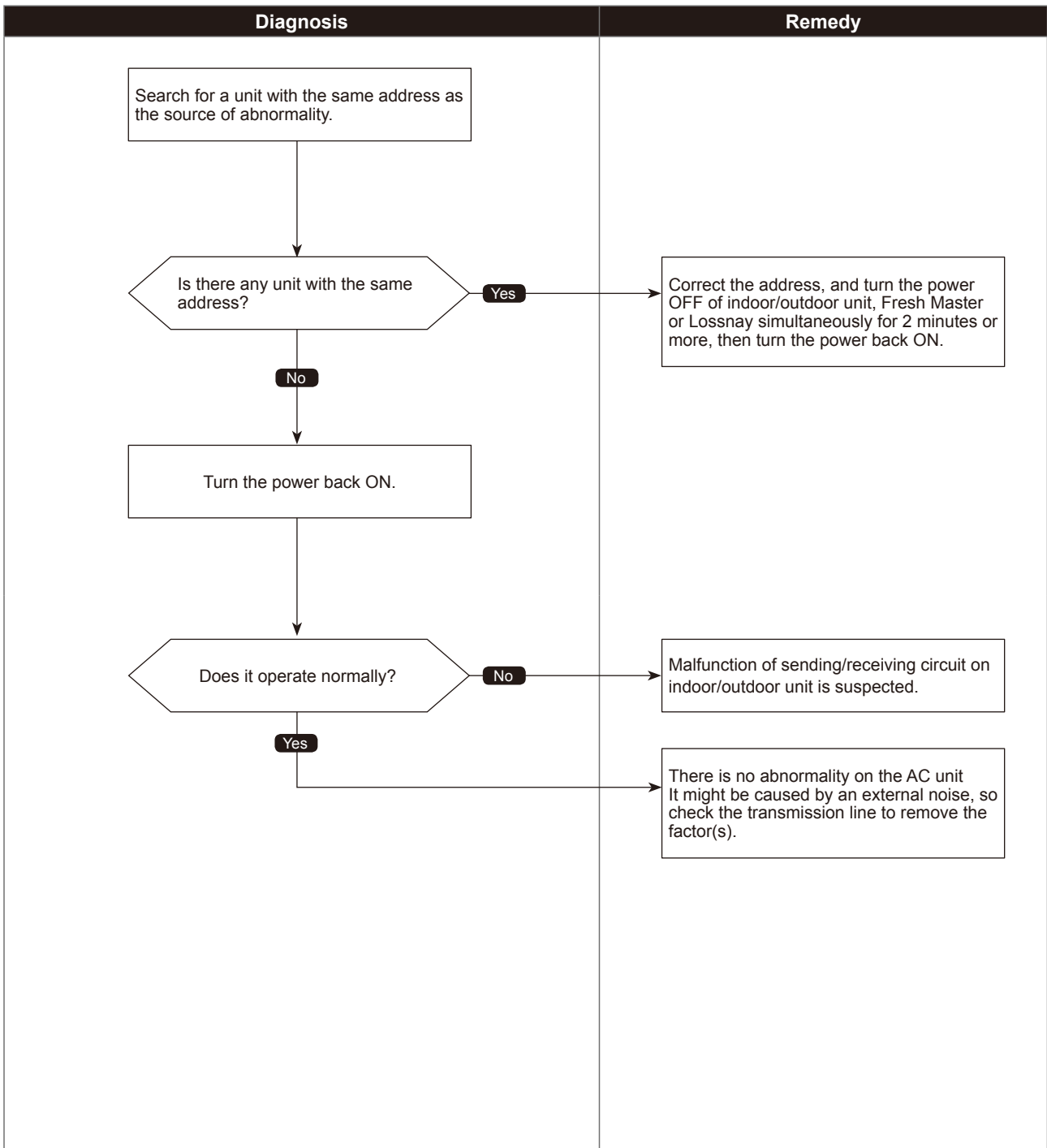

Check code

6602

Transmission processor H/W error

Abnormal points and detection methods	Causes and check points
Abnormal if the transmission line shows "1" although the transmission processor transmitted "0".	<ul style="list-style-type: none">① A transmitting data collision occurred because of a wiring work or polarity change has performed while the power is ON on either of the indoor/outdoor unit, Fresh Master or Lossnay② Malfunction of transmitting circuit on transmission processor③ Noise interference on indoor/outdoor connectors

●Diagnosis of defectives

Make sure to turn the power OFF before connecting/disconnecting any connectors, or replacing boards.

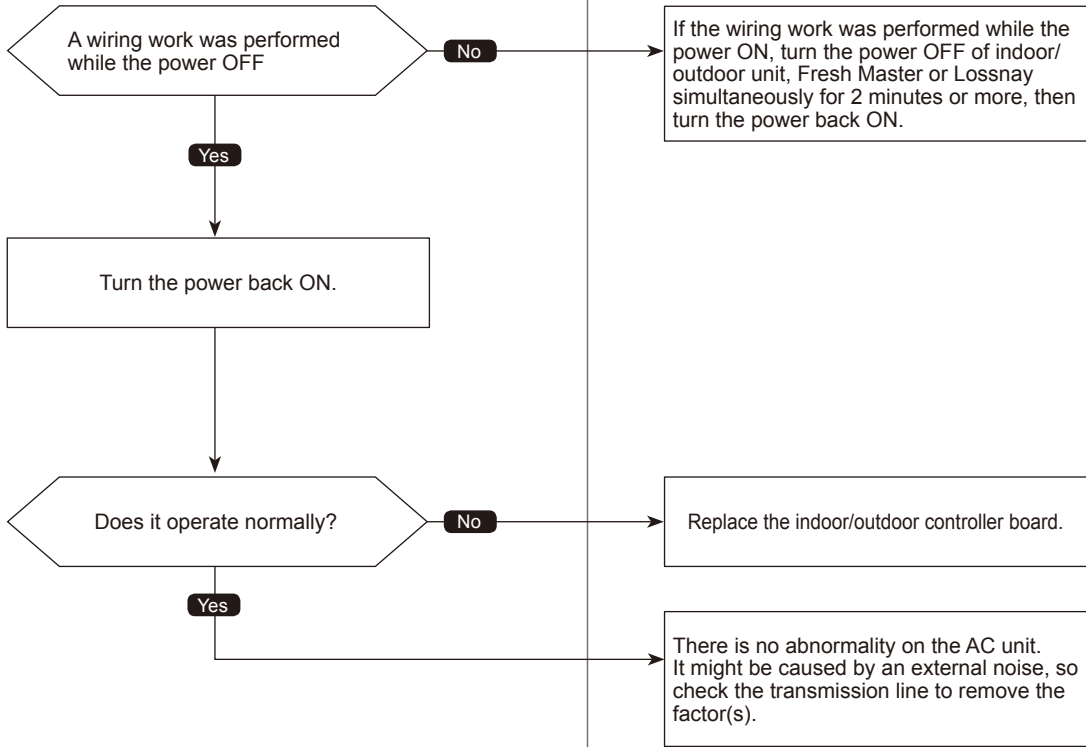
Diagnosis	Remedy
	

Transmission bus BUSY error

Abnormal points and detection methods	Causes and check points
<p>① Over error by collision Abnormal if no-transmission status caused by a transmitting data collision is consecutive for 8 to 10 minutes.</p> <p>② Abnormal if a status, that data is not allowed on the transmission line because of noise and such, is consecutive for 8 to 10 minutes</p>	<p>① The transmission processor is unable to transmit due to a short-cycle voltage such as noise is mixed on the transmission line.</p> <p>② The transmission processor is unable to transmit due to an increase of transmission data amount caused by a miswiring of the terminal block (transmission line) (TB3) and the terminal block (centralized control line) (TB7) on the outdoor unit.</p> <p>③ The share on transmission line becomes high due to a mixed transmission caused by a malfunction of repeater on the outdoor unit, which is a function to connect/disconnect transmission from/to control system and centralized control system.</p>

●Diagnosis of defectives

Make sure to turn the power OFF before connecting/disconnecting any connectors, or replacing boards.

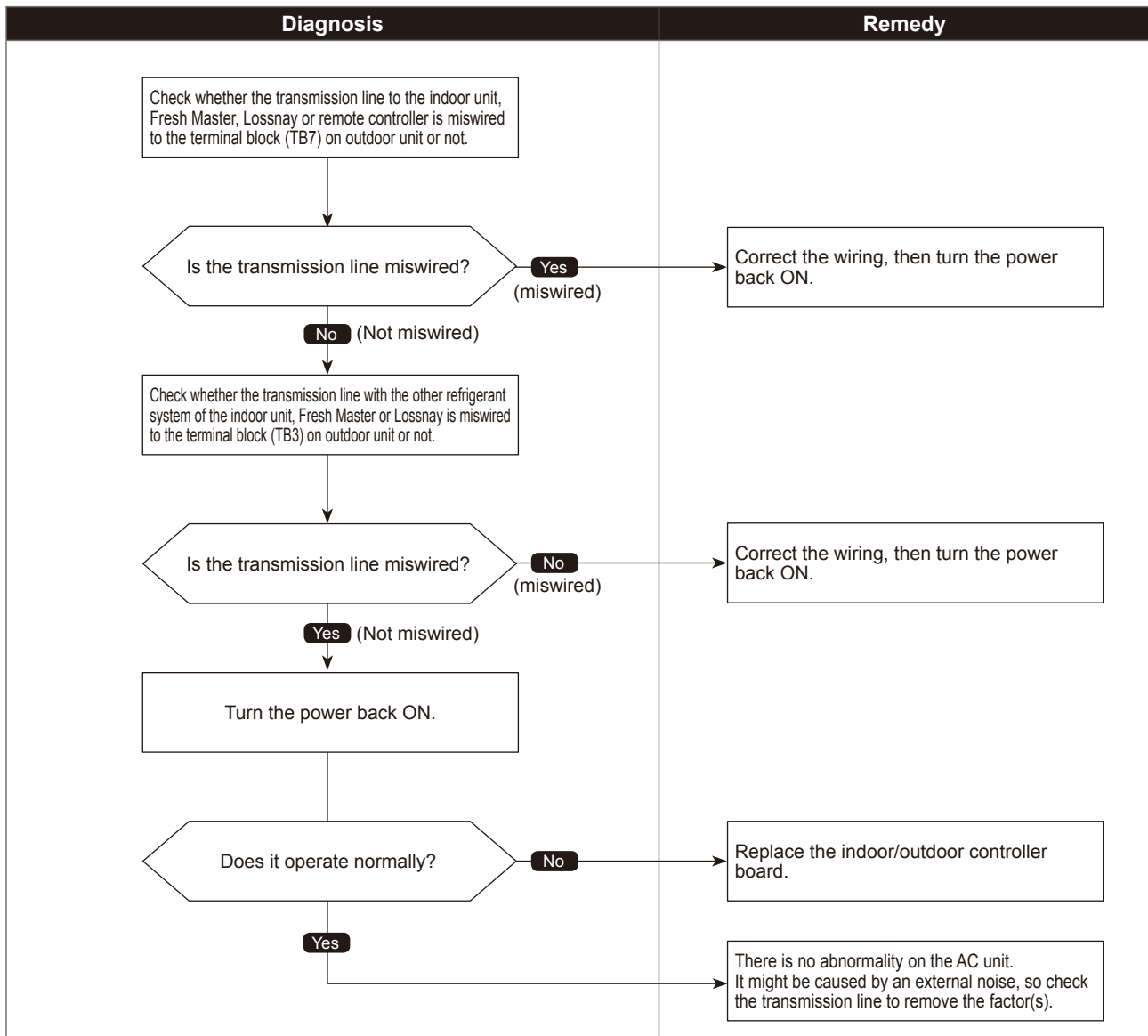

Signal communication error with transmission processor

Abnormal points and detection methods	Causes and check points
① Abnormal if the data of unit/transmission processor were not normally transmitted. ② Abnormal if the address transmission from the unit processor was not normally transmitted.	① Accidental disturbance such as noise or lightning surge ② Hardware malfunction of transmission processor

● Diagnosis of defectives

Make sure to turn the power OFF before connecting/disconnecting any connectors, or replacing boards.

Diagnosis	Remedy
<p>Turn the power OFF of indoor/outdoor unit, Fresh Master, Lossnay and remote controller simultaneously for 2 minutes or more, then turn the power back ON.</p> <p>Does it operate normally?</p> <p>Yes</p> <p>No</p>	<p>Replace the controller (Defect of error source controller).</p> <p>There is no abnormality on the AC unit. It might be caused by an external noise, so check the transmission line to remove the factor(s).</p>

No ACK error

Abnormal points and detection methods	Causes and check points
<p>① Represents a common error detection An abnormality detected by the sending side controller when receiving no ACK from the receiving side, though signal was once sent. The sending side searches the error in 30 seconds interval for 6 times continuously.</p>	<p>① The previous address unit does not exist since the address switch was changed while in electric continuity status. ② Decline of transmission voltage/signal caused by tolerance over on transmission line ·At the furthest end: 200m ·On remote controller line: (12m) ③ Decline of transmission voltage/ signal due to unmatched transmission line types ·Types for shield line: CVVS, CPEVS ·Line diameter: 1.25 mm² or more ④ Decline of transmission voltage/ signal due to excessive number of connected units ⑤ Malfunction due to accidental disturbance such as noise or lightning surge ⑥ Defect of error source controller</p>
<p>② The cause of displayed address and attribute is on the outdoor unit side An abnormality detected by the indoor unit if receiving no ACK when transmitting signal from the indoor unit to the outdoor unit.</p>	<p>① Contact failure of indoor/outdoor unit transmission line. ② Disconnection of transmission connector (CN2M) on indoor unit. ③ Malfunction of sending/receiving circuit on indoor/outdoor unit.</p>
<p>③ The cause of displayed address and attribute is on the indoor unit side An abnormality detected by the remote controller if receiving no ACK when sending data from the remote controller to the indoor unit.</p>	<p>① While operating with multi refrigerant system indoor units, an abnormality is detected when the indoor unit transmit signal to the remote controller during the other refrigerant-system outdoor unit is turned OFF, or within 2 minutes after it turned back ON. ② Contact failure of indoor unit or remote controller transmission line ③ Disconnection of transmission connector (CN2M) on indoor unit ④ Malfunction of sending/receiving circuit on indoor unit or remote controller</p>
<p>④ The cause of the displayed address and attribute is on the remote controller side An abnormality detected by the indoor unit if receiving no ACK when transmitting signal from the indoor unit to the remote controller.</p>	<p>① While operating with multi refrigerant system indoor units, an abnormality is detected when the indoor unit transmit signal to the remote controller during the other refrigerant-system outdoor unit is turned OFF, or within 2 minutes after it turned back ON. ② Contact failure of indoor unit or remote controller transmission line ③ Disconnection of transmission connector (CN2M) on indoor unit ④ Malfunction of sending/receiving circuit on indoor unit or remote controller</p>

Abnormal points and detection methods	Causes and check points
<p>⑤ The cause of displayed address and attribute is on the Fresh Master side An abnormality detected by the indoor unit if receiving no ACK when transmitting signal from the indoor unit to the Fresh Master.</p>	<p>① While the indoor unit is operating with multi refrigerant system Fresh Master, an abnormality is detected when the indoor unit transmits signal to the remote controller while the outdoor unit with the same refrigerant system as the Fresh Master is turned OFF, or within 2 minutes after it turned back ON.</p> <p>② Contact failure of indoor unit or Fresh Master transmission line</p> <p>③ Disconnection of transmission connector (CN2M) on indoor unit or Fresh Master</p> <p>④ Malfunction of sending/receiving circuit on indoor unit or Fresh Master</p>
<p>⑥ The cause of displayed address and attribute is on Lossnay side An abnormality detected by the indoor unit if receiving no ACK when the indoor unit transmit signal to the Lossnay.</p>	<p>① An abnormality is detected when the indoor unit transmits signal to Lossnay while the Lossnay is turned OFF.</p> <p>② While the indoor unit is operating with the other refrigerant Lossnay, an abnormality is detected when the indoor unit transmits signal to the Lossnay while the outdoor unit with the same refrigerant system as the Lossnay is turned OFF, or within 2 minutes after it turned back ON.</p> <p>③ Contact failure of indoor unit or Lossnay transmission line</p> <p>④ Disconnection of transmission connector (CN2M) on indoor unit</p> <p>⑤ Malfunction of sending/receiving circuit on indoor unit or Lossnay</p>
<p>⑦ The controller of displayed address and attribute is not recognized</p>	<p>① The previous address unit does not exist since the address switch was changed while in electric continuity status.</p> <p>② An abnormality detected at transmitting from the indoor unit since the Fresh Master/Lossnay address are changed after synchronized setting of Fresh Master/Lossnay by the remote controller.</p>

●Diagnosis of defectives

Make sure to turn the power OFF before connecting/disconnecting any connectors, or replacing boards.

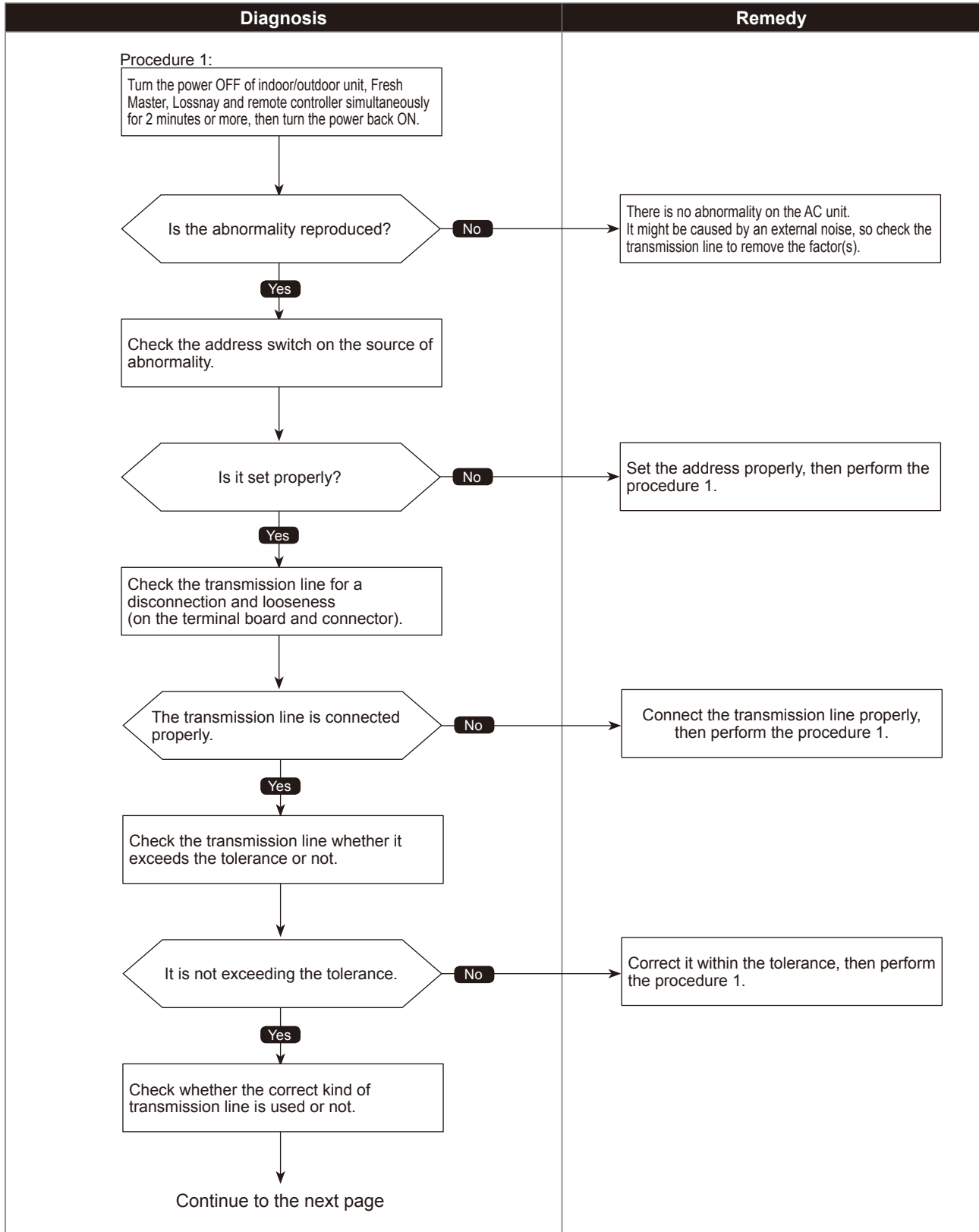

●Diagnosis of defectives

Make sure to turn the power OFF before connecting/disconnecting any connectors, or replacing boards.

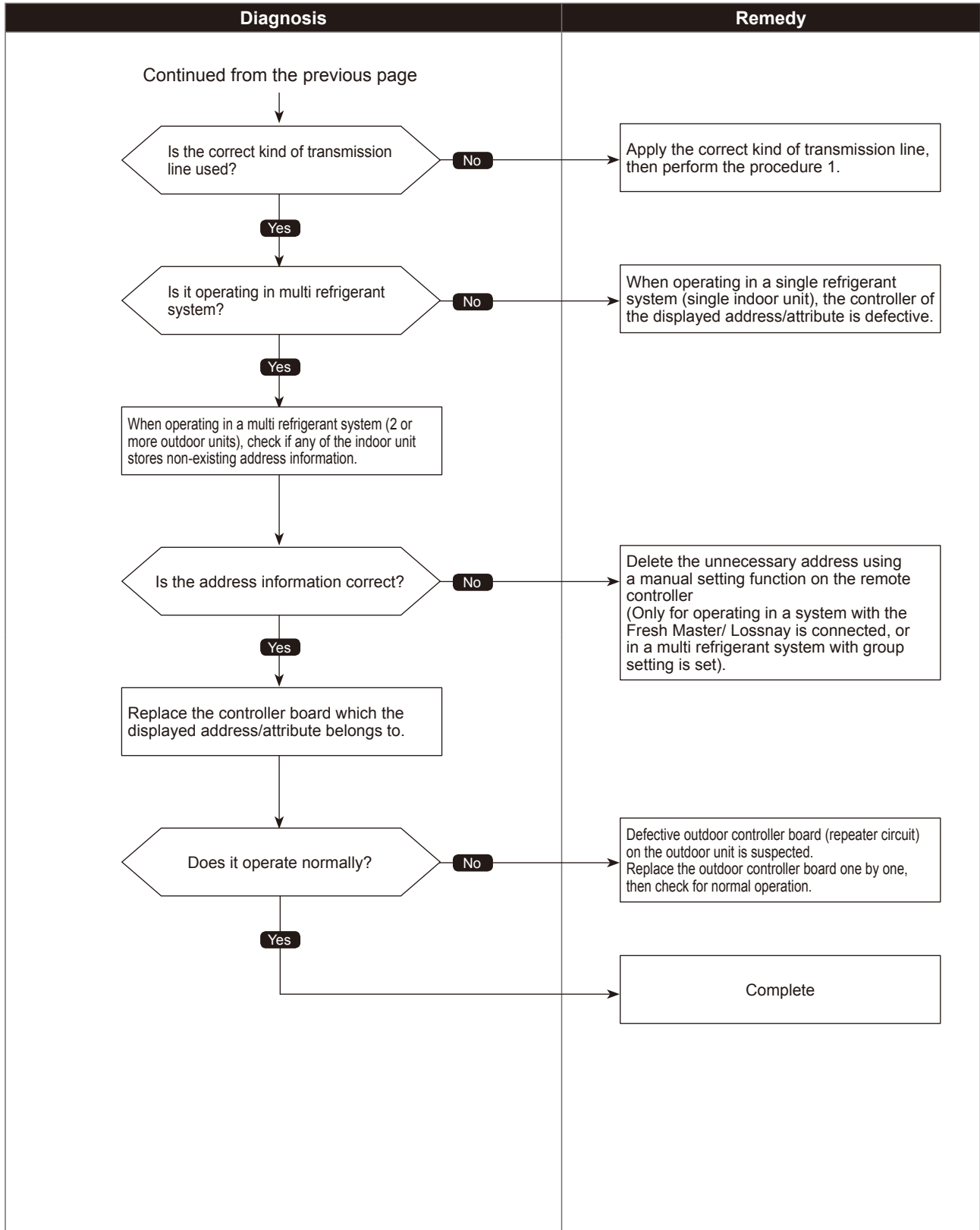

No response frame error

Abnormal points and detection methods	Causes and check points
Abnormal if receiving no response command while already received ACK. The sending side searches the error in 30 seconds interval for 6 times continuously.	① Continuous failure of transmission due to noise etc ② Decline of transmission voltage/signal caused by tolerance over on transmission line ·At the furthest end: 200m ·On remote controller line: (12m) ③ Decline of transmission voltage/ signal due to unmatched transmission line types ·Types for shield line: CVVS, CPEVS ·Line diameter: 1.25 mm ² or more ④ Accidental malfunction of error source controller

●Diagnosis of defectives

Make sure to turn the power OFF before connecting/disconnecting any connectors, or replacing boards.

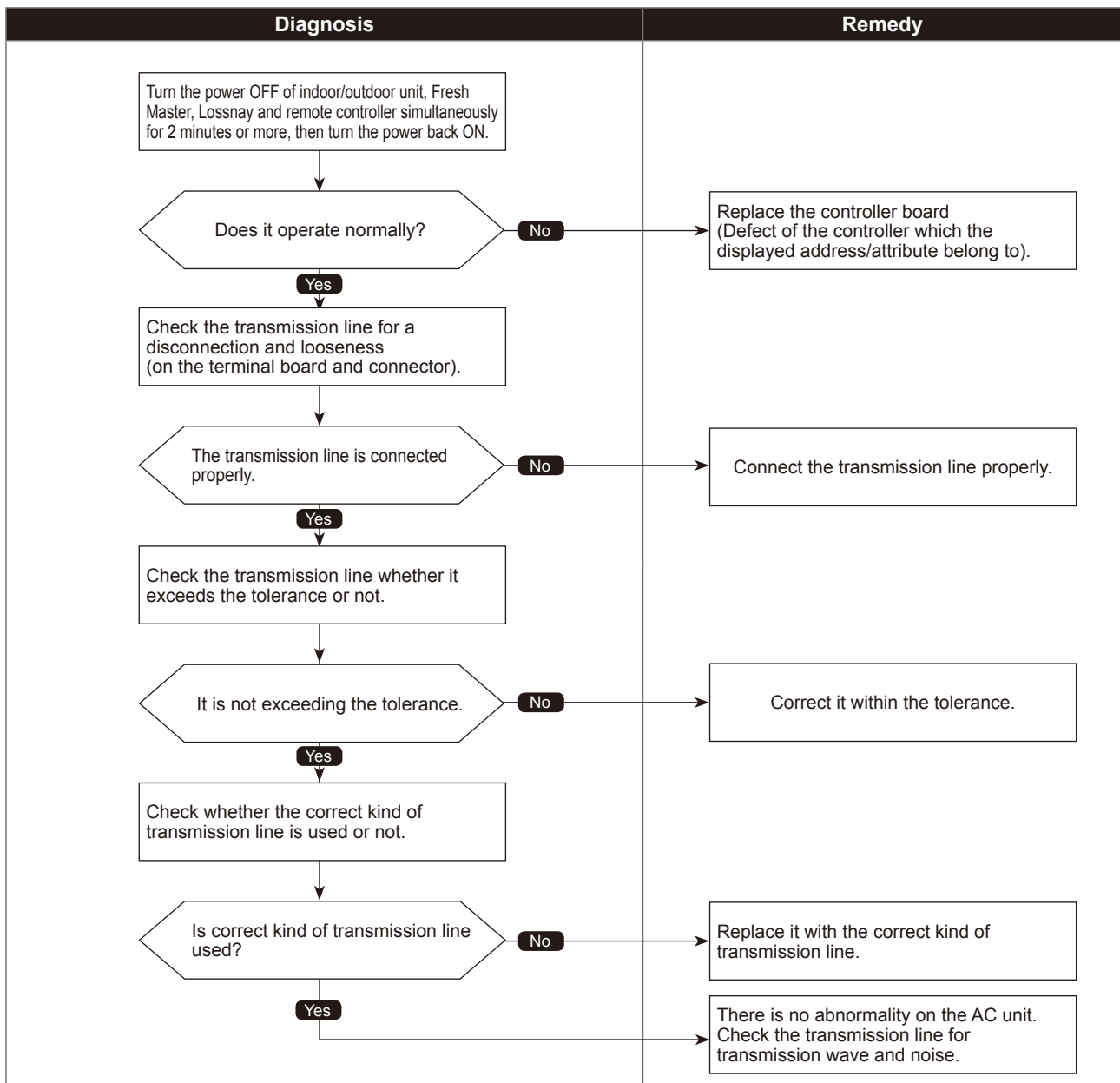

MA communication receive error

Abnormal points and detection methods	Causes and check points
<p>Detected in remote controller or indoor unit:</p> <ul style="list-style-type: none"> ① When the main or sub remote controller cannot receive signal from indoor unit which has the "0" address. ② When the sub remote controller cannot receive signal. ③ When the indoor controller board cannot receive signal from remote controller or another indoor unit. ④ When the indoor controller board cannot receive signal. 	<ul style="list-style-type: none"> ① Contact failure of remote controller wirings ② Irregular Wiring (A wiring length, number of connecting remote controllers or indoor units, or a wiring thickness does not meet the conditions specified in the chapter "Electrical Work" in the indoor unit Installation Manual.) ③ Malfunction of the remote controller sending/receiving circuit on indoor unit with the LED2 is blinking. ④ Malfunction of the remote controller sending/receiving circuit ⑤ Remote controller transmitting error caused by noise interference

●Diagnosis of defectives

Make sure to turn the power OFF before connecting/disconnecting any connectors, or replacing boards

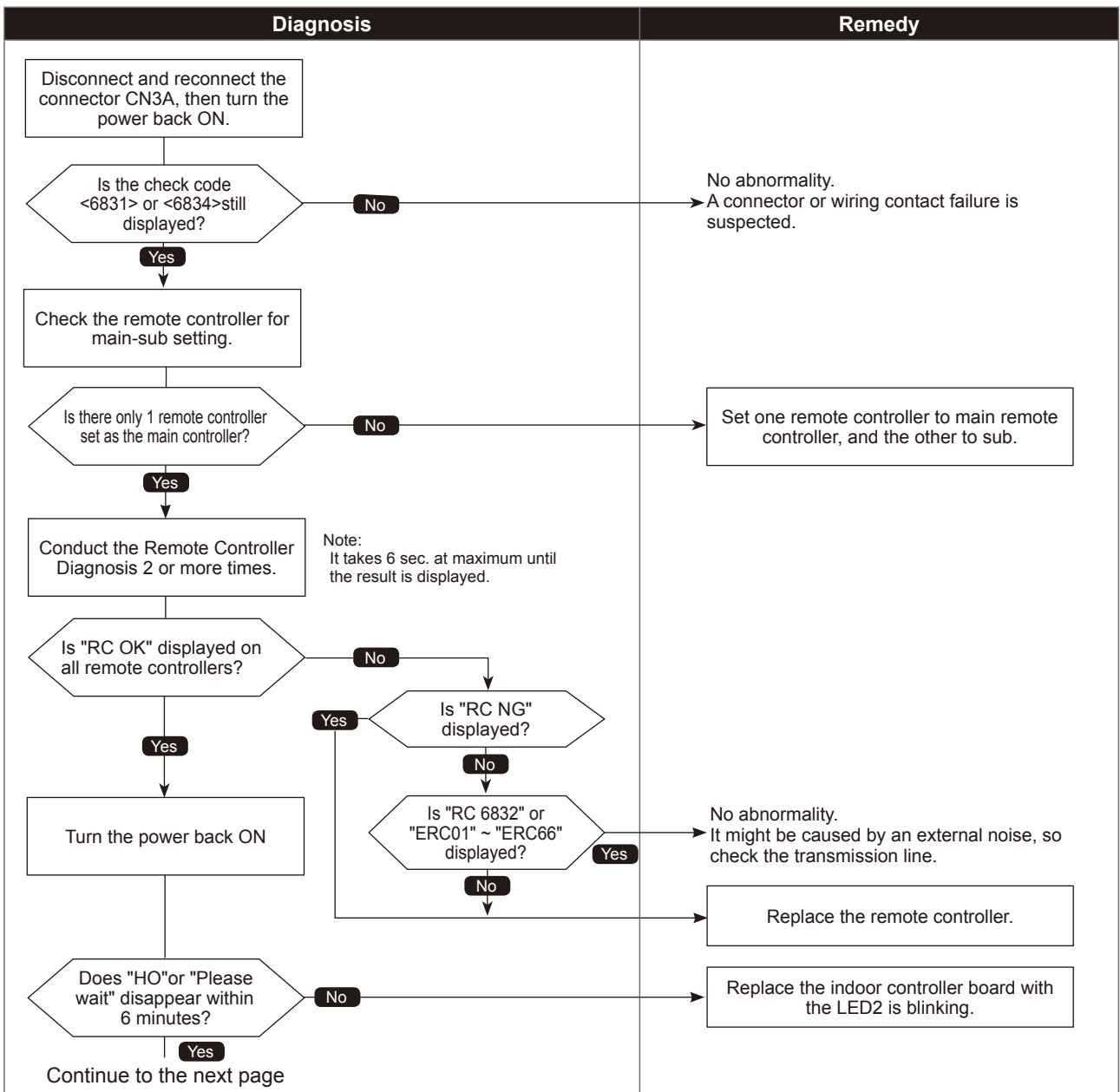

MA communication receive error

●Diagnosis of defectives

Make sure to turn the power OFF before connecting/disconnecting any connectors, or replacing boards

Diagnosis	Remedy
<p>Continued from the previous page</p> <pre> graph TD Start[Continued from the previous page] --> Step1[Refer to the chapter "Electrical Work".] Step1 --> Decision{Is the wiring connected properly, meeting the condition?} Decision -- No --> Remedy1[Connect the wiring properly as specified in the chapter "Electrical Work" in the indoor unit Installation Manual.] Decision -- Yes --> Remedy2[No abnormality. It might be caused by an external noise, so check the transmission line to remove the factor(s).] </pre>	<div data-bbox="970 797 1393 887" style="border: 1px solid black; padding: 5px;"> <p>Connect the wiring properly as specified in the chapter "Electrical Work" in the indoor unit Installation Manual.</p> </div> <p>No abnormality. It might be caused by an external noise, so check the transmission line to remove the factor(s).</p>

MA communication send error

Abnormal points and detection methods	Causes and check points
Detected in remote controller or indoor unit.	① There are 2 remote controllers set as main. ② Malfunction of remote controller sending/receiving circuit ③ Malfunction of sending/receiving circuit on indoor controller board ④ Remote controller transmitting error caused by noise interference

●Diagnosis of defectives

Make sure to turn the power OFF before connecting/disconnecting any connectors, or replacing boards

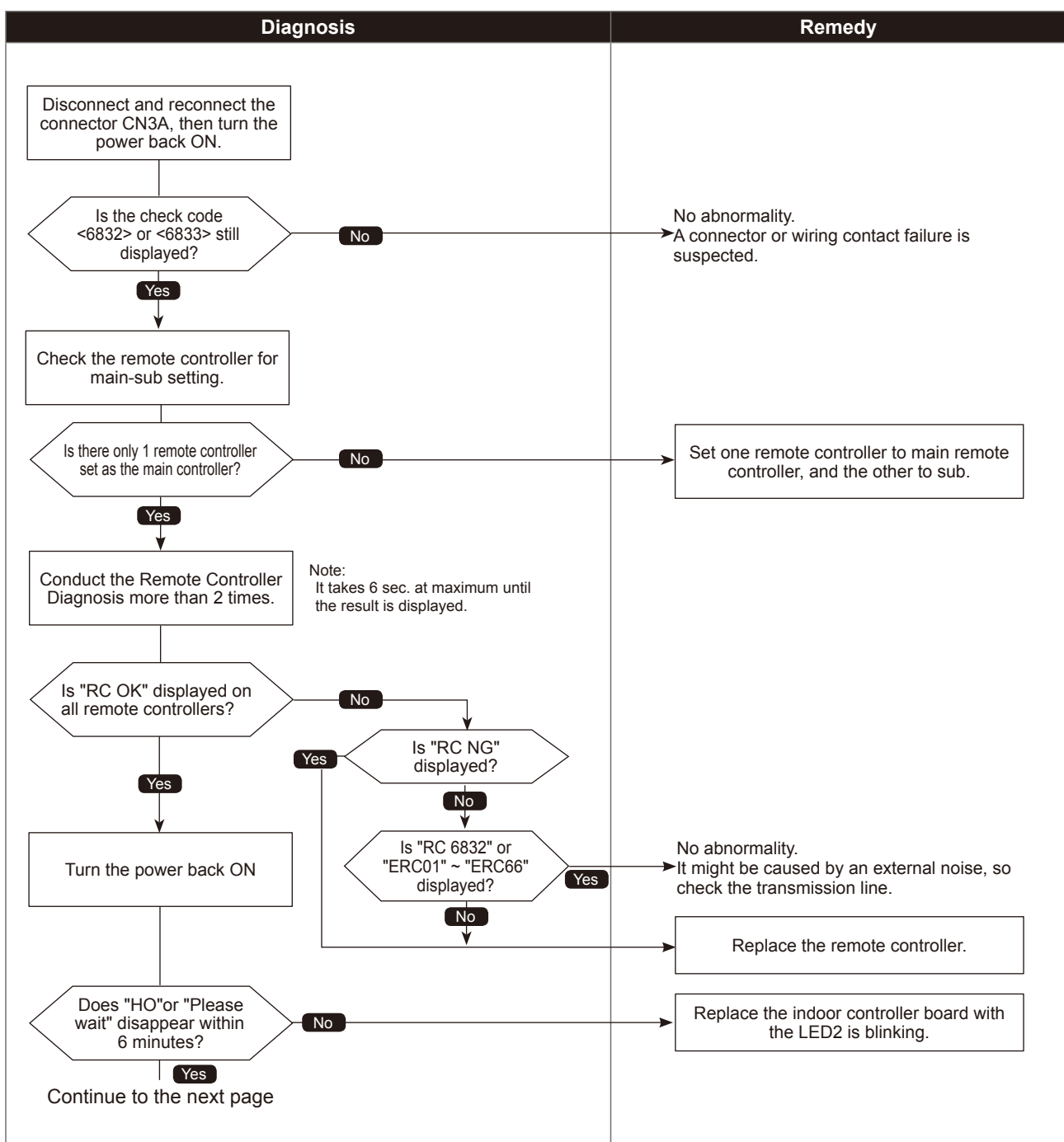

MA communication send error

●Diagnosis of defectives

Make sure to turn the power OFF before connecting/disconnecting any connectors, or replacing boards

Diagnosis	Remedy
<p>Continued from the previous page</p> <pre> graph TD Start[Continued from the previous page] --> Step1[Refer to the chapter "Electrical Work".] Step1 --> Decision{Is the wiring connected properly, meeting the condition?} Decision -- No --> Remedy1[Connect the wiring properly as specified in the chapter "Electrical Work" in the indoor unit Installation Manual.] Decision -- Yes --> Remedy2[No abnormality. It might be caused by an external noise, so check the transmission line to remove the factor(s).] </pre>	<p>Connect the wiring properly as specified in the chapter "Electrical Work" in the indoor unit Installation Manual.</p> <p>No abnormality. It might be caused by an external noise, so check the transmission line to remove the factor(s).</p>

Check code

7100

Total capacity error

Abnormal points and detection methods	Causes and check points
<p>When the total of the number on connected indoor unit model names exceeds the specified capacity level (130% of the number on the outdoor unit model name), a check code <7100> is displayed.</p>	<p>① The total of number on connected indoor unit model names exceeds the specified capacity level ·P112 model:~code 35 ·P125 model:~code 41 ·P140 model:~code 47</p> <p>② The model name code of the outdoor unit is registered wrongly.</p>

●Diagnosis of defectives

Make sure to turn the power OFF before connecting/disconnecting any connectors, or replacing boards.

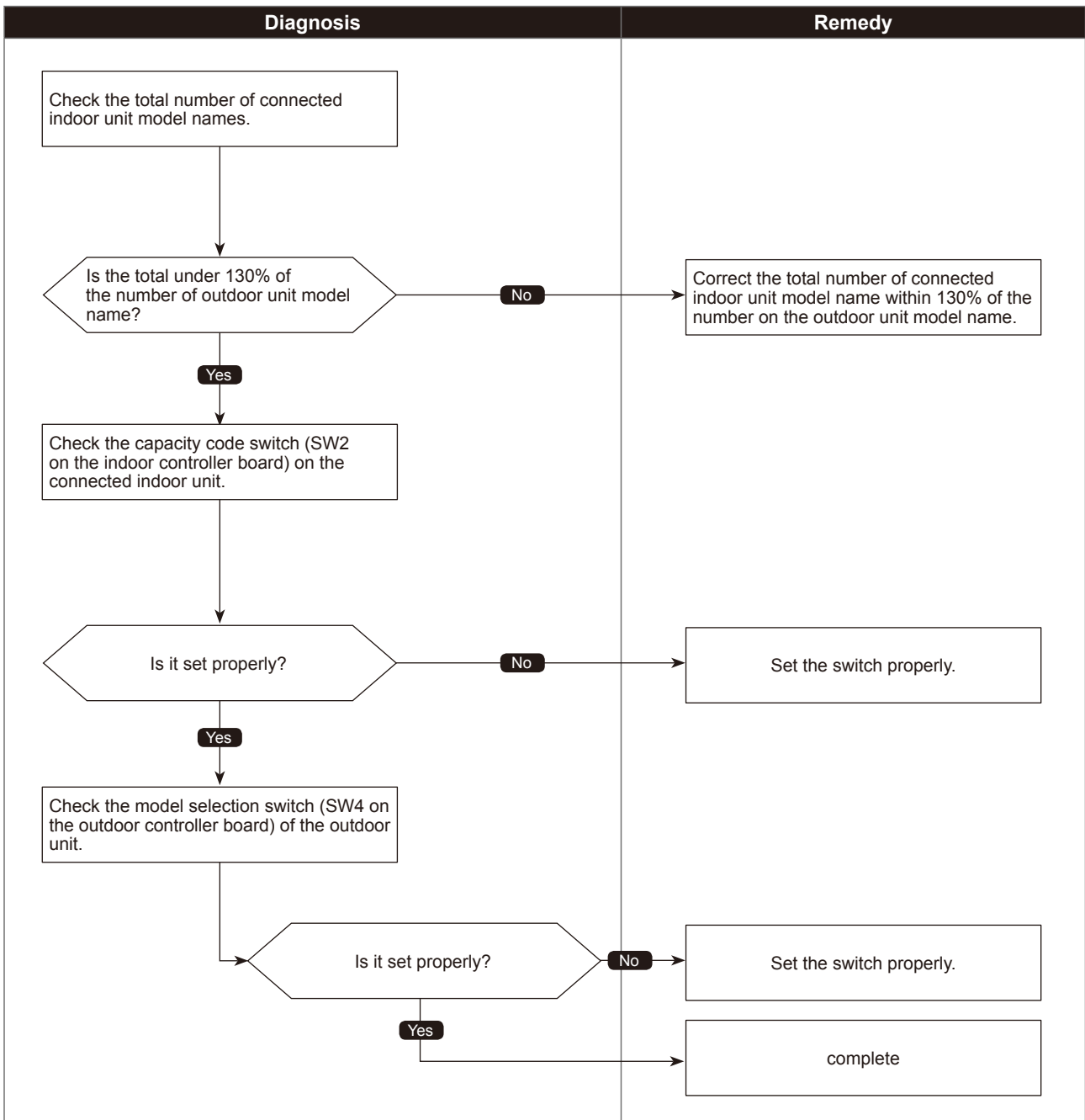

Check code

7101

Capacity code error

Abnormal points and detection methods

When a connected indoor unit is incompatible, a check code <7101> is displayed.

Causes and check points

The model name of connected indoor unit (model code) is read as incompatible.

The connectable indoor units are:

·P112 to P140 model: P15 to P140 model (code 3 to 28)

●Diagnosis of defectives

Make sure to turn the power OFF before connecting/disconnecting any connectors, or replacing boards.

Diagnosis

Check the model selection switch (SW4 on the indoor controller board) of the connected indoor unit.

Is it set properly?

No

Yes

Remedy

Set the switch properly.

The model code of the connected indoor unit can be displayed by an operation of SW1 on the outdoor unit.

Check code

7102

Connecting excessive number of units

Abnormal points and detection methods	Causes and check points
<p>When the connected AC unit exceeds the limit, a check code <7102> is displayed.</p>	<p>Connecting more AC units than the limit Abnormal if connecting status does not comply with the following limit;</p> <ul style="list-style-type: none"> ① Connectable up to 12 indoor units ② Connect at least 1 indoor unit (Abnormal if connected none) ③ Connectable only 1 ventilation unit

●Diagnosis of defectives

Make sure to turn the power OFF before connecting/disconnecting any connectors, or replacing boards.

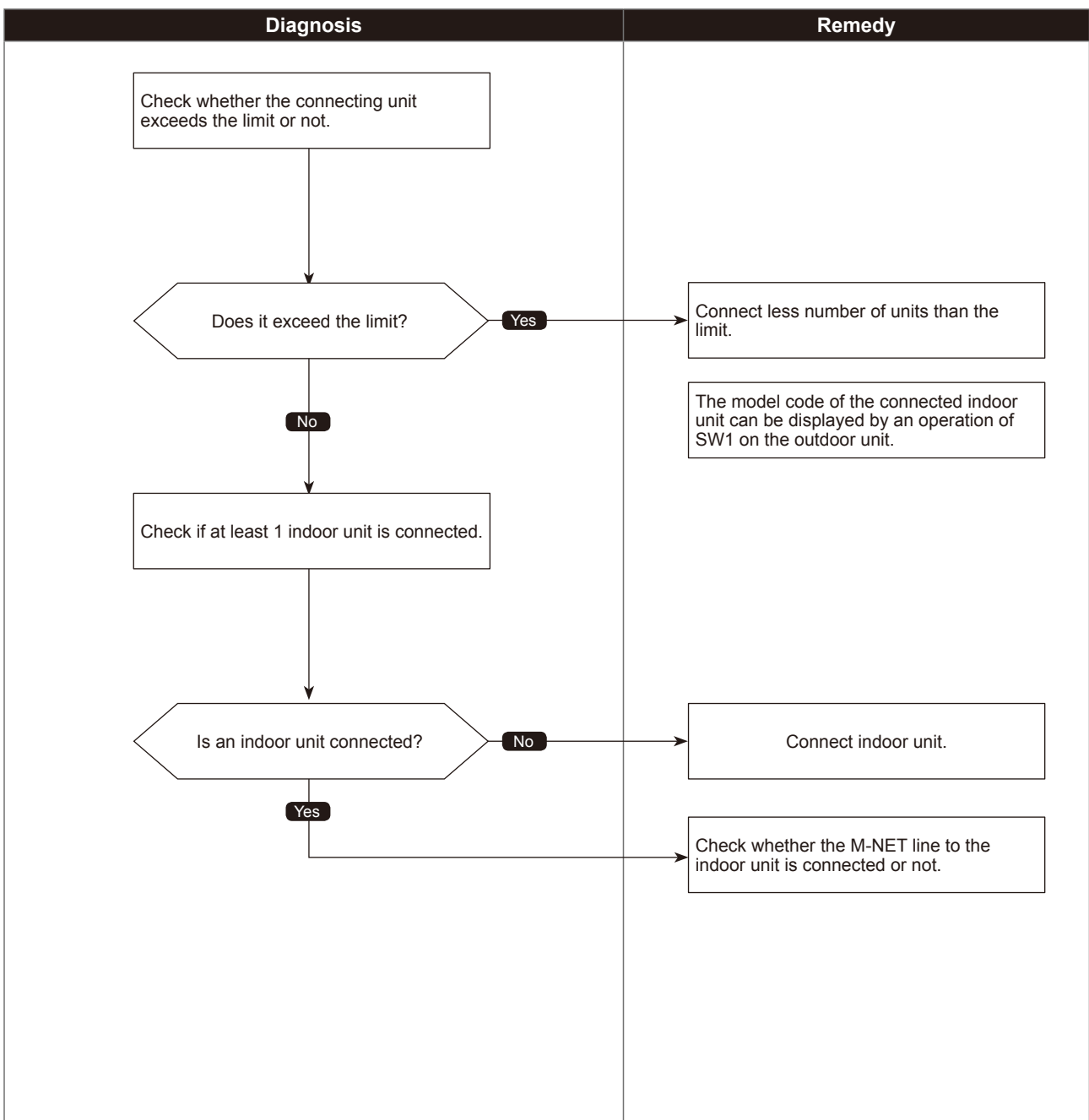

Check code

7105

Address setting error

Abnormal points and detection methods	Causes and check points
The address setting of outdoor unit is wrong.	Wrongly set address of indoor unit The outdoor unit is not set in 000, or in the range of 51 to 100.

●Diagnosis of defectives

Make sure to turn the power OFF before connecting/disconnecting any connectors, or replacing boards.

Diagnosis	Remedy

8-2. REMOTE CONTROLLER DIAGNOSIS

· For M-NET remote controller system

If the air conditioner cannot be operated from the remote controller, diagnose the remote controller as explained below.

- ① First, check that the power-on indicator is lit.
If the correct voltage (DC12 V) is not supplied to the remote controller, the indicator will not light.
If this occurs, check the remote controller's wiring and the indoor unit.

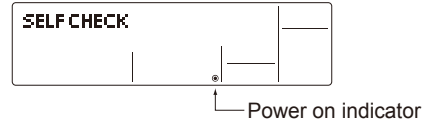

- ② Switch to the remote controller self-diagnosis mode.
Press the **CHECK** button for 5 seconds or more. The display content will change as shown below.

Press the **FILTER** button to start self-diagnosis.

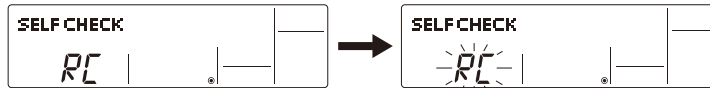

- ③ Remote controller self-diagnosis result

[When the remote controller is functioning correctly]



Check for other possible causes, as there is no problem with the remote controller.

[When the remote controller malfunctions]
(Error display 1) "NG" flashes. → The remote controller's transmitting-receiving circuit is defective.



The remote controller must be replaced with a new one.

[Where the remote controller is not defective, but cannot be operated.]
(Error display 2) [E3], [6833] or [6832] flashes. → Transmission is not possible.





There might be noise or interference on the transmission path, or the indoor unit or other remote controllers are defective. Check the transmission path and other controllers.

(Error display 3) "ERC" and the number of data errors are displayed.
→ Data error has occurred.



The number of data errors is the difference between the number of bits sent from the remote controller and the number actually transmitted through the transmission path. If such a problem is occurring, the transmitted data is affected by noise, etc. Check the transmission path.

When the number of data errors is "02":
Transmission data from remote controller 
Transmission data on transmission path 

- ④ To cancel remote controller diagnosis

Press the **CHECK** button for 5 seconds or more. Remote controller diagnosis will be cancelled, "PLEASE WAIT" and operation lamp will flash.
After approximately 30 seconds, the state in effect before the diagnosis will be restored.



· For MA remote controller system

① Select "Service" from the Main menu, and press the  button.

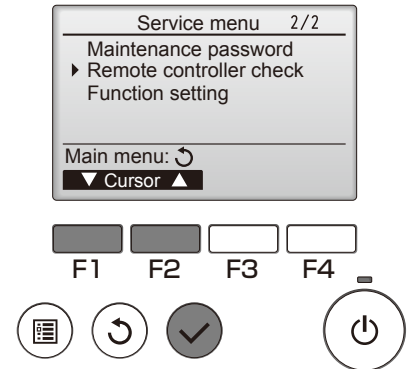
Select "Remote controller check" with the **F1** or **F2** button, and press the .



② Select "Remote controller check" from the Service menu, and press the  button to start the remote controller check and see the check results.

To cancel the remote controller check and exit the Remote controller check menu screen, press the  or the .

The remote controller will not reboot itself.

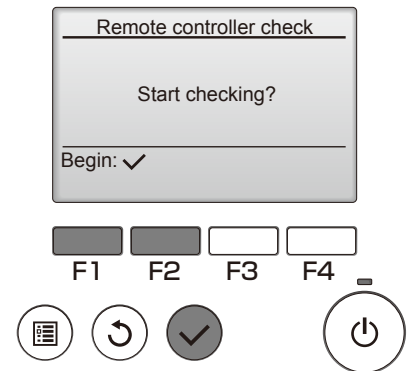

- ③
- OK:** No problems are found with the remote controller. Check other parts for problems.
 - E3, 6832:** There is noise on the transmission line, or the indoor unit or another remote controller is faulty. Check the transmission line and the other remote controllers.
 - NG (ALL0, ALL1):** Send-receive circuit fault. Remote controller needs replacing.
 - ERC:** The number of data errors is the discrepancy between the number of bits in the data transmitted from the remote controller and that of the data that was actually transmitted over the transmission line. If data errors are found, check the transmission line for external noise interference.

If the  button is pressed after the remote controller check results are displayed, remote controller check will end, and the remote controller will automatically reboot itself.

Remote controller check results screen

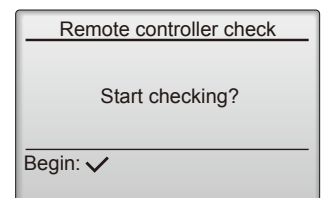

Check the remote controller display and see if anything is displayed (including lines). Nothing will appear on the remote controller display if the correct voltage (8.5 – 12 VDC) is not supplied to the remote controller. If this is the case, check the remote controller wiring and indoor units.

8-3. REMOTE CONTROLLER TROUBLE

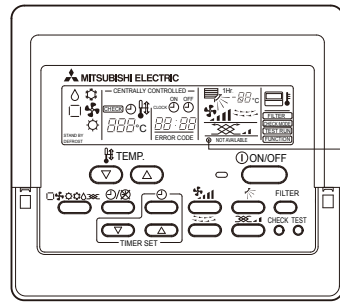

"●" Indicator: appears when current is carried.

(M-NET Remote controller)

(1) For M-NET remote controller systems

Symptom or inspection code	Cause	Inspection method and solution
Though the content of operation is displayed on the remote controller, some indoor units do not operate.	<ul style="list-style-type: none"> The power supply of the indoor unit is not on. The address of the indoor units in same group or the remote controller is not set correctly. The group setting between outdoor units is not registered to the remote controller. The fuse on the indoor unit controller board is blown. 	<ul style="list-style-type: none"> Check the part where the abnormality occurs. ① The entire system ② In the entire refrigerant system ③ In same group only ④ 1 indoor unit only
Though the indoor unit operates, the display of the remote controller goes out soon.	<ul style="list-style-type: none"> The power supply of the indoor unit is not on. The fuse on the indoor unit controller board is blown. 	<p><In case of the entire system or in the entire refrigerant system></p> <ul style="list-style-type: none"> Check the self-diagnosis LED of the outdoor unit. Check the items shown in the left that are related to the outdoor unit.
(●) is not displayed on the remote controller. (M-NET remote controller is not fed.)	<ul style="list-style-type: none"> The power supply of the outdoor unit is not on. The connector of transmission outdoor power board is not connected. The number of connected indoor unit in the refrigeration system is over the limit or the number of connected remote controller is over the limit. M-NET remote controller is connected to MA remote controller cable. The transmission line of the indoor/outdoor unit is shorted or down. M-NET remote controller cable is shorted or down. Transmission outdoor power board failure. 	<p><In case of in same group only or 1 indoor unit only></p> <ul style="list-style-type: none"> Check the items shown in the left that are related to the indoor unit.
"HO" keeps being displayed or it is displayed periodically. ("HO" is usually displayed about 3 minutes after the power supply of the outdoor unit is on.)	<ul style="list-style-type: none"> The power supply for the feeding expansion unit for the transmission line is not on. The address of the outdoor unit remains "00". The address of the indoor unit or the remote controller is not set correctly. MA remote controller is connected to the transmission line of the indoor/outdoor unit. 	
The remote controller does not operate though (●) is displayed.	<ul style="list-style-type: none"> The transmission line of the indoor/outdoor unit is connected to TB15. The transmission line of the indoor/outdoor unit is shorted, down or badly contacted. 	

(2) For MA remote controller systems

Symptom or inspection code	Cause	Inspection method and solution
Though the content of operation is displayed on the remote controller, some indoor units do not operate.	<ul style="list-style-type: none"> The power supply of the indoor unit is not on. Wiring between indoor units in same group is not finished. The indoor unit and Slim model are connected to same group. The fuse on the indoor unit controller board is blown. 	<ul style="list-style-type: none"> Check the part where the abnormality occurs. ① The entire system ② In the entire refrigerant system ③ In same group only ④ 1 indoor unit only
Though the indoor unit operates, the display of the remote controller goes out soon.	<ul style="list-style-type: none"> The power supply of the indoor unit (Master) is not on. In case of connecting the system controller, the setting of the system controller does not correspond to that of MA remote controller. The fuse on the indoor unit (Master) controller board is blown. 	<p><In case of the entire system or in the entire refrigerant system></p> <ul style="list-style-type: none"> Check the self-diagnosis LED of the outdoor unit. Check the items shown in the left that are related to the outdoor unit.
(●) is not displayed on the remote controller. (MA remote controller is not fed.)	<p>The remote controller is not fed until the power supply of both indoor unit and outdoor unit is on and the start-up of both units is finished normally.</p> <ul style="list-style-type: none"> The power supply of the indoor unit is not on. The power supply of the outdoor unit is not on. The number of connected remote controller is over the limit (Maximum: 2 units) or the number of connected indoor unit that is over the limit (Maximum: 16 units). The address of the indoor unit is "00" and the address for the outdoor unit is the one other than "00". The transmission line of the indoor/outdoor unit is connected to TB15. MA remote controller is connected to the transmission line of the indoor/outdoor unit. The remote controller cable is shorted or down. The power supply cable or the transmission line is shorted or down. The fuse on the indoor unit controller board is blown. 	<p><In case of in same group only or 1 indoor unit only></p> <ul style="list-style-type: none"> Check the items shown in the left that are related to the indoor unit.
"PLEASE WAIT" keeps being displayed or it is displayed periodically. ("PLEASE WAIT" is usually displayed about 3 minutes after the power supply of the outdoor unit is on.)	<ul style="list-style-type: none"> The power supply of the outdoor unit is not on. The power supply of the feeding expansion unit for the transmission line is not on. The setting of MA remote controller is not main remote controller, but sub-remote controller. MA remote controller is connected to the transmission line of the indoor/outdoor unit. 	
The remote controller does not operate though (●) is displayed.	<ul style="list-style-type: none"> The power supply of the indoor unit (Master) is not on. The transmission line of the indoor/outdoor unit is connected to TB15. The transmission line of the indoor/outdoor unit is shorted, down or badly contacted. The fuse on the indoor unit controller board is blown. 	



8-4. THE FOLLOWING SYMPTOM DO NOT REPRESENT TROUBLE (EMERGENCY)

Symptom	Display of remote controller	CAUSE
Even the cooling (heating) operation selection button is pressed, the indoor unit cannot be operated.	"Cooling (Heating)" blinks	The indoor unit can not cool (Heat) if other indoor units are heating (Cooling).
The auto vane runs freely.	Normal display	Because of the control operation of auto vane, it may change over to horizontal blow automatically from the downward blow in cooling in cause the downward blow operation has been continued for 1 hour. At defrosting in heating, hot adjusting and thermostat OFF, it automatically changes over to horizontal blow.
Fan setting changes during heating.	Normal display	Ultra-low speed operation is commenced at thermostat OFF. Light air automatically change over to set value by time or piping temperature at thermostat ON.
Fan stops during heating operation.	"Defrost ❄"	The fan is to stop during defrosting.
Fan does not stop while operation has been stopped.	Light out	Fan is to run for 1 minute after stopping to exhaust residual heat (only in heating).
No setting of fan while start SW has been turned on.	STAND BY ❄	Ultra-low speed operation for 5 minutes after SW ON or until piping temperature becomes 35°C. There low speed operate for 2 minutes, and then set notch is commenced. (Hot adjust control)
Indoor unit remote controller shows "HO" or "PLEASE WAIT" indicator for about 2 minutes when turning ON power supply.	"HO" blinks "PLEASE WAIT" blinks	System is being driven. Operate remote controller again after "HO" or "PLEASE WAIT" disappears.
Drain pump does not stop while unit has been stopped.	Light out	After a stop of cooling operation, unit continues to operate drain pump for 3 minutes and then stops it.
Drain pump continues to operate while unit has been stopped.	—	Unit continues to operate drain pump if drainage is generated, even during a stop.

8-5. INTERNAL SWITCH FUNCTION TABLE PUMY-P112/125/140VKM(-BS)

PUMY-P112/125/140YKM(-BS)

The black square (■) indicates a switch position.

Switch	Step	Function	Operation in Each Switch Setting		Remarks	Purpose	Additional Information	
			ON	OFF				
SWU1 1st digit	Rotary switch				<Initial settings> 			
SWU2 2nd digit	Rotary switch				<Initial settings> 			
SW1 Digital Display Switch	1-8				<Initial settings> 			
SW2 Function Switch	1	Selects operating system startup	With centralized controller	Without centralized controller	Before turning the power ON	Turn ON when the centralized controller is connected to the outdoor unit.	—	
	2	Connection Information Clear Switch	Clear	Do not clear	Before turning the power ON	When relocating units or connecting additional units.	—	
	3	Abnormal data clear switch input	Clear abnormal data	Normal	OFF to ON any time after the power is turned on.	To delete an error history.		
	4	Pump down	Run adjustment mode	Normal	During compressor running	To facilitate outdoor unit the pumping down operation. Frequency = Fixed to 65 Hz Indoor-electronic expansion valve = Fully open Outdoor fan step = Fixed to 10	Please refer to a section referring to the pumping down on outdoor units Installation Manuals. It might not be possible to collect all the refrigerant if the amount is excessive.	
	5	—	—	—	—	—	—	
	6	—	—	—	—	—	—	
SW3 Trial operation	1	ON/OFF from outdoor unit *	ON	OFF	Any time after the power is turned ON.	—	—	
	2	Mode setting	Heating	Cooling	—	—	—	
SW4/ SW8 Model Switch	1-6	MODEL SELECTION 1:ON 0:OFF				<Initial settings> Set for each capacity.	—	—
		MODELS	SW4	MODELS	SW8			
		PUMY-P112VKM	ON OFF 1 2	PUMY-P112VKM	ON OFF 1 2			
		PUMY-P125VKM	ON OFF 1 2 3 4 5 6	PUMY-P125VKM	ON OFF 1 2			
		PUMY-P140VKM	ON OFF 1 2 3 4 5 6	PUMY-P140VKM	ON OFF 1 2			
		PUMY-P112YKM	ON OFF 1 2	PUMY-P112YKM	ON OFF 1 2			
SW5 Function switch	1-6	MODEL SELECTION 1:ON 0:OFF				<Initial settings> Set for each capacity.	—	—
		MODELS	SW4	MODELS	SW8			
		PUMY-P112VKM	ON OFF 1 2	PUMY-P112VKM	ON OFF 1 2			
		PUMY-P125VKM	ON OFF 1 2 3 4 5 6	PUMY-P125VKM	ON OFF 1 2			
		PUMY-P140VKM	ON OFF 1 2 3 4 5 6	PUMY-P140VKM	ON OFF 1 2			
		PUMY-P112YKM	ON OFF 1 2	PUMY-P112YKM	ON OFF 1 2			
Demand control setting for Australia	1	Demand control setting for Australia	Australia setting	Normal**	Can be set when off or during operation	Turn ON to activate the demand control for Australia. To set the LEV opening at start-up higher than usual. (Qj < 14 + 500 pulses, 14 ≤ Qj + 75 pulses) To improve the operation with the LEV almost clogged.	(Do not turn this ON if the unit is in outside Australia) The refrigerant flow noise at start-up become louder.	
	2	Change the indoor unit's LEV opening at start-up	Enable	Normal	—	—	—	
	3	—	—	—	—	—	—	
	4	Auxiliary heater	—	—	OFF to ON during compressor running.	Turn ON when an auxiliary heater is connected. (It transmits a connection permission signal of the auxiliary heater to the connected indoor unit.)	Turn ON only when the auxiliary heater is connected and operated.	
	5	Change the indoor unit's LEV opening at defrost	Enable	Normal	Can be set when OFF or during operation	To set the LEV opening higher than usual during defrosting operation. (Only Qj ≤ 10 is valid. + 300 pulses) To avoid the discharge temperature increase and provide efficient defrosting operation.	The refrigerant flow noise during the defrosting operation become louder.	
	6	Switching the target sub cool (heating mode)	Enable	Normal	Can be set when OFF or during operation	To decrease the target sub cool value. To reduce the discharge temperature decrease due to refrigerant liquid accumulation in the units.	A refrigerant flow noise might be generated if the sub cool value is too small.	

* Test run on PWFY series cannot be run by the outdoor unit. Use a switch on the indoor unit or a remote controller to perform test run.
** Refer to "8-6. OUTDOOR UNIT INPUT/OUTPUT CONNECTOR".

The black square (■) indicates a switch position.

Switch	Step	Function	Operation in Each Switch Setting		When to Set	Remarks	Purpose	Additional Information
			ON	OFF				
SW5 function switch	7	During the outdoor unit is in HEAT operation, slightly opens the electronic expansion valve on the indoor unit which is in FAN, STOP, COOL, or thermo-OFF**.	Active	Inactive	Can be set when OFF or during operation	<Initial settings> ON ■■■■■■ OFF ■■■■■■ 1 2 3 4 5 6 7 8	To open the LEV opening higher for units other than in HEAT operation. To avoid a refrigerant shortage (less capacity) due to refrigerant liquid accumulation in the units which is not in operation.	A refrigerant flow noise might be generated in units other than the one in operation.
	8	During the outdoor unit is in operation, fully opens the electronic expansion valve on the indoor unit which is in FAN, COOL, STOP, or thermo-OFF***.	Enable	Normal	Before turning the power ON.	Before turning the power ON.	To reduce the room temperature increase by setting the LEV opening lower for the units in thermo-OFF operation.	The refrigerant is more likely to collect in the units with thermo-OFF operation, and causing the units refrigerant shortage. (Results in less capacity and increase of discharge temperature.)
SW6 function switch	1	—	—	—	—	—	—	—
	2	Switch of current limitation reading in a different way	Enable	Normal	Before turning the power ON.	<Initial settings> ON ■■■■■■ OFF ■■■■■■ 1 2 3 4 5 6	To lower the primary current limit by 3A. This switch is used for a single phase model with a breaker capacity 30A. (32A is the specified value)	The performance of the unit might be somewhat reduced since the frequency would not rise enough due to the lowered current limitation.
	3	—	—	—	—	—	—	—
	4	Change of defrosting control	Enable (For high humidity)	Normal	—	—	To shorten the defrosting prohibition time in high humidity (or heavy snow) region, in order to reduce malfunctions caused by frost.	The performance of the HEAT operation is somewhat reduced since the defrosting operation is frequently performed.
	5	Ignore refrigerant filling abnormality	Enable	Normal	Can be set when OFF or during operation	Can be set when OFF or during operation	To ignore the error detection of excessive charge of refrigerant. The unit can be excessively charged with refrigerant depending on the operating condition.	Make sure that the unit is not excessively charged with refrigerant before starting operation when servicing or installing the units.
	6	Switching the target discharge pressure (Pdm)	Enable	Normal	—	SW6-6 Target Pdm (kg/cm ²) 29.5 31.5	To raise the performance by setting the Pdm higher during HEAT operation.	Power consumption is raised due to a higher frequency. (The performance would not be raised at the maximum operating frequency.)
	7	Switching (1) the target evaporation temperature (ETm)	Enable	Normal	—	SW6-7 OFF ON OFF ON	To raise/reduce the performance by changing the target ETm during COOL operation.	Switching it to raise the performance, it raises the power consumption, and produces more dew condensation.
	8	Switching (2) the target evaporation temperature (ETm)	Enable	Normal	—	SW6-8 Target ETm (°C) 9 11 6 14	Switch to raise the performance: raises the performance Switch to reduce the performance: prevents dew condensation	Switching it to reduce the performance, it makes the performance insufficient.
SW7 function switch	1	Ignore current sensor abnormality	Enable	Normal	After turning the power ON.	<Initial settings> ON ■■■■■■ OFF ■■■■■■ 1 2 3 4 5 6	To perform a test run for electrical parts alone without running the compressor.	Make sure to connect the connectors to the compressor after checking the electrical parts. Be careful not to get electrical shock while working on electrical parts.
	2	Setting to energize the freeze stat heater (optional part)	During heating operation only****	Include when the heating operation is OFF*****	Can be set when OFF or during operation	—	It reduces snow on the base, even it blows inside the unit, by setting the base heater ON while the HEAT operation is stopped.	Power consumption raises while the operation is stopped.
	3	—	—	—	—	—	—	—
	4	Maximum frequency down at 1 hour after COOL operation	Enable	Normal	Can be set when OFF or during operation	—	To reduce dew condensation on the indoor unit by lowering the frequency.	The performance might be insufficient.
	5	—	—	—	—	—	—	—
SW9 Function Switch	1	Auto change over from remote controller (IC with the minimum address)	Enable*	Disable	During compressor running in HEAT mode.	<Initial settings> ON ■■■■■■ OFF ■■■■■■ 1 2	Turn ON when it is necessary to perform the defrosting operation forcibly. (Effective only at start-up, or 10 minutes after the last defrosting operation)	It performs the defrosting operation forcibly. (HEAT operation is stopped temporarily.)
	2	Switching the Silent/ Demand mode	Demand control	Silent mode	Before turning the power ON Can be set when OFF or during operation	—	Enables the indoor unit with the minimum address to select AUTO mode, and switches the operation mode of the other indoor units to the same mode.	Cannot be set when the centralized control is ON. About the Silent mode/Demand control setting, refer to "8-6. OUTDOOR UNIT INPUT/OUTPUT CONNECTOR".

*When a PWFY series is connected, this function is always disable regardless of the switch.

**SW5-7 Opens the indoor-electronic expansion valve as a countermeasure against the indoor unit in FAN, COOL, STOP, or thermo-OFF operation with refrigerant-shortage status due to an accumulation of liquid refrigerant in the indoor unit.

***SW5-8 Countermeasure against room temperature rise for indoor unit in FAN, COOL, and thermo-OFF (heating) mode.

****During heating operation and the ambient temperature is 4°C (39°F) or below, the freeze prevention heater is energized.

*****During heating mode is OFF (include thermo-OFF in cooling mode), and the ambient temperature is 4°C (39°F) or below, the freeze prevention heater is energized.

8-6. OUTDOOR UNIT INPUT/OUTPUT CONNECTOR

• State (CN51)

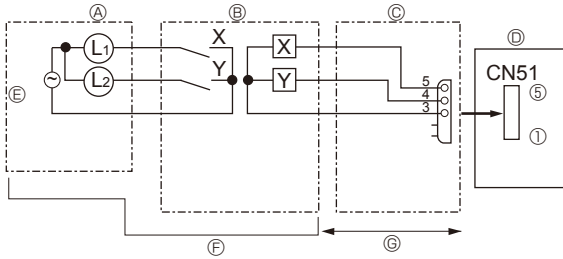

- Ⓐ Distant control board
- Ⓑ Relay circuit
- Ⓒ External output adapter (PAC-SA88HA-E)
- Ⓓ Outdoor unit control board
- Ⓔ Lamp power supply
- Ⓕ Procure locally
- Ⓖ Max. 10m

L1: Error display lamp
 L2: Compressor operation lamp
 X, Y: Relay (Coil standard of 0.9W or less for DC 12V)
 X, Y: Relay (DC1mA)

• Auto change over (CN3N)

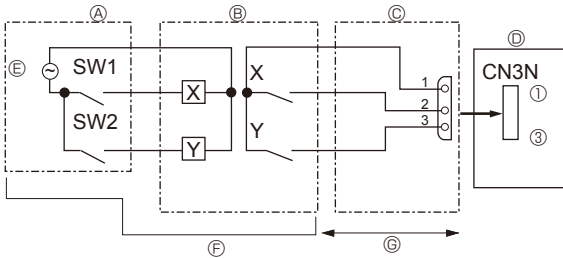

- Ⓐ Remote control panel
- Ⓑ Relay circuit
- Ⓒ External input adapter (PAC-SC36NA-E)
- Ⓓ Outdoor unit control board
- Ⓔ Relay power supply
- Ⓕ Procure locally
- Ⓖ Max. 10 m

	ON	OFF
SW1	Heating	Cooling
SW2	Validity of SW1	Invalidity of SW1

• Silent Mode / Demand Control (CN3D)

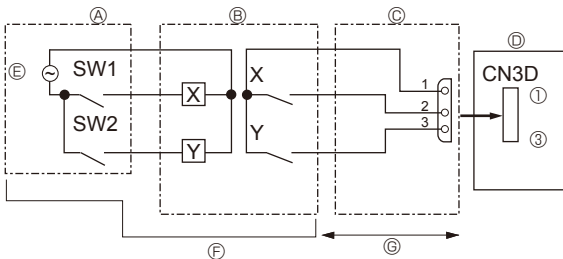

- Ⓐ Remote control panel
- Ⓑ Relay circuit
- Ⓒ External input adapter (PAC-SC36NA-E)
- Ⓓ Outdoor unit control board
- Ⓔ Relay power supply
- Ⓕ Procure locally
- Ⓖ Max. 10 m

The silent mode and the demand control are selected by switching the DIP switch 9-2 on outdoor controller board. It is possible to set it to the following power consumption (compared with ratings) by setting SW1, 2.

	Outdoor controller board DIP SW9-2	SW1	SW2	Function
Silent mode	OFF	ON	—	Silent mode operation
Demand control	ON	OFF	OFF	100% (Normal)
		ON	OFF	75%
		ON	ON	50%
		OFF	ON	0% (Stop)

8-7. HOW TO CHECK THE PARTS

PUMY-P112VKM(-BS)

PUMY-P112YKM(-BS)

PUMY-P125VKM(-BS)

PUMY-P125YKM(-BS)

PUMY-P140VKM(-BS)

PUMY-P140YKM(-BS)

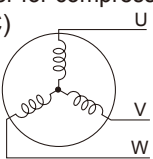
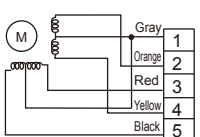
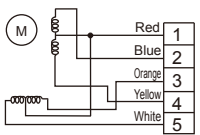
Parts name	Check points														
Thermistor (TH3) <Outdoor liquid pipe> Thermistor (TH4) <Discharge> <Compressor> Thermistor (TH6) <Suction pipe> Thermistor (TH7) <Ambient> Thermistor (TH8) <Heat Sink>	Disconnect the connector then measure the resistance with a tester. (At the ambient temperature 10 °C to 30 °C) <table border="1" style="margin-top: 10px;"> <thead> <tr> <th></th> <th>Normal</th> <th>Abnormal</th> </tr> </thead> <tbody> <tr> <td>TH4</td> <td>160 kΩ to 410 kΩ</td> <td rowspan="4">Open or short</td> </tr> <tr> <td>TH3</td> <td rowspan="2">4.3 kΩ to 9.6 kΩ</td> </tr> <tr> <td>TH6</td> </tr> <tr> <td>TH7</td> </tr> <tr> <td>TH8*</td> <td>39 kΩ to 105 kΩ</td> <td></td> </tr> </tbody> </table> <p style="text-align: right; margin-top: 10px;">* TH8 is internal thermistor of power module. (Y)</p>		Normal	Abnormal	TH4	160 kΩ to 410 kΩ	Open or short	TH3	4.3 kΩ to 9.6 kΩ	TH6	TH7	TH8*	39 kΩ to 105 kΩ		
	Normal	Abnormal													
TH4	160 kΩ to 410 kΩ	Open or short													
TH3	4.3 kΩ to 9.6 kΩ														
TH6															
TH7															
TH8*	39 kΩ to 105 kΩ														
Fan motor (MF1, MF2)	Refer to next page.														
Solenoid valve coil <Four-way valve> (21S4)	Measure the resistance between the terminals with a tester. (At the ambient temperature 20 °C) <table border="1" style="margin-top: 10px;"> <thead> <tr> <th>Normal</th> <th>Abnormal</th> </tr> </thead> <tbody> <tr> <td>1725 ± 172.5 Ω</td> <td>Open or short</td> </tr> </tbody> </table>	Normal	Abnormal	1725 ± 172.5 Ω	Open or short										
Normal	Abnormal														
1725 ± 172.5 Ω	Open or short														
Motor for compressor (MC) 	Measure the resistance between the terminals with a tester. (Winding temperature 20 °C) <table border="1" style="margin-top: 10px;"> <thead> <tr> <th colspan="2">Normal</th> <th rowspan="2">Abnormal</th> </tr> <tr> <th>PUMY-P•VKM</th> <th>PUMY-P•YKM</th> </tr> </thead> <tbody> <tr> <td>0.305 Ω</td> <td>0.466 Ω</td> <td>Open or short</td> </tr> </tbody> </table>	Normal		Abnormal	PUMY-P•VKM	PUMY-P•YKM	0.305 Ω	0.466 Ω	Open or short						
Normal		Abnormal													
PUMY-P•VKM	PUMY-P•YKM														
0.305 Ω	0.466 Ω	Open or short													
Solenoid valve coil <Bypass valve> (SV1)	Measure the resistance between the terminals with a tester. (At the ambient temperature 20 °C) <table border="1" style="margin-top: 10px;"> <thead> <tr> <th>Normal</th> <th>Abnormal</th> </tr> </thead> <tbody> <tr> <td>1182.5 ± 83 Ω</td> <td>Open or short</td> </tr> </tbody> </table>	Normal	Abnormal	1182.5 ± 83 Ω	Open or short										
Normal	Abnormal														
1182.5 ± 83 Ω	Open or short														
Linear expansion Valve (LEV A) 	<table border="1" style="margin-top: 10px;"> <thead> <tr> <th colspan="4">Normal</th> <th rowspan="2">Abnormal</th> </tr> <tr> <th>Gray - Black</th> <th>Gray - Red</th> <th>Gray - Yellow</th> <th>Gray - Orange</th> </tr> </thead> <tbody> <tr> <td colspan="4" style="text-align: center;">46 ± 3 Ω</td> <td>Open or short</td> </tr> </tbody> </table>	Normal				Abnormal	Gray - Black	Gray - Red	Gray - Yellow	Gray - Orange	46 ± 3 Ω				Open or short
Normal				Abnormal											
Gray - Black	Gray - Red	Gray - Yellow	Gray - Orange												
46 ± 3 Ω				Open or short											
Linear expansion Valve (LEV B) 	<table border="1" style="margin-top: 10px;"> <thead> <tr> <th colspan="4">Normal</th> <th rowspan="2">Abnormal</th> </tr> <tr> <th>Red - White</th> <th>Red - Orange</th> <th>Red - Yellow</th> <th>Red - Blue</th> </tr> </thead> <tbody> <tr> <td colspan="4" style="text-align: center;">46 ± 4 Ω</td> <td>Open or short</td> </tr> </tbody> </table>	Normal				Abnormal	Red - White	Red - Orange	Red - Yellow	Red - Blue	46 ± 4 Ω				Open or short
Normal				Abnormal											
Red - White	Red - Orange	Red - Yellow	Red - Blue												
46 ± 4 Ω				Open or short											

Check method of DC fan motor (fan motor/outdoor controller circuit board)

① Notes

- High voltage is applied to the connector (CNF1, 2) for the fan motor. Pay attention to the service.
- Do not pull out the connector (CNF1, 2) for the motor with the power supply on.
(It causes trouble of the outdoor controller circuit board and fan motor.)

② Self check

Symptom : The outdoor fan cannot turn around.

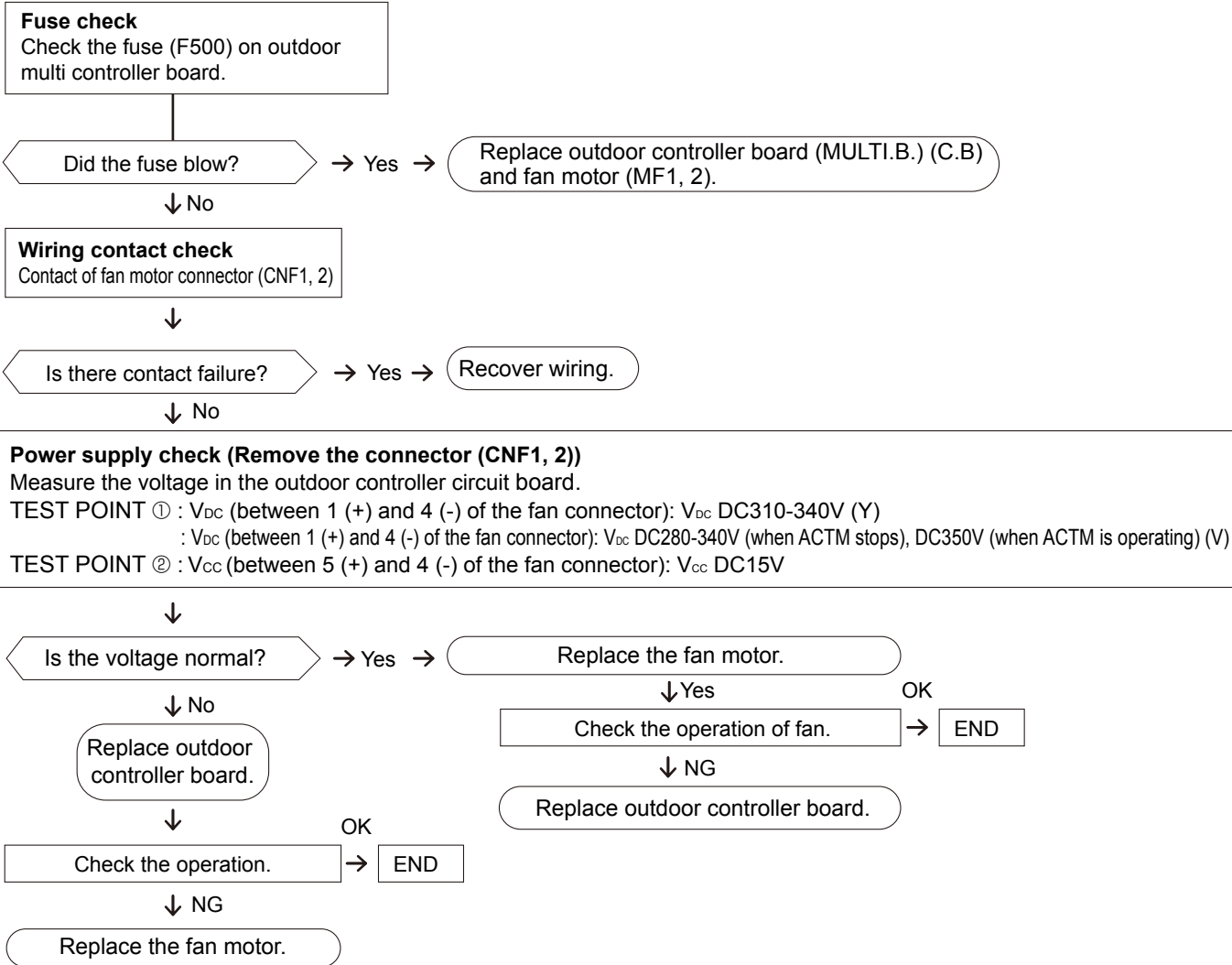

8-8. HOW TO CHECK THE COMPONENTS

<Thermistor feature chart>

Low temperature thermistors

- Thermistor <HIC pipe> (TH2)
- Thermistor <Outdoor liquid pipe> (TH3)
- Thermistor <Suction pipe> (TH6)
- Thermistor <Ambient> (TH7)

Thermistor R0 = 15 kΩ ± 3 %
B constant = 3480 ± 2 %

$$R_t = 15 \exp\left\{3480 \left(\frac{1}{273+t} - \frac{1}{273}\right)\right\}$$

0 °C	15 kΩ	30 °C	4.3 kΩ
10 °C	9.6 kΩ	40 °C	3.0 kΩ
20 °C	6.3 kΩ		
25 °C	5.2 kΩ		

Medium temperature thermistor (Only YKM)

- Thermistor <Heat sink> (TH8)

Thermistor R50 = 17 kΩ ± 2 %
B constant = 4170 ± 3 %

$$R_t = 17 \exp\left\{4170 \left(\frac{1}{273+t} - \frac{1}{323}\right)\right\}$$

0 °C	180 kΩ
25 °C	50 kΩ
50 °C	17 kΩ
70 °C	8 kΩ
90 °C	4 kΩ

High temperature thermistor

- Thermistor <Compressor> (TH4)

Thermistor R120 = 7.465 kΩ ± 2 %
B constant = 4057 ± 2 %

$$R_t = 7.465 \exp\left\{4057 \left(\frac{1}{273+t} - \frac{1}{393}\right)\right\}$$

20 °C	250 kΩ	70 °C	34 kΩ
30 °C	160 kΩ	80 °C	24 kΩ
40 °C	104 kΩ	90 °C	17.5 kΩ
50 °C	70 kΩ	100 °C	13.0 kΩ
60 °C	48 kΩ	110 °C	9.8 kΩ

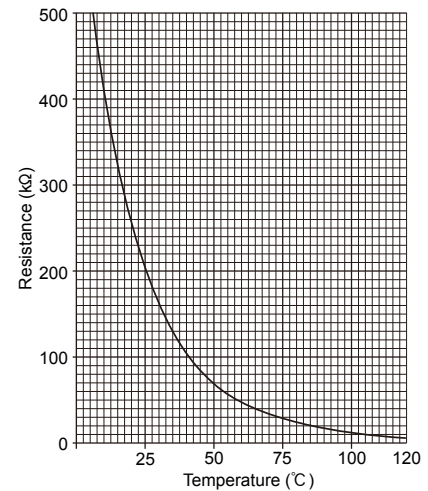
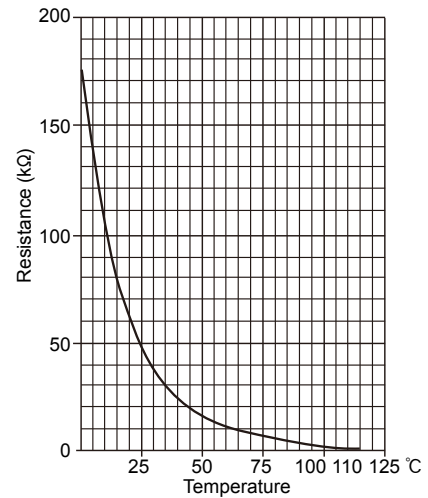
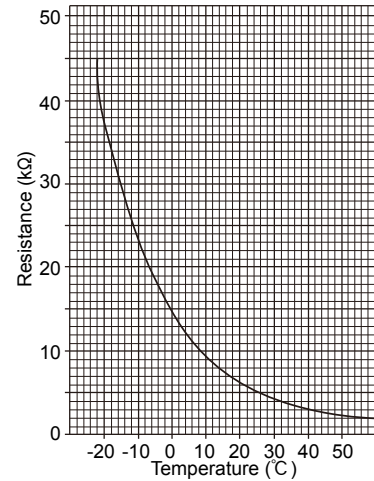

<HIGH PRESSURE SENSOR>

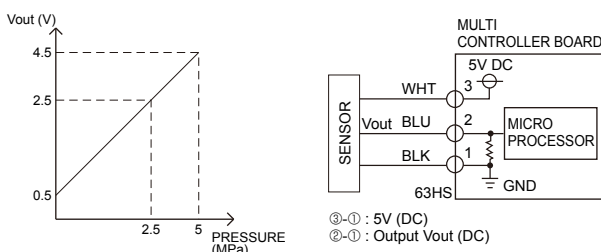

<LOW PRESSURE SENSOR>

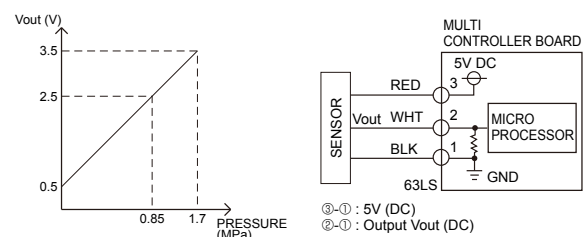

8-9. TEST POINT DIAGRAM

Outdoor multi controller board

PUMY-P112VKM(-BS)
PUMY-P125VKM(-BS)
PUMY-P140VKM(-BS)

PUMY-P112YKM(-BS)
PUMY-P125YKM(-BS)
PUMY-P140YKM(-BS)

<CAUTION> TEST POINT ① is high voltage.

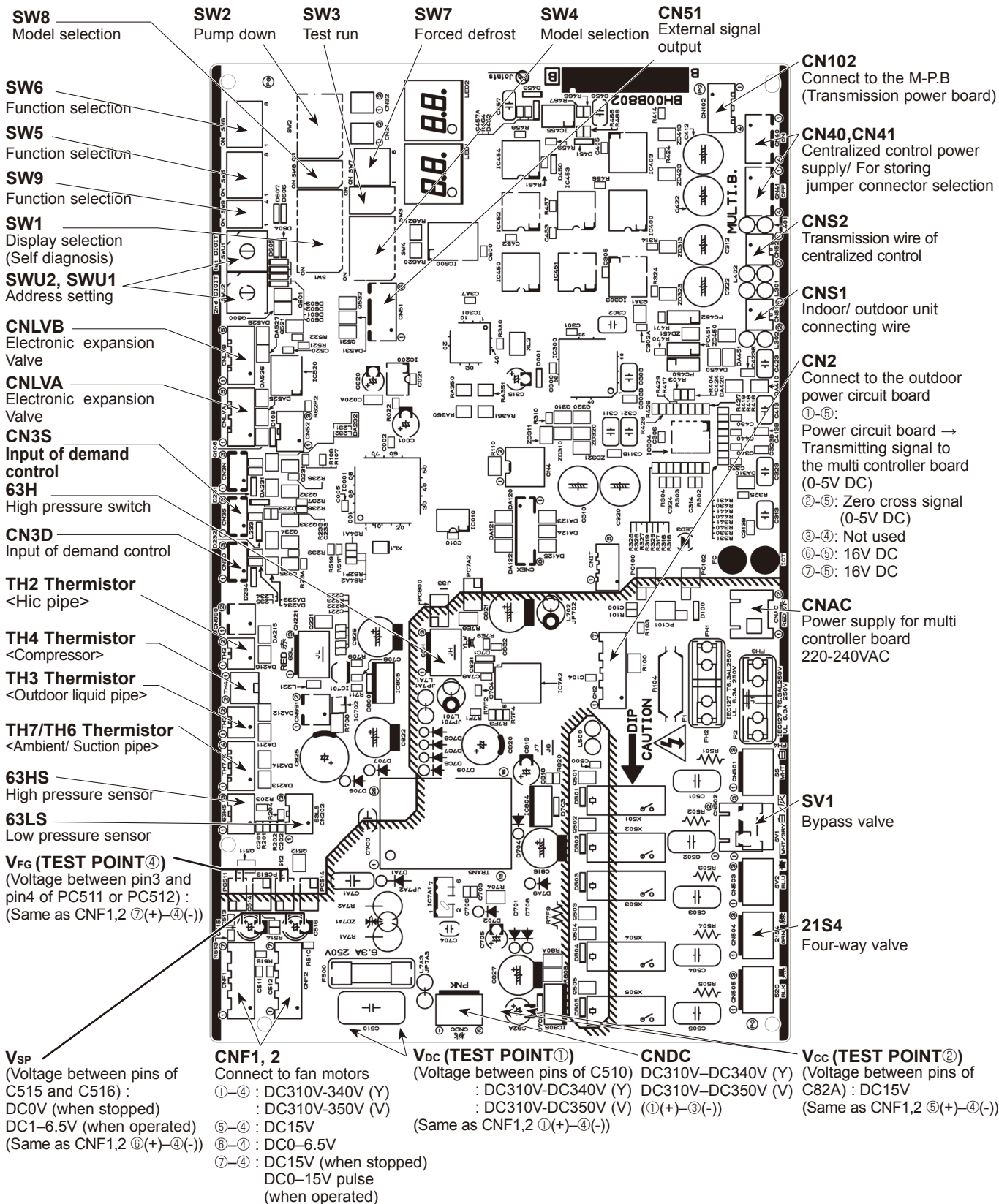

Outdoor power circuit board
PUMY-P112VKM(-BS)
PUMY-P125VKM(-BS)
PUMY-P140VKM(-BS)

Brief Check of POWER MODULE

Usually, they are in a state of being short-circuited if they are broken. Measure the resistance in the following points (connectors, etc.). If they are short-circuited, it means that they are broken.

1. Check of POWER MODULE

① Check of DIODE circuit

R-**L1**, **S**-**L1**, **R**-**N1**, **S**-**N1**

② Check of IGBT circuit

L2-**N1**

③ Check of INVERTER circuit

P-**U**, **P**-**V**, **P**-**W**, **N1**-**U**, **N1**-**V**, **N1**-**W**

Note: The marks **R**, **S**, **L1**, **L2**, **P**, **N1**, **U**, **V** and **W** shown in the diagram are not actually printed on the board.

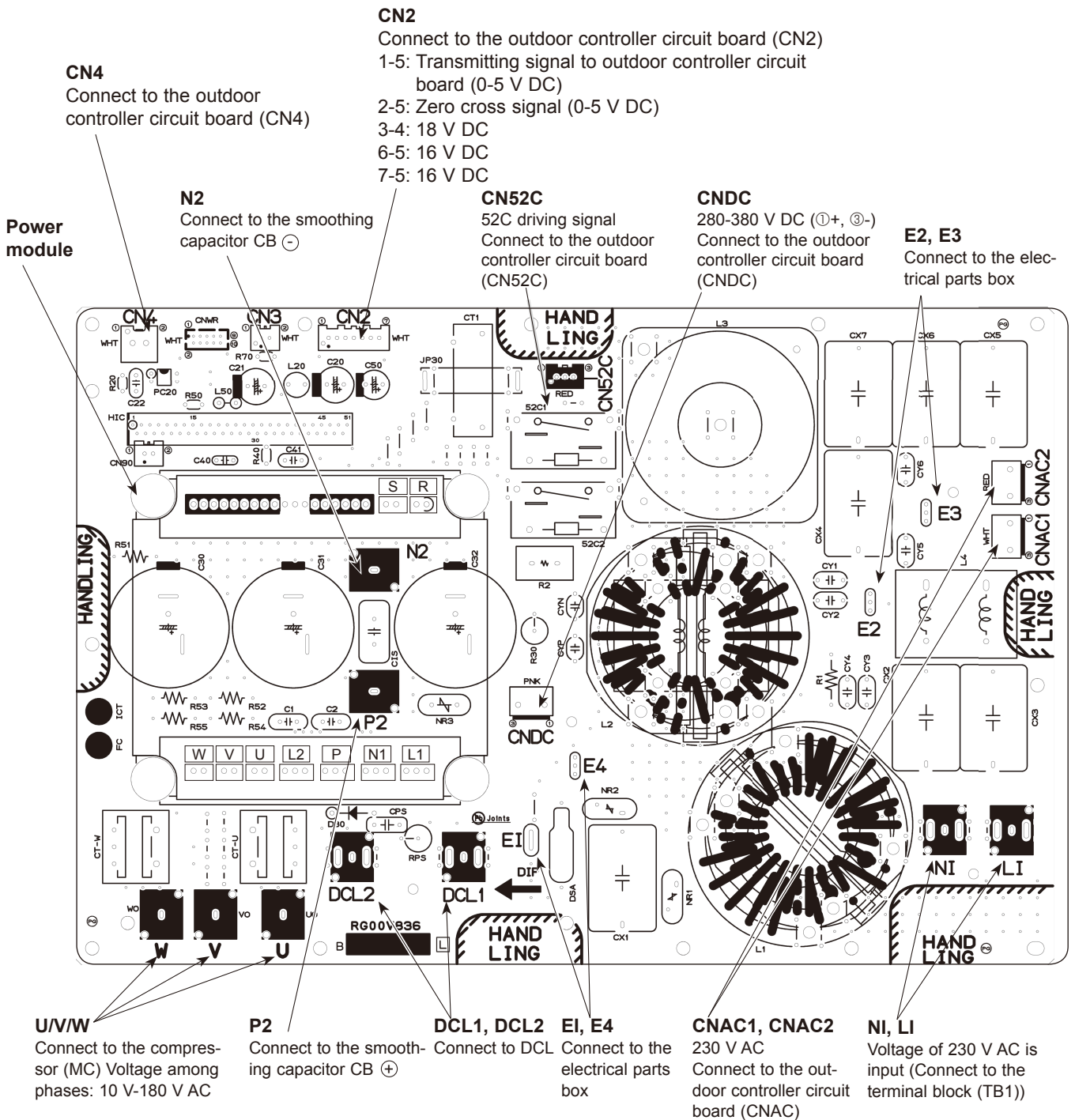

Outdoor power circuit board
PUMY-P112YKM(-BS)
PUMY-P125YKM(-BS)
PUMY-P140YKM(-BS)

Brief Check of POWER MODULE

Usually, they are in a state of being short-circuited if they are broken. Measure the resistance in the following points (connectors, etc.). If they are short-circuited, it means that they are broken.

1. Check of DIODE MODULE

L1 - P1, L2 - P1, L3 - P1, L1 - N1, L2 - N1, L3 - N1

2. Check of DIP-IPM

P2 - U, P2 - V, P2 - W, N2 - U, N2 - V, N2 - W

Note: The marks L1, L2, L3, N1, N2, P1, P2, U, V and W shown in the diagram are not actually printed on the board.

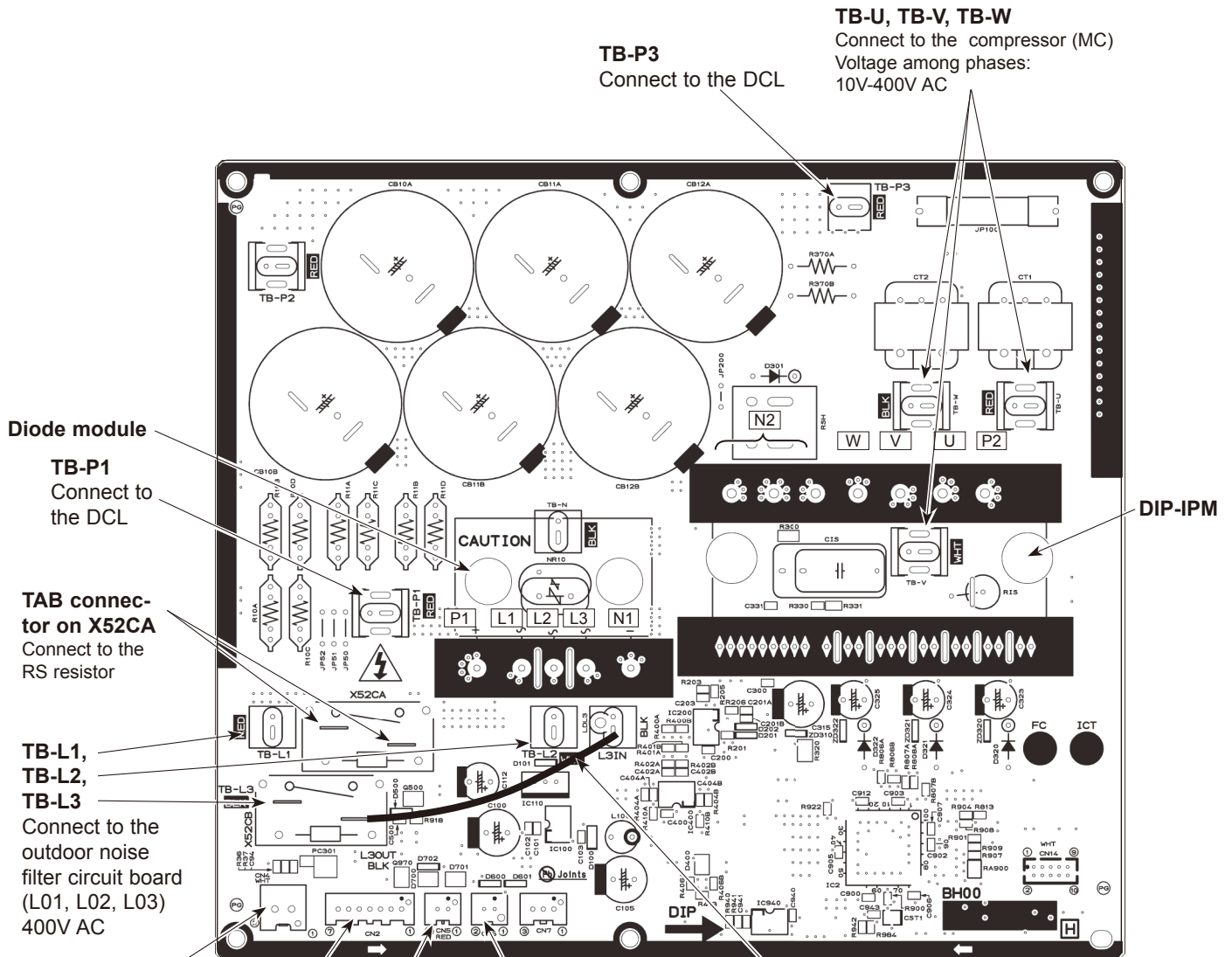

Diode module

TB-P1
Connect to the DCL

TAB connector on X52CA
Connect to the RS resistor

TB-L1, TB-L2, TB-L3
Connect to the outdoor noise filter circuit board (L01, L02, L03) 400V AC

CN4
Connect to the outdoor controller circuit board (CN4)

CN2
Connect to the outdoor controller circuit board (CN2)

- ①-⑤: Power circuit board → Transmitting signal to the controller board (0-5V DC)
- ②-⑥: Zero cross signal (0-5V DC)
- ③-④: Not used
- ⑥-⑤: 16V DC
- ⑦-⑥: 16V DC

[⑤ : ⊖ ①, ②, ⑥, ⑦ : ⊕]

TB-P3
Connect to the DCL

TB-U, TB-V, TB-W
Connect to the compressor (MC)
Voltage among phases:
10V-400V AC

DIP-IPM

L3OUT-L3IN
Lead connect

CN6
Thermistor
<Heat Sink> (TH8)

Transmission power board

PUMY-P112VKM(-BS)
 PUMY-P125VKM(-BS)
 PUMY-P140VKM(-BS)

PUMY-P112YKM(-BS)
 PUMY-P125YKM(-BS)
 PUMY-P140YKM(-BS)

CN2
 Connect to the outdoor multi controller board
 ①-②: 24-30V DC
 ③-④: 24-30V DC

TB1
 Connect to the electrical parts box

CN1
 Connect to the outdoor noise filter circuit board
 ①-③ : 220-240V AC

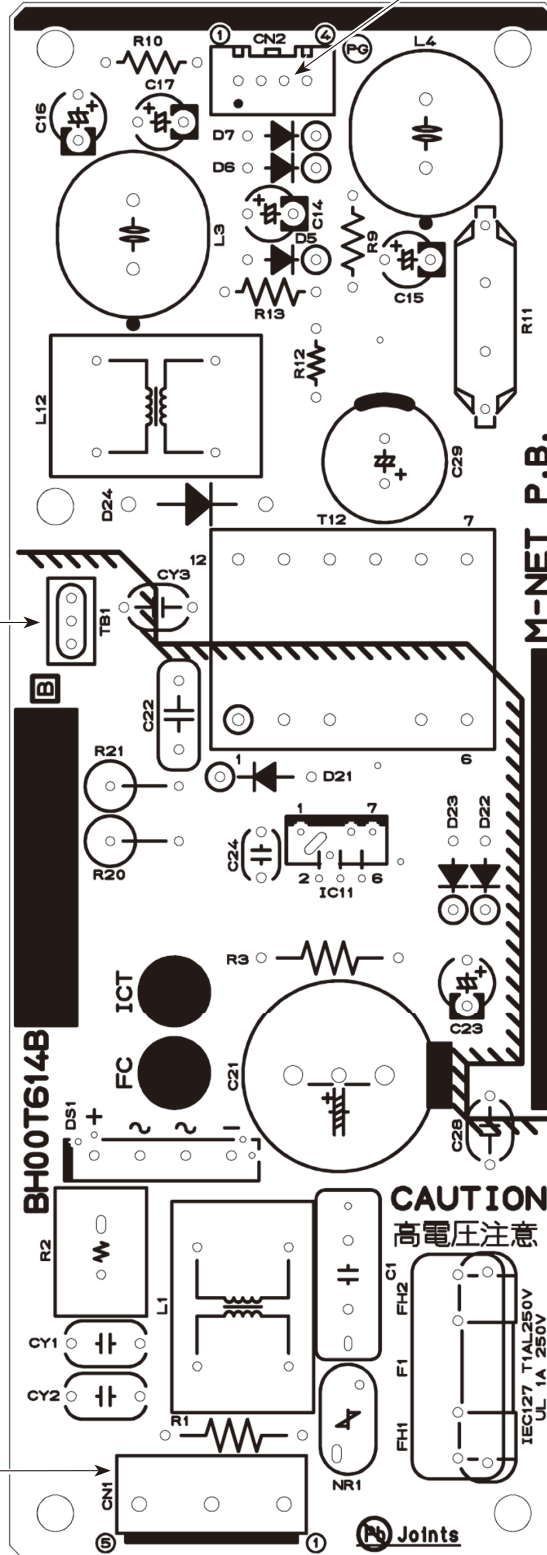

Outdoor noise filter circuit board
PUMY-P112YKM(-BS)
PUMY-P125YKM(-BS)
PUMY-P140YKM(-BS)

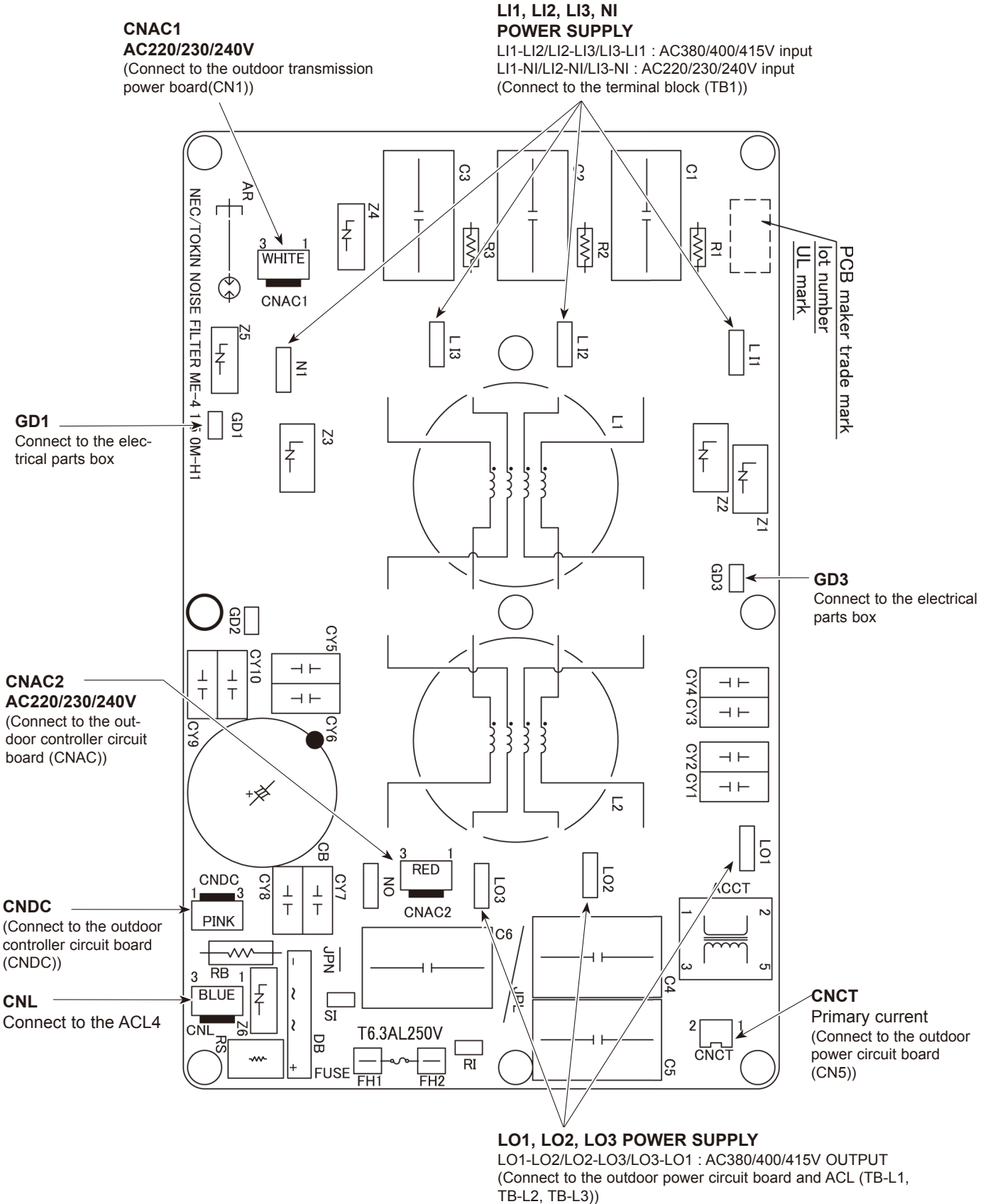

8-10. OUTDOOR UNIT FUNCTIONS

SW:setting
0...:OFF
1...:ON

No.	SW1 setting	Display on the LED1, 2 (display data)								Notes
		1	2	3	4	5	6	7	8	
0	00000000	Relay output display	52C	21S4	SV1	(SV2)			Always lighting	ON: light on OFF: light off
1	10000000	Check display	0000~9999 (Alternating display of addresses and error code)	No.3 unit check	No.4 unit check	No.5 unit check	No.6 unit check	No.7 unit check	No.8 unit check	*When abnormality occurs, check display. Check: light on Normal: light off
2	01000000	Indoor unit check status	LEV lock abnormality	Discharge/Comp. temperature abnormality	TH4 abnormality	TH3 abnormality	Outdoor fan rotation frequency abnormality	TH7 abnormality	TH8 abnormality	
3	01000000	Protection input	Over current interception	Voltage abnormality	Insufficient refrigerant amount abnormality	Current sensor abnormality	Low-pressure abnormality	63HS abnormality	start over current interception abnormality delay	Display input microprocessor protection (abnormality)
4	00100000	Protection input	"Address double setting abnormality"	Indoor unit capacity error	Over capacity	Indoor unit address error	Outdoor unit address error	Current sensor open/short	serial communication abnormality	
5	10100000	Abnormality delay display 1	LEV lock abnormality delay	"Discharge/Comp. temperature abnormality delay"	TH4 abnormality delay	TH3 abnormality delay	Outdoor fan rotation frequency abnormality delay	TH7 abnormality delay	"TH8 abnormality delay"	
6	01100000	Abnormality delay display 2	Over current interception delay	Voltage abnormality delay	Insufficient refrigerant amount abnormality delay	Current sensor abnormality delay	Low-pressure abnormality delay	63HS abnormality delay	start over current interception abnormality delay	
7	11100000	Abnormality delay display 3	HIC abnormality delay	4-way valve abnormality delay	Frozen protection delay	Power module abnormality delay	TH6 abnormality delay	Current sensor open/short delay		
8	00010000	Abnormality delay history 1	LEV lock abnormality delay	"Discharge/Comp. temperature abnormality delay"	TH4 abnormality delay	TH3 abnormality delay	Outdoor fan rotation frequency abnormality delay	TH7 abnormality delay	"TH8 abnormality delay"	
9	10010000	Abnormality delay history 2	Over current interception delay	Voltage abnormality delay	Insufficient refrigerant amount abnormality delay	Current sensor abnormality delay	Low-pressure abnormality delay	63HS abnormality delay	start over current interception abnormality delay	
10	01010000	Abnormality delay history 3	HIC abnormality delay	4-way valve abnormality delay	Frozen protection delay	Power module abnormality delay	TH6 abnormality delay	Current sensor open/short delay		
11	11010000	"Abnormality code history 1 (the latest)"			Abnormality delay	Abnormality delay	Delay code	Abnormality delay		
12	00110000	Abnormality code history 2			Discharge/Comp. temperature abnormality	Discharge/Comp. temperature sensor (TH4) abnormality	1402	High-pressure abnormality		
13	10110000	Abnormality code history 3			Discharge/Comp. temperature sensor (TH4) abnormality	Thermistor <Outdoor liquid pipe> (TH3) abnormality	1205	Pressure sensor (63HS) abnormality		"* Display abnormalities up to present (including abnormality terminals)
14	01110000	Abnormality code history 4			Thermistor <Outdoor liquid pipe> (TH3) abnormality	Saturation temperature of suction pressure sensor (TH6) abnormality	1211	Over charge refrigerant abnormality		• History record in 1 is the latest; records become older in sequence; history record in 10 is the oldest."
15	11110000	Abnormality code history 5	"Alternating display of addresses 0000-9999 and abnormality code (including abnormality delay code)"		Saturation temperature of suction pressure sensor (TH6) abnormality	Radiator panel thermistor (TH8) abnormality	1214	Insufficient refrigerant abnormality		
16	00001000	Abnormality code history 6			Radiator panel thermistor (TH8) abnormality	Outside air temperature sensor (TH7) abnormality	4320	Frequency converter insufficient wiring voltage abnormality		
17	10001000	Abnormality code history 7			Outside air temperature sensor (TH7) abnormality		4330	Heat Sink temperature abnormality		
18	01001000	Abnormality code history 8					4350	power module abnormality		
19	11001000	Abnormality code history 9								
20	00101000	Abnormality code history 10 (the oldest)								
21	10101000	Cumulative time	0~9999 (unit: 1-hour)							Display of cumulative compressor operating time
22	01101000	Cumulative time	0~9999 (unit: 10-hour)							
23	11101000	Outdoor unit operation display	Excitation Current	Restart after: 3 minutes	Abnormality(detection)	Compressor operation				"Cooling: light on, Heating: light blinking Stop fan: light off"
24	00011000	Indoor unit operation mode	No. 1 unit mode	No. 2 unit mode	No. 3 unit mode	No. 4 unit mode	No. 5 unit mode	No. 6 unit mode	No. 7 unit mode	No. 8 unit mode
25	10011000	Indoor unit operation display	No. 1 unit operation	No. 2 unit operation	No. 3 unit operation	No. 4 unit operation	No. 5 unit operation	No. 6 unit operation	No. 7 unit operation	No. 8 unit operation
26	01011000	Capacity code (No. 1 indoor unit)								
27	11011000	Capacity code (No. 2 indoor unit)								"*Display of indoor unit capacity code
28	00111000	Capacity code (No. 3 indoor unit)								•The No. 1 unit will start from the address with the lowest number"
29	10111000	Capacity code (No. 4 indoor unit)								
30	01111000	Capacity code (No. 5 indoor unit)								

No.	SW1 setting	Display mode	Display on the LED1, 2 (display data)								Notes			
			1	2	3	4	5	6	7	8				
31	11111000	IC1 operation mode												
32	00000100	IC2 operation mode												
33	10000100	IC3 operation mode												
34	01000100	IC4 operation mode												
35	11000100	IC5 operation mode												
36	00100100	OC operation mode												
37	10100100	External connection status	P07:Autochange over permission CN3N1-3 input	Heating/Cooling mode CN3N1-2 input	Abnormal/normal P95:Undefined CN3S1-2 input	DEFROST/NO P94:Demand CN3D1-3 input	Refrigerant pull back/no "P93:Silent CN3D1-2 input"	Excitation current/no	3-min.delay/no					Light on/light off Input: light off No input: light on display of communication demand capacity
38	01100100	Communication demand capacity	0~255											
39	11100100	Number of compressor ON/OFF	0000~9999 (unit: x10)											
40	00010100	Compressor operating current	0~999.9 (A)											
41	10010100	Input current of outdoor unit	0~999.9 (A)											
42	01010100	Thermo-ON operating time	0000~9999 (unit: x10)											
43	11010100	Total capacity of thermo-ON	0~255											
44	00110100	Number of indoor units	0~255											
45	10110100	DC bus voltage	0~999.9 (V)											
46	01110100	State of LEV control	"Td over heat prevention"	"SHd decrease prevention"	"Min.Si correction depends on Td"	"Min.Si correction depends on Shd"	"LEV opening correction depends on Pd"	"LEV opening correction depends on Td"	"Correction of high compression ratio prevention"					
47	11110100	"State of compressor frequency control 1"	Discharge pressure control	Compressor temperature control	"Secondary current control"	"Input current control"	"Min.Si correction depends on Td"	Discharge temp. (heating) backup	"Pd abnormality control (heating)"	Pd Back up (heating)	Low pressure decrease prevention	Frozen protection	"Freeze prevention control"	
48	00001100	"State of compressor frequency control 2"	"Heat Sink over heat prevention control"	63L S abnormality	HIC abnormality			"Frequency restrain of receipt voltage change"	4-way valve disconnection abnormality	SHd control	TH6 abnormality	"Power module abnormality"		
49	10001100	Protection input												
50	01001100	The second current value when microprocessor of POWER BOARD abnormality is detected"	0~999.9(Arms)											
51	11001100	"The radiator panel temperature when microprocessor of POWER BOARD abnormality is detected"	-99.9~999.9 (Short/Open: -99.9 or 999.9)											

Content	Content
State of compressor frequency(Hz) control (Words)	Hz control by pressure limitation
Discharge pressure control	Hz control by discharge temperature limitation
Compressor temperature control	Hz control by bypass valve
SV control	Control that restrains abnormal rise of discharge pressure
Abnormal rise of Pd control	Heat Sink over heat prevention control
Heat Sink over heat prevention control	Secondary current control
Secondary current control	Input current control
Input current control	Max.Hz correction control due to voltage decrease
Hz correction of receipt voltage decrease prevention	Max.Hz correction control due to receipt voltage change
Hz restrain of receipt voltage change	

No.	SW1 setting	Display mode	Display on the LED1, 2 (display data)								Notes	
			1	2	3	4	5	6	7	8		
52	00101100	Outdoor LEV-A opening pulse										Display of opening pulse of outdoor LEV
53	10101100	Outdoor LEV-A opening pulse abnormality delay										
54	01101100	Outdoor LEV-A opening pulse abnormality										
55	11101100	Outdoor LEV-B opening pulse	0~2000									
56	00011100	Outdoor LEV-B opening pulse abnormality delay										
57	10011100	Outdoor LEV-B opening pulse abnormality										
58	01011100	*63LS (Low-pressure)kgf/cm ²										
59	11011100	63LS abnormality delay										
60	00111100	63 LS abnormality										
61	10111100	TH2 (HIC pipe) °C	-99.99~999.9									Display of data from sensor and thermistor
62	01111100	TH2(HIC) abnormality delay										
63	11111100	TH2(HIC) abnormality										
64	00000010	Operational frequency	0~FF (16 progressive)									Display of actual operating frequency
65	10000010	Target frequency	0~255									
66	01000010	Outdoor fan control step number	0~15									Display of number of outdoor fan control steps (target)
69	10100010	IC1 LEV Opening pulse										
70	01100010	IC2 LEV Opening pulse										
71	11100010	IC3 LEV Opening pulse	0~2000									
72	00010010	IC4 LEV Opening pulse										
73	10010010	IC5 LEV Opening pulse										
74	01010010	High-pressure sensor (Pi)kgf/cm ²										"Display of outdoor subcool (SC) data and detection data from high-pressure sensor and each thermistor"
75	11010010	TH4 (Td) °C										
76	00110010	TH6 (ET) °C	-99.9 ~ 999.9									"Display of outdoor subcool (SC) data" (When indoor unit is not connected, it is displayed as "0".)
77	10110010	TH7 (Outdoor-temp) °C										
78	01110010	TH3 (Outdoor pipe) °C										
80	00001010	TH8 (Power module) °C										
81	10001010	IC1 TH23 (Gas) °C										
82	01001010	IC2 TH23 (Gas) °C										
83	11001010	IC3 TH23 (Gas) °C										
84	00101010	IC4 TH23 (Gas) °C										
85	10101010	IC5 TH23 (Gas) °C										
86	01101010	C1 TH22 (Liquid) °C										
87	11101010	IC2 TH22 (Liquid) °C										
88	00011010	IC3 TH22 (Liquid) °C										
89	10011010	IC4 TH22 (Liquid) °C										
90	01011010	IC5 TH22 (Liquid) °C										
91	11011010	IC1 TH21 (Intake) °C	-99.9 ~ 999.9									"Display of outdoor subcool (SC) data" (When the indoor unit is not connected, it is displayed as "0".)
92	00111010	IC2 TH21 (Intake) °C										
93	10111010	IC3 TH21 (Intake) °C										
94	01111010	IC4 TH21 (Intake) °C										
95	11111010	IC5 TH21 (Intake) °C										
96	00000110	Outdoor SC (cooling) °C	-99.9 ~ 999.9									

No.	SW1 setting	Display mode	Display on the LED1, 2 (display data)								Notes	
			1	2	3	4	5	6	7	8		
97	10000110	Target subcool °C	0.0 ~ 20.0									
98	01000110	IC1 SC/SH °C	"-99.9 ~ 999.9 during heating: subcool (SC)/during cooling: superheat (SH)"								Display of indoor SC/SH data	
99	11000110	IC2 SC/SH °C										
100	00100110	IC3 SC/SH °C										
101	10100110	IC4 SC/SH °C										
102	01100110	IC5 SC/SH °C										
103	11100110	Discharge superheat (Std) °C	-99.9 ~ 999.9								Display of target subcool step data	
105	10010110	Target Pfr display /heating kg/f	Pdm (0.0 ~ 30.0)									
106	01010110	Target ET display (cooling) °C	ETm (-2.0 ~ 23.0)									
107	11010110	Target outdoor SC (cooling) °C	SCm (0.0 ~ 20.0)									
108	00110110	Target indoor SC/SH (IC1) °C										
109	10110110	Target indoor SC/SH (IC2) °C										
110	01110110	Target indoor SC/SH (IC3) °C	SCm/SHm (0.0~20.0)									
111	11110110	Target indoor SC/SH (IC4) °C										
112	00001110	Target indoor SC/SH (IC5) °C										
113	10001110	Indoor unit check status	No.9 unit check	No.10 unit check	No.11 unit check	No.12 unit check					Check: light on Normal: light off	
114	01001110	Indoor unit operation mode	No.9 unit mode	No.10 unit mode	No.11 unit mode	No.12 unit mode					"COOL/DRY: light on HEAT: light flashing FAN/STOP: light off"	
115	11001110	Indoor unit operation display	No.9 unit operation	No.10 unit operation	No.11 unit operation	No.12 unit operation					"Thermo-ON: light on Thermo-OFF: light off"	
116	00101110	IC9 operation mode	OFF	Fan	"Cooling Thermo-ON"	"Cooling thermo-OFF"	"Heating thermo-ON"	"Heating thermo-OFF"			Display of indoor unit operation mode	
117	10101110	IC10 operation mode										
118	01101110	IC11 operation mode										
119	11101110	IC12 operation mode										
120	00011110	Target indoor SC/SH (IC9) °C										
121	10011110	Target indoor SC/SH (IC10) °C										
122	01011110	Target indoor SC/SH (IC11) °C										
123	11011110	Target indoor SC/SH (IC12) °C										
124	00111110	IC9 LEV opening pulse abnormality delay	SCm/SHm (0.0 ~ 20.0)									Display of all control target data
125	10111110	IC10 LEV opening pulse abnormality delay	0 ~ 2000									Display of opening pulse of indoor LEV at time of abnormality delay
126	01111110	IC11 LEV opening pulse abnormality delay										
127	11111110	IC12 LEV opening pulse abnormality delay										
128	00000001	Actual frequency of abnormality delay	0 ~ FF (16 progressive)									Display of actual frequency at time of abnormality delay
129	10110001	Fan step number at time of abnormality delay	0 ~ 15									Display of fan step number at time of abnormality delay
131	11000001	IC1 LEV opening pulse abnormality delay										
132	00100001	IC2 LEV opening pulse abnormality delay										
133	1010000	IC3 LEV opening pulse abnormality delay	0 ~ 2000									Delay of opening pulse of indoor LEV at time of abnormality delay
134	0110000	IC4 LEV opening pulse abnormality delay										
135	11100001	IC5 LEV opening pulse abnormality delay										

No.	SW1 setting	Display mode	Display on the LED1, 2 (display data)								Notes		
			1	2	3	4	5	6	7	8			
136	00010001	High-pressure sensor data at time of abnormality delay kgf/cm ²											
137	10010001	TH4 sensor data at time of abnormality delay °C											
138	01010001	TH6 sensor data at time of abnormality delay °C											
139	11010001	TH3 sensor data at time of abnormality delay °C											
140	00110001	TH8 sensor data at time of abnormality delay °C											
141	10110001	OC SC (cooling) at time of abnormality delay °C											
142	01110001	IC1 SC/SH at time of abnormality delay °C											
143	11110001	IC2 SC/SH at time of abnormality delay °C											
144	00001001	IC3 SC/SH at time of abnormality delay °C											
145	10001001	IC4 SC/SH at time of abnormality delay °C											
146	01001001	IC5 SC/SH at time of abnormality delay °C											
147	11001001	IC8 SC/SH at time of abnormality delay °C											
148	00100001	IC10 SC/SH at time of abnormality delay °C											
149	10101001	IC11 SC/SH at time of abnormality delay °C											
150	01101001	IC12 SC/SH at time of abnormality delay °C											
151	11101001	IC9 LEV opening pulse at time of abnormality											
152	00011001	IC10 LEV opening pulse at time of abnormality											
153	10011001	IC11 LEV opening pulse at time of abnormality											
154	01011001	IC12 LEV opening pulse at time of abnormality											
155	11011001	IC9 SC/SH at time of abnormality											
156	00111001	IC10 SC/SH at time of abnormality											
157	10111001	IC11 SC/SH at time of abnormality											
158	01111001	IC12 SC/SH at time of abnormality											
159	11111001	IC9 Capacity code											
160	00000101	IC10 Capacity code											
161	10000101	IC11 Capacity code											
162	01000101	IC12 Capacity code											

No.	SW1 setting	Display mode	Display on the LED1, 2 (display data)								Notes	
			1	2	3	4	5	6	7	8		
163	12345678	IC9 SC/SH	-99.9 ~ 999.9									Display of indoor SC/SH data
164	00100101	IC10 SC/SH										
165	10100101	IC11 SC/SH										
166	01100101	IC12 SC/SH										
170	01010101	ROM version monitor										Display of version data of ROM
171	11010101	ROM type										Display of ROM type
172	00110101	Check sum mode										Display of check sum code of ROM
173	10110101	IC9 TH23 (Gas) °C										
174	01110101	IC10 TH23 (Gas) °C										
175	11110101	IC11 TH23 (Gas) °C										
176	00001101	IC12 TH23 (Gas) °C										
177	10001101	IC9 TH22 (Liquid) °C										
178	01001101	IC10 TH22 (Liquid) °C										
179	1001101	IC11 TH22 (Liquid) °C										
180	00101101	IC12 TH22 (Liquid) °C										
185	10011101	IC9 TH21 (Intake) °C										
186	01011101	IC10 TH21 (Intake) °C										
187	11011101	IC11 TH21 (Intake) °C										
188	00111101	IC12 TH21 (Intake) °C										
189	10111101	4420 Error history	-	-	ACTM error	-	-	-	CT sensor disconnection	Under voltage	Over voltage	Display if detection data from each indoor thermistor
192	00000011	Actual frequency of abnormality	0 ~ FF (16progressive)									Display of actual frequency at time of abnormality
193	10000011	Fan step number at time of abnormality	0 ~ 15									Display of fan step number at time of abnormality
195	11000011	IC1 LEV opening pulse at time of abnormality										Display of opening pulse of indoor LEV at time of abnormality
196	00100011	IC2 LEV opening pulse at time of abnormality										
197	10100011	IC3 LEV opening pulse at time of abnormality										
198	01100011	IC4 LEV opening pulse at time of abnormality										
199	11100011	IC5 LEV opening pulse at time of abnormality										
200	00010011	High-pressure sensor data at time of abnormality										Display of data from high-pressure sensor, all thermistors, and SC/SH at time of abnormality.
201	10010011	TH4 sensor data at time of abnormality										
202	01010011	TH6 sensor data at time of abnormality	-99.9 ~ 999.9									
203	11010011	TH3 sensor data at time of abnormality										
204	00110011	TH8 sensor data at time of abnormality										

No.	SW1 setting 12345678	Display mode	Display on the LED1, 2 (display data)								Notes
			1	2	3	4	5	6	7	8	
238	01110111	IC6 SC/SH at time of abnormality delay °C									Display data from high-pressure sensor, all thermistors and SC/SH at time of abnormality.
239	11110111	IC7 SC/SH at time of abnormality delay °C	_99.9 ~ 999.9								
240	00001111	IC8 SC/SH at time of abnormality delay °C									
241	10001111	IC6 LEV opening pulse at time of abnormality									Display of opening pulse of indoor LEV at time of abnormality
242	01001111	IC7 EV opening pulse at time of abnormality	0~2000								
243	11001111	IC8 LEV opening pulse at time of abnormality									
244	00101111	IC6 SC/SH at time of abnormality									Display data from high-pressure sensor, all thermistors and SC/SH at time of abnormality.
245	10101111	IC7 SC/SH at time of abnormality	_99.9 ~ 999.9								
246	01101111	IC8 SC/SH at time of abnormality									
250	01011111	IC9 LEV opening pulse									Display of opening pulse of indoor LEV
251	11011111	IC10 LEV opening pulse	0~2000								
252	00111111	IC11 LEV opening pulse									
253	10111111	IC12 LEV opening pulse									

This chapter provides an introduction to electrical wiring for the CITY MULTI-S series, together with notes concerning power wiring, wiring for control (transmission wires and remote controller wires), and the frequency converter.

9-1. OVERVIEW OF POWER WIRING

- (1) Use a separate power supply for the outdoor unit and indoor unit.
- (2) Bear in mind ambient conditions (ambient temperature, direct sunlight, rain water, etc.) when proceeding with the wiring and connections.
- (3) The wire size is the minimum value for metal conduit wiring. The power cord size should be 1 rank thicker consideration of voltage drops. Make sure the power-supply voltage does not drop more than 10 %.
- (4) Specific wiring requirements should adhere to the wiring regulations of the region.
- (5) Power supply cords of parts of appliances for outdoor use shall not be lighter than polychloroprene sheathed flexible cord (design 60245 IEC57). For example, use wiring such as YZW.
- (6) Install an earth longer than other cables.

⚠ Warning:

- Be sure to use specified wires to connect so that no external force is imparted to terminal connections. If connections are not fixed firmly, it may cause heating or fire.
- Be sure to use the appropriate type of overcurrent protection switch. Note that generated overcurrent may include some amount of direct current.

⚠ Caution:

- Some installation site may require attachment of an earth leakage breaker. If no earth leakage breaker is installed, it may cause an electric shock.
- Do not use anything other than breaker and fuse with correct capacity. Using fuse and wire or copper wire with too large capacity may cause a malfunction of unit or fire.
- Be sure to install N-Line. Without N-Line, it could cause damage to the unit.

9-2. WIRING OF MAIN POWER SUPPLY AND EQUIPMENT CAPACITY

9-2-1. Wiring diagram for main power supply

PUMY-P112VKM(-BS)

PUMY-P125VKM(-BS)

PUMY-P140VKM(-BS)

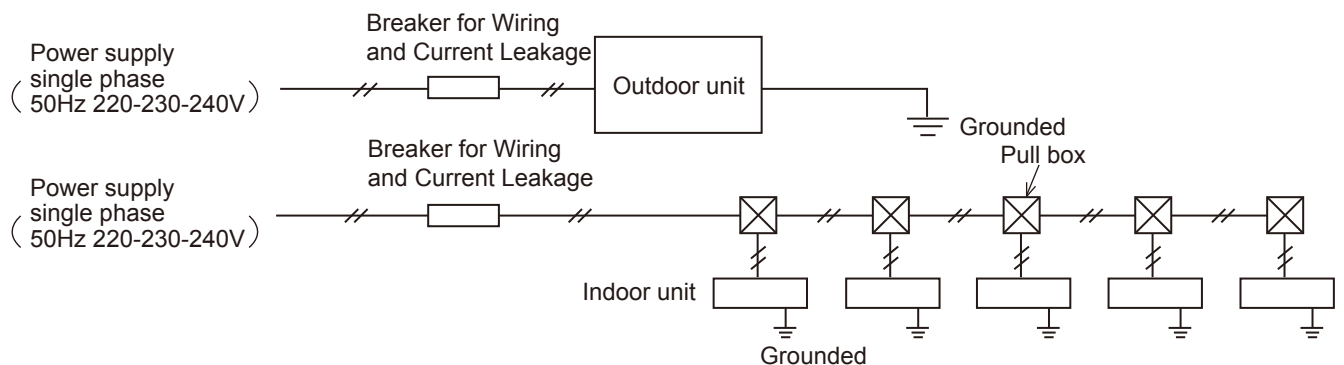

PUMY-P112YKM(-BS)

PUMY-P125YKM(-BS)

PUMY-P140YKM(-BS)

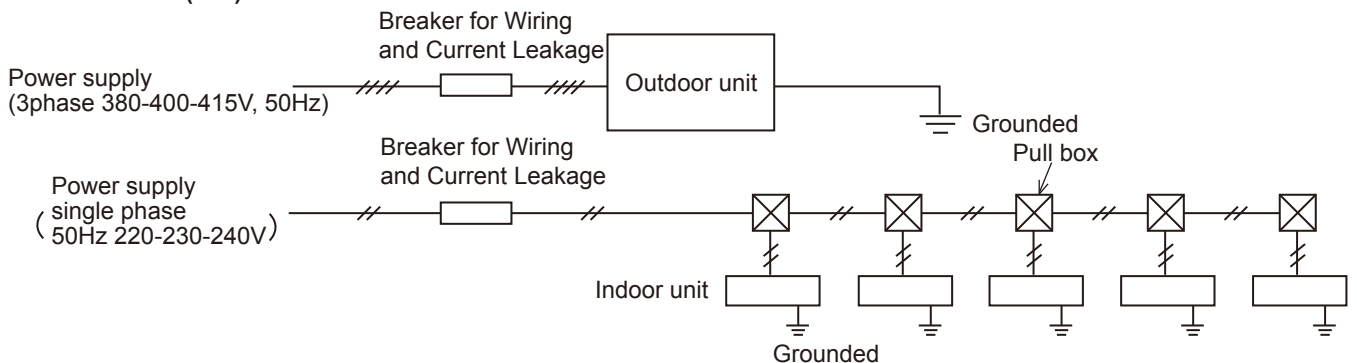

9-2-2. Cross section area of Wire for Main Power and ON/OFF capacities

PUMY-P112VKM(-BS) PUMY-P112YKM(-BS)
 PUMY-P125VKM(-BS) PUMY-P125YKM(-BS)
 PUMY-P140VKM(-BS) PUMY-P140YKM(-BS)

Model		Power Supply	Minimum Wire Cross-sectional area (mm ²)			Breaker for Wiring*	Breaker for Current Leakage
			Main Cable	Branch	Ground		
Outdoor Unit	P112-140V	~N 220/230/240 V 50 Hz	5.5(6)	—	5.5(6)	32 A	32 A 30 mA 0.1 sec. or less
	P112-140Y	3N~380/400/415 V 50 Hz	1.5	—	1.5	16 A	16 A 30 mA 0.1 sec. or less

*A breaker with at least 3.0 mm contact separation in each poles shall be provided. Use non-fuse breaker (NF) or earth leakage breaker (NV).

Total operating current of the indoor unit	Minimum wire thickness (mm ²)			Ground-fault interrupter*	Local switch (A)		Breaker for wiring (NFB)
	Main Cable	Branch	Ground		Capacity	Fuse	
F0 = 16A or less**	1.5	1.5	1.5	20 A current sensitivity***	16	16	20
F0 = 25A or less**	2.5	2.5	2.5	30 A current sensitivity***	25	25	30
F0 = 32A or less**	4.0	4.0	4.0	40 A current sensitivity***	32	32	40

Apply to IEC61000-3-3 about max. permissive system impedance.

*The Ground-fault interrupter should support inverter circuit.
 The Ground-fault interrupter should combine using of local switch or wiring breaker.

**Please take the larger of F1 or F2 as the value for F0.
 F1 = Total operating maximum current of the indoor units × 1.2
 F2 = {V1 × (Quantity of Type1)/C} + {V1 × (Quantity of Type2)/C} + {V1 × (Quantity of Type3)/C} + {V1 × (Quantity of Others)/C}

Indoor unit		V1	V2
Type 1	PLFY-VBM, PMFY-VBM, PEFY-VMS, PCFY-VKM, PKFY-VHM, PKFY-VKM	18.6	2.4
Type 2	PEFY-VMA	38	1.6
Type 3	PEFY-VMHS	13.8	4.8
Others	Other indoor unit	0	0

C : Multiple of tripping current at tripping time 0.01s
 Please pick up "C" from the tripping characteristic of the breaker.

<Example of "F2" calculation>
 * Condition PEFY-VMS × 4 + PEFY-VMA × 1, C = 8 (refer to right sample chart)
 F2 = 18.6 × 4/8 + 38 × 1/8
 = 14.05
 → 16A breaker (Tripping current = 8 × 16A at 0.01s)

***Current sensitivity is calculated using the following formula.
 G1 = V2 × (Quantity of Type1) + V2 × (Quantity of Type2) + V2 × (Quantity of Type3) + V2 × (Quantity of Others) + V3 × (Wire length[km])

G1	Current sensitivity
30 or less	30 mA 0.1sec or less
100 or less	100 mA 0.1sec or less

Wire thickness	V3
1.5 mm ²	48
2.5 mm ²	56
4.0 mm ²	66

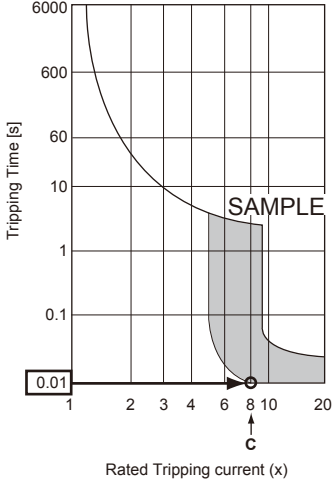

9-3. DESIGN FOR CONTROL WIRING

Please note that the types and numbers of control wires needed by the CITY MULTI-S series will depend on the remote controllers and whether they are linked with the system.

9-3-1. Selection number of control wires

		M-NET remote controller
Use		Remote controller used in system control operations. • Group operation involving different refrigerant systems. • Linked operation with upper control system.
Remote controller → indoor unit		2 wires (non-polar)
Transmission wires	Wires connecting → indoor units	
	Wires connecting → indoor units with outdoor unit	
	Wires connecting → outdoor units	

9-4. WIRING TRANSMISSION CABLES

9-4-1. Types of control cables

1. Wiring transmission cables
 - Types of transmission cables: Shielding wire CVVS or CPEVS or MVVS
 - Cable diameter: More than 1.25 mm²
 - Maximum wiring length: Within 200 m

2. M-NET Remote control cables

Kind of remote control cable	Shielding wire MVVS
Cable diameter	0.5 to 1.25 mm ²
Remarks	When 10 m is exceeded, use a cable with the same specifications as transmission line wiring.

3. MA Remote control cables

Kind of remote control cable	Sheathed 2-core cable (unshielded) CVV
Cable diameter	0.3 to 1.25 mm ² (0.75 to 1.25 mm ²)*
Remarks	Within 200 m

* Connected with simple remote controller.

9-4-2. Wiring examples

- Controller name, symbol and allowable number of controllers.

Name	Symbol	Allowable number of controllers	
Outdoor unit controller	OC	-	
Indoor unit controller	IC	PUMY-P112	1 to 9 units per 1 OC
		PUMY-P125	1 to 10 units per 1 OC
		PUMY-P140	1 to 12 units per 1 OC
Remote controller	RC	RC (M-NET)	Maximum of 12 controllers for 1 OC
		MA	Maximum of 2 per group

9-5. SYSTEM SWITCH SETTING

In order to identify the destinations of signals to the outdoor units, indoor units, and remote controller of the MULTI-S series, each microprocessor must be assigned an identification number (address). The addresses of outdoor units, indoor units, and remote controller must be set using their settings switches. Please consult the installation manual that comes with each unit for detailed information on setting procedures.

9-6. EXAMPLE EXTERNAL WIRING DIAGRAM FOR A BASIC SYSTEM

Example using a M-NET remote controller

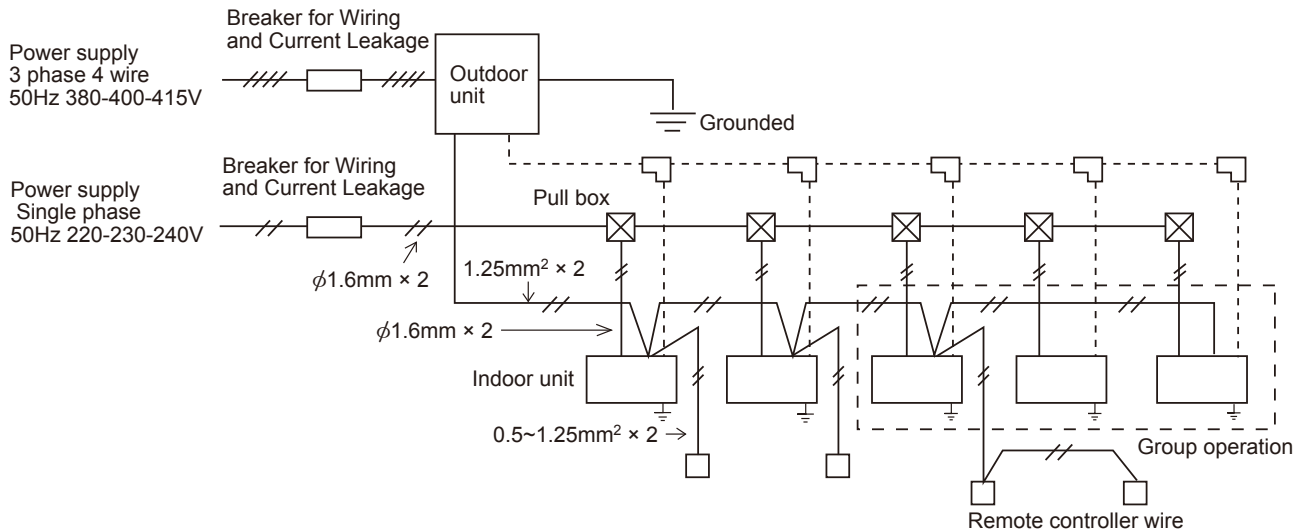

9-7. METHOD FOR OBTAINING ELECTRICAL CHARACTERISTICS WHEN A CAPACITY AGREEMENT IS TO BE SIGNED WITH AN ELECTRIC POWER COMPANY

The electrical characteristics of connected indoor unit system for air conditioning systems, including the MULTI-S series, will depend on the arrangement of the indoor and outdoor units.

First read the data on the selected indoor and outdoor units and then use the following formulas to calculate the electrical characteristics before applying for a capacity agreement with the local electric power company.

9-7-1. Obtaining the electrical characteristics of a CITY MULTI-S series system

(1) Procedure for obtaining total power consumption

	Page numbers in this technical manual	Power consumption
Total power consumption of each indoor unit	See the technical manual of each indoor unit	①
Power consumption of outdoor unit*	Standard capacity table— Refer to 4-3.	②
Total power consumption of system	See the technical manual of each indoor unit	①+② <kW>

*The power consumption of the outdoor unit will vary depending on the total capacity of the selected indoor units.

(2) Method of obtaining total current

	Page numbers in this technical manual	Subtotal
Total current through each indoor unit	See the technical manual of each indoor unit	①
Current through outdoor unit*	Standard capacity table— Refer to 4-3.	②
Total current through system	See the technical manual of each indoor unit	①+② <A>

The current through the outdoor unit will vary depending on the total capacity of the selected indoor units.

(3) Method of obtaining system power factor

Use the following formula and the total power and current obtained in parts ① and ② on the above tables to calculate the system power factor.

$$\text{System power factor} = \frac{(\text{Total system power consumption})}{(\text{Total system current} \times \text{voltage})} \times 100 \%$$

9-7-2. Applying to an electric power company for power and total current

Calculations should be performed separately for heating and cooling employing the same methods; use the largest resulting value in your application to the electric power company.

10-1. REFRIGERANT PIPING SYSTEM

Line-Branch Method
 Connection Examples
 (Connecting to 4 Indoor Units)

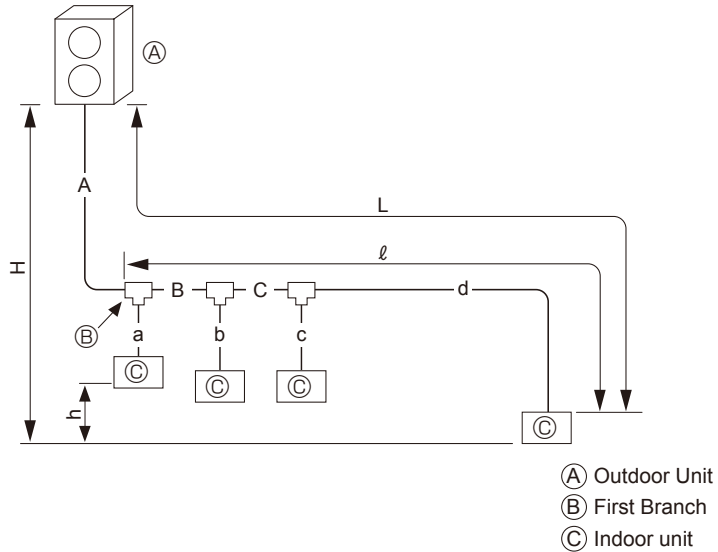

Permissible Length	Total Piping Length	$A+B+C+a+b+c+d \leq 300 \text{ m}$
	Farthest Piping Length (L)	$A+B+C+d \leq 150 \text{ m}$
	Farthest Piping Length After First Branch (l)	$B+C+d \leq 30 \text{ m}$
Permissible High/Low Difference	High/Low Difference in Indoor/Outdoor Section (H)	50 meters or less (If the outdoor unit is lower, 40 meters or less)
	High/Low Difference in Indoor/Indoor Section (h)	15 meters or less

■ **Selecting the Refrigerant Branch Kit**

Use an optional branch piping kit (CMY-Y62-G-E).

■ **Select Each Section of Refrigerant Piping**

- (1) Section From Outdoor Unit to First Branch (A)
 - (2) Sections From Branch to Indoor Unit (a,b,c,d)
 - (3) Section From Branch to Branch (B,C)
- } Each Section of Piping

Select the size from the table to the right.

(1) Refrigerant Piping Diameter In Section From Outdoor Unit to First Branch (Outdoor Unit Piping Diameter)

Model	Piping Diameter (mm)	
PUMY-P112	Liquid Line	φ9.52
PUMY-P125	Gas Line	φ15.88
PUMY-P140		

(2) Refrigerant Piping Diameter In Section From Branch to Indoor Unit (Indoor Unit Piping Diameter)

Model number	Piping Diameter (mm)	
50 or lower	Liquid Line	φ6.35
	Gas Line	φ12.7
63 to 140	Liquid Line	φ9.52
	Gas Line	φ15.88

Note:
 When connecting the CONNECTION KIT (PAC-LV11M-J) and an M-series indoor unit, refer to the installation manual for the CONNECTION KIT when selecting the pipe size and piping length.

(3) Refrigerant Piping Diameter In Section From Branch to Branch

Liquid Line (mm)	Gas Line (mm)
φ9.52	φ15.88

■ **Additional refrigerant charge**

Refrigerant for the extended piping is not included in the outdoor unit when the unit is shipped from the factory. Therefore, charge each refrigerant piping system with additional refrigerant at the installation site. In addition, in order to carry out service, enter the size and length of each liquid pipe and additional refrigerant charge amounts in the spaces provided on the "Refrigerant amount" plate on the outdoor unit.

Calculation of additional refrigerant charge

- Calculate the additional charge using the liquid pipe size and length of the extended piping and total capacity of connected indoor units.
- Calculate the additional refrigerant charge using the procedure shown to the right, and charge with the additional refrigerant.
- For amounts less than 0.1 kg, round up the calculated additional refrigerant charge.
 (For example, if the calculated charge is 6.01 kg, round up the charge to 6.1 kg.)

<Additional Charge>

Calculation of refrigerant charge

Pipe size Liquid pipe ø6.35 (m) × 19.0 (g/m)	+	Pipe size Liquid pipe ø9.52 (m) × 50.0 (g/m)	+	Total capacity of connected indoor units ~ 8.0 kW 8.1 ~ 16.0 kW 16.1 kW ~	Amount for the indoor units 1.5 kg 2.5 kg 3.0 kg
--	---	--	---	--	---

Included refrigerant amount when shipped from the factory

Included refrigerant amount

<Example>

Outdoor model : P125

Indoor 1 : P63 (7.1 kW) A : ø9.52 30 m a : ø9.52 15 m
 2 : P40 (4.5 kW) b : ø6.35 10 m
 3 : P25 (2.8 kW) c : ø6.35 10 m
 4 : P20 (2.2 kW) d : ø6.35 20 m

} At the conditions below:

The total length of each liquid line is as follows:

ø9.52 : A + a = 30 + 15 = 45 m

ø6.35 : b + c + d = 10 + 10 + 20 = 40 m

The total capacity of connected indoor unit is as follows:

7.1 + 4.5 + 2.8 + 2.2 = 16.6

<Calculation example>

Additional refrigerant charge

$$40 \times \frac{19.0}{1000} + 45 \times \frac{50.0}{1000} + 3.0 = 6.1 \text{ kg (rounded up)}$$

Header-Branch Method
Connection Examples
(Connecting to 4 Indoor Units)

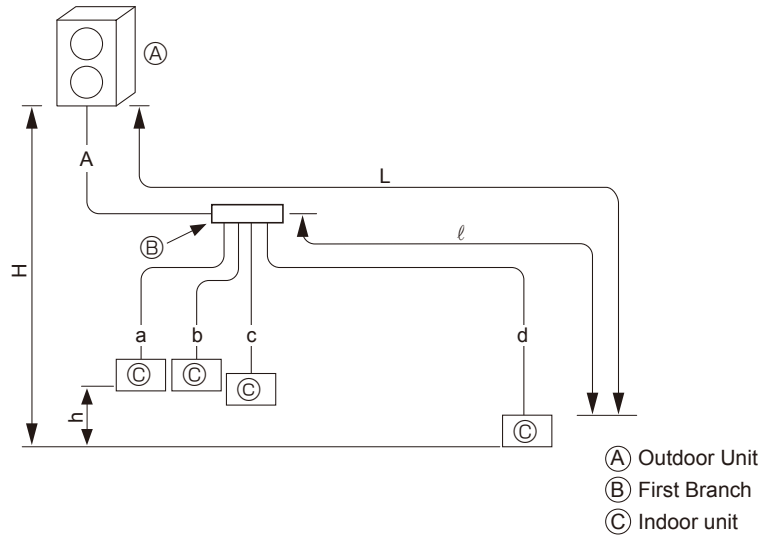

Permissible Length	Total Piping Length	$A+a+b+c+d \leq 300$ m
	Farthest Piping Length (L)	$A+d \leq 150$ m
	Farthest Piping Length After First Branch (ℓ)	d is 30 meters or less
Permissible High/Low Difference	High/Low Difference in Indoor/Outdoor Section (H)	50 meters or less (If the outdoor unit is lower, 40 meters or less)
	High/Low Difference in Indoor/Indoor Section (h)	15 meters or less

■ **Selecting the Refrigerant Branch Kit**

Please select branching kit, which is sold separately, from the table below.
(The kit comprises sets for use with liquid pipes and for use with gas pipes.)

Branch header (4 branches)	Branch header (8 branches)
CMY-Y64-G-E	CMY-Y68-G-E

■ **Select Each Section of Refrigerant Piping**

- (1) Section From Outdoor Unit to First Branch (A)
(2) Sections From Branch to Indoor Unit (a,b,c,d)
- Each Section of Piping

Select the size from the table to the right.

(1) Refrigerant Piping Diameter In Section From Outdoor Unit to First Branch (Outdoor Unit Piping Diameter)

Model	Piping Diameter (mm)	
PUMY-P112	Liquid Line	$\phi 9.52$
PUMY-P125	Gas Line	$\phi 15.88$
PUMY-P140		

(2) Refrigerant Piping Diameter In Section From Branch to Indoor Unit (Indoor Unit Piping Diameter)

Model number	Piping Diameter (mm)	
50 or lower	Liquid Line	$\phi 6.35$
	Gas Line	$\phi 12.7$
63 to 140	Liquid Line	$\phi 9.52$
	Gas Line	$\phi 15.88$

Note:

When connecting the CONNECTION KIT (PAC-LV11M-J) and an M-series indoor unit, refer to the installation manual for the CONNECTION KIT when selecting the pipe size and piping length.

■ **Additional refrigerant charge**

Refrigerant for the extended piping is not included in the outdoor unit when the unit is shipped from the factory. Therefore, charge each refrigerant piping system with additional refrigerant at the installation site. In addition, in order to carry out service, enter the size and length of each liquid pipe and additional refrigerant charge amounts in the spaces provided on the "Refrigerant amount" plate on the outdoor unit.

Calculation of additional refrigerant charge

- Calculate the additional charge using the liquid pipe size and length of the extended piping and total capacity of connected indoor units.
- Calculate the additional refrigerant charge using the procedure shown to the right, and charge with the additional refrigerant.
- For amounts less than 0.1 kg, round up the calculated additional refrigerant charge.
(For example, if the calculated charge is 6.01 kg, round up the charge to 6.1 kg.)

<Additional Charge>

Calculation of refrigerant charge

Pipe size Liquid pipe $\phi 6.35$ (m) $\times 19.0$ (g/m)	+	Pipe size Liquid pipe $\phi 9.52$ (m) $\times 50.0$ (g/m)	+	Total capacity of connected indoor units ~ 8.0 kW 8.1 ~ 16.0 kW 16.1 kW ~	Amount for the indoor units 1.5 kg 2.5 kg 3.0 kg
--	---	--	---	--	---

Included refrigerant amount when shipped from the factory

Included refrigerant amount

<Example>

Outdoor model : P125

Indoor 1 : P63 (7.1 kW) A : $\phi 9.52$ 30 m a : $\phi 9.52$ 15 m
 2 : P40 (4.5 kW) b : $\phi 6.35$ 10 m
 3 : P25 (2.8 kW) c : $\phi 6.35$ 10 m
 4 : P20 (2.2 kW) d : $\phi 6.35$ 20 m

At the conditions below:

The total length of each liquid line is as follows:

$\phi 9.52$: $A + a = 30 + 15 = 45$ m

$\phi 6.35$: $b + c + d = 10 + 10 + 20 = 40$ m

The total capacity of connected indoor unit is as follows:

$7.1 + 4.5 + 2.8 + 2.2 = 16.6$

<Calculation example>

Additional refrigerant charge

$$40 \times \frac{19.0}{1000} + 45 \times \frac{50.0}{1000} + 3.0 = 6.1 \text{ kg (rounded up)}$$

Method of Combined Branching of Lines and Headers

Connection Examples
(Connecting to 5 Indoor Units)

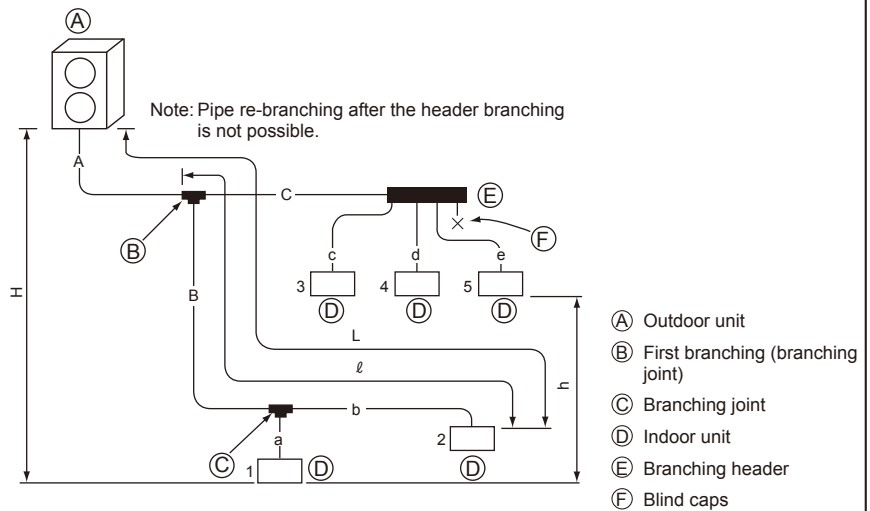

Permissible Length	Total Piping Length	A+B+C+a+b+c+d+e is 300 meters or less
	Farthest Piping Length (L)	A+B+b is 150 meters or less
	Farthest Piping Length After First Branch (ℓ)	B+b is 30 meters or less
Permissible High/Low Difference	High/Low Difference in Indoor/Outdoor Section (H)	50 meters or less (If the outdoor unit is lower, 40 meters or less)
	High/Low Difference in Indoor/Indoor Section (h)	15 meters or less

■ Selecting the Refrigerant Branch Kit

Please select branching kit, which is sold separately, from the table below.
(The kit comprises sets for use with liquid pipes and for use with gas pipes.)

Branch Joint	Branch Header (4 branches)	Branch Header (8 branches)
CMY-Y62-G-E	CMY-Y64-G-E	CMY-Y68-G-E

■ Select Each Section of Refrigerant Piping

- (1) Section From Outdoor Unit to First Branch (A)
 - (2) Sections From Branch to Indoor Unit (a,b,c,d,e)
 - (3) Section From Branch to Branch (B,C)
- } Each Section of Piping

Select the size from the table to the right.

(1) Refrigerant Piping Diameter In Section From Outdoor Unit to First Branch (Outdoor Unit Piping Diameter)

Model	Piping Diameter (mm)
PUMY-P112	Liquid Line φ9.52
PUMY-P125	Gas Line φ15.88
PUMY-P140	

(2) Refrigerant Piping Diameter In Section From Branch to Indoor Unit (Indoor Unit Piping Diameter)

Model number	Piping Diameter (mm)	
50 or lower	Liquid Line	φ6.35
	Gas Line	φ12.7
63 to 140	Liquid Line	φ9.52
	Gas Line	φ15.88

(3) Refrigerant Piping Diameter In Section From Branch to Branch

Liquid Line (mm)	Gas Line (mm)
φ9.52	φ15.88

Note:
When connecting the CONNECTION KIT (PAC-LV11M-J) and an M-series indoor unit, refer to the installation manual for the CONNECTION KIT when selecting the pipe size and piping length.

■ Additional refrigerant charge

Refrigerant for the extended piping is not included in the outdoor unit when the unit is shipped from the factory. Therefore, charge each refrigerant piping system with additional refrigerant at the installation site. In addition, in order to carry out service, enter the size and length of each liquid pipe and additional refrigerant charge amounts in the spaces provided on the "Refrigerant amount" plate on the outdoor unit.

Calculation of additional refrigerant charge

- Calculate the additional charge using the liquid pipe size and length of the extended piping and total capacity of connected indoor units.
- Calculate the additional refrigerant charge using the procedure shown to the right, and charge with the additional refrigerant.
- For amounts less than 0.1 kg, round up the calculated additional refrigerant charge.
(For example, if the calculated charge is 6.01 kg, round up the charge to 6.1 kg.)

<Additional Charge>

Calculation of refrigerant charge

Pipe size Liquid pipe φ6.35 (m) × 19.0 (g/m)	+	Pipe size Liquid pipe φ9.52 (m) × 50.0 (g/m)	+	Total capacity of connected indoor units ~ 8.0 kW 8.1 ~ 16.0 kW 16.1 kW ~	Amount for the indoor units 1.5 kg 2.5 kg 3.0 kg
---	---	---	---	---	--

Included refrigerant amount when shipped from the factory

Included refrigerant amount

<Example>

Outdoor model : P140

Indoor 1 : P63 (7.1 kW) A : φ9.52 30 m a : φ9.52 15 m
 2 : P40 (4.5 kW) B : φ9.52 10 m b : φ6.35 10 m
 3 : P25 (2.8 kW) C : φ9.52 10 m c : φ6.35 10 m
 4 : P20 (2.2 kW) d : φ6.35 20 m
 5 : P20 (2.2 kW) e : φ6.35 10 m

At the conditions below:

The total length of each liquid line is as follows:

φ9.52 : A + B + C + a = 65 m

φ6.35 : b + c + d + e = 50 m

The total capacity of connected indoor unit is as follows:

7.1 + 4.5 + 2.8 + 2.2 + 2.2 = 18.8

<Calculation example>

Additional refrigerant charge

$50 \times \frac{19.0}{1000} + 65 \times \frac{50.0}{1000} + 3.0 = 7.2 \text{ kg (rounded up)}$

10-2. PRECAUTIONS AGAINST REFRIGERANT LEAKAGE

10-2-1. Introduction

R410A refrigerant of this air conditioner is non-toxic and non-flammable but leaking of large amount from an indoor unit into the room where the unit is installed may be deleterious. To prevent possible injury, the rooms should be large enough to keep the R410A concentration specified by KHK: (a high pressure gas safety association) installation guidelines S0010 as follows.

Maximum concentration
Maximum refrigerant concentration of R410A of a room is 0.3 kg/m³ accordance with the installation guidelines. To facilitate calculation, the maximum concentration is expressed in units of kg/m³ (kg of R410A per m³)

Maximum concentration of R410A: 0.3kg/m³
(KHK installation guidelines S0010)

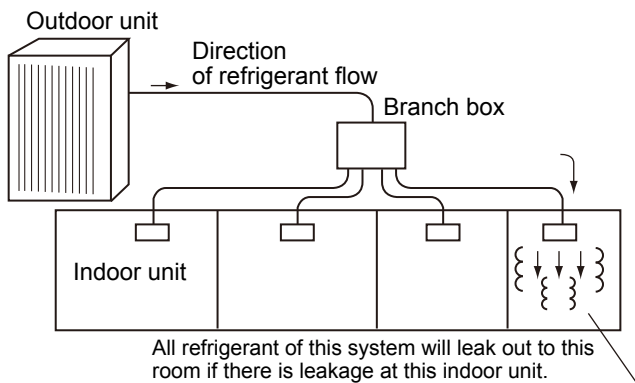

(2) Calculate room volumes (m³) and find the room with the smallest volume

The part with represents the room with the smallest volume.

(a) Situation in which there are no partitions

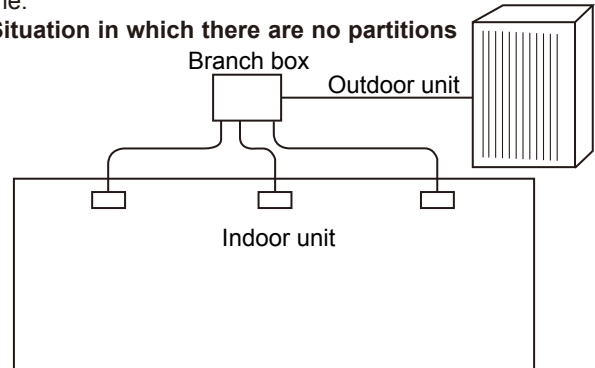

(b) There are partitions, but there are openings that allow the effective mixing of air.

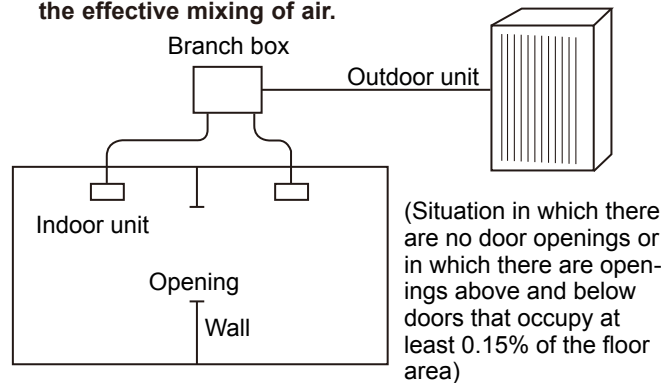

(c) If the smallest room has mechanical ventilation apparatus that is linked to a household gas detection and alarm device, the calculations should be performed for the second smallest room.

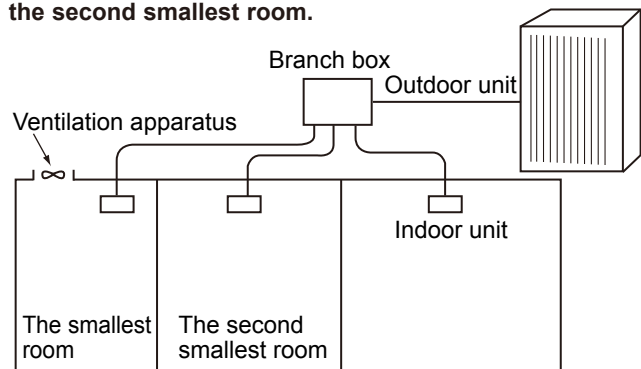

(3) Use the results of calculations (1) and (2) to calculate the refrigerant concentration:

$$\frac{\text{Total refrigerant in the refrigerating unit (kg)}}{\text{The smallest room in which an indoor unit has been installed (m}^3\text{)}} \leq \text{Maximum concentration (kg/m}^3\text{)}$$

Maximum concentration of R410A: 0.3kg/m³

If the calculation results do not exceed the maximum concentration, perform the same calculations for the larger second and third room, etc., until it has been determined that nowhere the maximum concentration will be exceeded.

10-2-2. Confirming procedure of R410A concentration

Follow (1) to (3) to confirm the R410A concentration and take appropriate treatment, if necessary.

(1) Calculate total refrigerant amount by each refrigerant system.

Total refrigerant amount is precharged refrigerant at ex-factory plus additional charged amount at field installation.



Note:
When single refrigeration system consists of several independent refrigeration circuit, figure out the total refrigerant amount by each independent refrigerant circuit.

PUMY-P112VKM(-BS)
 PUMY-P125VKM(-BS)
 PUMY-P140VKM(-BS)

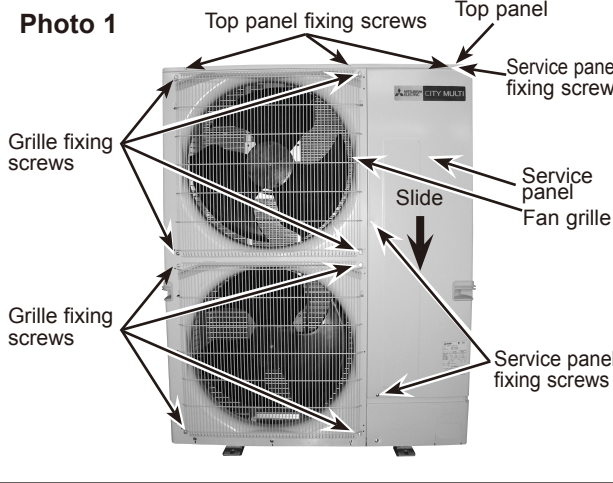
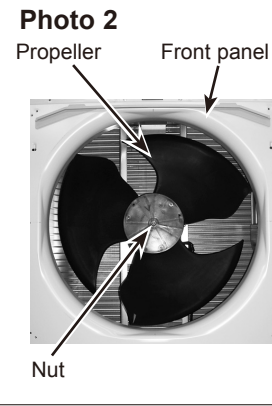
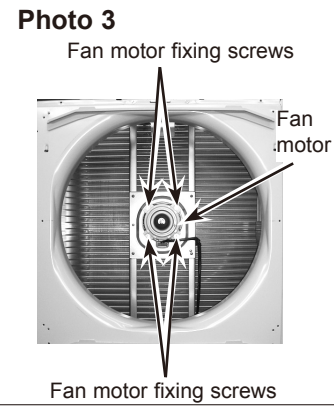
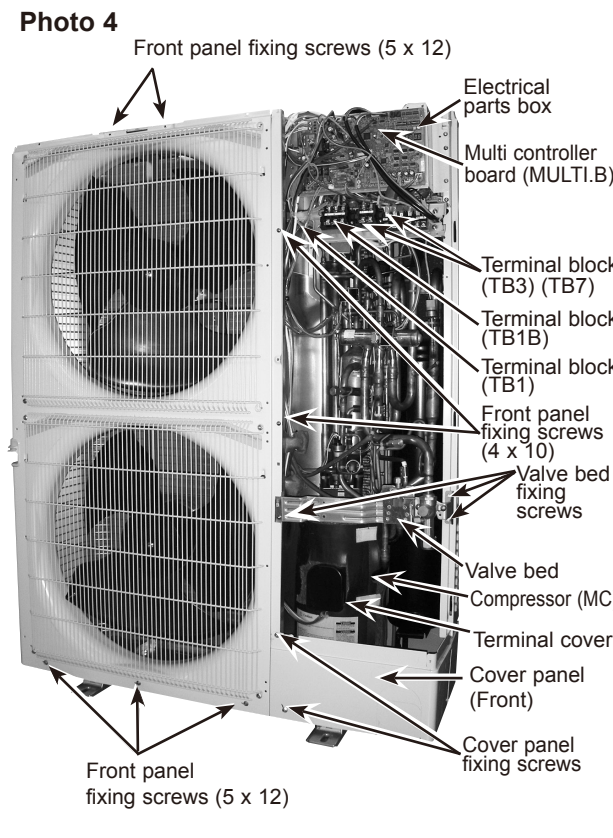
Note: Turn OFF the power supply before disassembly.

OPERATING PROCEDURE	PHOTOS & ILLUSTRATION
<p>1. Removing the service panel and top panel</p> <p>(1) Remove 3 service panel fixing screws (5 × 12) and slide the hook on the right downward to remove the service panel.</p> <p>(2) Remove screws (3 for front, 3 for rear/5 × 12) of the top panel and remove it.</p>	<p>Photo 1</p> 
<p>2. Removing the fan motor (MF1, MF2)</p> <p>(1) Remove the service panel. (See Photo 1)</p> <p>(2) Remove the top panel. (See Photo 1)</p> <p>(3) Remove 4 fan grille fixing screws (5 × 12) to detach the fan grille. (See photo 1)</p> <p>(4) Remove a nut (for right handed screw of M6) to detach the propeller. (See Photo 2)</p> <p>(5) Disconnect the connectors, CNF1 and CNF2 on multi controller board in electrical parts box.</p> <p>(6) Remove 4 fan motor fixing screws (5 × 20) to detach the fan motor. (See Photo 3)</p>	<p>Photo 2</p>  <p>Photo 3</p> 
<p>3. Removing the electrical parts box</p> <p>(1) Remove the service panel. (See Photo 1)</p> <p>(2) Remove the top panel. (See Photo 1)</p> <p>(3) Disconnect the connecting wire from terminal block.</p> <p>(4) Remove all the following connectors from multi controller board; <Diagram symbol in the connector housing></p> <ul style="list-style-type: none"> • Fan motor (CNF1, CNF2) • Thermistor <HIC pipe> (TH2) • Thermistor <Outdoor liquid pipe> (TH3) • Thermistor <Compressor> (TH4) • Thermistor <Suction pipe/Ambient, Outdoor> (TH6/7) • High pressure switch (63H) • High pressure sensor (63HS) • Low pressure sensor (63LS) • 4-way valve (21S4) • Bypass valve (SV1) <p>Pull out the disconnected wire from the electrical parts box.</p> <p>(5) Remove the terminal cover and disconnect the compressor lead wire.</p>	<p>Photo 4</p> 

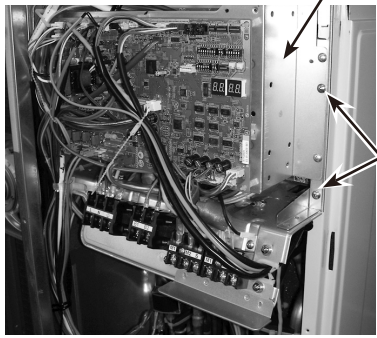
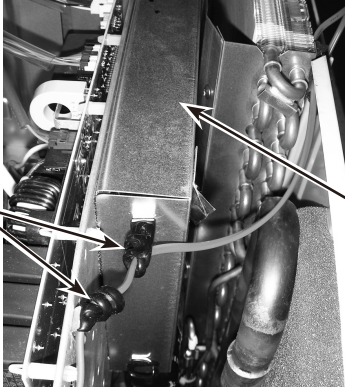
From the previous page.

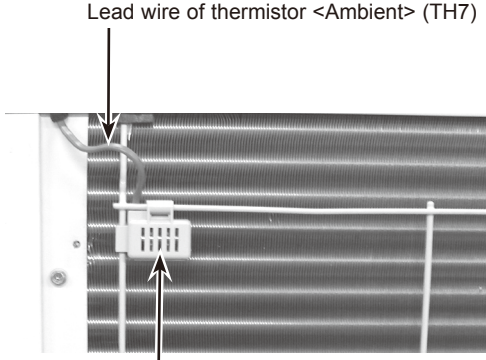
OPERATING PROCEDURE	PHOTOS & ILLUSTRATION
<p>(6) Remove 2 electrical parts box fixing screws (4 × 10) and detach the electrical parts box by pulling it upward. The electrical parts box is fixed with 2 hooks on the left and 1 hook on the right.</p>	<p>Photo 5</p>  <p>Electrical parts box</p> <p>Electrical parts box fixing screws</p>
<p>4. Removing the thermistor <Suction pipe> (TH6)</p> <ol style="list-style-type: none"> (1) Remove the service panel. (See Photo 1) (2) Remove the top panel. (See Photo 1) (3) Disconnect the connectors, TH6 and TH7 (red), on the multi controller board in the electrical parts box. (4) Loosen the wire clamps on the side of the electrical parts box, and next to it. (5) Pull out the thermistor <Suction pipe> (TH6) from the sensor holder. <p>Note: When replacing thermistor <Suction pipe> (TH6), replace it together with thermistor <Ambient> (TH7) since they are combined together. Refer to procedure No.5 below to remove thermistor <Ambient> (TH7).</p>	<p>Photo 6</p>  <p>Clamps</p> <p>Electrical parts box</p> <p>Photo 7</p>  <p>High pressure sensor (63HS)</p> <p>Thermistor <Suction pipe> (TH6)</p> <p>Thermistor <HIC pipe> (TH2)</p> <p>Ball valve and stop valve fixing screws</p> <p>Thermistor <Compressor> (TH4)</p>
<p>5. Removing the thermistor <Ambient> (TH7)</p> <ol style="list-style-type: none"> (1) Remove the service panel. (See Photo 1) (2) Remove the top panel. (See Photo 1) (3) Disconnect the connector TH7 (red) on the Multi controller board in the electrical parts box. (4) Loosen the wire clamps on top of the electrical parts box. (See Photo 6) (5) Pull out the thermistor <Ambient> (TH7) from the sensor holder. <p>Note: When replacing thermistor <Ambient> (TH7), replace it together with thermistor <Suction pipe> (TH6), since they are combined together. Refer to procedure No.4 above to remove thermistor <Suction pipe> (TH6).</p>	<p>Photo 8</p>  <p>Lead wire of thermistor <Ambient> (TH7)</p> <p>Sensor holder</p>

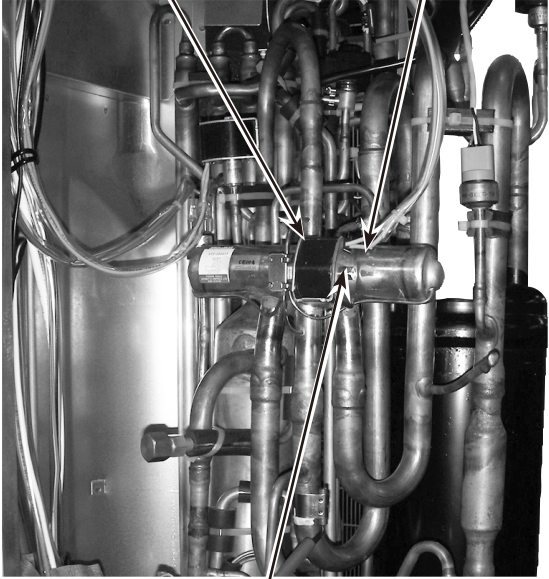

OPERATING PROCEDURE	PHOTOS
<p>6. Removing the thermistor <Outdoor liquid pipe> (TH3) and thermistor <Compressor> (TH4), thermistor <HIC pipe> (TH2)</p> <ol style="list-style-type: none">(1) Remove the service panel. (See Photo 1)(2) Disconnect the connectors, TH3 (white) and TH4 (white), TH2 (black) on the multi controller board in the electrical parts box.(3) Loosen the clamp for the lead wire in the rear of the electrical parts box.(4) Pull out the thermistor <Outdoor liquid pipe> (TH3) and thermistor <Compressor> (TH4) from the sensor holder. (See Photo 7 and 9)	<p>Photo 9</p>  <p>Thermistor <Outdoor liquid pipe> (TH3)</p>
<p>7. Removing the 4-way valve coil (21S4)</p> <ol style="list-style-type: none">(1) Remove the service panel. (See Photo 1) <p>[Removing the 4-way valve coil]</p> <ol style="list-style-type: none">(2) Remove 4-way valve coil fixing screw (M5 × 7).(3) Remove the 4-way valve coil by sliding the coil toward you.(4) Disconnect the connector 21S4 (green) on the multi controller board in the electrical parts box.	<p>Photo 10</p>  <p>4-way valve coil (21S4) 4-way valve</p> <p>4-way valve coil fixing screw</p>
<p>8. Removing the 4-way valve</p> <ol style="list-style-type: none">(1) Remove the service panel. (See Photo 1)(2) Remove the top panel. (See Photo 1)(3) Remove the electrical parts box (See photo 5)(4) Remove 3 valve bed fixing screws (4 × 10) and 4 ball valve and stop valve fixing screws (5 × 16) and then remove the valve bed. (See Photo 4 and 7)(5) Remove 4 right side panel fixing screw (5 × 12) in the rear of the unit and then remove the right side panel.(6) Remove the 4-way valve coil. (See Photo 10)(7) Recover refrigerant.(8) Remove the welded part of four-way valve. <p>Note 1: Recover refrigerant without spreading it in the air.</p> <p>Note 2: The welded part can be removed easily by removing the right side panel.</p> <p>Note 3: When installing the four-way valve, cover it with a wet cloth to prevent it from heating (120°C or more), then braze the pipes so that the inside of pipes are not oxidized.</p>	

OPERATING PROCEDURE

9. Removing bypass valve coil (SV1) and bypass valve

- (1) Remove the service panel. (See Photo 1)
- (2) Remove the top panel. (See Photo 1)
- (3) Remove 3 right side panel fixing screws (5 × 12) in the rear of the unit and remove the right side panel.
- (4) Remove the bypass valve coil fixing screw (M4 × 6).
- (5) Remove the bypass valve coil by sliding the coil upward.
- (6) Disconnect the connector SV1 (gray) on the multi controller circuit board in the electrical parts box.
- (7) Remove the electrical parts box. (See photo 5)
- (8) Recover refrigerant.
- (9) Remove the welded part of bypass valve.

Note 1: Recover refrigerant without spreading it in the air.

Note 2: The welded part can be removed easily by removing the right side panel.

Note3: When installing the four-way valve, cover it with a wet cloth to prevent it from heating (120°C or more), then braze the pipes so that the inside of pipes are not oxidized.

10. Removing the high pressure switch (63H) and high pressure sensor (63HS)

- (1) Remove the service panel. (See Photo 1)
- (2) Remove the top panel. (See Photo 1)
- (3) Remove 3 right side panel fixing screws (5 × 12) in the rear of the unit and remove the right side panel.
- (4) Pull out the lead wire of high pressure switch and high pressure sensor.
- (5) Remove the electrical parts box. (See Photo 5)
- (6) Recover refrigerant.
- (7) Remove the welded part of high pressure switch and high pressure sensor.

Note 1: Recover refrigerant without spreading it in the air.

Note 2: The welded part can be removed easily by removing the right side panel.

Note 3: When installing the high pressure switch and high pressure sensor, cover them with a wet cloth to prevent them from heating (100°C or more), then braze the pipes so that the inside of pipes are not oxidized.

11. Removing the low pressure sensor (63LS)

- (1) Remove the service panel. (See Photo 1)
- (2) Remove the top panel. (See Photo 1)
- (3) Remove 3 right side panel fixing screws (5 × 12) in the rear of the unit and remove the right side panel.
- (4) Disconnect the connector 63LS (blue) on the multi controller circuit board in the electrical parts box.
- (5) Remove the electrical parts box. (See Photo 5)
- (6) Recover refrigerant.
- (7) Remove the welded part of low pressure sensor.

Note 1: Recover refrigerant without spreading it in the air.

Note 2: The welded part can be removed easily by removing the right side panel.

Note 3: When installing the low pressure sensor, cover it with a wet cloth to prevent it from heating (100°C or more), then braze the pipes so that the inside of pipes are not oxidized.

12. Removing electronic expansion valve (LEV-A, LEV-B)

- (1) Remove the service panel. (See Photo 1)
- (2) Remove the top panel. (See Photo 1)
- (3) Remove 3 right side panel fixing screws (5 × 12) in the rear of the unit and remove the right side panel.
- (4) Remove the electrical expansion valve coil. (See Photo 11,12)
- (5) Remove the electrical parts box. (See Photo 5)
- (6) Recover refrigerant.
- (7) Remove the welded part of electrical expansion valve.

PHOTOS

Photo 11

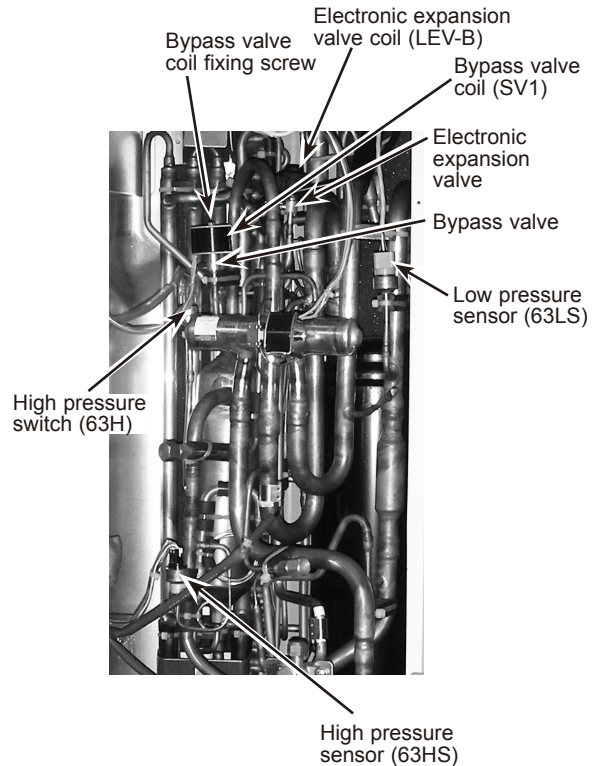
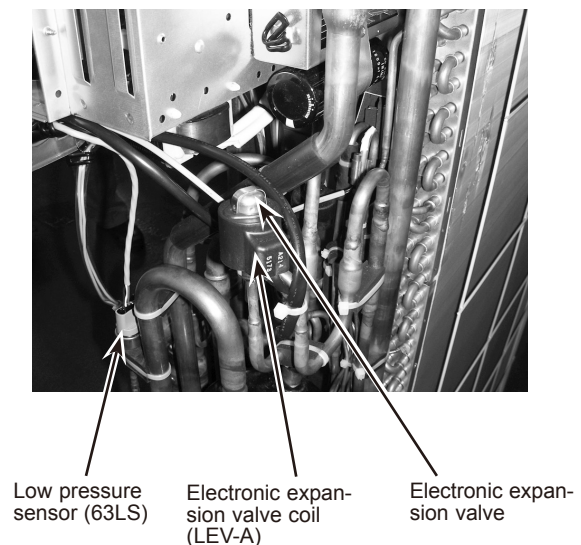

Photo 12



OPERATING PROCEDURE

13. Removing the compressor (MC)

- (1) Remove the service panel. (See Photo 1)
- (2) Remove the top panel. (See Photo 1)
- (3) Remove 2 front cover panel fixing screws (5 × 12) and remove the front cover panel. (See Photo 4)
- (4) Remove front panel fixing screws, 5 (5x12) and 2 (4 x 10) and remove the front panel. (See Photo 4)
- (5) Remove 4 back cover panel fixing screws (5 × 12) and remove the back cover panel.
- (6) Remove the electrical parts box. (See Photo 5)
- (7) Remove 3 valve bed fixing screws (4 × 10) and 4 ball valve and stop valve fixing screws (5 × 16) and then remove the valve bed. (See Photo 4 and 7)
- (8) Remove 3 right side panel fixing screw (5 × 12) in the rear of the unit and then remove the right side panel.
- (9) Remove 3 separator fixing screws (4 × 10) and remove the separator. (See Figure 1)
- (10) Recover refrigerant.
- (11) Remove the 3 compressor fixing nuts for motor using spanner or adjustable wrench.
- (12) Remove the welded pipe of motor for compressor inlet and outlet and then remove the compressor.

Note: Recover refrigerant without spreading it in the air.

PHOTOS

Photo 13

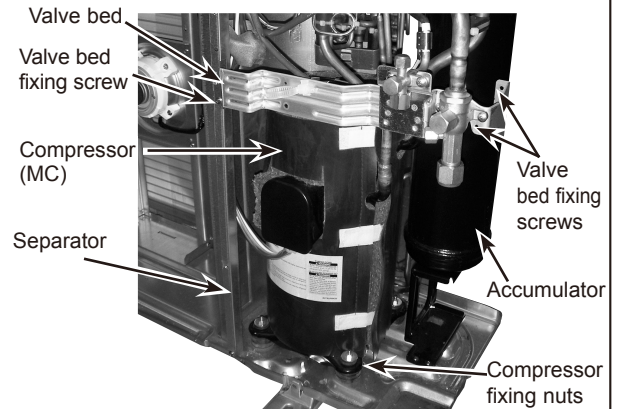
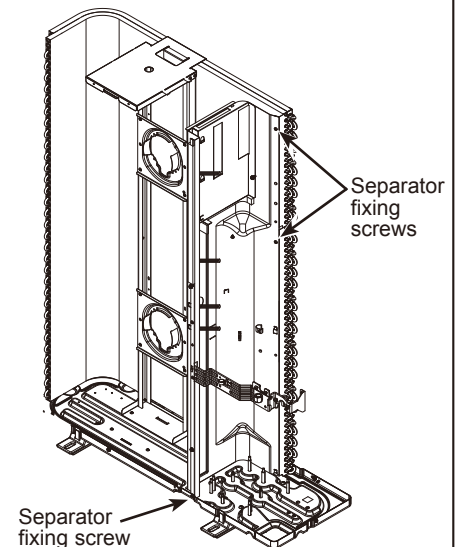

Figure 1



14. Removing the accumulator

- (1) Remove the service panel. (See Photo 1)
- (2) Remove the top panel. (See Photo 1)
- (3) Remove 2 front cover panel fixing screws (5 × 12) and remove the front cover panel. (See Photo 4)
- (4) Remove 4 back cover panel fixing screws (5 × 12) and remove the back cover panel.
- (5) Remove the electrical parts box. (See Photo 5)
- (6) Remove 3 valve bed fixing screws (4 × 10) and 4 ball valve and stop valve fixing screws (5 × 16), and then remove the valve bed. (See Photo 4 and 7)
- (7) Remove 3 right side panel fixing screw (5 × 12) in the rear of the unit and then remove the right side panel.
- (8) Recover refrigerant.
- (9) Remove 2 welded pipes of accumulator inlet and outlet.
- (10) Remove 2 accumulator leg fixing screws (4 × 10). (See Photo 15)

Note: Recover refrigerant without spreading it in the air.

Photo 14

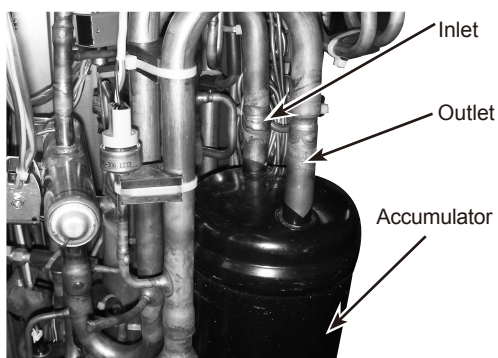
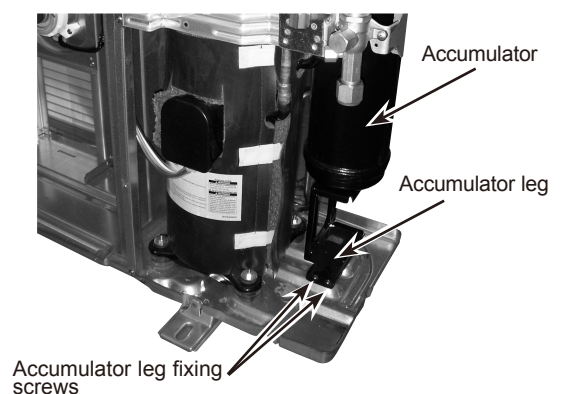
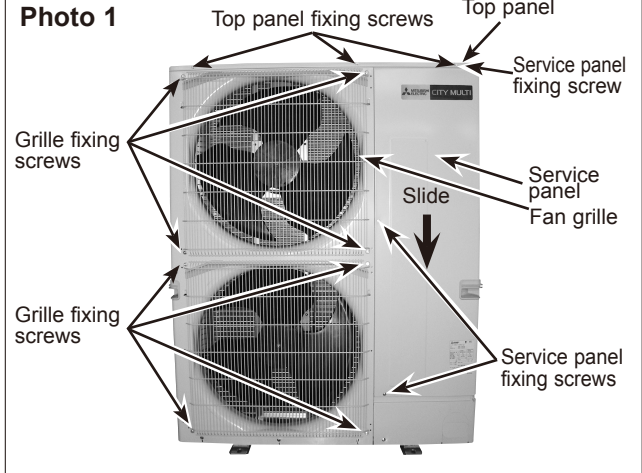
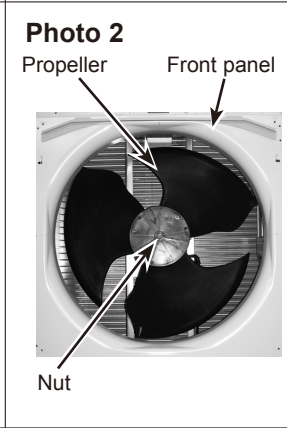
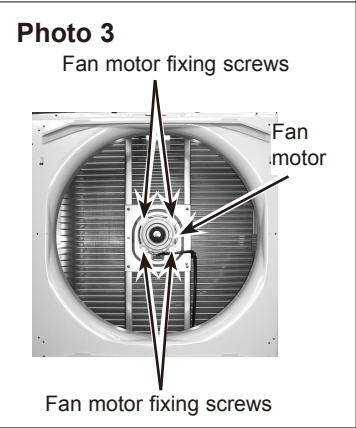
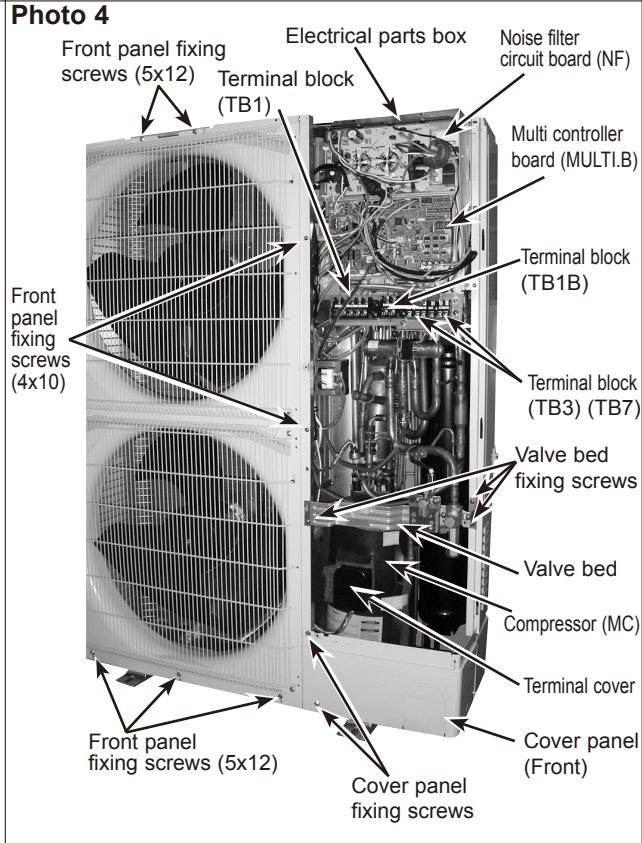

Photo 15



PUMY-P112YKM(-BS)
PUMY-P125YKM(-BS)
PUMY-P140YKM(-BS)

Note: Turn OFF the power supply before disassembly.

OPERATING PROCEDURE	PHOTOS & ILLUSTRATION
<p>1. Removing the service panel and top panel</p> <p>(1) Remove 3 service panel fixing screws (5 × 12) and slide the hook on the right downward to remove the service panel.</p> <p>(2) Remove screws (3 for front, 3 for rear/5 × 12) of the top panel and remove it.</p>	<p>Photo 1</p> 
<p>2. Removing the fan motor (MF1, MF2)</p> <p>(1) Remove the service panel. (See Photo 1)</p> <p>(2) Remove the top panel. (See Photo 1)</p> <p>(3) Remove 4 fan grille fixing screws (5 × 12) to detach the fan grille. (See Photo 1)</p> <p>(4) Remove a nut (for right handed screw of M6) to detach the propeller. (See Photo 2.)</p> <p>(5) Disconnect the connectors, CNF1 and CNF2 on multi controller board in electrical parts box.</p> <p>(6) Remove 4 fan motor fixing screws (5 × 20) to detach the fan motor. (See Photo 3)</p>	<p>Photo 2</p>  <p>Photo 3</p> 
<p>3. Removing the electrical parts box</p> <p>(1) Remove the service panel. (See Photo 1)</p> <p>(2) Remove the top panel. (See Photo 1)</p> <p>(3) Disconnect the connecting wire from terminal block.</p> <p>(4) Remove all the following connectors from multi controller board;</p> <p><Diagram symbol in the connector housing></p> <ul style="list-style-type: none"> • Fan motor (CNF1, CNF2) • Thermistor <HIC pipe> (TH2) • Thermistor <Outdoor liquid pipe> (TH3) • Thermistor <Compressor> (TH4) • Thermistor <Suction pipe/Ambient, Outdoor> (TH6/7) • High pressure switch (63H) • High pressure sensor (63HS) • Low pressure sensor (63LS) • 4-way valve (21S4) • Bypass valve (SV1) <p>Pull out the disconnected wire from the electrical parts box.</p> <p>(5) Remove the terminal cover and disconnect the compressor lead wire.</p>	<p>Photo 4</p> 

Continue to the next page

From the previous page.

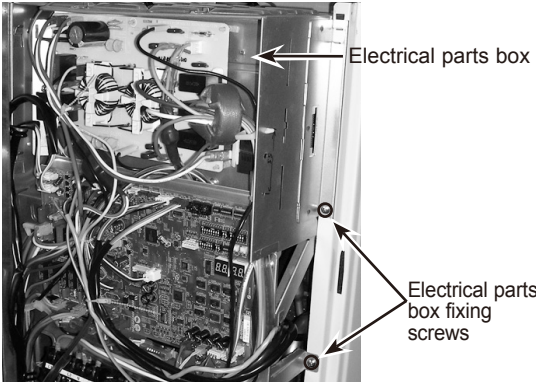
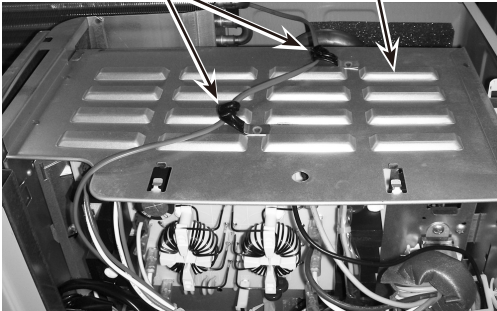
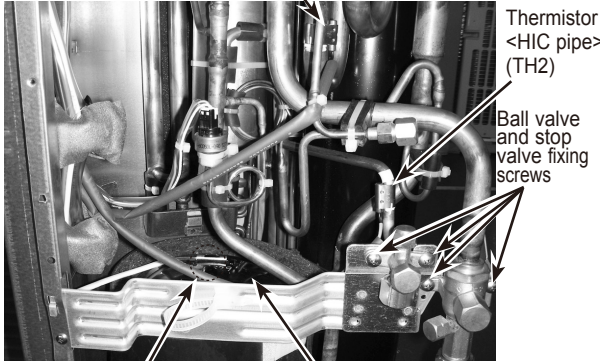
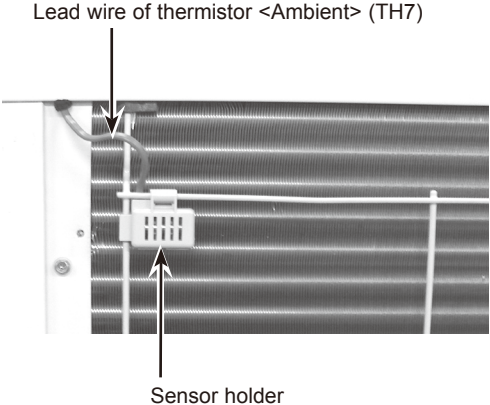
OPERATING PROCEDURE	PHOTOS & ILLUSTRATION
<p>(6) Remove 2 electrical parts box fixing screws (4 × 10) and detach the electrical parts box by pulling it upward. The electrical parts box is fixed with 2 hooks on the left and 1 hook on the right.</p>	<p>Photo 5</p> 
<p>4. Removing the thermistor <Suction pipe> (TH6)</p> <ol style="list-style-type: none"> (1) Remove the service panel. (See Photo 1) (2) Remove the top panel. (See Photo 1) (3) Disconnect the connectors, TH6 and TH7 (red), on the Multi controller board in the electrical parts box. (4) Loosen the wire clamps on top of the electrical parts box. (5) Pull out the thermistor <Suction pipe> (TH6) from the sensor holder. <p>Note: When replacing thermistor <Suction pipe> (TH6), replace it together with thermistor <Ambient> (TH7) since they are combined together. Refer to procedure No.5 below to remove thermistor <Ambient> (TH7).</p>	<p>Photo 6</p>  <p>Photo 7</p> 
<p>5. Removing the thermistor <Ambient> (TH7)</p> <ol style="list-style-type: none"> (1) Remove the service panel. (See Photo 1) (2) Remove the top panel. (See Photo 1) (3) Disconnect the connector TH7 (red) on the multi controller board in the electrical parts box. (4) Loosen the wire clamps on top of the electrical parts box. (See Photo 6.) (5) Pull out the thermistor <Ambient> (TH7) from the sensor holder. <p>Note: When replacing thermistor <Ambient> (TH7), replace it together with thermistor <Suction pipe> (TH6), since they are combined together. Refer to procedure No.4 above to remove thermistor <Suction pipe> (TH6).</p>	<p>Photo 8</p> 

OPERATING PROCEDURE

6. Removing the thermistor <Outdoor liquid pipe> (TH3) and thermistor <Compressor> (TH4), thermistor <HIC pipe> (TH2)

- (1) Remove the service panel. (See Photo 1)
- (2) Disconnect the connectors, TH3 (white) and TH4 (white), TH2 (black) on the multi controller board in the electrical parts box.
- (3) Loosen the clamp for the lead wire in the rear of the electrical parts box.
- (4) Pull out the thermistor <Outdoor liquid pipe> (TH3) and thermistor <Compressor> (TH4) from the sensor holder. (See Photo 7 and 9)

7. Removing the 4-way valve coil (21S4)

- (1) Remove the service panel. (See Photo 1)

[Removing the 4-way valve coil]

- (2) Remove 4-way valve coil fixing screw (M5 × 7).
- (3) Remove the 4-way valve coil by sliding the coil toward you.
- (4) Disconnect the connector 21S4 (green) on the multi controller board in the electrical parts box.

8. Removing the 4-way valve

- (1) Remove the service panel. (See Photo 1)
- (2) Remove the top panel. (See Photo 1)
- (3) Remove the electrical parts box. (See Photo 5)
- (4) Remove 3 valve bed fixing screws (4 × 10) and 4 ball valve and stop valve fixing screws (5 × 16) and then remove the valve bed. (See Photo 4 and 7)
- (5) Remove 4 right side panel fixing screws (5 × 12) in the rear of the unit and then remove the right side panel.
- (6) Remove the 4-way valve coil. (See Photo 10)
- (7) Recover refrigerant.
- (8) Remove the welded part of 4-way valve.

Note 1: Recover refrigerant without spreading it in the air.

Note 2: The welded part can be removed easily by removing the right side panel.

Note 3: When installing the four-way valve, cover it with a wet cloth to prevent it from heating (120°C or more), then braze the pipes so that the inside of pipes are not oxidized.

PHOTOS

Photo 9

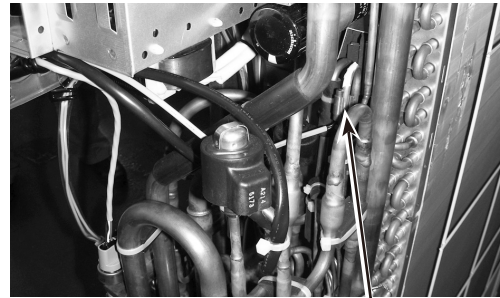

Thermistor
<Outdoor liquid pipe> (TH3)

Photo 10

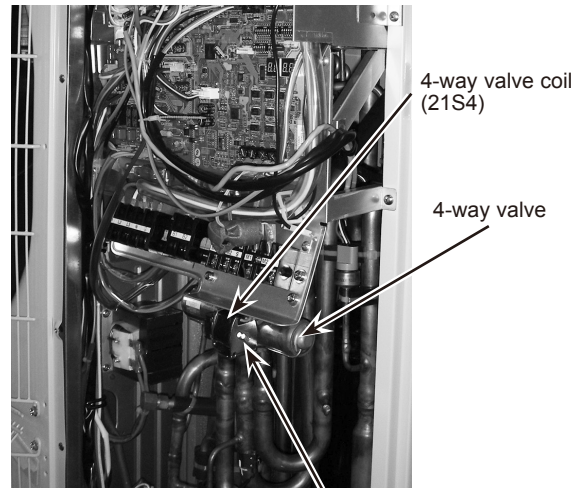

4-way valve coil
(21S4)

4-way valve

4-way valve coil
fixing screw

OPERATING PROCEDURE

9. Removing bypass valve coil (SV1) and bypass valve

- (1) Remove the service panel. (See Photo 1)
- (2) Remove the top panel. (See Photo 1)
- (3) Remove 3 right side panel fixing screws (5 × 12) in the rear of the unit and remove the right side panel.
- (4) Remove the bypass valve coil fixing screw (M4 × 6).
- (5) Remove the bypass valve coil by sliding the coil upward.
- (6) Disconnect the connector SV1 (gray) on the multi controller circuit board in the electrical parts box.
- (7) Remove the electrical parts box. (See Photo 5)
- (8) Recover refrigerant.
- (9) Remove the welded part of bypass valve.

Note 1: Recover refrigerant without spreading it in the air.

Note 2: The welded part can be removed easily by removing the right side panel.

Note 3: When installing the bypass valve, cover it with a wet cloth to prevent it from heating (120°C or more), then braze the pipes so that the inside of pipes are not oxidized.

10. Removing the high pressure switch (63H) and high pressure sensor (63HS)

- (1) Remove the service panel. (See Photo 1)
- (2) Remove the top panel. (See Photo 1)
- (3) Remove 3 right side panel fixing screws (5 × 12) in the rear of the unit and remove the right side panel.
- (4) Pull out the lead wire of high pressure switch and high pressure sensor.
- (5) Remove the electrical parts box. (See Photo 5)
- (6) Recover refrigerant.
- (7) Remove the welded part of high pressure switch and high pressure sensor.

Note 1: Recover refrigerant without spreading it in the air.

Note 2: The welded part can be removed easily by removing the right side panel.

Note 3: When installing the high pressure switch and high pressure sensor, cover them with a wet cloth to prevent them from heating (100°C or more), then braze the pipes so that the inside of pipes are not oxidized.

11. Removing the low pressure sensor (63LS)

- (1) Remove the service panel. (See Photo 1)
- (2) Remove the top panel. (See Photo 1)
- (3) Remove 3 right side panel fixing screws (5 × 12) in the rear of the unit and remove the right side panel.
- (4) Disconnect the connector 63LS (blue) on the multi controller circuit board in the electrical parts box.
- (5) Remove the electrical parts box. (See Photo 5)
- (6) Recover refrigerant.
- (7) Remove the welded part of low pressure sensor.

Note 1: Recover refrigerant without spreading it in the air.

Note 2: The welded part can be removed easily by removing the right side panel.

Note 3: When installing the low pressure sensor, cover it with a wet cloth to prevent it from heating (100°C or more), then braze the pipes so that the inside of pipes are not oxidized.

12. Removing electrical expansion valve (LEV-A, LEV-B)

- (1) Remove the service panel. (See Photo 1)
- (2) Remove the top panel. (See Photo 1)
- (3) Remove 3 right side panel fixing screws (5 × 12) in the rear of the unit and remove the right side panel.
- (4) Remove the electrical expansion valve coil. (See Photo 11,12)
- (5) Remove the electrical parts box. (See Photo 5)
- (6) Recover refrigerant.
- (7) Remove the welded part of electrical expansion valve.

PHOTOS

Photo 11

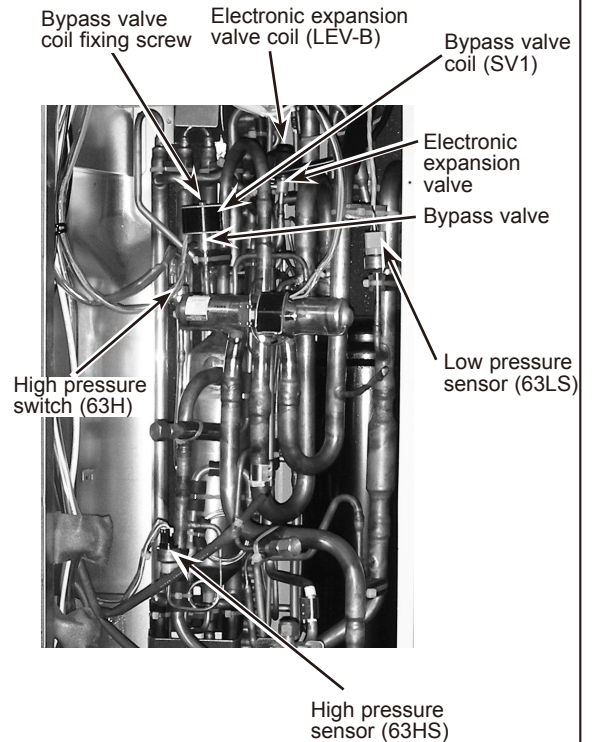
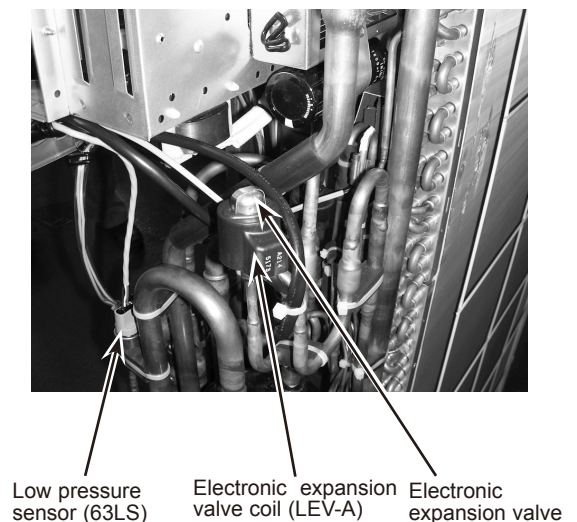

Photo 12



OPERATING PROCEDURE

13. Removing the reactor (DCL)

- (1) Remove the service panel. (See Photo 1)
- (2) Disconnect the lead wires from the reactor.
- (3) Remove the 4 screws, that fix the reactor box.
(See Photo 13)
- (4) Remove the reactor box.

Note 1: The reactor is very heavy! Be careful when handling it.

PHOTOS

Photo 13

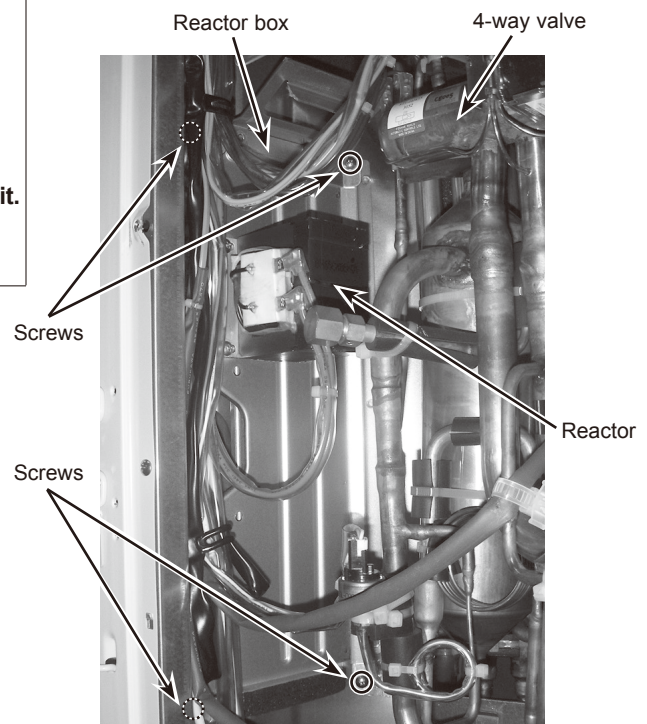

OPERATING PROCEDURE

14. Removing the compressor (MC)

- (1) Remove the service panel. (See Photo 1)
- (2) Remove the top panel. (See Photo 1)
- (3) Remove 2 front cover panel fixing screws (5 × 12) and remove the front cover panel. (See Photo 4)
- (4) Remove front panel fixing screws, 5 (5x12) and 2 (4 x 10) and remove the front panel. (See Photo 4)
- (5) Remove 4 back cover panel fixing screws (5 × 12) and remove the back cover panel.
- (6) Remove the electrical parts box. (See Photo 5)
- (7) Remove 3 valve bed fixing screws (4 × 10) and 4 ball valve and stop valve fixing screws (5 × 16) and then remove the valve bed. (See Photo 4 and 7)
- (8) Remove 3 right side panel fixing screw (5 × 12) in the rear of the unit and then remove the right side panel.
- (9) Remove 3 separator fixing screws (4 × 10) and remove the separator. (See Figure 1)
- (10) Recover refrigerant.
- (11) Remove the 3 compressor fixing nuts for motor using spanner or adjustable wrench.
- (12) Remove the welded pipe of motor for compressor inlet and outlet and then remove the compressor.

Note: Recover refrigerant without spreading it in the air.

PHOTOS

Photo 14

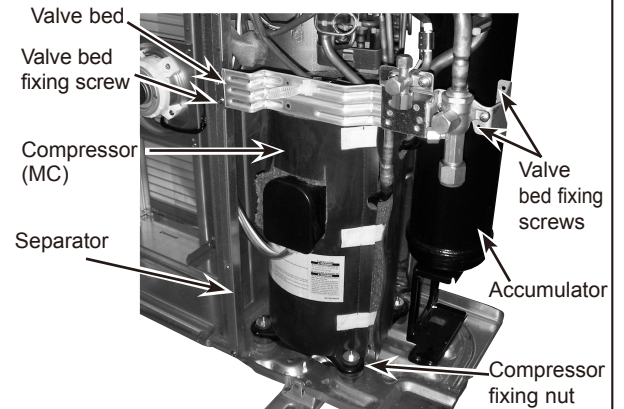
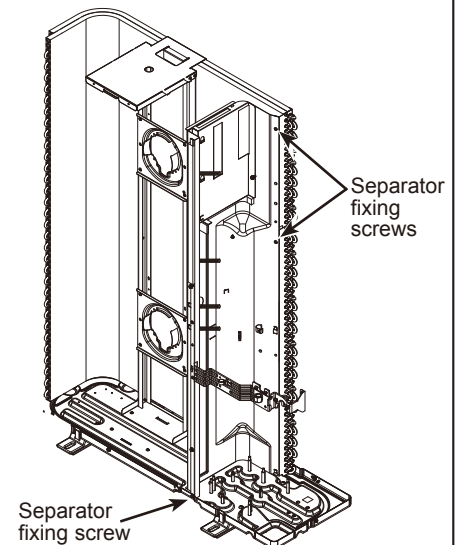

Figure 1



15. Removing the accumulator

- (1) Remove the service panel. (See Photo 1)
- (2) Remove the top panel. (See Photo 1)
- (3) Remove 2 front cover panel fixing screws (5 × 12) and remove the front cover panel. (See Photo 4)
- (4) Remove 4 back cover panel fixing screws (5 × 12) and remove the back cover panel.
- (5) Remove the electrical parts box. (See Photo 5)
- (6) Remove 3 valve bed fixing screws (4 × 10) and 4 ball valve and stop valve fixing screws (5 × 16) , and then remove the valve bed. (See Photo 4 and 7)
- (7) Remove 3 right side panel fixing screw (5 × 12) in the rear of the unit and then remove the right side panel.
- (8) Recover refrigerant.
- (9) Remove 2 welded pipes of accumulator inlet and outlet.
- (10) Remove 2 accumulator leg fixing screws (4 × 10). (See Photo 16)

Note: Recover refrigerant without spreading it in the air.

Photo 15

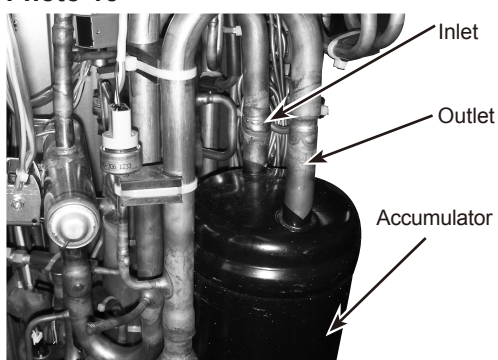
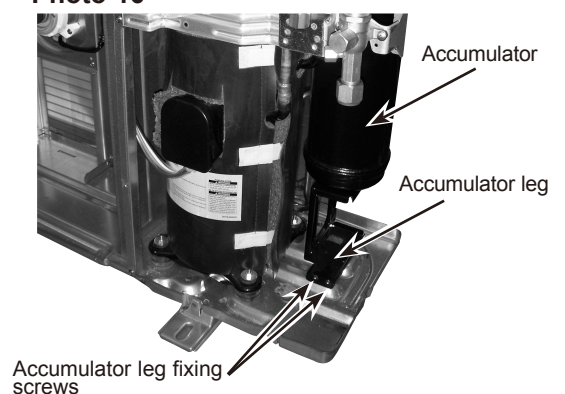

Photo 16



CITY MULTI™

mitsubishi
mitsubishi ELECTRIC CORPORATION

HEAD OFFICE : TOKYO BLDG., 2-7-3, MARUNOUCHI, CHIYODA-KU, TOKYO100-8310, JAPAN
