

Air Conditioning

Product Information

PUHY-P200YKB-A1
Heat Pump Outdoor Unit

Making a
World of
Difference

CITY MULTI



The City Multi Y Series makes use of a two pipe refrigerant circuit throughout, with branch pipes feeding indoor units, allowing manual changeover from cooling to heating to ensure that a constant indoor climate is maintained.

Key Features

- Designed from day 1 for seasonal efficiency
- New energy-saving inverter driven compressor with very low start currents
- Reduced standby power by up to 50% using induction heated compressor
- By changing the system evaporating temperature, there are various options for indoor units to offer increased air off temperatures, higher SHF and improved comfort, with the benefit of energy saving
- A choice of standard reverse defrost or a continued supply of heating during the defrost cycle



Air Conditioning | Heating
Ventilation | Controls

Air Conditioning

Product Information

PUHY-P200YKB-A1 Heat Pump Outdoor Unit

Making a
World of
Difference

PUHY - OUTDOOR UNIT		PUHY-P200YKB-A1
CAPACITY (kW)	Heating (nominal)	25.0
	Cooling (nominal)	22.4
	High Performance Heating (UK)	25.0
	COP Priority Heating (UK)	22.8
	Cooling (UK)	20.0
POWER INPUT (kW)	Heating (nominal)	5.81
	Cooling (nominal)	5.19
	High Performance Heating (UK)	7.32
	COP Priority Heating (UK)	5.75
	Cooling (UK)	3.01
COP / EER (nominal)		4.30 / 4.31
SCOP / SEER (system)		5.08 / 8.12
MAX No. OF CONNECTABLE INDOOR UNITS		17
MAX CONNECTABLE CAPACITY		50-130% OU Capacity
AIRFLOW (m ³ /min)	High	175
	Gas	22.2 (7/8")
PIPE SIZE mm (in)	Gas	9.52 (3/8")
	Liquid	9.52 (3/8")
SOUND PRESSURE LEVEL (dBA)		57
SOUND POWER LEVEL (dBA)		78
WEIGHT (kg)		190
DIMENSIONS (mm)		
	Width	920
	Depth	740
(1650mm without legs)	Height	1710
ELECTRICAL SUPPLY*		380-415v, 50Hz
PHASE*		Three
STARTING CURRENT (A)*		8
NOMINAL SYSTEM RUNNING CURRENT (A)*		9.3 / 8.3 [16.1]
Heating / Cooling [MAX]		
GUARANTEED OPERATING RANGE (°C)		-20~-15.5 / -5~-52
Heating / Cooling		
FUSE RATING (MCB sizes BS EN 60947-2) - (A)*		1 x 20
MAINS CABLE No. Cores*		4 + earth

Note: * A separate power supply is required for each module.



DIMENSIONS

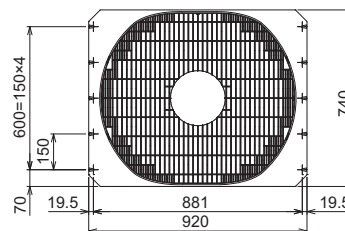
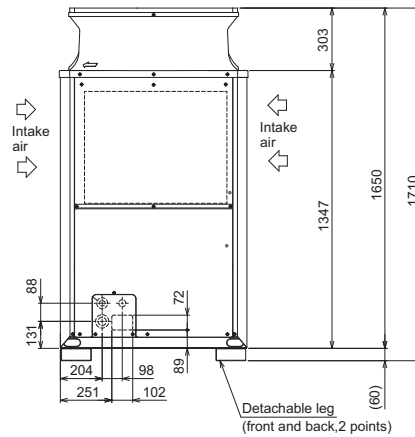
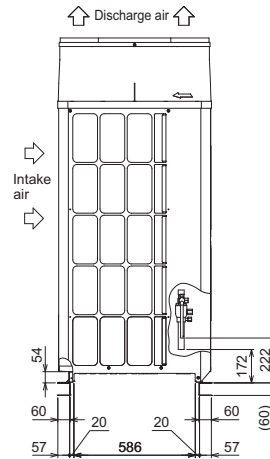

Telephone: 01707 282880

email: air.conditioning@meuk.mee.com web: www.airconditioning.mitsubishielectric.co.uk

UNITED KINGDOM Mitsubishi Electric Europe Living Environmental Systems Division
Travellers Lane, Hatfield, Hertfordshire, AL10 8XB, England General Enquiries Telephone: 01707 282880 Fax: 01707 278881

IRELAND Mitsubishi Electric Europe Westgate Business Park, Ballymount, Dublin 24, Ireland
Telephone: Dublin (01) 419 8800 Fax: Dublin (01) 419 8890 International code: (003531)

Country of origin: United Kingdom - Japan - Thailand - Malaysia. ©Mitsubishi Electric Europe 2015. Mitsubishi and Mitsubishi Electric are trademarks of Mitsubishi Electric Europe B.V. The company reserves the right to make any variation in technical specification to the equipment described, or to withdraw or replace products without prior notification or public announcement. Mitsubishi Electric is constantly developing and improving its products. All descriptions, illustrations, drawings and specifications in this publication present only general particulars and shall not form part of any contract. All goods are supplied subject to the Company's General Conditions of Sale, a copy of which is available on request. Third-party product and brand names may be trademarks or registered trademarks of their respective owners.



Note: The fuse rating is for guidance only. Please refer to the relevant databook for detailed specification. It is the responsibility of a qualified electrician/electrical engineer to select the correct cable size and fuse rating based on current regulation and site specific conditions. Mitsubishi Electric's air conditioning and heat pump systems contain fluorinated greenhouse gases R410A, R407C and R134a.



www.greengateway.mitsubishielectric.co.uk

Mitsubishi Electric UK's commitment
to the environment

Follow us @meuk_les
Follow us @green_gateway

Mitsubishi Electric
Living Environmental Systems UK

mitsubishielectric2

Effective as of April 2015