

# **SERVICE PARTS LIST FOR MITSUBISHI ELECTRIC PACKAGED AIR-CONDITIONERS**

**Series PUD-P250YMF-C (-BS,-BF)  
PUY-P•YMF-C (-BS,-BF)  
PUHY-P•YMF-C (-BS,-BF)**

**REVISED  
Aug. 2004**

**For use with the R407C**

## **INDEX**

**PUD-P250YMF-C  
PUD-P250YMF-C-BS  
PUD-P250YMF-C-BF  
PU(H)Y-P200YMF-C  
PU(H)Y-P250YMF-C  
PU(H)Y-P200YMF-C-BS  
PU(H)Y-P250YMF-C-BS  
PU(H)Y-P200YMF-C-BF  
PU(H)Y-P250YMF-C-BF**



PUD-P250YMF-C (-BS,-BF)  
PUY-P200,P250YMF-C (-BS,-BF)  
PUHY-P200,P250YMF-C (-BS,-BF)

### EXTERNAL PARTS

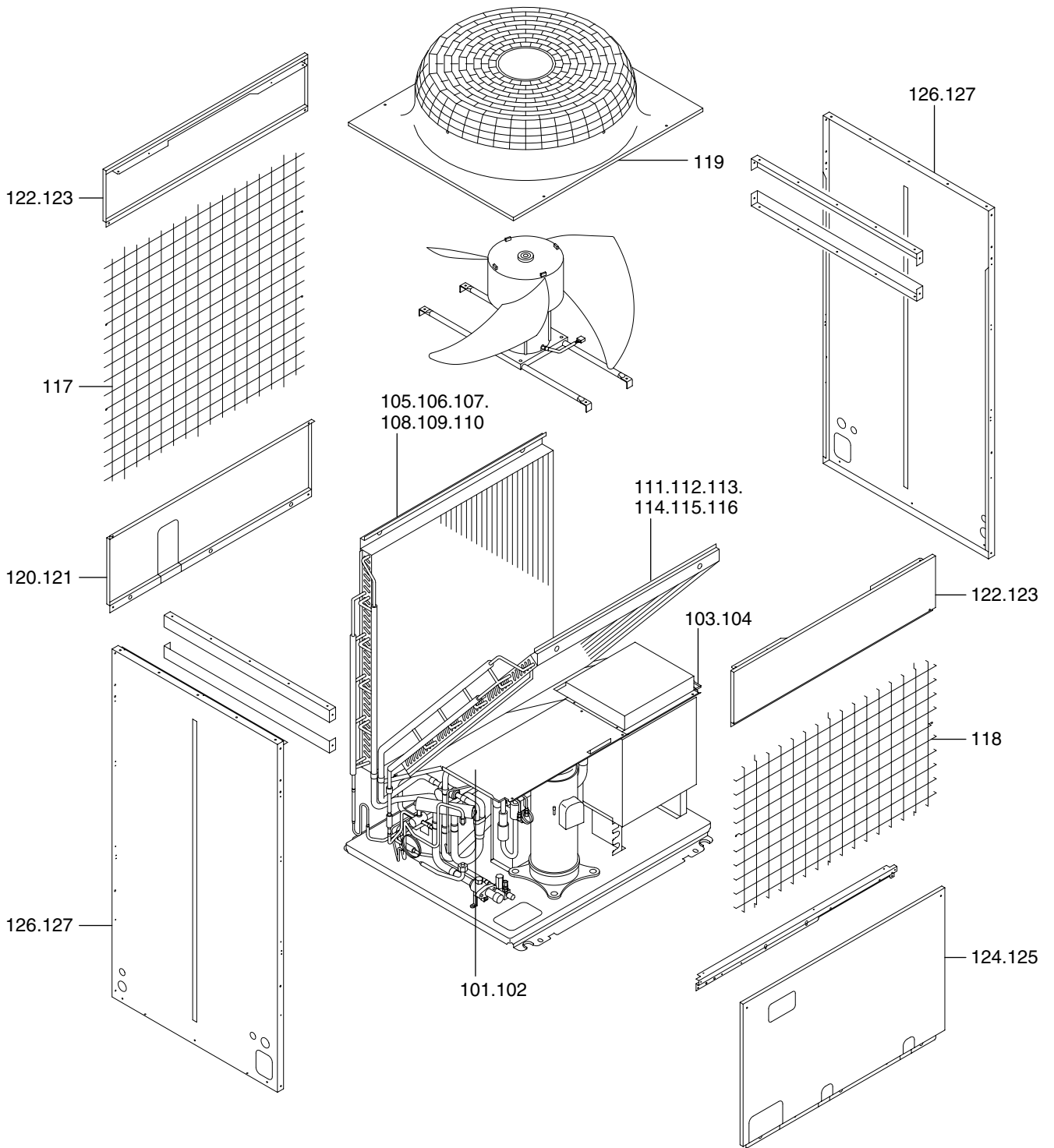

PUD-P250YMF-C (-BS,-BF)  
 PUY-P200,P250YMF-C (-BS,-BF)  
 PUHY-P200,P250YMF-C (-BS,-BF)

EXTERNAL PARTS

No.	Part No.	Part Name	Spec.	PUD-P250YMF-C	PUD-P250YMF-C-BS	PUD-P250YMF-C-BF	PUHY-P200YMF-C	PUHY-P250YMF-C	PUHY-P200YMF-C-BS	PUHY-P250YMF-C-BS	PUHY-P200YMF-C-BF	PUHY-P250YMF-C-BF	Dwg. No.	Price
101	R61 Y06 629	Partition board L assy		1		1	1	1			1	1	W639800G01	
102	R61 Y09 629	Partition board L assy			1				1	1			W639800G02	
103	R61 Y07 629	Partition board R assy		1		1	1	1			1	1	W639809G05	
104	R61 Y10 629	Partition board R assy			1				1	1			W639809G06	
105	R61 Y99 480	Heat exchanger B					1						W268979G06	
106	R61 Y17 481	Heat exchanger B							1				W268979G07	
107	R61 Y18 481	Heat exchanger B									1		W268979G08	
108	R61 L02 480	Heat exchanger B		1				1					W126026G23	
109	R61 L03 480	Heat exchanger B			1				1				W126026G24	
110	R61 Y19 481	Heat exchanger B				1						1	W126026G26	
111	R61 H13 409	Heat exchanger F					1						W125262G14	
112	R61 H15 409	Heat exchanger F							1				W125262G16	
113	R61 Y21 481	Heat exchanger F									1		W125262G18	
114	R61 L02 481	Heat exchanger F		1				1					W268980G11	
115	R61 L03 481	Heat exchanger F			1				1				W268980G12	
116	R61 Y22 481	Heat exchanger F				1						1	W268980G13	
117	R61 A42 638	Guard B assy		1	1	1	1	1	1	1	1	1	W265789G01	
118	R61 E66 611	Guard F assy		1	1	1	1	1	1	1	1	1	W265788G01	
119	R61 A52 118	Fan guard		1	1	1	1	1	1	1	1	1	W123195G01	
120	R61 L78 651	Panel B assy		1		1	1	1			1	1	W615886H09	
121	R61 Y01 677	Panel B assy			1				1	1			W615886G13	
122	R61 L78 653	Panel FU		2		2	2	2			2	2	W633746H06	
123	R61 N78 653	Panel FU			2				2	2			W633746G06	
124	R61 Y13 652	Panel F assy		1		1	1	1			1	1	W857425G26	
125	R61 Y14 652	Panel F assy			1				1	1			W857425G38	
126	R61 N78 661	Panel S		2		2	2	2			2	2	W272421H01	
127	R61 N78 662	Panel S			2				2	2			W272421H02	

PUD-P250YMF-C (-BS,-BF)  
 PUY-P200YMF-C (-BS,-BF)  
 PUY-P250YMF-C (-BS,-BF)

FUNCTIONAL PARTS (1)

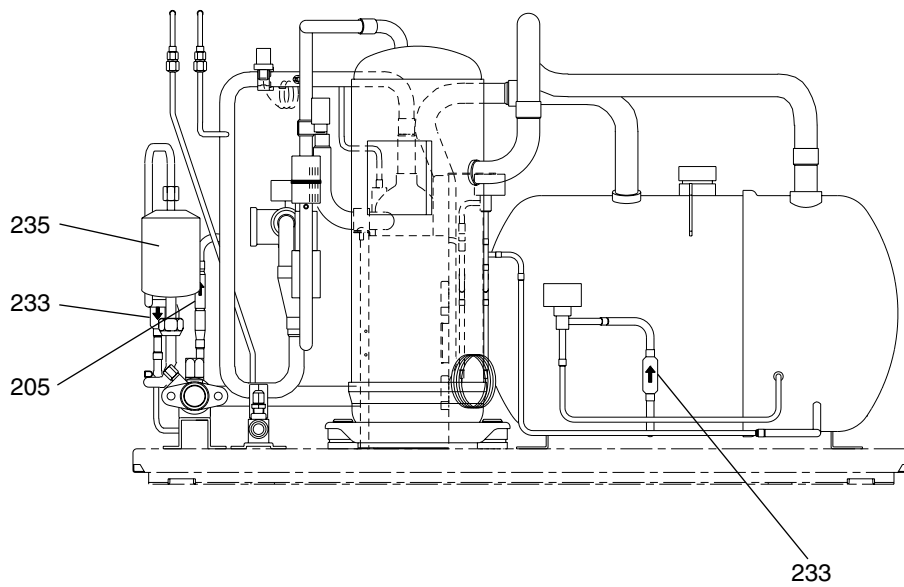
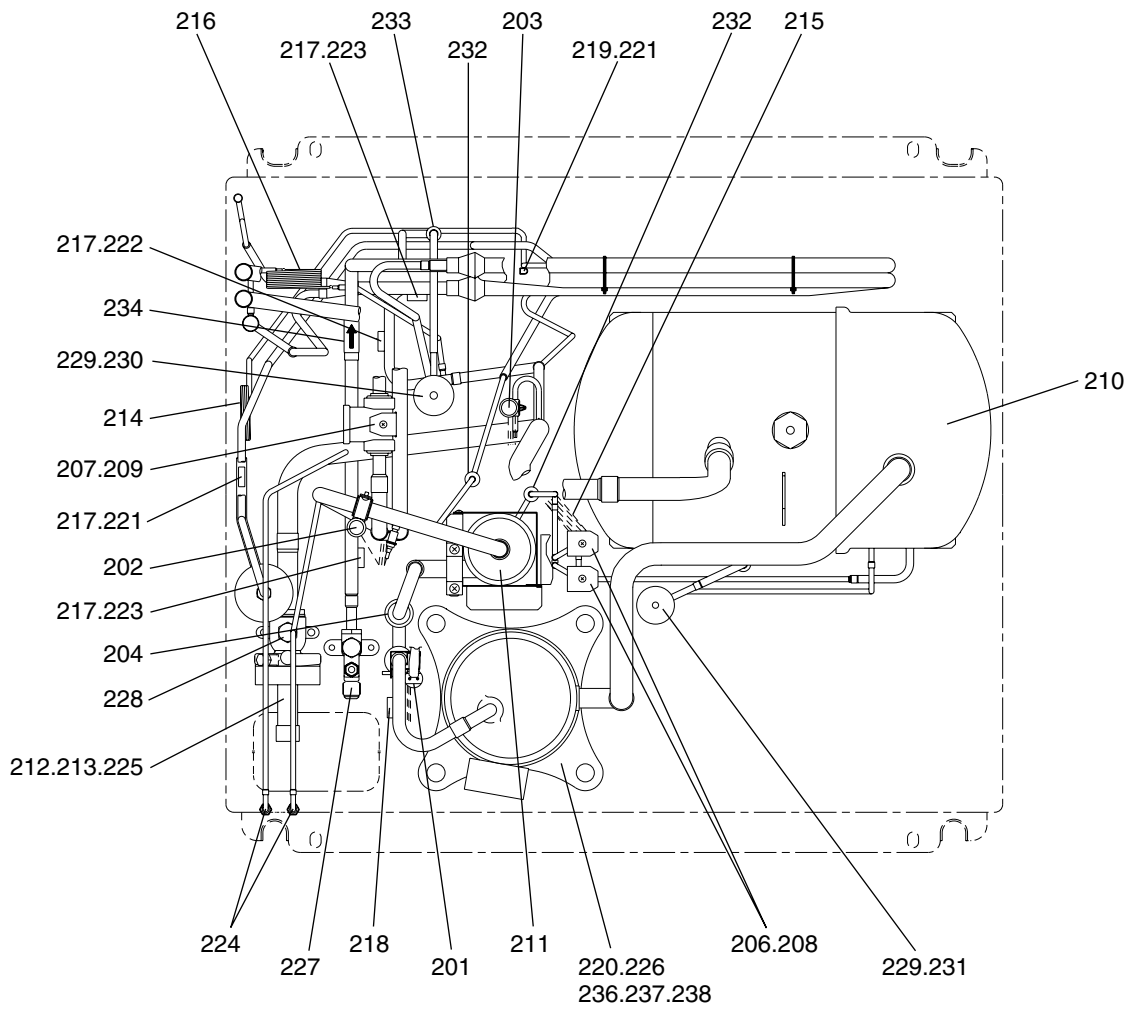

PUD-P250YMF-C (-BS,-BF)  
PUY-P200YMF-C (-BS,-BF)  
PUY-P250YMF-C (-BS,-BF)

FUNCTIONAL PARTS (1)

No.	Part No.	Part Name	Spec.									Dwg. No.	Price	
				PUD-P250YMF-C	PUD-P250YMF-C-BS	PUD-P250YMF-C-BF	PUY-P200YMF-C	PUY-P250YMF-C	PUY-P200YMF-C-BS	PUY-P250YMF-C-BS	PUY-P200YMF-C-BF			PUY-P250YMF-C-BF
201	R61 Y06 208	Pressure switch	ACB-1TB 10W,<63H>	1	1	1	1	1	1	1	1	1	P426258X02	
202	R61 331 288	Pressure sensor	<63HS>	1	1	1	1	1	1	1	1	1	P419110X01	
203	R61 G35 288	Pressure sensor	<63LS>	1	1	1	1	1	1	1	1	1	P419129X01	
204	R61 F14 418	Check valve		1	1	1	1	1	1	1	1	1	P639130X01	
205	R61 625 418	Check valve		1	1	1	1	1	1	1	1	1	S639001H02	
206	R61 435 232	Solenoid valve	NEV-202DXF	2	2	2	2	2	2	2	2	2	P631807X02	
207	R61 G57 232	Solenoid valve	ST66PF	1	1	1	1	1	1	1	1	1	P631227X02	
208	R61 Y04 243	Solenoid valve coil	NEV,<SV1,2>	2	2	2	2	2	2	2	2	2	P631205X01	
209	R61 Y08 243	Solenoid valve coil	ST,<SV3>	1	1	1	1	1	1	1	1	1	P631249X01	
210	R61 Y31 484	Accumulator assy		1	1	1	1	1	1	1	1	1	W271964G02	
211	R61 M23 487	Oil separator assy		1	1	1	1	1	1	1	1	1	W639808G03	
212	R61 Y05 494	Pipe assy					1		1		1		W656083G03	
213	R61 Y06 494	Pipe assy		1	1	1			1			1	W656083G04	
214	R61 L85 425	Capillary tube processing	0.6X2.4-900	1	1	1	1	1	1	1	1	1	W888053G01	
215	R61 Y07 425	Capillary tube assy	1.2X3-2000	1	1	1	1	1	1	1	1	1	W883531G01	
216	R61 H79 425	Capillary tube processing	0.8X2.4-2000	1	1	1	1	1	1	1	1	1	W869801G01	
217	R61 670 202	Thermistor	NTH3A14,<TH5~9>	5	5	5	5	5	5	5	5	5	P425496X01	
218	R61 671 202	Thermistor	<TH1>	1	1	1	1	1	1	1	1	1	P425439X01	
219	R61 F14 200	Thermistor	<TH2>	1	1	1	1	1	1	1	1	1	P425565X01	
220	R61 375 200	Thermistor	<TH10>	1	1	1	1	1	1	1	1	1	P425438X01	
221	R61 A42 287	Sensor cover	EVA,6.35D	2	2	2	2	2	2	2	2	2	P227170X01	
222	R61 A45 287	Sensor cover	EVA,12.7D	1	1	1	1	1	1	1	1	1	P227171X01	
223	R61 A43 287	Sensor cover	EVA,16D	2	2	2	2	2	2	2	2	2	P227172X01	
224	R61 F14 413	Check joint		2	2	2	2	2	2	2	2	2	P639131X01	
225	R61 F14 514	Packing	T/# 1991-NF	1	1	1	1	1	1	1	1	1	P321009X01	
226	R61 Y08 262	Belt heater	240V 45W,<CH1>	1	1	1	1	1	1	1	1	1	P493642X02	
227	R61 F14 410	Ball valve	1/2	1	1	1	1	1	1	1	1	1	P636220X02	
228	R61 Y11 410	Ball valve	1 flange	1	1	1	1	1	1	1	1	1	P636311X01	
229	R61 G48 401	Linear expansion valve	DKV18	2	2	2	2	2	2	2	2	2	P632342X01	
230	R61 A45 401	Linear expansion valve coil	<LEV1>	1	1	1	1	1	1	1	1	1	P472017X01	
231	R61 A45 402	Linear expansion valve coil	<SLEV>	1	1	1	1	1	1	1	1	1	P472016X01	
232	R61 155 454	Strainer	6.35D	2	2	2	2	2	2	2	2	2	W882822G01	
233	R61 A42 454	Strainer	9.52D	3	3	3	3	3	3	3	3	3	W882823G01	
234	R61 Y02 454	Strainer		1	1	1	1	1	1	1	1	1	W858399G02	
235	R61 M57 405	Dryer		1	1	1	1	1	1	1	1	1	P641114X01	
236	R61 Y01 850	Insulator		1	1	1	1	1	1	1	1	1	W628447H02	
237	R61 Y02 850	Insulator		1	1	1	1	1	1	1	1	1	W861746H02	
238	R69 963 478	Scroll compressor	HEV92FA1-YB,<MC>	1	1	1	1	1	1	1	1	1	EP10013G08	

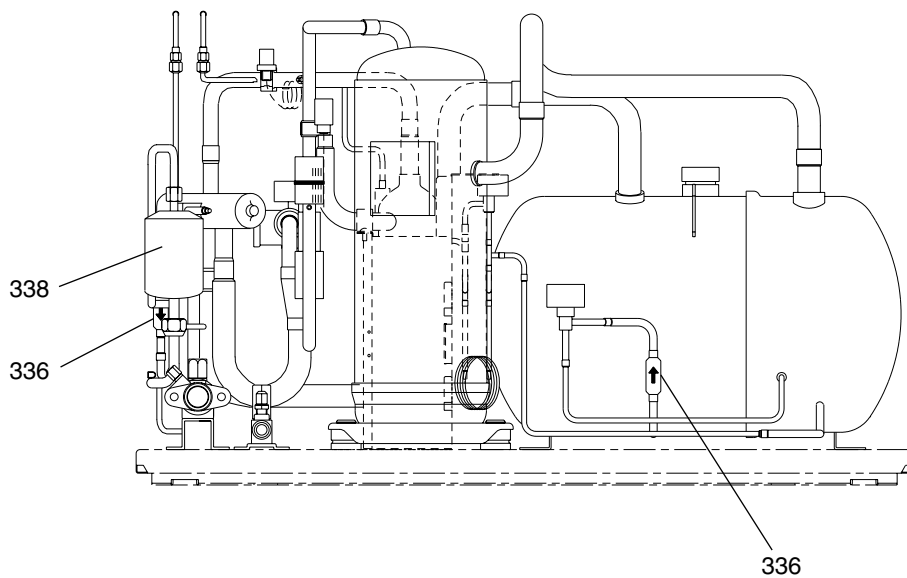
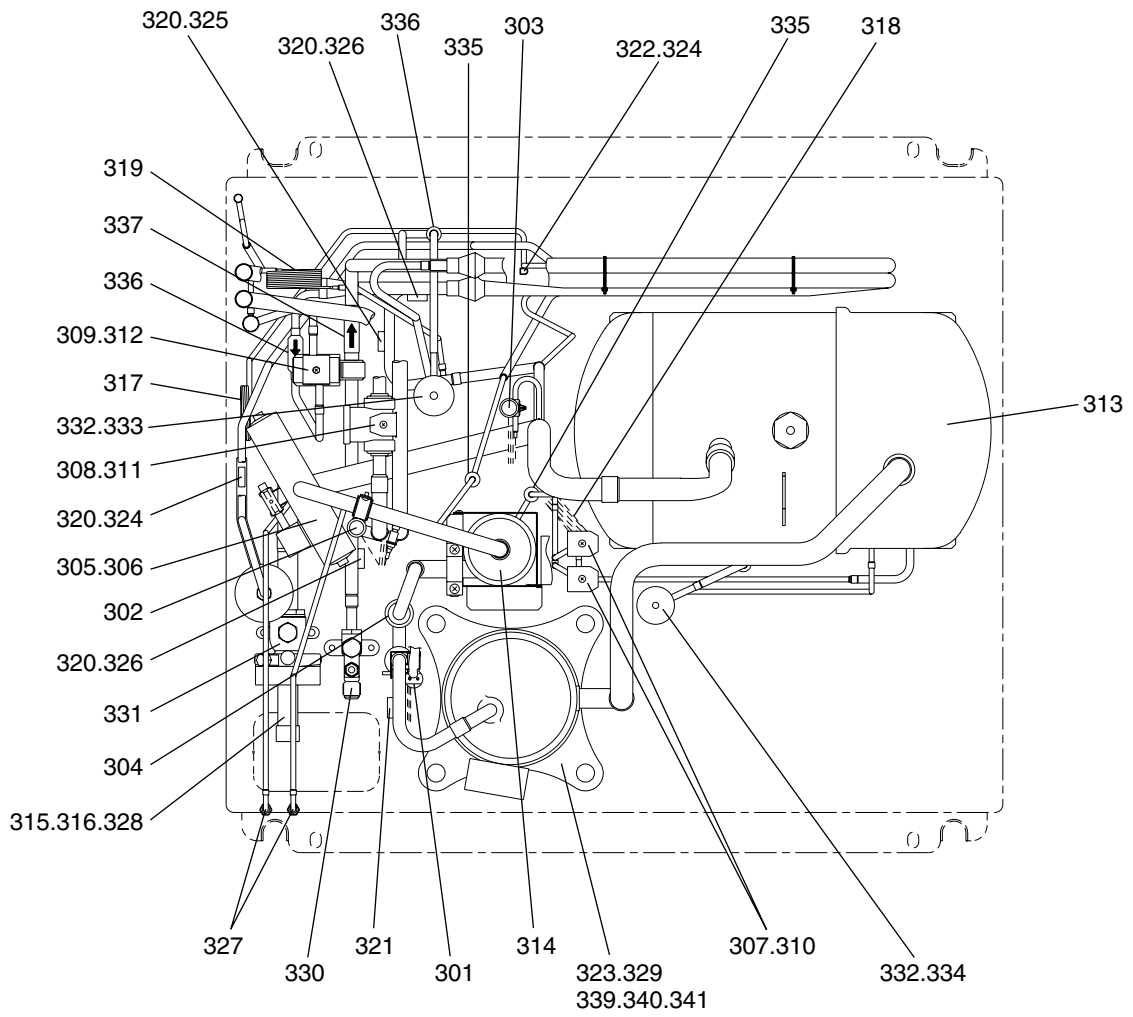

PUHY-P200YMF-C (-BS,-BF)  
 PUHY-P250YMF-C (-BS,-BF)

FUNCTIONAL PARTS (2)

No.	Part No.	Part Name	Spec.	PUHY-P200YMF-C	PUHY-P250YMF-C	PUHY-P200YMF-CBS	PUHY-P250YMF-CBS	PUHY-P200YMF-CBF	PUHY-P250YMF-CBF	Dwg. No.	Price
301	R61 Y06 208	Pressure switch	ACB-1TB 10W,<63H>	1	1	1	1	1	1	P426258X02	
302	R61 331 288	Pressure sensor	<63HS>	1	1	1	1	1	1	P419110X01	
303	R61 G35 288	Pressure sensor	<63LS>	1	1	1	1	1	1	P419129X01	
304	R61 F14 418	Check valve		1	1	1	1	1	1	P639130X01	
305	R61 R34 154	Four way valve	VH6100F	1	1	1	1	1	1	P633114X01	
306	R61 Y07 242	Four way valve coil	<21S4>	1	1	1	1	1	1	P633106X01	
307	R61 435 232	Solenoid valve	NEV-202DXF	2	2	2	2	2	2	P631807X02	
308	R61 G57 232	Solenoid valve	ST66PF	1	1	1	1	1	1	P631227X02	
309	R61 449 232	Solenoid valve		1	1	1	1	1	1	P631818X03	
310	R61 Y04 243	Solenoid valve coil	NEV,<SV1,2>	2	2	2	2	2	2	P631205X01	
311	R61 Y08 243	Solenoid valve coil	ST,<SV3>	1	1	1	1	1	1	P631249X01	
312	R61 Y03 232	Solenoid valve coil	SB18,<SV4>	1	1	1	1	1	1	P631246X01	
313	R61 Y31 484	Accumulator assy		1	1	1	1	1	1	W271964G02	
314	R61 M23 487	Oil separator assy		1	1	1	1	1	1	W639808G03	
315	R61 Y05 494	Pipe assy		1		1		1		W656083G03	
316	R61 Y06 494	Pipe assy			1		1		1	W656083G04	
317	R61 L85 425	Capillary tube processing	0.6X2.4-900	1	1	1	1	1	1	W888053G01	
318	R61 Y07 425	Capillary tube assy	1.2X3-2000	1	1	1	1	1	1	W883531G01	
319	R61 H79 425	Capillary tube processing	0.8X2.4-2000	1	1	1	1	1	1	W869801G01	
320	R61 670 202	Thermistor	NTH3A14,<TH5-9>	5	5	5	5	5	5	P425496X01	
321	R61 671 202	Thermistor	<TH1>	1	1	1	1	1	1	P425439X01	
322	R61 F14 200	Thermistor	<TH2>	1	1	1	1	1	1	P425565X01	
323	R61 375 200	Thermistor	<TH10>	1	1	1	1	1	1	P425438X01	
324	R61 A42 287	Sensor cover	EVA,6.35D	2	2	2	2	2	2	P227170X01	
325	R61 A45 287	Sensor cover	EVA,12.7D	1	1	1	1	1	1	P227171X01	
326	R61 A43 287	Sensor cover	EVA,16D	2	2	2	2	2	2	P227172X01	
327	R61 F14 413	Check joint		2	2	2	2	2	2	P639131X01	
328	R61 F14 514	Packing	T/# 1991-NF	1	1	1	1	1	1	P321009X01	
329	R61 Y08 262	Belt heater	240V 45W,<CH1>	1	1	1	1	1	1	P493642X02	
330	R61 F14 410	Ball valve	1/2	1	1	1	1	1	1	P636220X02	
331	R61 Y11 410	Ball valve	1flange	1	1	1	1	1	1	P636311X01	
332	R61 G48 401	Linear expansion valve	DKV18	2	2	2	2	2	2	P632342X01	
333	R61 A45 401	Linear expansion valve coil	<LEV1>	1	1	1	1	1	1	P472017X01	
334	R61 A45 402	Linear expansion valve coil	<SLEV>	1	1	1	1	1	1	P472016X01	
335	R61 155 454	Strainer	6.35D	2	2	2	5	5	5	W882822G01	
336	R61 A42 454	Strainer	9.52D	4	4	4	4	4	4	W882823G01	
337	R61 Y02 454	Strainer		1	1	1	1	1	1	W858399G02	
338	R61 M57 405	Dryer		1	1	1	1	1	1	P641114X01	
339	R61 Y01 850	Insulator		1	1	1	1	1	1	W628447H02	
340	R61 Y02 850	Insulator		1	1	1	1	1	1	W861746H02	
341	R69 963 478	Scroll compressor	HEV92FA1-YB,<MC>	1	1	1	1	1	1	EP10013G08	

PUD-P250YMF-C (-BS,-BF)  
 PUY-P200,P250YMF-C (-BS,-BF)  
 PUHY-P200,P250YMF-C (-BS,-BF)

CONTROL BOX PARTS

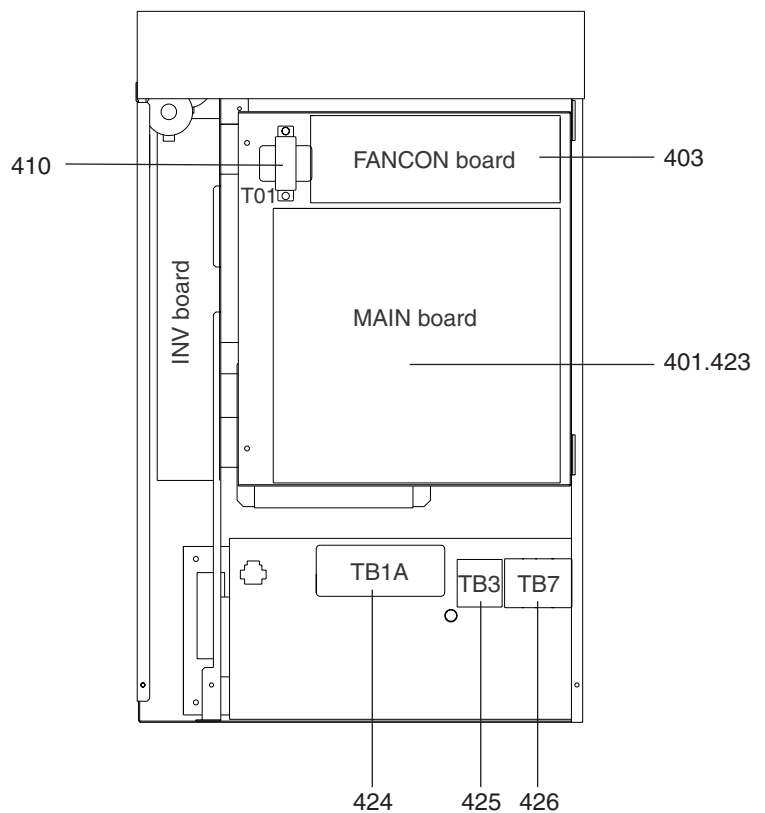
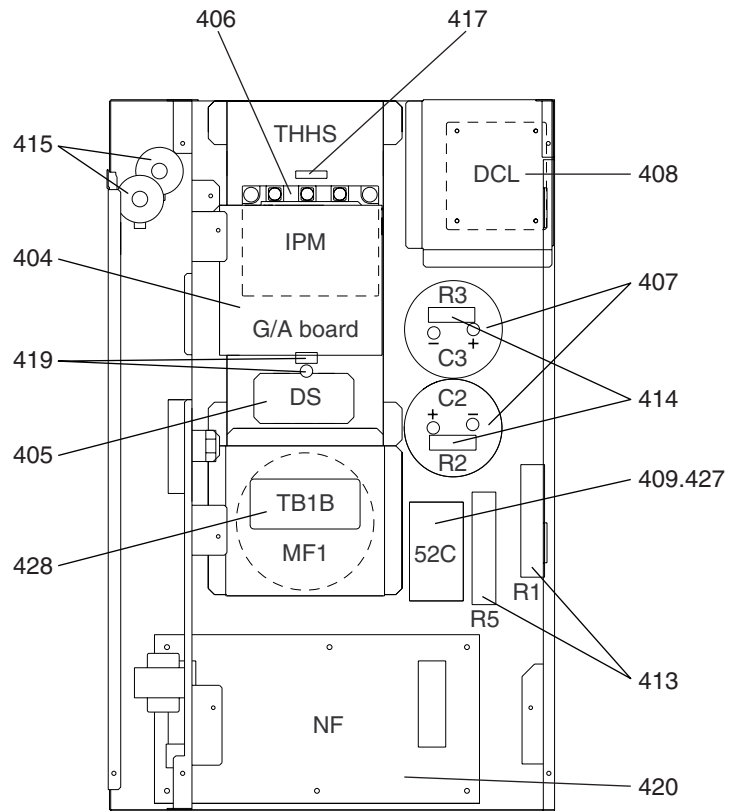
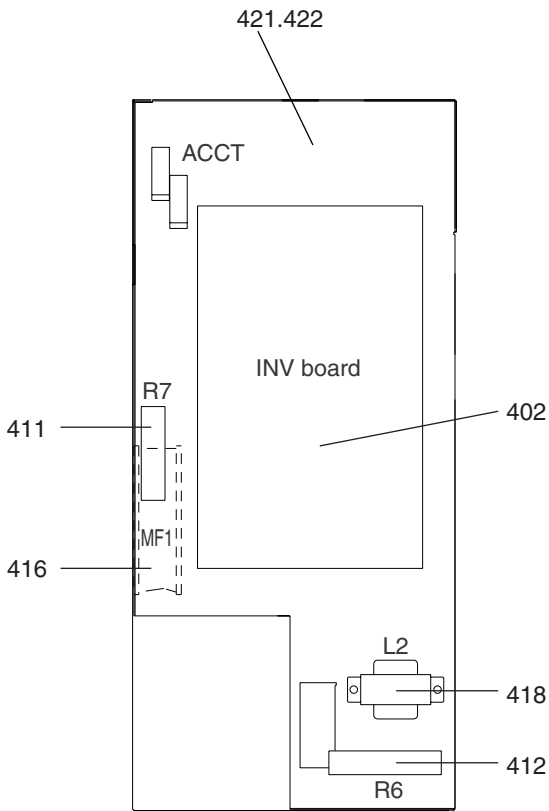



PUD-P250YMF-C (-BS,-BF)  
 PUY-P200,P250YMF-C (-BS,-BF)  
 PUHY-P200,P250YMF-C (-BS,-BF)

CONTROL BOX PARTS

No.	Part No.	Part Name	Spec.											Dwg. No.	Price		
				PUD-P250YMF-C	PUD-P250YMF-C-BS	PUD-P250YMF-C-BF	PUHY-P200YMF-C	PUHY-P250YMF-C	PUHY-P200YMF-C-BS	PUHY-P250YMF-C-BS	PUHY-P200YMF-C-BF	PUHY-P250YMF-C-BF					
401	R61 Y82 280	Main board					1	1	1	1	1	1	1	1	1	W266235G14	
402	R61 Y67 280	INV board		1	1	1	1	1	1	1	1	1	1	1	1	W639915G01	
403	R61 Y65 280	Fan controller board		1	1	1	1	1	1	1	1	1	1	1	1	W639913G01	
404	R61 Y66 280	G/A board		1	1	1	1	1	1	1	1	1	1	1	1	W639914G01	
405	R61 Y12 320	Diode	DF60LB160	1	1	1	1	1	1	1	1	1	1	1	1	W876941G06	
406	R61 Y04 249	IPM	6MBP50RA120	1	1	1	1	1	1	1	1	1	1	1	1	W848413G10	
407	R61 Y18 252	Capacitor	400WV,4700µF<C2,3>	2	2	2	2	2	2	2	2	2	2	2	2	P412265X01	
408	R61 Y01 259	Reactor	1.92mH/34A<DCL>	1	1	1	1	1	1	1	1	1	1	1	1	P419149X01	
409	R61 Y01 619	Magnet contactor (*1)	S-K18<52C>				1	1	1	1	1	1	1	1	1	W647828G01	
410	R61 Y14 260	Transformer	240V/40V<T1>	1	1	1	1	1	1	1	1	1	1	1	1	P715302X01	
411	R61 670 234	Resistor	30W,22Ω<R7>	1	1	1	1	1	1	1	1	1	1	1	1	P411113X01	
412	R61 E69 234	Resistor	40W,110Ω<R6>	1	1	1	1	1	1	1	1	1	1	1	1	P411131X01	
413	R61 Y05 234	Resistor	40W,5kΩ<R1,5>	2	2	2	2	2	2	2	2	2	2	2	2	P411133X01	
414	R61 Y02 234	Resistor	10W,33kΩ,pitch=32<R2,3>	2	2	2	2	2	2	2	2	2	2	2	2	P411126X01	
415	R61 Y02 249	ACCT	DJ-6	1	1	1	1	1	1	1	1	1	1	1	1	W639917G01	
416	R61 Y15 118	Fan	109S25UL	1	1	1	1	1	1	1	1	1	1	1	1	W639916G01	
417	R61 F14 201	Thermistor		1	1	1	1	1	1	1	1	1	1	1	1	P414095X01	
418	R61 Y02 244	Choke coil	1A,30mH	1	1	1	1	1	1	1	1	1	1	1	1	P419121X01	
419	R61 L85 252	ZNR+C		1	1	1	1	1	1	1	1	1	1	1	1	W886345G01	
420	R61 Y08 293	NF VF4030C-MX2		1	1	1	1	1	1	1	1	1	1	1	1	P419147X01	
421	R61 Y19 281	Control box					1	1	1	1	1	1	1	1	1	W266294G06	
422	R61 Y27 305	Control box		1	1	1										W266294G09	
423	R61 Y51 281	Main board		1	1	1										W657945G01	
424	R61 Y05 246	Terminal bed	TB1A	1	1	1	1	1	1	1	1	1	1	1	1	P436151X01	
425	R61 435 246	Terminal bed	TB3	1	1	1	1	1	1	1	1	1	1	1	1	A73S950H02	
426	R61 979 247	Terminal bed	TB7	1	1	1	1	1	1	1	1	1	1	1	1	P436110X01	
427	R61 Y28 225	Magnet contactor (*1)	PAK-21J<52C>	1	1	1	1	1	1	1	1	1	1	1	1	S427020H12	
428	R61 Y07 246	Terminal bed	TB1B	1	1	1	1	1	1	1	1	1	1	1	1	P436229X01	

(\*1) Confirm the type of the magnet contactor in the box.  
 Order magnet contactor No.409 if the parts is S-N18, and order magnet contactor No.427 if the parts type is PAK-21J.

PUD-P250YMF-C (-BS,-BF)  
 PUY-P200,P250YMF-C (-BS,-BF)  
 PUHY-P200,P250YMF-C (-BS,-BF)

BLOWER PARTS

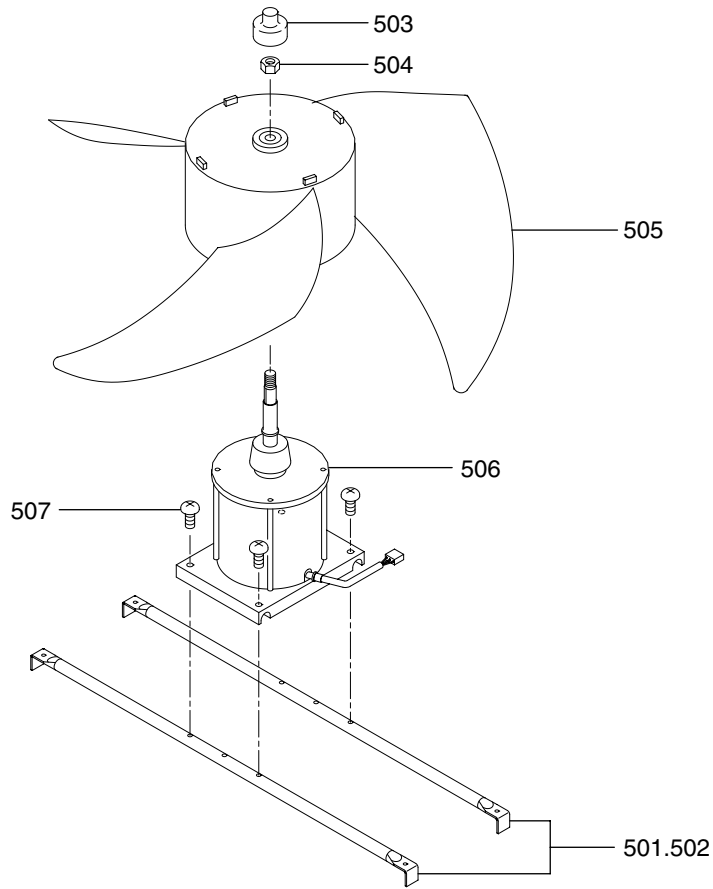

No.	Part No.	Part Name	Spec.									Dwg. No.	Price		
				PUD-P250YMF-C	PUD-P250YMF-C-BS	PUD-P250YMF-C-BF	PUHY-P200YMF-C	PUHY-P250YMF-C	PUHY-P200YMF-C-BS	PUHY-P250YMF-C-BS	PUHY-P200YMF-C-BF			PUHY-P250YMF-C-BF	
501	R61 A42 140	Fan stand		2		2	2	2				2	2	W856127G05	
502	R61 A43 140	Fan stand			2				2	2				W856127G06	
503	R61 A69 086	Cap		1	1	1	1	1	1	1	1	1	1	P221056X01	
504	R61 A42 122	Nut 16		1	1	1	1	1	1	1	1	1	1	P541016X01	
505	R61 E66 115	Propeller fan	750D	1	1	1	1	1	1	1	1	1	1	W872619G01	
506	R61 Y33 221	Motor	YD380VB<MF>	1	1	1	1	1	1	1	1	1	1	P714762X01	
507	R61 E90 087	Screw	6X14	4	4	4	4	4	4	4	4	4	4	P521020X01	

