CONTENTS

1. Specifications	1
1-1 Main Features	1
1-2 List of Possible Combinations of Indoor and Outdoor Units	2
1-3 Unit Specifications	2
2. Capacity Curves	4
2-1 Cooling Capacity	4
2-2 Cooling Input	4
2-3 SHF Curves	5
2-4 Correction by refrigerant piping length	6
2-5 Operation limit	6
3. Sound Levels	7
3-1 Noise Level	7
3-2 NC Curves	8
3-3 Fan Characteristics Curves	8
4. External Dimensions	9
5. Electrical Wiring Diagrams	12
6. Options	15
7. Refrigerant Circuit Diagram And Thermal Sensor	16
8. System Design	17
8-1 Piping	17
8-2 Control Wiring	18
8-3 Types of switch settings and setting methods	18
8-4 Wiring and Address Setting (System Using MA Remote Controller)	20
8-5 External input/output specifications	32
9. Air Conditioning the Computer Room	34
9-1 Main Features of the Floor-Duct Air Conditioners	34
9-2 Major Characteristics of Computer Room Air Conditioners	34
9-3 Step-by-Step Plan for the Implementation of the Air-Conditioning	35
9-4 Conditions for the Installation of Computer-Room Air Conditioners	36
9-5 Setting the Air conditioners	37
9-6 Automatic Control of the Computer Room	39
10. Maintenance/Inspection	40
10-1 Maintenance/Inspection Schedule	40

1. Specifications

1-1. Main Features

(1) List of Models

PUD-P250YMF-C } Outdoor Unit

10HP(Down flow): PFD-P250VM-A(-H)
 20HP(Down flow): PFD-P500VM-A(-H) } Indoor Unit

- * 'H' in the indoor units indicates that the unit pipes come out of the top of the unit (50/60Hz, fit to order).
- * PFD-type indoor units cannot be connected to outdoor units other than the ones specified above.
- * PFD-type indoor units and other types of indoor units cannot coexist in the same refrigerant system.

<10HP System>

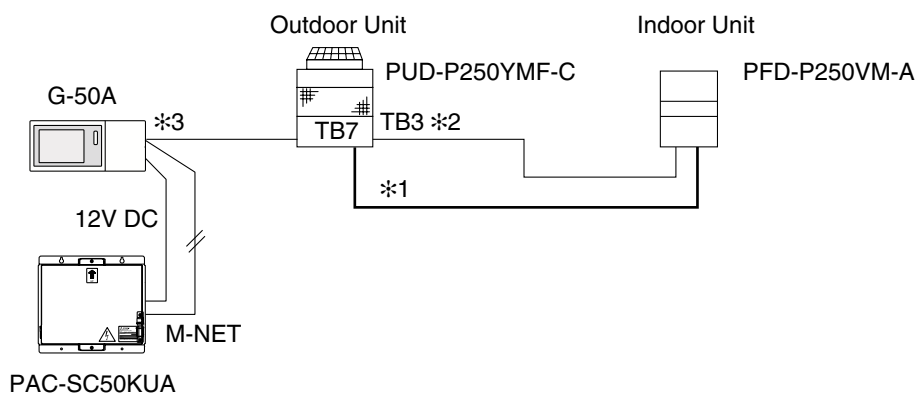

When using a PFD-P250VM-A as an indoor unit, connect an outdoor unit PUD-P250YMF-C to each indoor unit and operate with a built-in remote control for the indoor unit.

- *1: Bold line indicates refrigerant piping (gas/liquid). This system consists of one refrigerant circuit.
- *2: Indicates TB3-type transmission line that connects the indoor and outdoor units. This system consists of 1 refrigerant circuit.
- *3: Indicates TB7-Type transmission line that allows the unit to communicate with the controller.

<20HP System>

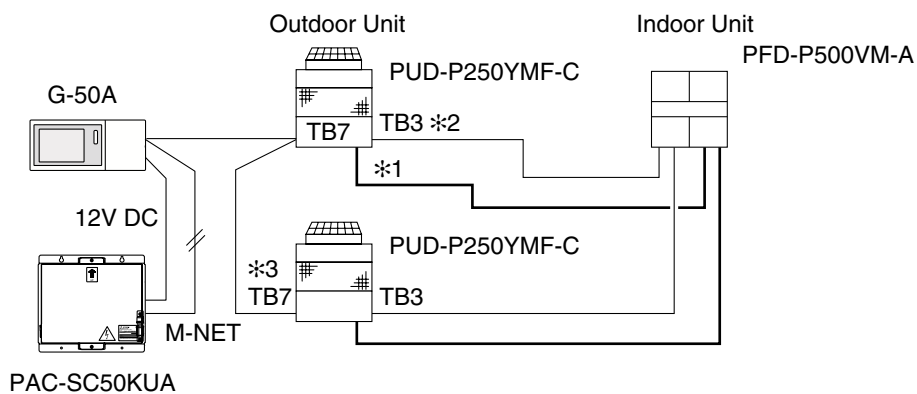

When using a PFD-P500VM-A as an indoor unit, connect 2 PUD-P250YMF-C outdoor units to each indoor unit and operate with a built-in remote control for the indoor unit.

- *1: Bold line indicates refrigerant piping (gas/liquid). This system consists of 2 refrigerant circuits.
- *2: Indicates TB3-type transmission line that connects the indoor and outdoor units. This system consists of 2 refrigerant circuits.
- *3: Indicates TB7-type transmission line that allows the unit to communicate with the controller.

1-2. List of Possible Combinations of Indoor and Outdoor Units

Units					Indoor Units		
Model Name					Down-flow Type		
Power Source					380-415V(50Hz) 400,415V(60Hz)	380-415V(50Hz) 400,415V(60Hz)	
Unit Horse Power					10HP	20HP	
Series Name					PFD-P250VM-A(-H)	PFD-P500VM-A(-H)	
Outdoor Units	Air-cooling	380 /400 /415V	10HP	PUD- P250YMF-C	Q	28.0	56.0
					W	10.9	21.8
					A	18.3/17.3/16.3	36.1/34.3/33.0
					Power factor	90	91

*1: Refer to the following pages for detailed specifications of each unit.

*2: The values in the chart are as follows: Q, Total Capacity [kW]; W, Total Input [kW]; A, Total Electrical Current [A]; Power Factor [%]. They were measured at operation under the following conditions: Indoor Intake Temperature: 27°CDB/19°CWB, Outdoor Intake Temperature 35°CDB with 7.5m of refrigerant piping.

1-3. Unit Specifications

(1) Outdoor Unit

			PUD-P250YMF-C
Capacity	* 1	kW	28.0
Power source			3N ~ 380/400/415V 50/60Hz
Power input		kW	8.4
Current		A	14.0/13.3/12.8
Fan	Type × Quantity		Propeller fan
	Airflow rate	m³/min	185
	Motor output	kW	0.38
Compressor	Type		Hermetic
	Motor output	kW	7.5
	Crankcase heater	kW	0.045 (240V)
Starting current		A	12
Refrigerant / Lubricant			R407C/MEL32
External finish			Steel plate painting with polyester powder <MUNSELL 5Y8/1 or similar>
External dimension		mm	1715(H)×990(W)×840(L)
Protection devices	High pressure protection		2.94MPa
	Compressor / Fan		Over current protection / Thermal switch
	Inverter		DC bus current protection, thermal switch
Refrigerant piping diameter	Liquid / Gas		φ12.7 flare / φ28.58 Flange
Noise level	* 2	dB(A)	56
Net weight		kg	231
Operating temperature range			Indoor:12°CWB ~ 24°CWB Outdoor:-15°CDB ~ 43°CDB (0°CDB ~ 43°CDB with outdoorunit at lower position)

Note: Cooling capacity indicates the maximum value at operation under the following condition.

*1 Indoor 27°CDB/19°CWB, Outdoor 35°CDB

Pipe length 7.5m, Height difference 0m

*2 It is measured in anechoic room.

(2) Indoor Unit

			PFD-P250VM-A	PFD-P500VM-A
Power source			3N~380-415V 50Hz / 3N~400-415V 60Hz	
Cooling capacity	*: 1	kW	28.0	56.0
Power consumption		kW	2.5	5.0
Current		A	5.5/5.3/5.1	9.5/9.0/8.7
External finish			<5Y 7/1>	
Dimensions	Height	mm	1895	
	Width	mm	1,200	1,800
	Depth	mm	800	
Net weight		kg	350	480
Heat exchanger			Cross fin (Aluminum-plate fin and copper tube)	
Fan	Type		Sirocco fan	Sirocco fan X 2
	Airflow rate	m ³ /min	160	320
	External static pressure	Pa	120	
Motor	Type		3 phases induction motor	
	Output	kW	3.7	5.5
Starting current		A	60	75
Air filter			PP Honeycomb fabric	
Refrigerant pipe dimension	Gas (Flare)	mm	ø 28.58	ø 28.58 X 2
	Liquid (Flare)	mm	ø 12.7	ø 12.7 X 2
Drain pipe dimension			Rp1	
Noise level (Lo-Mid2-Mid1-Hi)	*: 2	dB(A)	59	64

Note: *:1 Cooling capacity indicates the maximum value at operation under the following conditions;
Indoor 27°CDB/19°CWB, Outdoor 35°CDB

*:2 Measured in an anechoic room.

2. Capacity Curves

2-1. Cooling Capacity

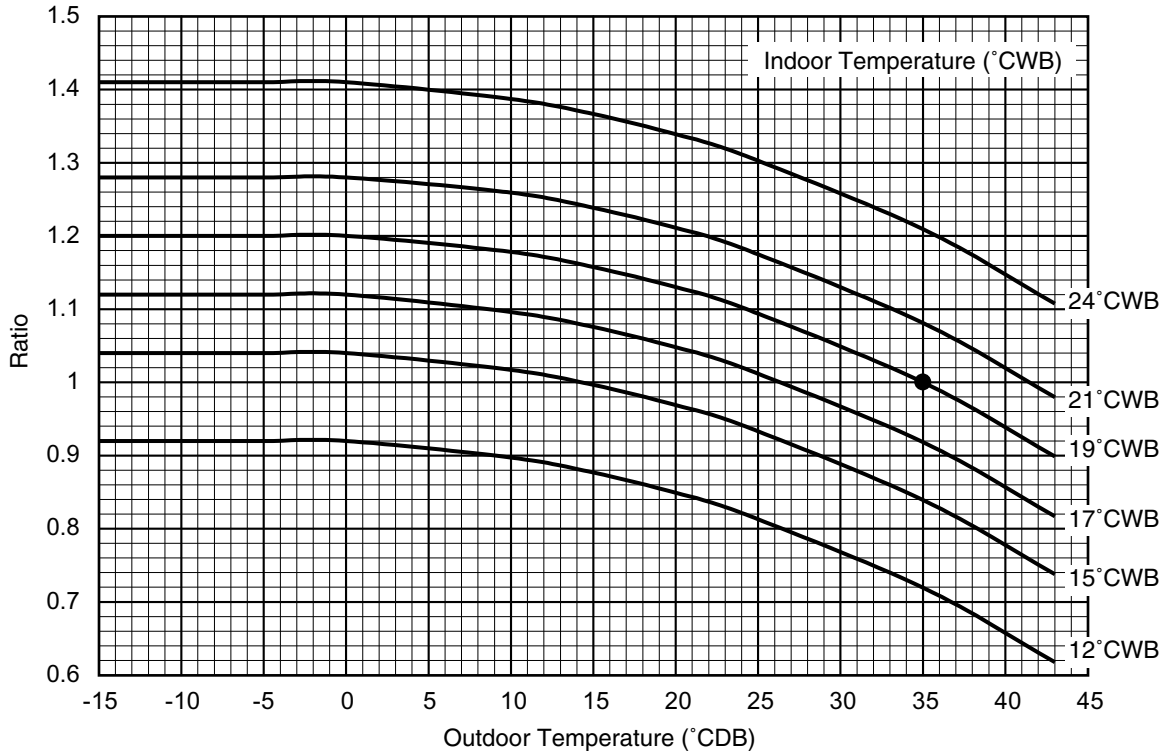

2-2. Cooling Input

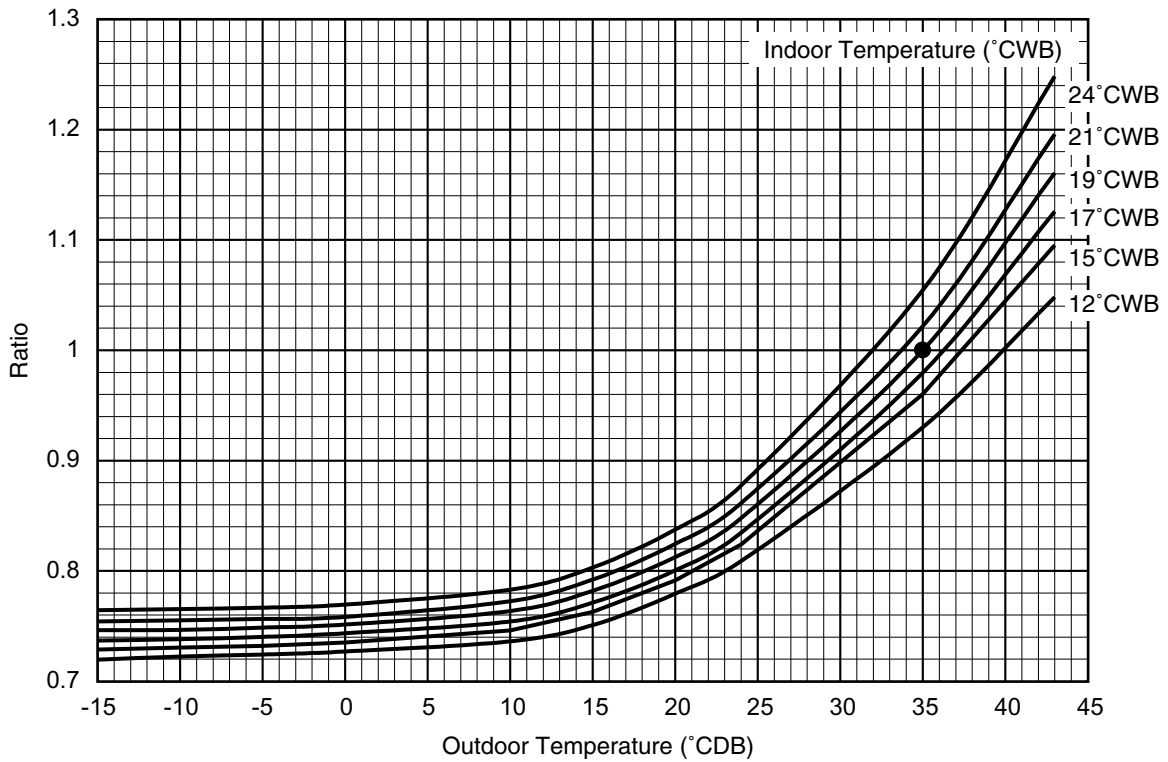

- * The correction curves indicate the values measured at the point where the compressor was operated at its maximum capacity.
- * ● indicates the standard value.

2-3. SHF Curves

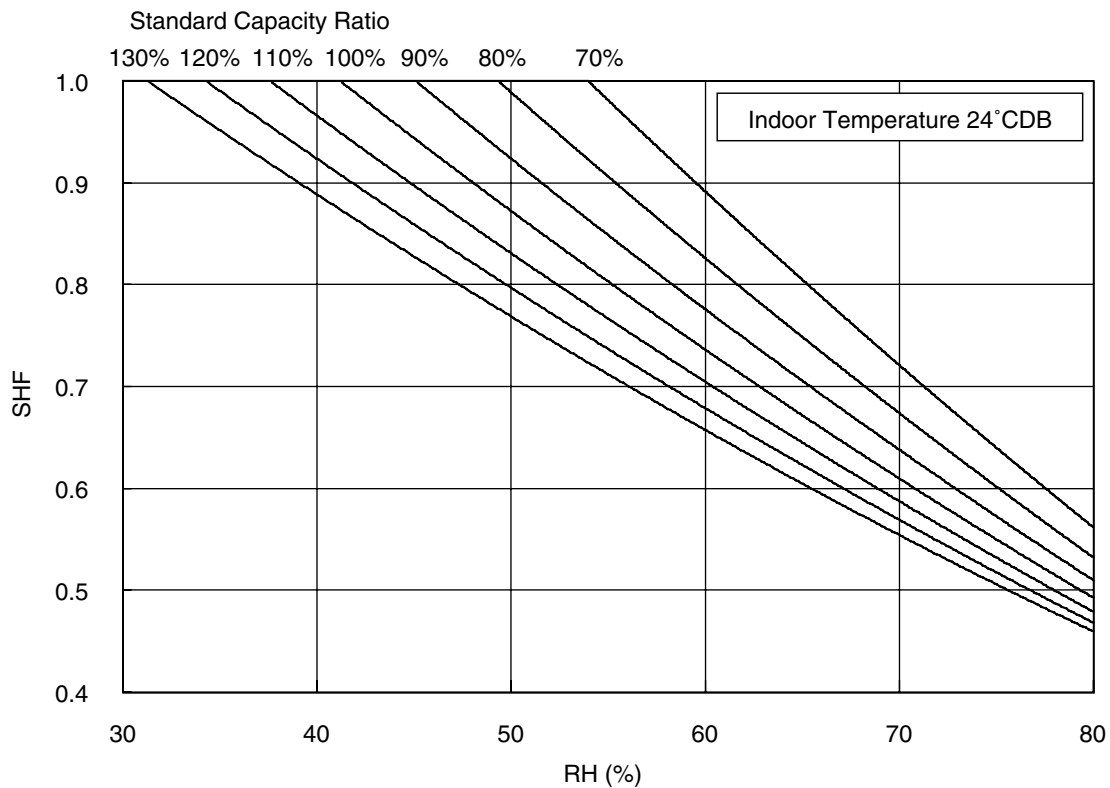
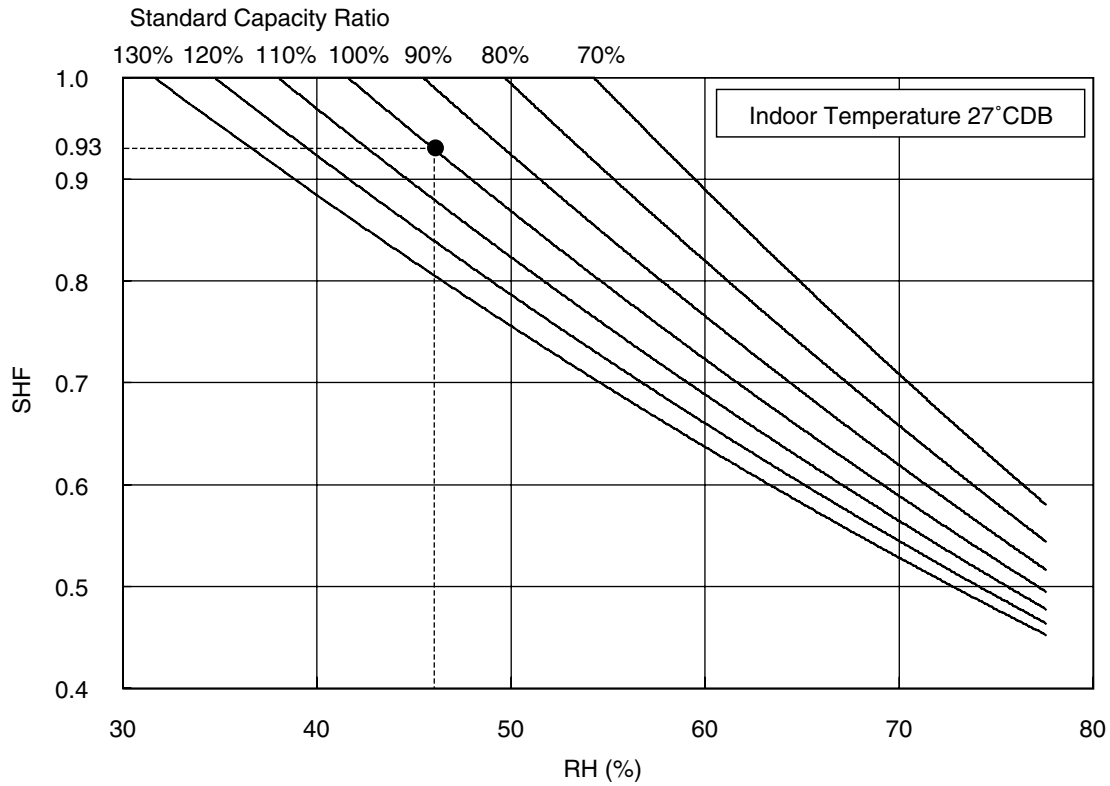

Operation Temperature Range: Indoor : 12°CWB~24°CWB
 Outdoor: -5°CDB~43°CDB
 (RH : 30~80%)
 Standard Point "●" : Indoor : 27°CDB/19°CWB
 Outdoor: 35°CDB/-

2-4. Correction by refrigerant piping length

To obtain a decrease in cooling/heating capacity due to refrigerant piping extension, multiply by the capacity correction factor based on the refrigerant piping equivalent length in the table below.

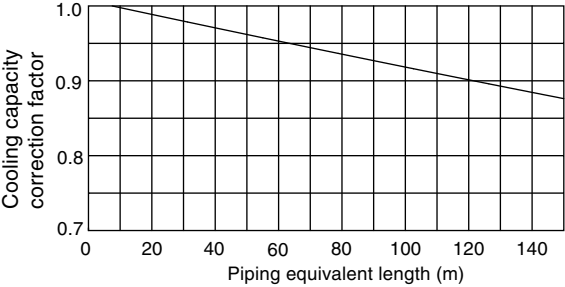

- How to obtain piping equivalent length
Equivalent length = (Actual piping length to the farthest indoor unit) + (0.50 × number of bent on the piping)m

2-5. Operation limit

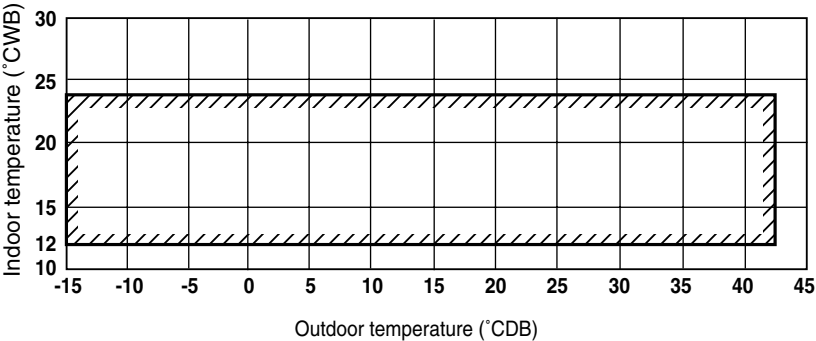

(Outdoor door temperature :0°CDB~43°CDB with outdoor unit at lower position in cooling mode.)

3. Sound Levels

3-1. Noise Level

(1) Outdoor Unit

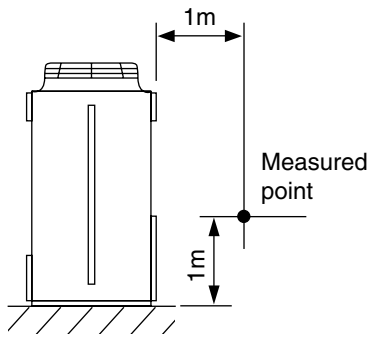

Series	Noise Level (dB [Type A])
PUD-P250YMF-C	56

(2) Indoor Unit

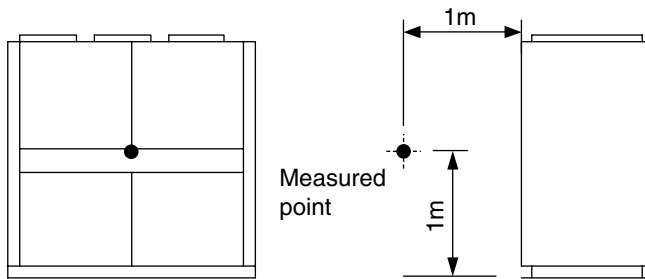

Series	Noise Level (dB [Type A])
PFD-P250VM-A	59
PFD-P500VM-A	64

3-2. NC Curves

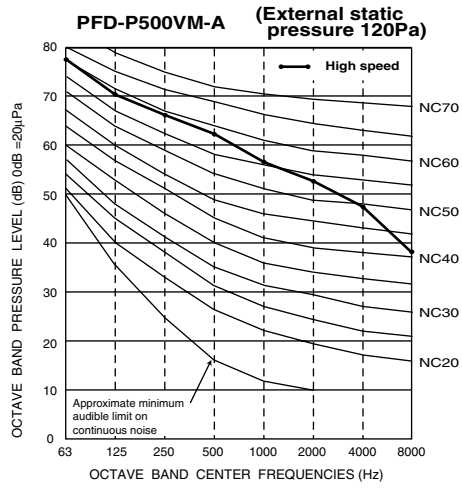
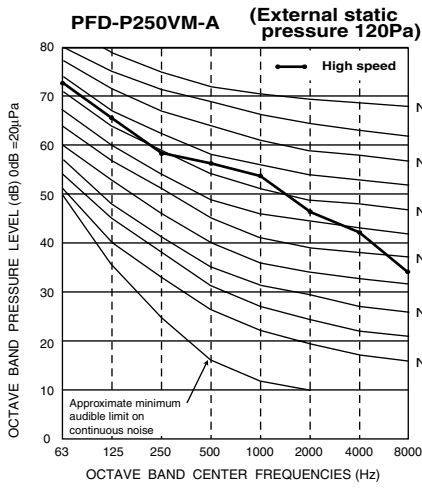
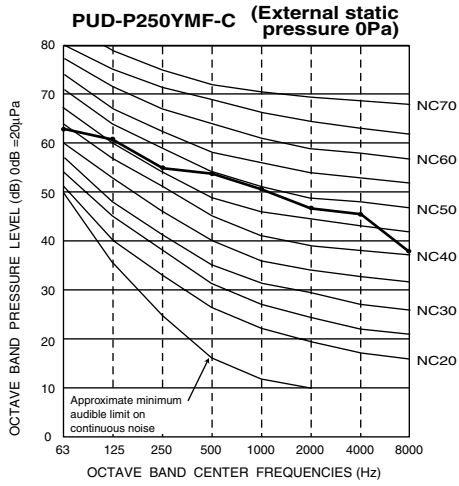

3-3. Fan Characteristics Curves

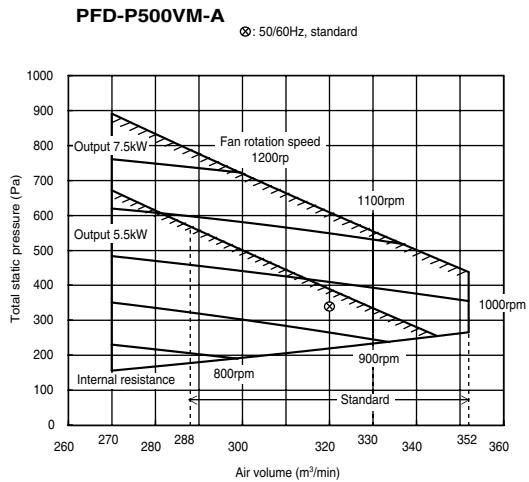
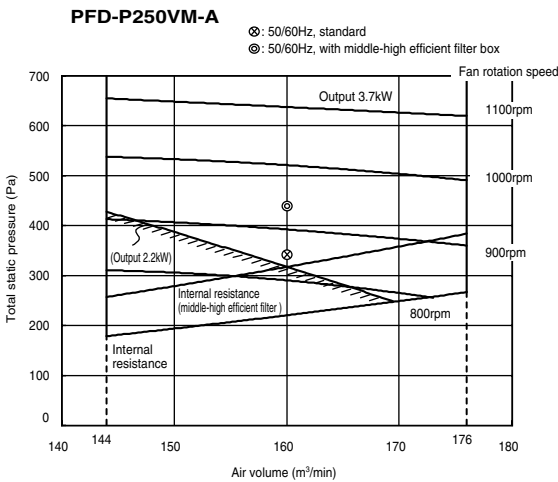

4. External Dimensions

PUD-P250YMF-C

Unit : mm

- < Accessory >
- Refrigerant (gas) conn. pipe 1 pc.
(The connecting pipe is fixed with the unit)
 - Packing for conn. pipe 1 pc.
(Attached near the ball valve)
 - Wiring mounting board
 - Conduit mounting plate
(Painted the same color as the unit body)
 - $\phi 40$ 1 pc.
 - $\phi 33$ 1 pc.
 - $\phi 27$ 1 pc.
 - Tapping screw 4 X 10 6 pos.

Note.1 Please leave a space under the outdoor unit for the piping. When you connect the piping from the bottom.
(Please be careful not to close the hole of the bottom plate by the basement)

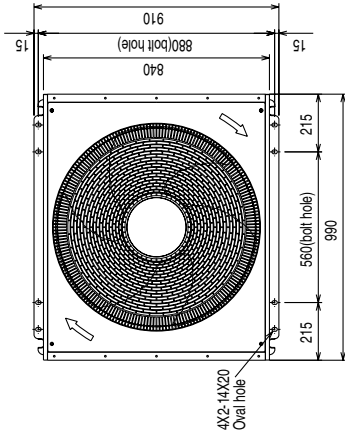

Plane view

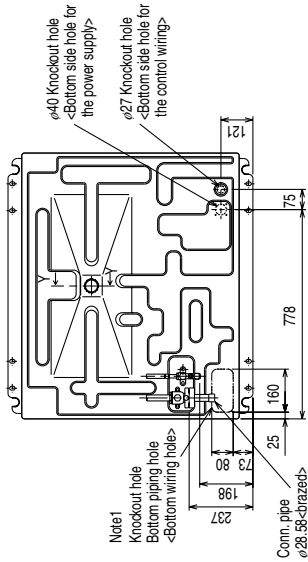

Cross section X-X

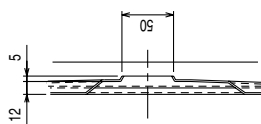

Cross section Y-Y

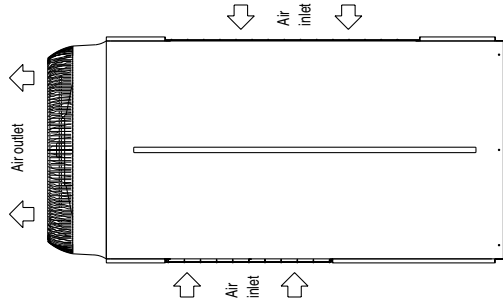

Right side view

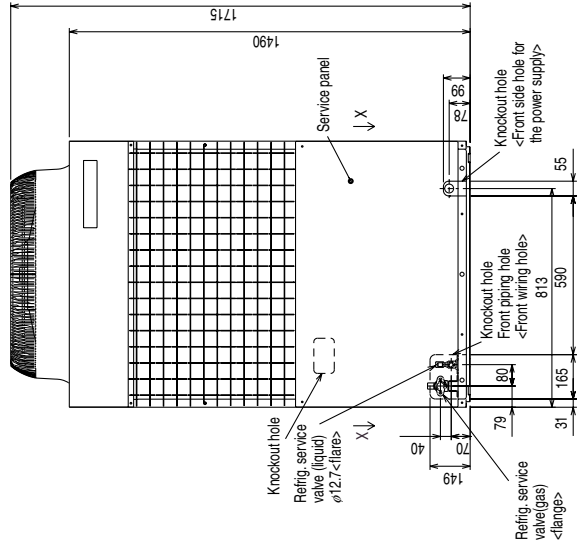

Front view

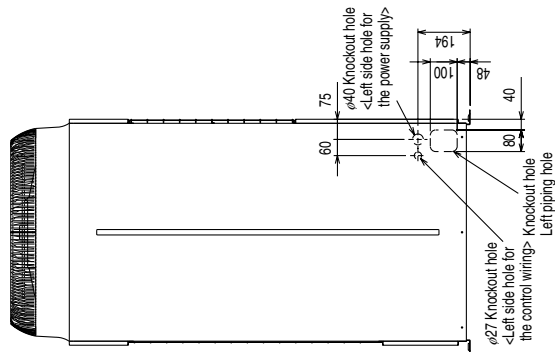

Left side view

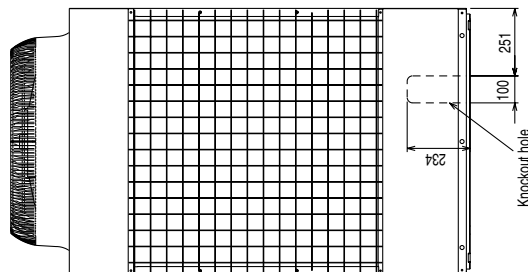

Rear view

PFD-P250VM-A

Unit : mm

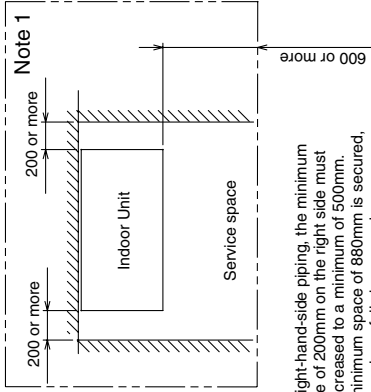

Note1. For right-hand-side piping, the minimum space of 200mm on the right side must be increased to a minimum of 500mm.
 Note2. If a minimum space of 880mm is secured, the panel can fully be opened.

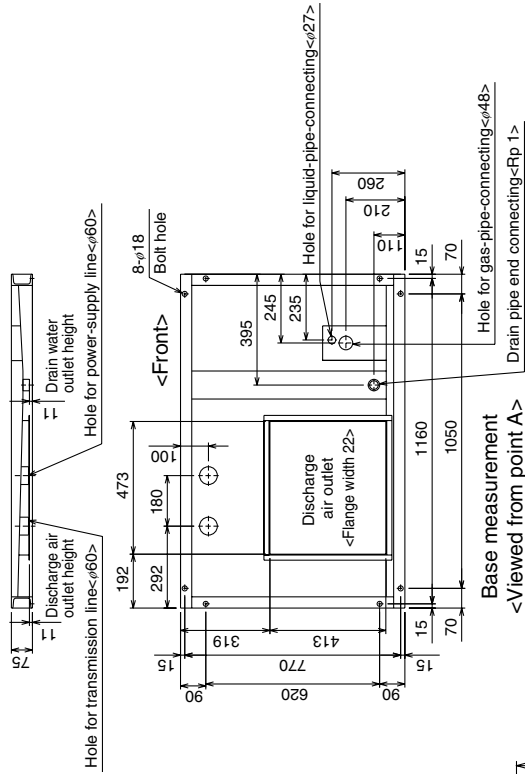
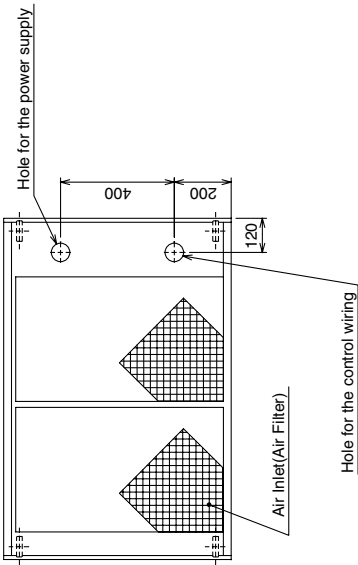

- < Accessories >
- Lifting bolts4pcs.
 - Refrigerant (gas) conn. pipe (φ 28.58 < brazed >)1pc.
 - Packing for flange1pc.
 - Insulation cover for flange1pc.
 - Flare nut (liquid)1pc.
 - Hexagonal allen key1pc.
- (for front panel opening/closing)

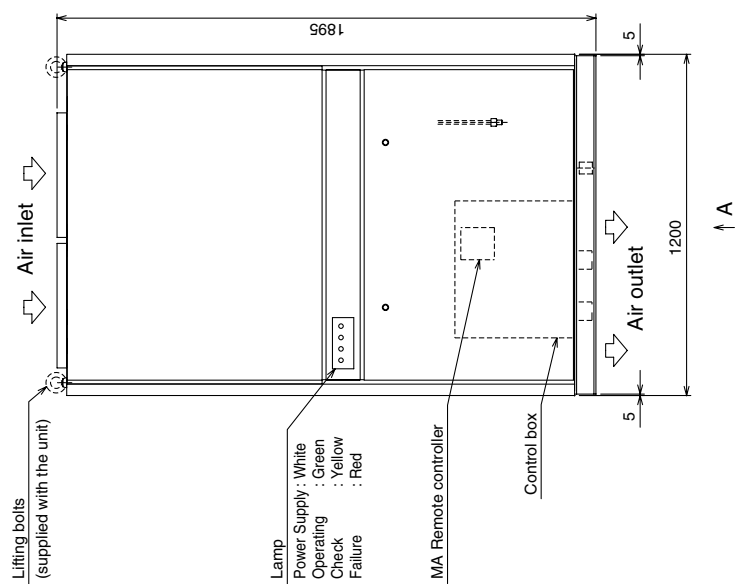

5. Electrical Wiring Diagrams

PUD-P250YMF-C

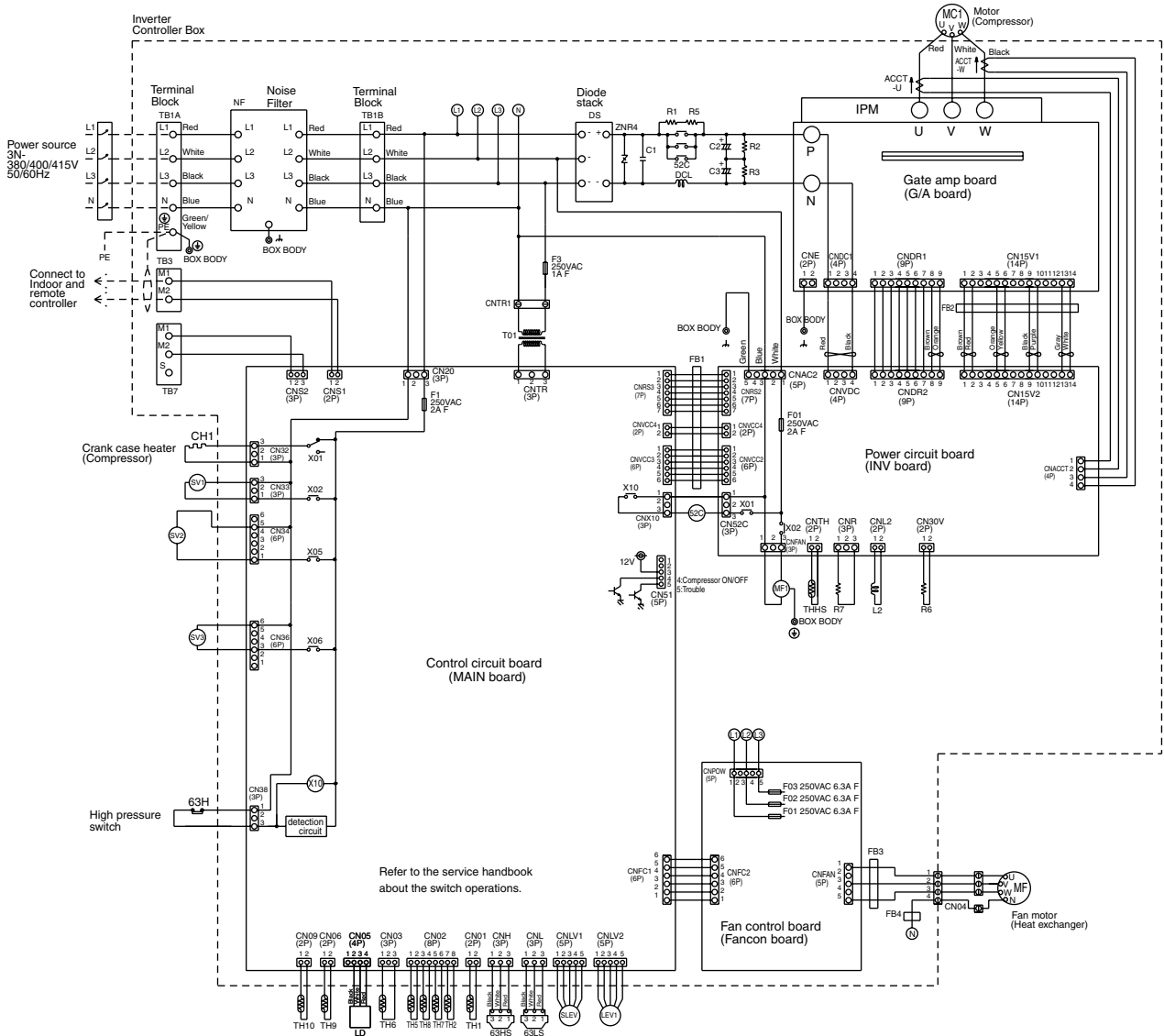

<SYMBOL EXPLANATION>

Symbol	N a m e	Symbol	N a m e	Symbol	N a m e	Symbol	N a m e
DCL	DC reactor (Power factor improvement)	LEV1	Electronic expansion valve (Sub-cool coil bypass)	TH2	Thermistor Saturation evapo. temp. detect	TH10	Compressor shell temp.
ACCT-U,W	Current Sensor	SLEV	Electronic expansion valve(Oil return)	TH5	Pipe temp. detect	THHS	Radiator panel temp. detect
ZNR4	Varistor	63HS	High pressure sensor	TH6	OA temp. detect	X1-10	Aux. relay
52C	Magnetic contactor (Inverter main circuit)	63LS	Low pressure sensor	TH7	liquid outlet temp. detect at Sub-cool coil	FB1-4	Ferrite core
MF1	Fan motor (Radiator panel)	L2	Choke coil(Transmission)	TH8	bypass outlet temp. detect at Sub-cool coil	⊕	Earth terminal
SV1,SV2	Solenoid valve (Discharge-suction bypass)	IPM	Intelligent power module	TH9	High pressure liquid. temp.		
SV3	Solenoid valve (Heat exchanger capacity control)	TH1	Thermistor Discharge pipe temp. detect				

PFD-P250VM-A

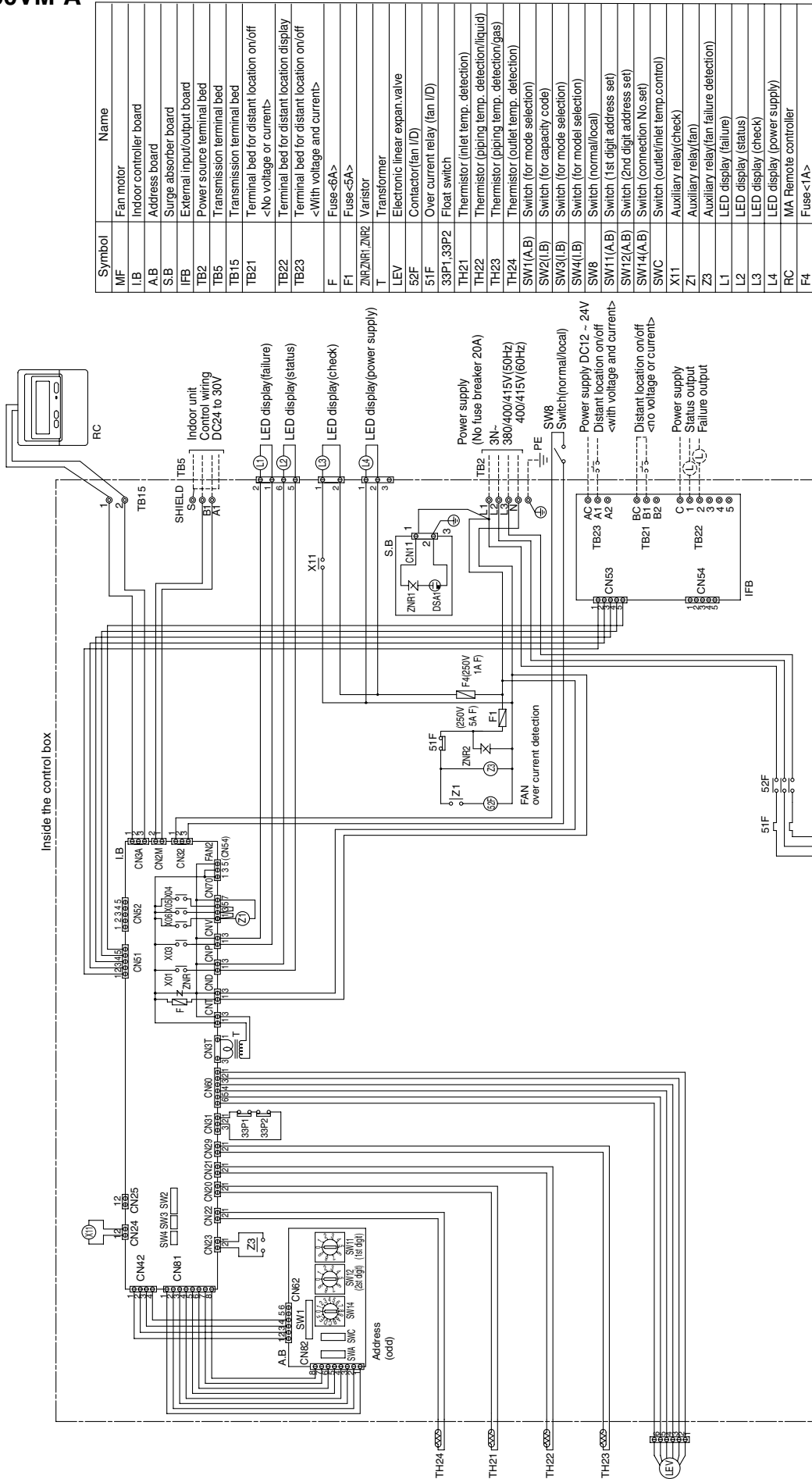

- Note:
1. The dotted lines show field wiring.
 2. Always use odd numbers for the indoor unit address.
 3. Connect the transmission line from indoor unit to outdoor unit whose address equals the address of the connected indoor unit + 50.
 4. Conventions: ⊙ terminal bed; ⊕ connector; ⊞ board-insertion connector or fastening connector of control board.

PFD-P500VM-A

Symbol	Name
MF	Fan motor
LB1, LB2	Indoor controller board
A.B1, A.B2	Address board
S.B	Surge absorber board
IFB	External input/output board
TB2	Power source terminal bed
TB5-1, -2	Transmission terminal bed
TB15	Transmission terminal bed
TB21	Terminal bed for distant location on/off <No voltage or current >
TB22	Terminal bed for distant location display
TB23	Terminal bed for distant location on/off <With voltage and current >
F	Fuse<6A>
F1	Fuse<5A>
F4	Fuse<1A>
ZMR, ZNR1, ZNR2	Varistor
T	Transformer
LEV1, 2	Electronic linear expans. valve
52F	Contact(fan I/D)
51F	Over current relay (fan I/D)
3P1-1, 2, 3P2-1, 2	Float switch
TH21-1, TH21-2	Thermistor (inlet temp. detection)
TH22-1, TH22-2	Thermistor (pipng temp. detection)(liquid)
TH23-1, TH23-2	Thermistor (pipng temp. detection)(gas)
TH24-1, TH24-2	Thermistor (outlet temp. detection)
SW1(A, B)	Switch (for mode selection)
SW2(LB)	Switch (for capacity code)
SW3(LB)	Switch (for mode selection)
SW4(LB)	Switch (for model selection)
SW8	Switch (normal/local)
SW11(A, B)	Switch (1st digit address set)
SW12(A, B)	Switch (2nd digit address set)
SW14(A, B)	Switch (connection No.set)
SWC	Switch (outlet/inlet temp.control)
X11-X12	Auxiliary relay(check)
Z1-Z2	Auxiliary relay(fan)
Z3	Auxiliary relay(fan failure detection)
L1	Lamp display (No.1 failure)
L2	Lamp display (No.2 failure)
L3	Lamp display (status)
L4	Lamp display (check)
L5	Lamp display (power supply)
RC	MA Remote controller

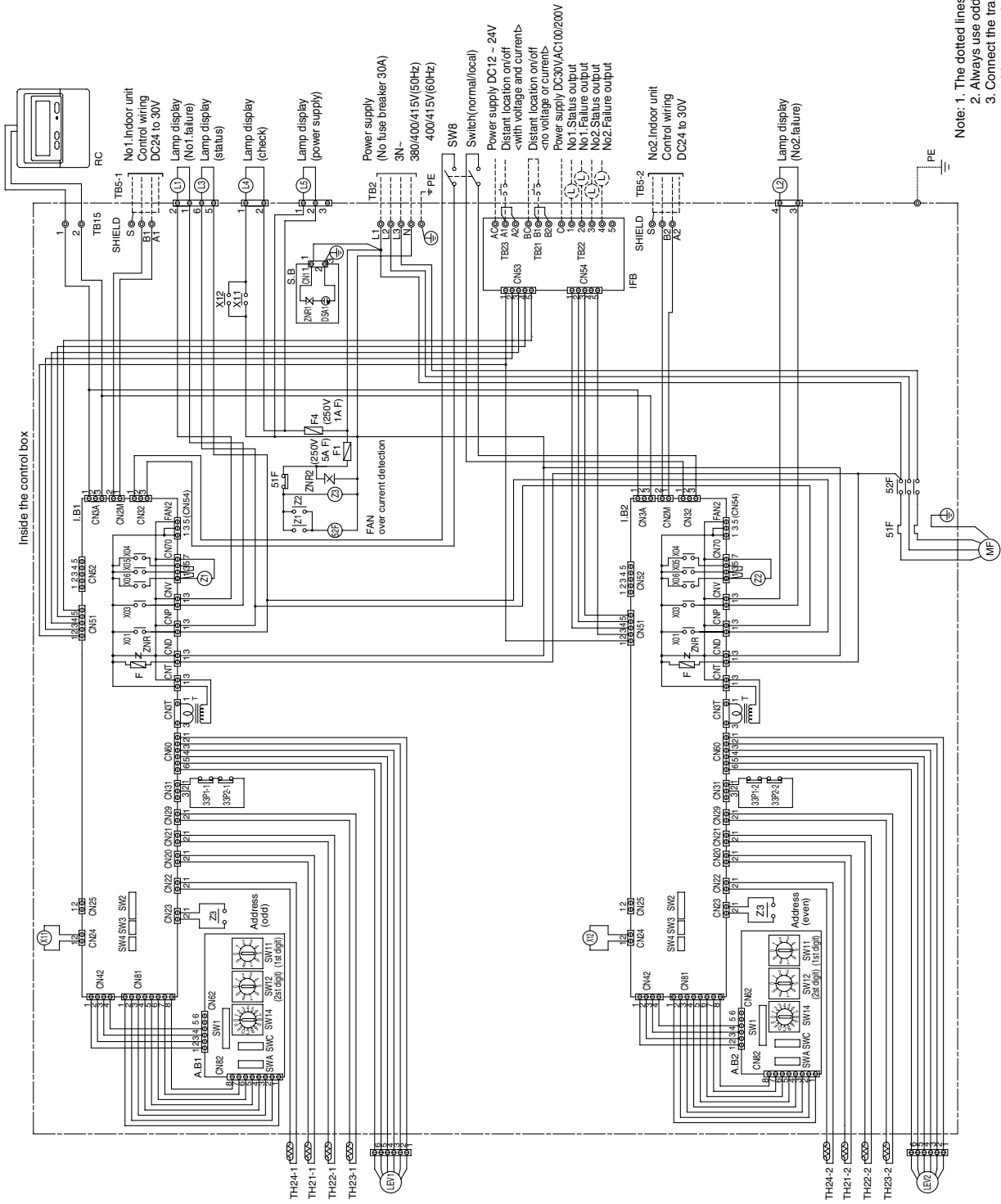

- Note: 1. The dotted lines show field wiring.
 2. Always use odd numbers for the indoor unit address.
 3. Connect the transmission line from indoor unit to outdoor unit whose address equals the address of the connected indoor unit + 50.
 4. Conventions: ⊕: terminal bed, ⊕: connector, ⊕: board-insertion connector or fastening connector of control board.

6. Options

Description	Model	Applicable capacity
Square duct flange (Standard filter)*1	PAC-TS75DFB	P250
	PAC-TS76DFB	P500
Square duct flange (High-efficiency filter)	PAC-TS70TB	P250
	PAC-TS72TB	P500
High-efficiency filter 65% *2	PAC-TS60AF	P250
	PAC-TS62AF	P500
High-efficiency filter 90% *2	PAC-TS65AF	P250
	PAC-TS67AF	P500

*1 Used to connect Intake Duct . Use the filter supplied with the unit.

*2 Requires square duct flange (High-Efficiency Filter).

7. Refrigerant Circuit Diagram And Thermal Sensor

PUD-P250YMF-C

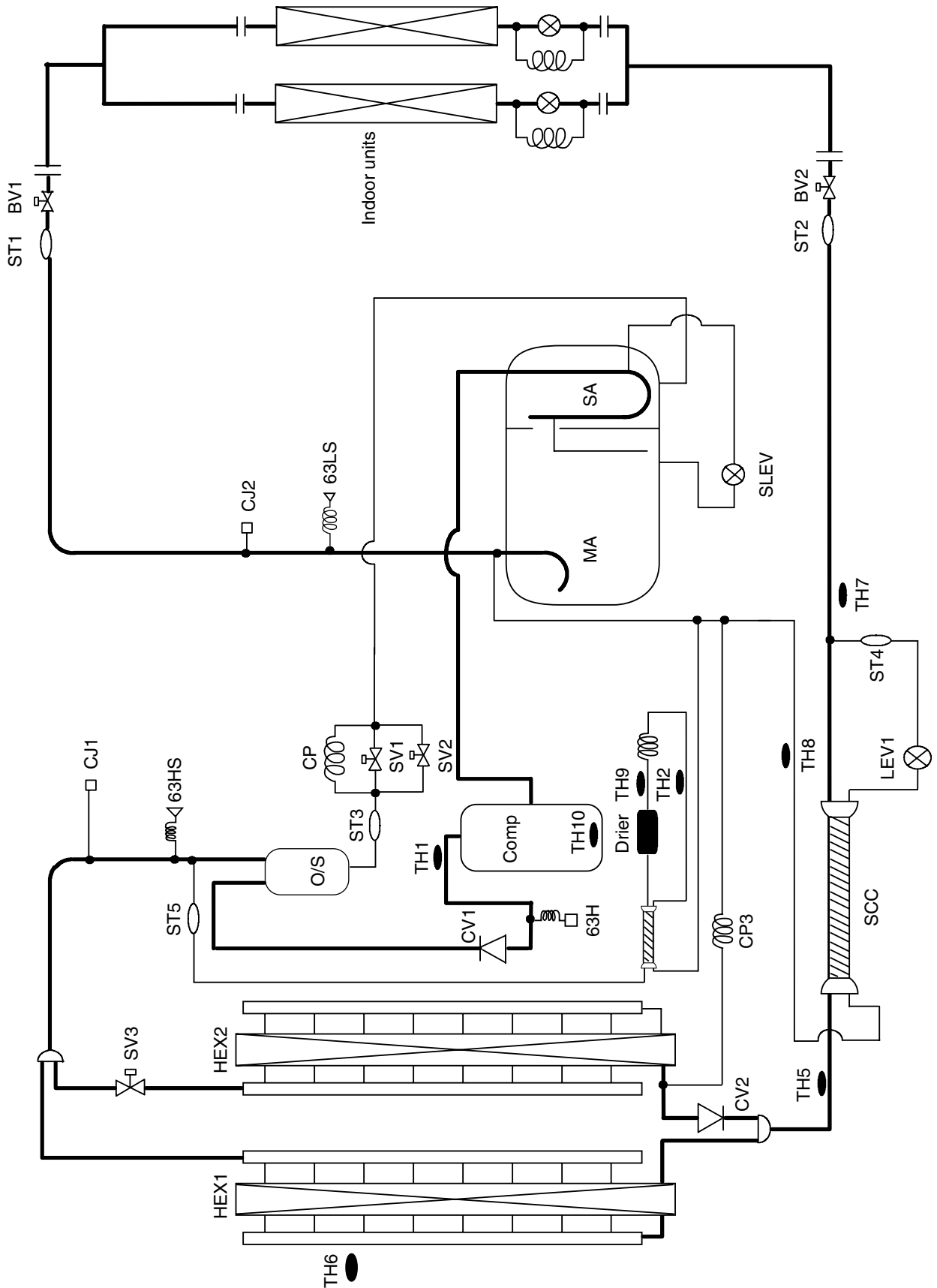

8. System Design

8-1.Piping

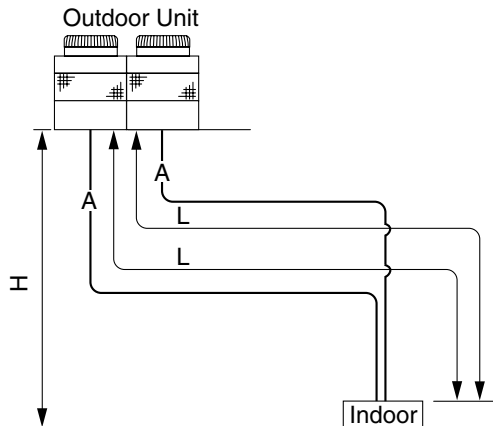
<p>Sample Unit Connection</p>				
<p>Maximum Pipe Length (L)</p>	<p>Net length: under 120m, Total Length: under 150m</p>			
<p>Maximum Height Difference Between Indoor and outdoor units (H)</p>	<p>Under 50m (Under 40m if the outdoor unit is installed below the indoor unit. Under 15m if the outdoor temperature is under 10°C.)</p>			
<p>■ Selecting Refrigerant Pipes</p>	<p>Gas pipe: $\phi 28.58 \times 2$ Liquid pipe: $\phi 12.7 \times 2$</p>			
<p>■ Adding the Refrigerant</p> <p>The outdoor unit is shipped with 8.5 kg of refrigerant. It does not include enough refrigerant for extra piping system. Use additional refrigerant for each refrigerant piping system (2 refrigerant circuits). Record the length of the pipe and the amount of the added refrigerant on the outdoor unit for services in the future.</p> <p>■ Calculating the amount of refrigerant to be added</p> <ul style="list-style-type: none"> · The amount of refrigerant needed for additional piping depends on the diameter and the length of the added liquid pipes. · Calculate the amount to be added as shown on the right, and add the refrigerant in that amount. · Round up the figure under 0.1kg. (e.g. 11.06kg would be 11.1kg). 	<p><The amount of refrigerant to be added></p> <table border="1" data-bbox="702 1249 1356 1422"> <tr> <td style="text-align: center;">Size of the liquid pipe Total length of the pipe with a diameter of $\phi 12.7 \times 0.12$</td> <td rowspan="2" style="vertical-align: middle; padding-left: 10px;">+ 2.0kg</td> </tr> <tr> <td style="text-align: center;">(m) $\times 0.12$ (kg/m)</td> </tr> </table> <p>(i.e.) When using a 120m pipe with a diameter of $\phi 12.7$ $120\text{m} \times 0.12\text{kg/m} + 2.0\text{kg} = 16.4 \text{ kg}$</p>	Size of the liquid pipe Total length of the pipe with a diameter of $\phi 12.7 \times 0.12$	+ 2.0kg	(m) $\times 0.12$ (kg/m)
Size of the liquid pipe Total length of the pipe with a diameter of $\phi 12.7 \times 0.12$	+ 2.0kg			
(m) $\times 0.12$ (kg/m)				

⚠ Caution

Charge Liquid Refrigerant

Filling the equipment with gas refrigerant will result in a power loss due to transformation of refrigerant in the tank.

8-2. Control Wiring

(1) Specifications of control wiring and maximum length of wiring

Transmission line is a type of control line. When the source of noise is located adjacent to the unit, the use of shield cable as well as moving the unit as far away from the noise source are recommended.

① Transmission line (M-NET transmission line)

System component		For multiple-refrigerant system
Wiring specifications	Length of transmission line	n/a
	Facility type (noise level measurement)	All types of facilities
	Cable type	Shield cable CVVS · CPEVS
	No. of cable	2-core cable
	Diameter	Over 1.25mm ²
Total length of indoor/outdoor transmission line		Maximum length: 200m Maximum length of centralized control transmission line and Indoor/Outdoor transmission line via indoor/outdoor units: 500m maximum

② Remote control wiring

		MA remote controller ※ 1
Wiring specifications	Cable type	VCTF · VCTFK · CVV · CVS · VVR · VVF · VCT
	No. of cable	2-core cable
	Diameter	0.3~1.25mm ² ※ 2 (0.75~1.25mm ²) ※ 3
Total Length		Maximum length: 200 m

※ 1: "MA remote controller" includes MA remote controller, Simple MA controller, and wireless remote controller.

※ 2: Cables with a diameter of 0.75mm² or smaller recommended for easier handling.

※ 3: When connecting to simple remote controller terminal, use a cable with a diameter within the range shown in the parenthesis.

8-3. Types of switch settings and setting methods

Whether a particular system requires switch settings depends on its components. Refer to the section "7-4 Wiring and Address Setting" before conducting electrical work.

Keep the power turned off while setting the switches. If settings are changed while being powered, the changed settings will not register, and the unit may malfunction.

Unit		Symbol	Turn off the power to
Outdoor unit		OC	Outdoor unit
Indoor unit	Main/sub controllers ※	IC	Indoor and outdoor units

※ 10HP has only the main controller

(1) Address setting

This system requires address setting. The range of address varies depending on the type of unit. Refer to “7-4 Wiring and Address Setting” for details.

Unit		Symbol	Address setting range	Setting method	Factory setting
Indoor unit	Main/sub controllers * 1	IC	01~50 * 2	Assign a number to all indoor units, starting with 1 and using sequential numbers. Use odd numbers for the top controller and even numbers for the bottom controller of the indoor units. Use odd numbers starting with 01 for 10HP system.	00
Outdoor Unit		OC	51~100 * 2 * 3	Add 50 to the address assigned to the indoor unit to which the outdoor or heat-source unit is connected.	00

* 1: 10HP only has the main controller.

* 2: Avoid using the same address as the ones used by the indoor/outdoor units in another refrigerant system; choose a different one in the range specified above.

* 3: When setting the address to 100, set the switch to 50.

(2) Setting the outdoor unit power-source switch connector (Factory setting: CN41 Connected)

System component	Power supply switch unit
Multiple-refrigerant system	<p><When power-supply unit is not connected to the centralized control transmission line> Replace the power source switch connector CN41 with CN40 on only one of the outdoor units</p> <p><When connecting the power-supply unit> Use CN41 as it is.</p>

(3) Choosing the temperature detection spot by indoor unit (Factory Setting: SWC “Standard”)

When using the suction temperature sensor, set SWC to “Option.”

(4) Setting the MA “Sub” controller

When using two remote controllers or running two indoor units as a group, one of the controllers must be set to “Sub” controller.

* No more than two remote controllers can be connected to a group.

(Factory setting: “Main”)

Set the controller according to the following procedure. Refer also to the instructions manual supplied with the MA remote controller.

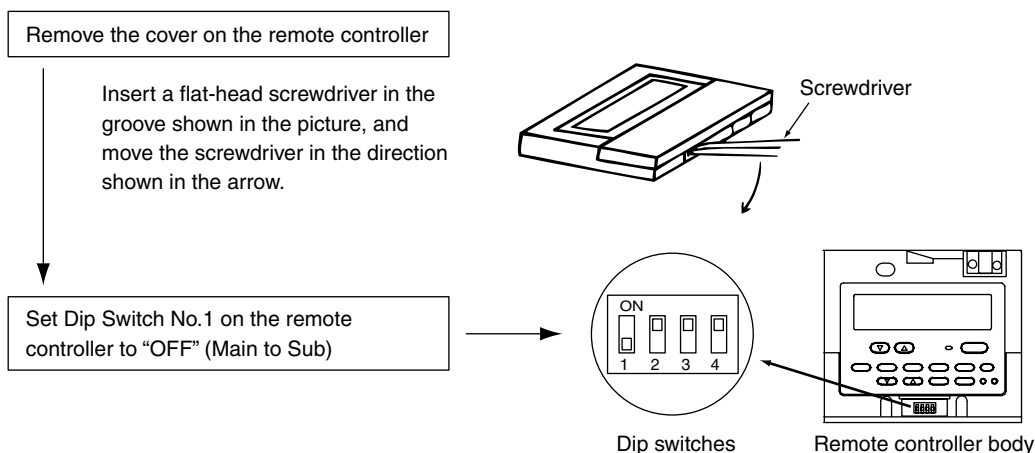

8-4.Wiring and Address Setting

(1) System Using MA Remote Controller

① System with one indoor unit (10HP system)

Control Wiring Diagram

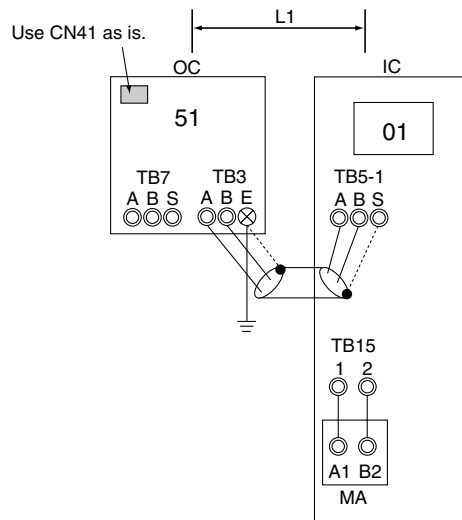

※There is one indoor controller board inside indoor unit.

Remarks

1. Use power supply connector (CN41) on the outdoor unit as is.
2. It is not necessary to ground the S terminal of centralized control transmission terminal board (TB7) on the outdoor unit.

Maximum Allowable Length

<a. Indoor/Outdoor transmission line>
 Maximum Length (above 1.25mm²)
 $L1 \leq 200\text{m}$

Wiring and Address Setting

<a. Indoor/Outdoor Transmission Lines >

Connect A, B terminals of indoor/outdoor transmission line terminal board (TB3) on the outdoor unit and A, B terminals of the Indoor/outdoor transmission terminal board (TB5). (Non-polar 2 wire)

* Only use shield line.

[Grounding the shield line]

Connect the earth terminal of the OC and S terminal of the IC terminal board (TB5).

<b. Switch Setting >

Set the address as follows.

Steps	Unit or Controller			Address Setting Range	Setting Procedures	Remarks	Factory Setting
1	Indoor Unit	Main Unit	IC	01 ~ 50	Set the address for the controller at the top of the indoor unit. Start with "01" then use sequential odd numbers (i.e.01, 03, 05).		00
2	Outdoor Unit		OC	51 ~ 100	Add 50 to the address assigned to the indoor unit within the same refrigerant system.		00
3	MA remote controller	Main Controller	MA	n/a	-		Main
		Sub Controller	MA	Sub controller	Use dipswitch to set the controller as sub controller.		

(1) System Using MA Remote Controller

② Unit with One Indoor Unit (20HP Systems)

Control Wiring Diagram

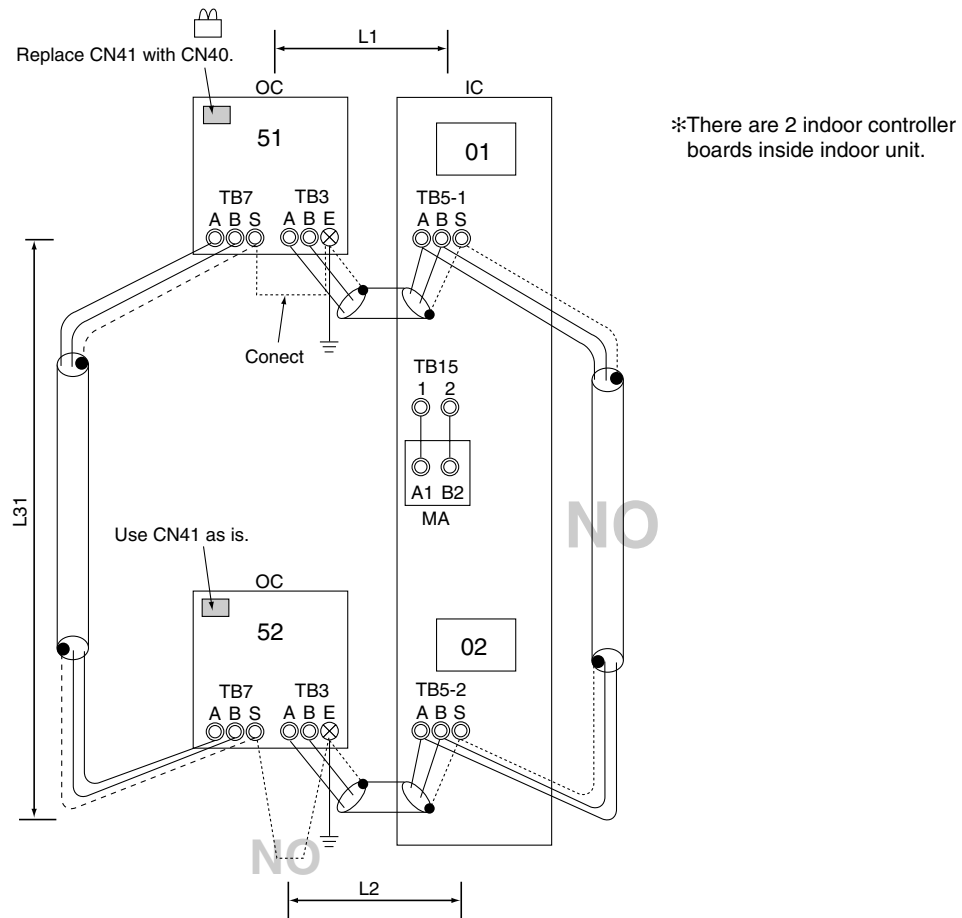

Remarks

1. Use sequential numbers to set indoor unit address.
2. Do not connect TB5s' of the indoor units that are connected to different outdoor units with each other.
3. Replace CN41 with CN40 on only one outdoor unit.
4. Ground only one of the outdoor units' S terminal of TB7 (centralized control transmission terminal).

Maximum Allowable Length

- <a. Indoor/Outdoor transmission line>**
 Maximum Length (above 1.25mm²)
 $L1, L2 \leq 200\text{m}$
- <b. Transmission line for centralized control>**
 Maximum length via outdoor unit (over 1.25mm²)
 $L1 + L3 + L2 \leq 500\text{m}$

Wiring and Address Setting

<a. Indoor/Outdoor Transmission Lines >

Connect A, B terminals of indoor/outdoor transmission line terminal board (TB3) on the outdoor unit and A, B terminals of the Indoor/outdoor transmission terminal board (TB5). (Non-polar 2 wire)

*Only use shield line.

[Grounding the shield line]

Connect the earth terminal of the OC and S terminal of the IC terminal board (TB5).

<b. Transmission Line for Centralized Control >

Connect A terminals of centralized control transmission line terminal board on each of the outdoor units with each other.

Do the same with B terminals. Replace CN41 (power supply switch connector) with CN40 on only one OC.

*Only use shield line.

[Grounding the shield line]

Connect S terminals of the TB7 of each of the outdoor units with each other.

Connect the S terminal of TB7 on the outdoor unit whose CN41 was replaced with CN40 to the earth terminal of the electric box.

<c. Switch Setting >

Set the address as follows.

Steps	Unit or Controller		Address Setting Range	Setting Procedures	Remarks	Factory Setting
1	Indoor Unit	Main Unit	IC	01 ~ 49	Set the address for the controller at the top of the indoor unit. Start with "01" then use sequential odd numbers (i.e.01, 03, 05).	00
		Sub Unit	IC	02 ~ 50		
2	Outdoor Unit		OC	51 ~ 100	Add 50 to the address assigned to the indoor unit within the same refrigerant system.	00
3	MA remote controller	Main Controller	MA	n/a	-	Main
		Sub Controller	MA	Sub controller	Use dipswitch to set the controller as sub controller.	

(1) System Using MA Remote Controller

③ When connecting 2 MA remote controller to one indoor unit (20HP Systems)

Control Wiring Diagram

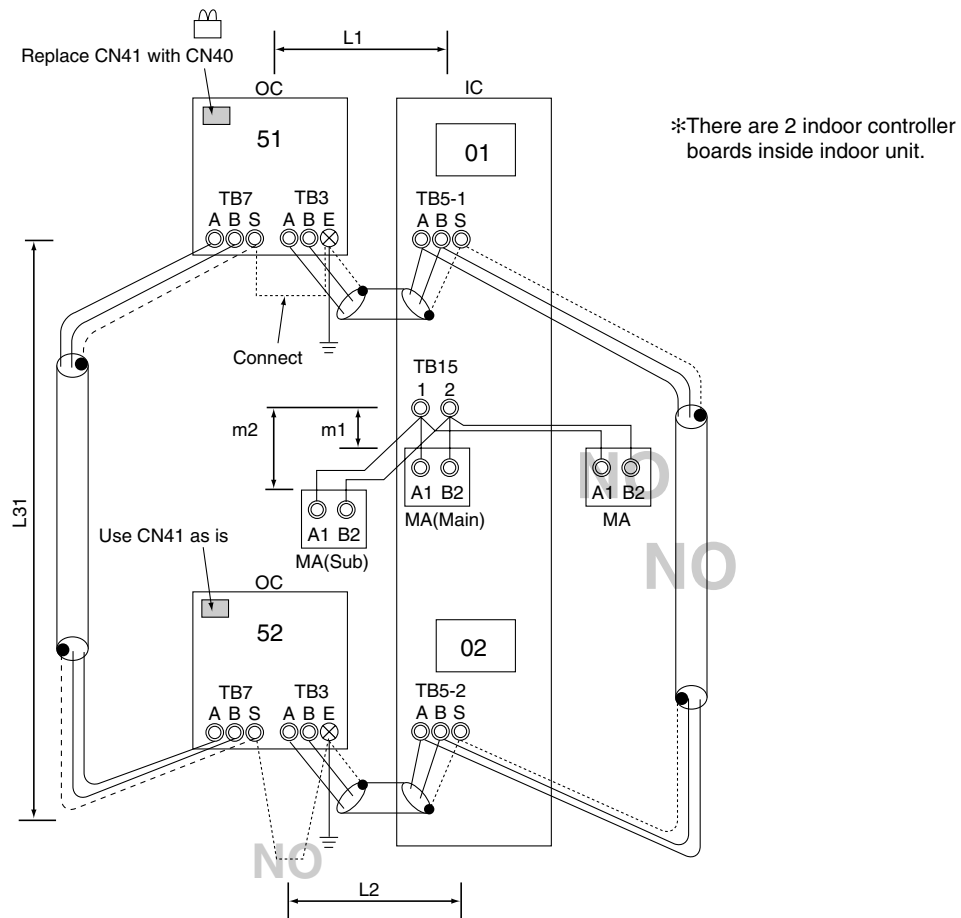

Remarks

1. Use sequential numbers to set indoor unit address.
2. Do not connect TB5s' of the indoor units that are connected to different outdoor units with each other.
3. Replace CN41 with CN40 on only one outdoor unit.
4. Ground only one of the outdoor units' S terminal of TB7 (centralized control transmission terminal).
5. No more than two main and sub controllers can be connected to the indoor unit in the same group. Disconnect the MA remote control wire from TB15 if using more than 2 remote controllers.

Maximum Allowable Length

- <a. Indoor/outdoor transmission line >
Same as (2).
- <b. Transmission line for centralized control >
Same as (2).
- <c. MA remote controller wiring >
Maximum allowable length (0.3 ~ 1.25mm²)
 $m1 + m2 \leq 200\text{m}$

Wiring and Address Setting

<a. Indoor/Outdoor Transmission Line >

Same as (2).

<b. Transmission Line for Centralized Control >

Same as (2).

<c. MA Remote Controller Wiring >

[When using 2 remote controllers]

When using two remote controllers, connect terminals 1 and 2 of TB15 on the indoor unit to terminal board of MA controller(option).

※ Set the connected MA remote controller (option) as sub controller (Refer to manual that came with MA remote controller.)

<d. Switch Setting >

Set the address as follows.

Steps	Unit or Controller			Address Setting Range	Setting Procedures	Remarks	Factory Setting
1	Indoor Unit	Main Unit	IC	01 ~ 49	Set the address for the controller at the top of the indoor unit. Start with "01" then use sequential odd numbers (i.e.01, 03, 05). Add 1 to the address assigned to the main unit in the same room.		00
		Sub Unit	IC	02 ~ 50			
2	Outdoor Unit		OC	51 ~ 100	Add 50 to the address assigned to the indoor unit within the same refrigerant system.		00
3	MA remote controller	Main Controller	MA	n/a	-		Main
		Sub Controller	MA	Sub controller	Use dipswitch to set the controller as sub controller.		

(1) System Using MA Remote Controller

④ When grouping 2 indoor units (20HP systems) with MA remote controller

Control Wiring Diagram

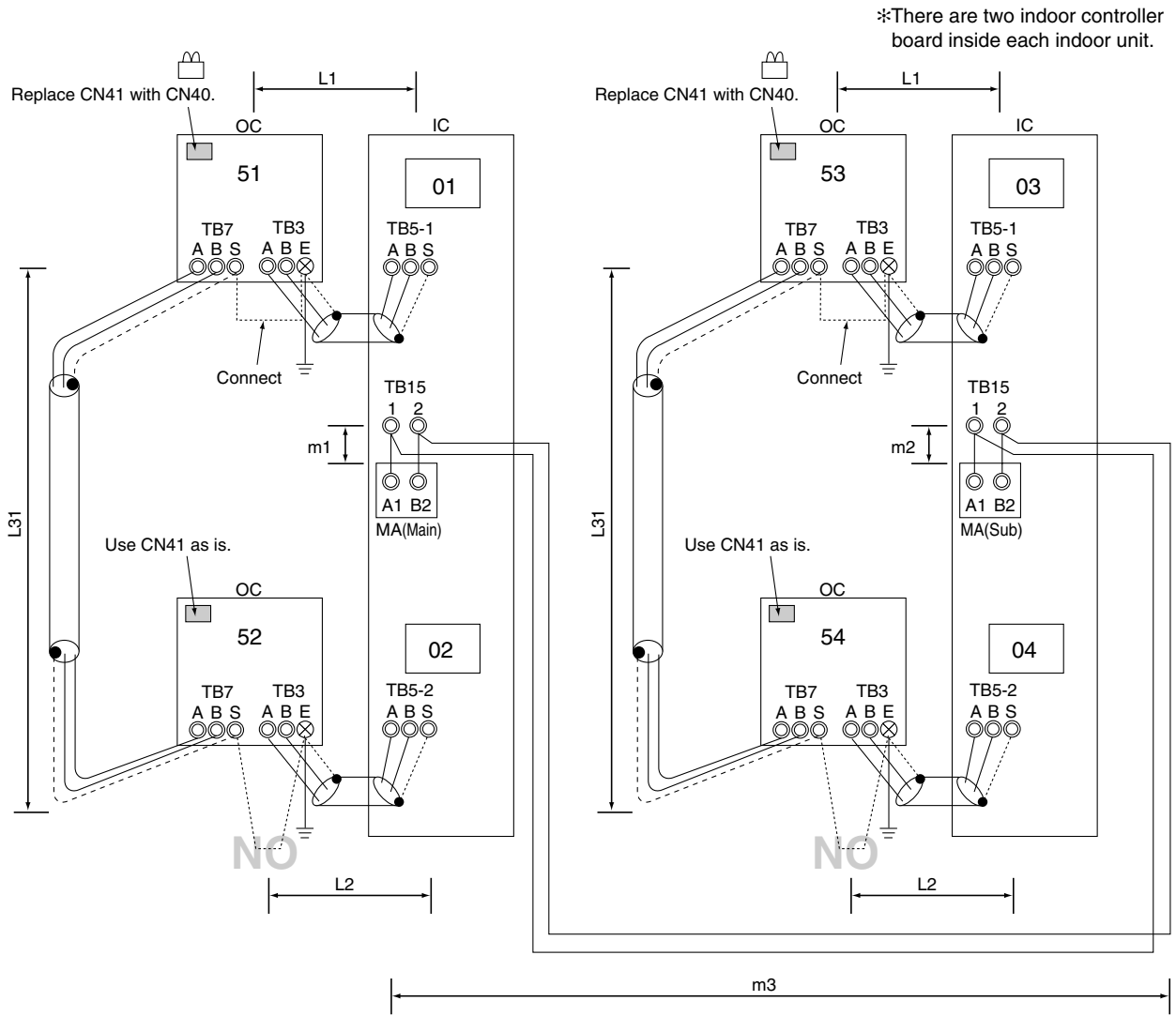

Remarks

1. Use sequential numbers to set indoor unit address.
2. Do not connect TB5s' of the indoor units that are connected to different outdoor units with each other.
3. Replace CN41 with CN40 on only one outdoor unit.
4. Ground only one of the outdoor units' S terminal of TB7 (centralized control transmission terminal).
5. No more than two main and sub controllers can be connected to the indoor unit in the same group. Disconnect the MA remote control wire from TB15 if using more than 2 remote controllers.

Maximum Allowable Length

- <a. Indoor/outdoor transmission line >
Same as (2).
- <b. Transmission line for centralized control >
Same as (2).
- <c. MA remote controller wiring >
Maximum allowable length (0.3 ~ 1.25mm²)
 $m1 + m2 + m3 \leq 200m$

Wiring and Address Setting

<a. Indoor/Outdoor transmission line >

Same as (2).

<b. Transmission Line for Centralized Control >

Same as (2).

<c. MA remote controller line >

* When grouping units that use different refrigerants, set MA remote controller of one of the indoor units as sub controller.

[When grouping indoor units]

When grouping indoor units, connect 1 and 2 terminals of both IC terminal boards (TB15) with each other (non-polar 2 line).

* Set MA remote controller of one of the indoor units as sub controller.

<d. Switch Setting >

Set the address as follows.

Steps	Unit or Controller			Address Setting Range	Setting Procedures	Remarks	Factory Setting
1	Indoor Unit	Main Unit	IC	01 ~ 49	Set the address for the controller at the top of the indoor unit. Start with "01" then use sequential odd numbers (i.e.01, 03, 05). Add 1 to the address assigned to the main unit in the same room.		00
		Sub Unit	IC	02 ~ 50			
2	Outdoor Unit		OC	51 ~ 100	Add 50 to the address assigned to the indoor unit within the same refrigerant system.		00
3	MA remote controller	Main Controller	MA	n/a	-		Main
		Sub Controller	MA	Sub controller	Use dipswitch to set the controller as sub controller.		

(1) System Using MA Remote Controller

⑤ When grouping multiple indoor units (combination of 10HP, 20HP systems)

Control Wiring Diagram

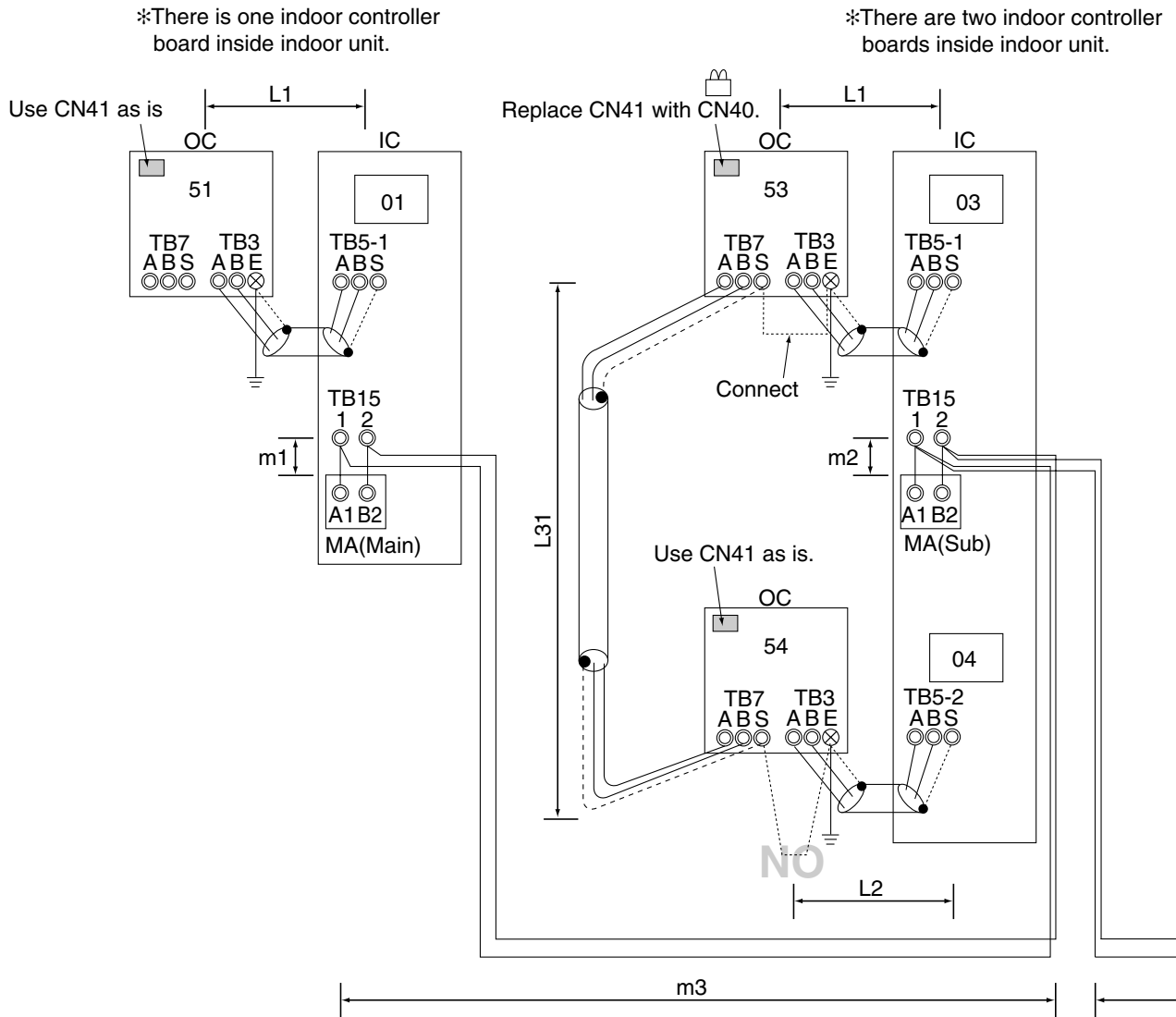

Remarks	Maximum Allowable Length
<ol style="list-style-type: none"> 1. Use odd numbers to set 10HP indoor unit address. 2. When setting unit address for 20HP indoor unit, use odd numbers for the top controllers and even numbers for the bottom controllers (main controller+1). 3. Replace CN41 (power supply switch connector) with CN40 on only one 20HP outdoor unit. 4. Ground the S terminal of TB7 (centralized control transmission terminal board) of only one of the 20HP outdoor units. 5. No more than two main and sub controllers can be connected to the indoor unit in the same group. Disconnect the MA remote control wire from TB15 if using more than 2 remote controllers 	<p><a. Indoor/Outdoor Transmission Line > Same as (2).</p> <p><b. Transmission Line for Centralized Control > Same as (2).</p> <p><c. MA Remote Controller Line > Total Length (0.3 ~ 1.25mm²) $m1 + m2 + m3 + m4 + m5 \leq 200m$</p>

Control Wiring Diagram

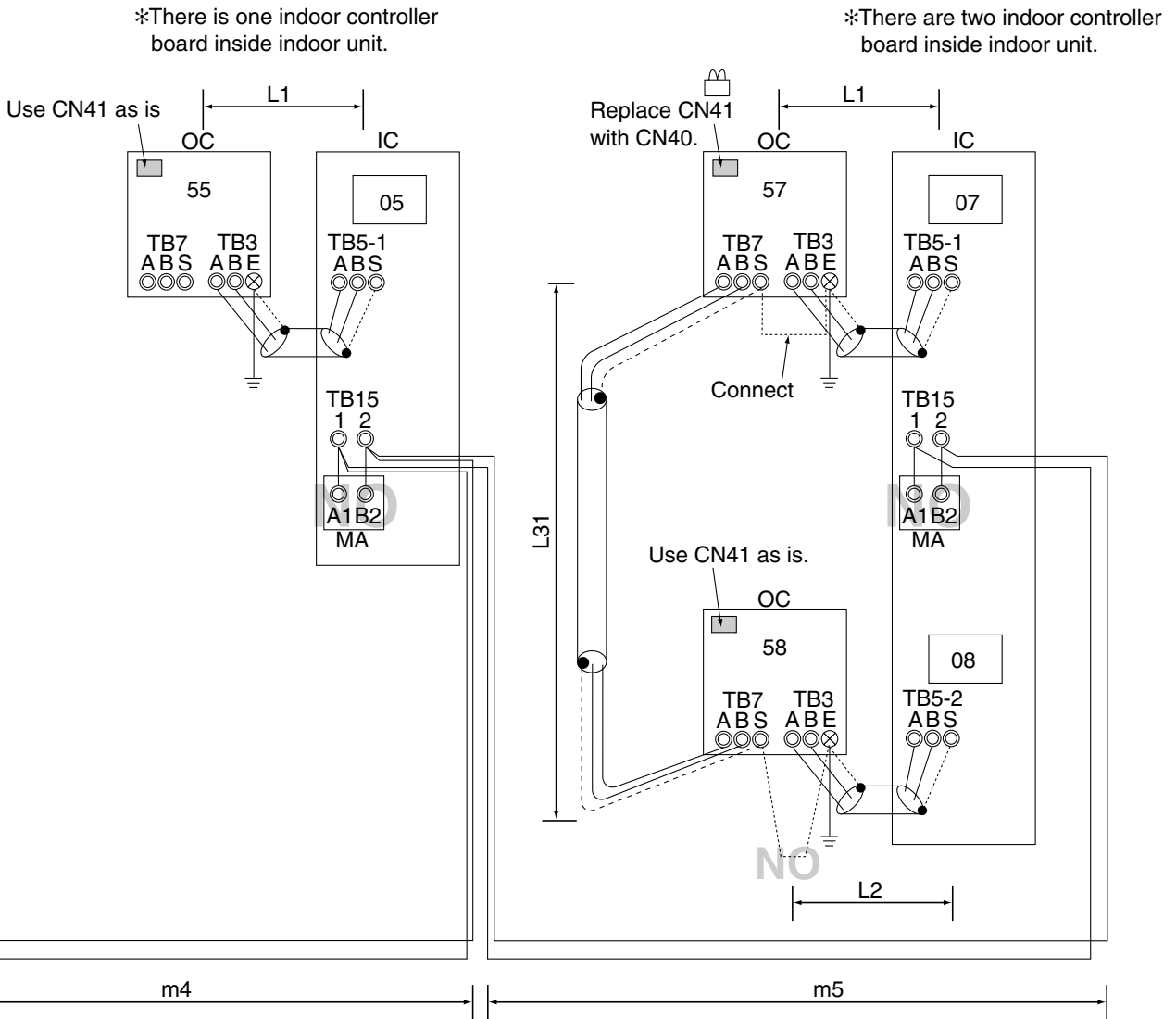

Steps	Unit or Controller		Address Setting Range	Setting Procedures	Remarks	Factory Setting
1	Indoor Unit	Main Unit (10HP, 20HP)	IC 01 ~ 49	Set the address for the controller at the top of the indoor unit. Start with "01" then use sequential odd numbers (i.e.01, 03, 05).		00
		Sub Unit (20HP)	IC 02 ~ 50	Add 1 to the address assigned to the main unit in the same room.		
2	Outdoor Unit		OC 51 ~ 100	Add 50 to the address assigned to the indoor unit within the same refrigerant system.		00
3	MA remote controller	Main Controller	MA n/a	-		Main
		Sub Controller	MA Sub controller	Use dipswitch to set the controller as sub controller.		

(2) System with MA remote controller and G-50A

① System with multiple indoor units (10HP, 20HP)

Control Wiring Diagram

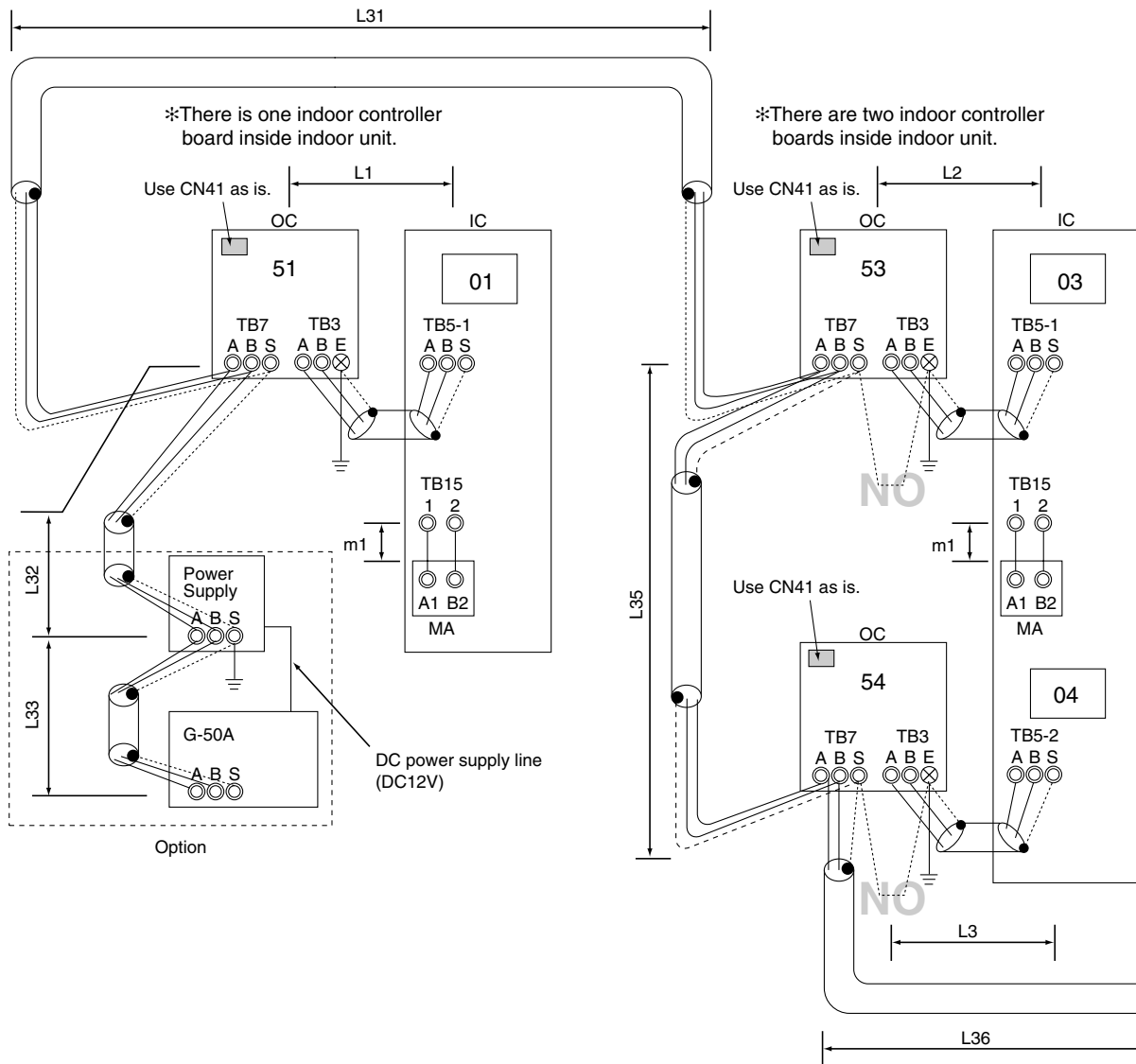

Remarks

1. Be sure to use odd numbers to set the address for indoor units (10HP).
2. To set the indoor unit address for 20HP, use odd numbers for the top controllers and use even numbers for the bottom controllers (Main controller plus 1).
3. Use the power supply switch connector (CN41) on the outdoor unit as is.
4. It is not necessary to ground the S terminal of transmission line terminal board for centralized controller on the outdoor unit.
5. No more than two main/sub remote controllers can be connected to the indoor unit in the same group. When more than two remote controllers are present in the system, disconnect MA remote controller from TB15 in the indoor unit.
6. Put both types of the addresses for P500-type indoor units in the same group when setting groups for indoor units with a remote controller.

Maximum Allowable Length

- <a. Indoor/Outdoor transmission line>**
 $L1, L2, L3, L4, L5, L6 \leq 200\text{m}$
- <b. Transmission Line for Centralized Control >**
 $L31 + L32 + L33 + L35 + L36 + L37 + L38 + L6 \leq 500\text{m}$
 $L1 + L31 + L35 + L36 + L37 + L38 + L6 \leq 500\text{m}$
- <c. MA Remote Controller Line >**
 Total Length (0.3 ~ 1.25mm²)
 $m1 \leq 200\text{m}$

Control Wiring Diagram

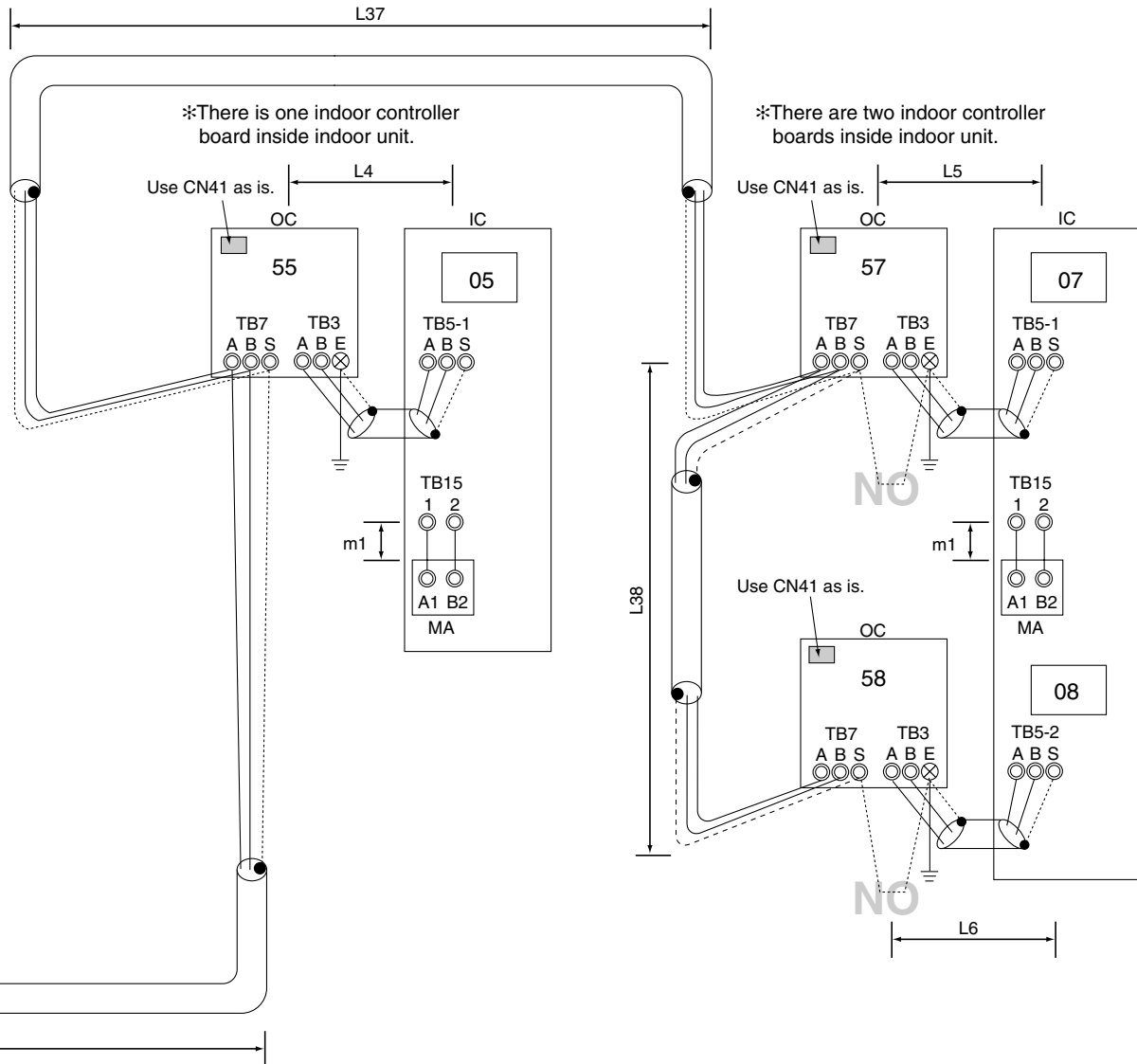

Steps	Unit or Controller		Address Setting Range	Setting Procedures	Remarks	Factory Setting
1	Indoor Unit	Main Unit (10HP, 20HP)	IC 01 ~ 49	Set the address for the controller at the top of the indoor unit. Start with "01" then use sequential odd numbers (i.e.01, 03, 05).		00
		Sub Unit (20HP)	IC 02 ~ 50	Add 1 to the address assigned to the main unit in the same room.		
2	Outdoor Unit		OC 51 ~ 100	Add 50 to the address assigned to the indoor unit within the same refrigerant system.		00
3	MA remote controller	Main Controller	MA n/a	-		Main
		Sub Controller	MA Sub controller	Use dipswitch to set the controller as sub controller.		

8-5.External input/output specifications

(1) Input/output specifications

Input

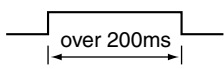
Function	Usage	Signals
Start/stop	Turning ON/OFF the indoor unit	Pulse (a-contact with voltage/without voltage) ※1 <With voltage> Power Source: DC12~24V Electrical Current: Approximately 10mA (DC12V) <Standard Pulse> 

※1 Use minute-current contact (DC12V 1mA)

Output

Function	Usage	Signal
No.1 Operation Status	Obtaining signals indicating operation status of indoor units in each refrigerant circuit.	Relay a-contact output DC 30V or AC 100V/200V
No. 1 Error Status	Obtaining signals indicating error status of indoor units in each refrigerant circuit.	Standard Current : 1A Minimum Current : 1mA
No. 2 Operation Status ※	Obtaining signals indicating operation status of indoor units in each refrigerant circuit.	
No. 2 Error Status ※	Obtaining signals indicating error status of indoor units in each refrigerant circuit.	

※ 20HP only

(2) Wiring

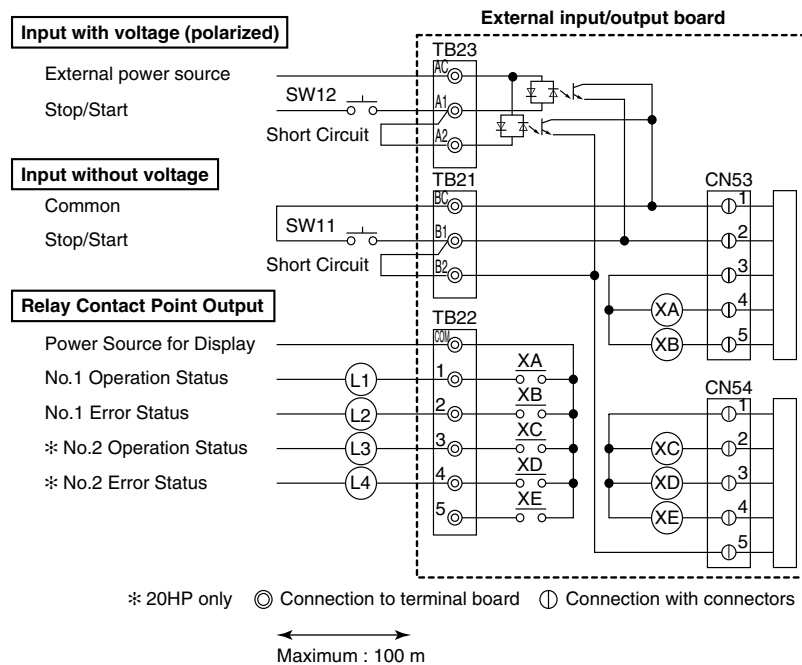

<Input with Applied Voltage (polarized)>

External power source	DC12~24V Electrical current input (per contact) Approximately 10mA (DC12V)
SW12	Remote start/stop switch Each pressing of the SW (Pulse input) switches between ON and OFF.

<Input without voltage applied>

SW11	Remote start/stop ※ Each pressing of the SW (Pulse input) switches between ON and OFF.
Minute-current contact: DC12V 1mA	

<Relay contact output>

Power supply for displays	DC30V 1A AC220-240V 1A	L3	No.2 Operation Status Indicator Lamp
L1	No.1 Operation Status Indicator Lamp	L4	No.2 Error Status Indicator Lamp
L2	No.1 Error Status Indicator Lamp	XA~XE	Relay (Permissible Electrical Current: 10mA~1A)

● Setting on the Indoor Unit

Confirm the following setting when using external input.

- ① No.1, No.2 Controller board Dip SW 3-8: ON (Factory Setting: ON; External input will not be available when OFF.)
- ② No.1, No.2 address board Dip SW 1-10: OFF (Factory Setting: OFF; External input will not be available when ON.)
- ③ Normal/Local switch inside the unit controller box is set to "Normal." (Factory Setting: Normal; External input will not be available when it is set to "Local.")

(3) Wiring Method

- ① Check the indoor unit setting (Refer to 7-5.(2) Wiring)
- ② When using the external output function, connect each signal line to External output Terminal (TB22) on the unit, depending on the usage.
- ③ When using external input function, peel the outer layer of the signal line off, and connect it to external input terminal (TB21 or TB23) on the unit, depending on the usage.

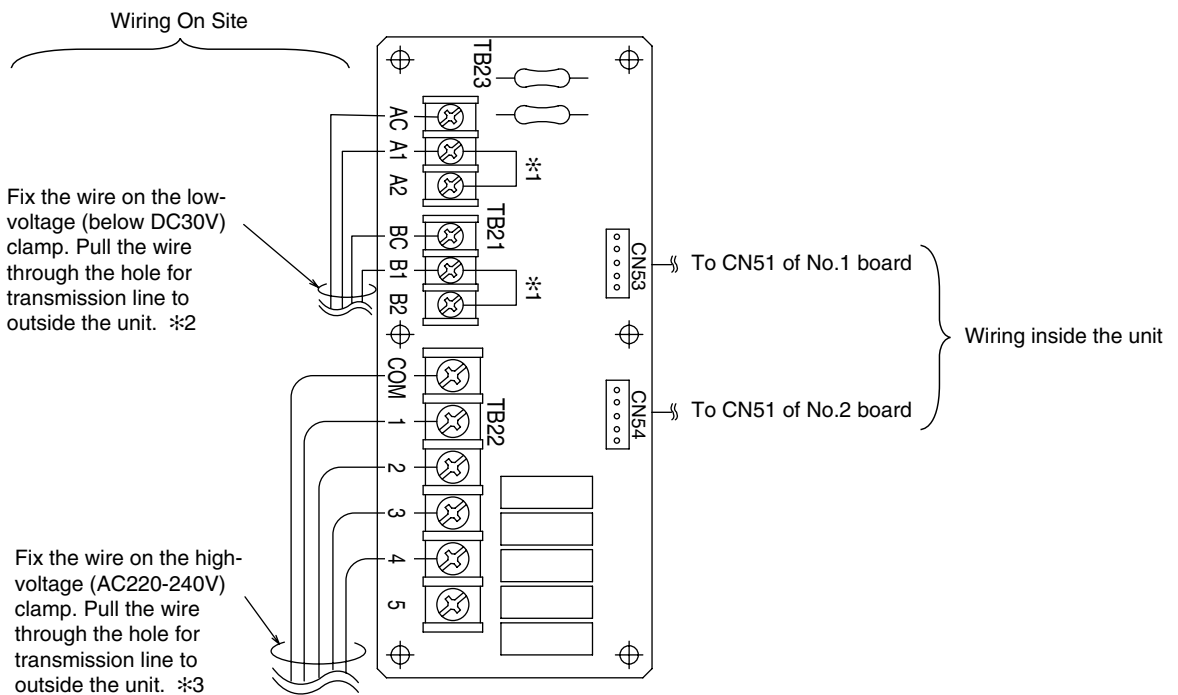

- *1 20HP indoor unit is shipped with B1 and B2 terminals of TB21 and A1 and A2 terminals of TB23 short-circuited respectively. When connecting wire to those terminals, do not eliminate this feature. If it is eliminated, the units in one of the 2 refrigerant circuits may not operate.
- *2 Do not bundle with high-voltage (AC220-240V) wire, since noise interference from such wire may cause the unit to malfunction.
- *3 Do not bundle with minute-voltage (DC30V or below) wire, since noise interference from such wire may cause the unit to malfunction.

⚠ Caution

- 1) Wiring should be covered by insulation tube with supplementary insulation.
- 2) Use relays or switches with IEC or equivalent standard.
- 3) The electric strength between accessible parts and control circuit should have 2750V or more.
- 4) TB21 is a terminal specifically for No-voltage contact point input. Do not apply voltage to TB21, since it must result in malfunction of indoor unit controller board.
- 5) TB23 is specifically for contact point input with voltage. Check the polarity before connecting to avoid damage to the unit.
- 6) **Keep the wires on the input side and on the output side away from each other when using AC220-240V as a power source for displays.**
- 7) Keep the length of the extension part of external signal line under 100m.
- 8) 20HP is shipped with B1 and B2 terminals of TB21 and A1 and A2 terminals of TB23 short-circuited respectively. Do not eliminate this feature. If it is eliminated, the units in one of the two refrigerant circuits may not operate.

9. Air Conditioning the Computer Room

9-1 Main Features of the Floor-Duct Air Conditioners

This system is installed by building a floor over an existing floor and using the space between these two floors as an air-conditioning duct.

This system has the following characteristics:

- ① The temperature and humidity can efficiently and reliably be controlled, since the air-conditioned air is sent directly to the machine.
- ② It provides a comfortable environment for the operator, since the air can be conditioned to best suit the needs of the operator and machines.
- ③ It is favorable in terms of appearance because the air-conditioning duct is out of sight.
- ④ The location of the duct is irrelevant when considering adding new machines or rearranging the existing machines, since the entire floor serves as the air duct.

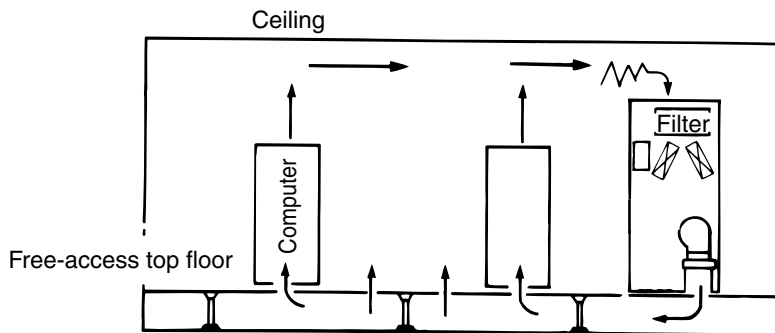

Caution

- (1) Unlike plenum ventilation and overhead-duct type conditioners, since the conditioned air is not mixed with the air in the room, the air that comes out of the unit has to meet the predetermined conditions (constant temperature/constant humidity) at the time the air exits the unit. Close attention must be paid to the auto-controlling system.
- (2) Dust in the duct space (between the free-access top floor and the existing floor) must be thoroughly removed before installing the unit.
- (3) Since the existing floor is cooled by the unit, it may produce dews on the ceiling of the room down below.

9-2 Major Characteristics of Computer Room Air Conditioners (Constant Temperature · Constant Humidity)

A computer-room air conditioner is a device that is used to maintain certain temperature and humidity in the room. Especially, floor-duct conditioners must be able to provide air that meets predetermined requirements. In this unit, the compressor works year around. To respond to the change in temperature, the capacity control compressor regulates the temperature. Since this unit does not ship with a humidifier, humidity is controlled with the use of a humidifier installed in the room.

9-3 Step-by-Step Plan for the Implementation of the Air-Conditioning

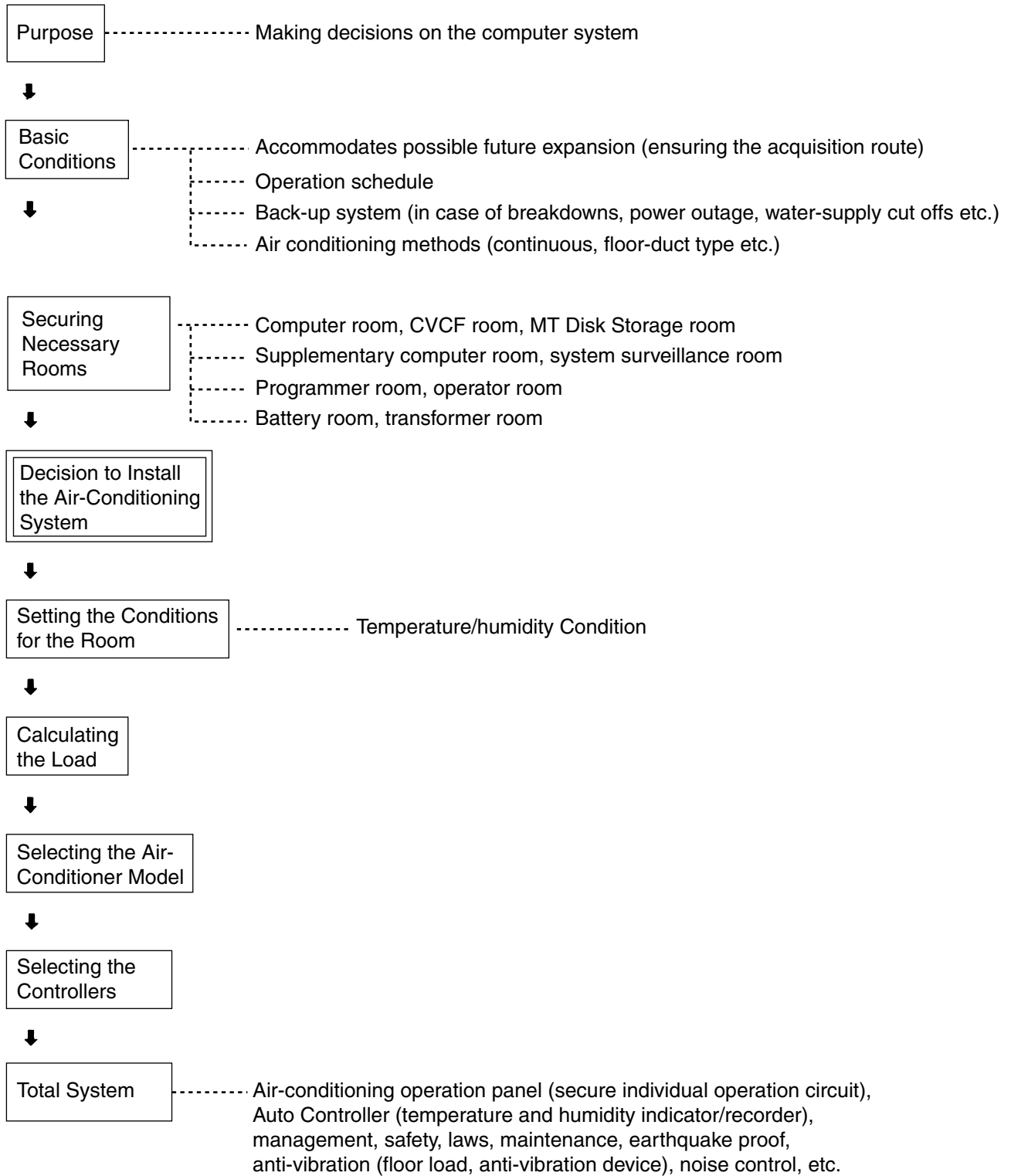

9-4 Conditions for the Installation of Computer-Room Air Conditioners

(1) Outdoor Temperature and Humidity

Generally the values set for general air conditioners are used, although the value higher than the maximum outdoor temperature and humidity may be set for devices like computer-room air conditioners that must keep the air temperature and humidity under predetermined levels.

(2) Indoor Temperature and Humidity

There is a wide range of conditions set by different computer manufacturers, and the conditions need to be set in consultation with the manufacturers. The most basic conditions include keeping dew condensation and static electricity from forming. It is also necessary to keep the room free of dust to ensure a smooth operation of the computer.

(3) Matching the Volume of Air Flow

It is possible to use the fan on the computer to cool the room. This controlling method requires a certain volume of cold air in proportion to the amount of heat produced by the device. The inlet panel is located at the bottom of the unit, and the exhaust pipe is located either on the ceiling, front and back, or on the side.

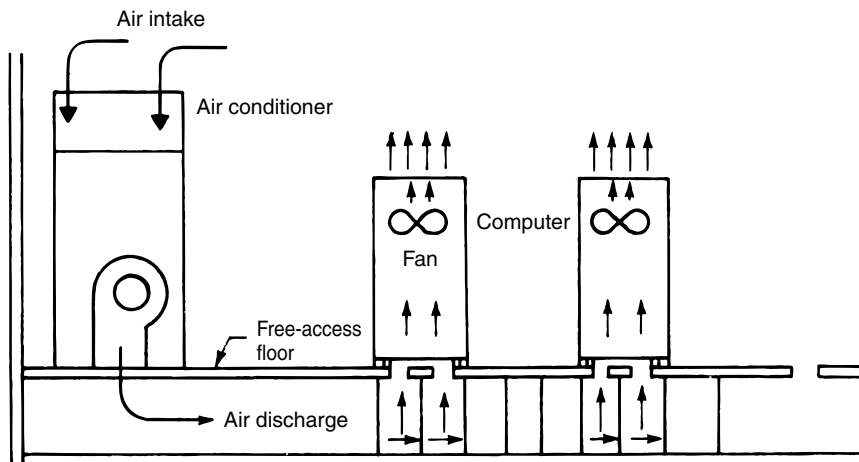

(4) Considering a Back-up Air Conditioning System

When the system is not allowed to stop at all, a back-up system is necessary. There are several different options for a back-up as the following:

- ① Installing two sets of air conditioning systems necessary for the computer.
- ② Utilizing regular office air conditioners (for people)
- ③ Using one of the units as a back-up

① is used infrequently due to high costs involved. ② involves many technical problems such as the difference between preset conditions for computer rooms and office rooms. In general, ③ is a preferred method. If ③ is chosen, the unit method (package method) is more economical than the central method.

9-5 Setting the Air conditioners

(1) Air-Conditioning Load

- ① Once the floor plan is made and the conditions for the air-conditioning system are set, air conditioning capacity has to be determined by calculating the load.
- ② Unlike the outdoor air, computer load remains constant throughout the year. However, it is possible that there are considerable fluctuations within a day. This is due to the fact that, depending on the time of the day, there are changes in the number of computers that are turned on and that the different computer systems are in operation.
- ③ If there is a plan to expand the current computer system in the future, it is important to include the load for the units to be added in the future when calculating the thermal load because it is practically impossible to keep the computers off for days on end during the installation of the new units.
- ④ The following items need to be checked before calculating the unit capacity:
 - Floor area of the computer room (m²)
 - Total quantity of heat generated by computers

(2) Sample Selection of Air Conditioners

(2-1) Conditions

Computer-generated heat	20.9kW
Number of workers	5
Lighting	20W/m ²
Temperature and humidity	Indoor °CDB/Indoor WBT : 24°C/17°C °CDB of the air going into the computer : 18°C
Frequency	60Hz

(2-2) Building Conditions

Windows	(W: 4.5m, H: 1.5m) × 2
Inside Measurement	Ceiling height 2.2m
Surroundings	Upstairs room, downstairs room, heat and air conditioning

① Coefficient of Overall Heat Transmission U (W/m² ·K)

Outer Walls	Summer 3.6, Winter 3.8
Inner Walls	2.05
Ceiling	Downward convection 3.36, upward convection 3.3
Floor (free access)	Downward convection 3.05, upward convection 4.56
Floor	Downward convection 2.42, upward convection 3.3
Windows	Summer 5.93, Winter 6.5

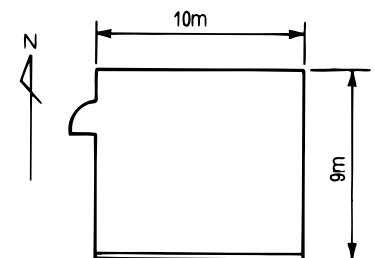

Window

② Internal Load

Number of People in the Room	5
Lighting	20W/m ²
Calculator	20.9kW
Draft	0.2 times/h

③ Volume of Outdoor Air Intake

25m³/h·person

(2-3) Calculating the Load and Selecting a Model

Calculate the temperature difference by setting the outdoor temperature; then, calculate hourly loads.

The chart shows the result of a calculation, supposing that the system reaches its highest load at 12 o'clock.

Outdoor temperatures in this example Summer : 32°CDB relative humidity 60%

Winter : -2°CDB relative humidity 42%

① Load (in the summer with air-conditioning)

< Sensible Heat > SH

Computer		20.9 kW
Lighting	1,800W	1.8 kW
Number of people in the room	5 persons × 64 (U)	0.32 kW
Infiltration draft	(0.2 times/h) 39.6m ³ × 0.336 × 8	0.11 kW
Outer wall (heat transmission)	8.5m ² × 3.6 × 8	0.25 kW
Windows (radiation)	13.5m ² × 0.65 × 188	1.91 kW
Windows (heat transmission)	13.5 × 5.93 × 8	0.64 kW
Inner wall(heat transmission)	61.6 × 2.05 × 4	0.5 kW
Outside air	125m ³ × 0.336 × 8	0.34 kW
Total		26.8 kW

< Latent Heat > LH

Infiltration draft	39.6 × 834 × 0.0117	0.39 kW
Number of people in the room	5 persons × 82	0.41 kW
Outside air	125m ³ × 834 × 0.0117	1.22 kW
Total		2.0 kW

Total load is 28.8kW

② Necessary Air Circulation

$$V = \frac{26800}{0.336 \times (24 - 18)} \div 60 = 221\text{m}^3/\text{min}$$

③ Model Selection

PUY-P250YMF-C × 2, PFD-P500VM-A type

Indoor °CDB 24°C / Indoor °CWB 17°C outdoor °CDB 32°C

Capacity of the Moment 51.5kW SHF = 0.92

Capacity of Sensible Heat 51.5 × 0.92 = 47.4/kW

Standard Air-Flow Volume: 320m³/min can be accommodated with PUY-P250YMF-C × 2 and PFD-P500VM-A.

9-6 Automatic Control of the Computer Room

Example

PFD-P560VM-A automatically controls the cooling temperature with a built-in controller.

(suction temperature or discharge temperature control)

This unit is designed for high sensible-heat specifications, and it does not include a humidifier or a dehumidifier. Install such components as necessary.

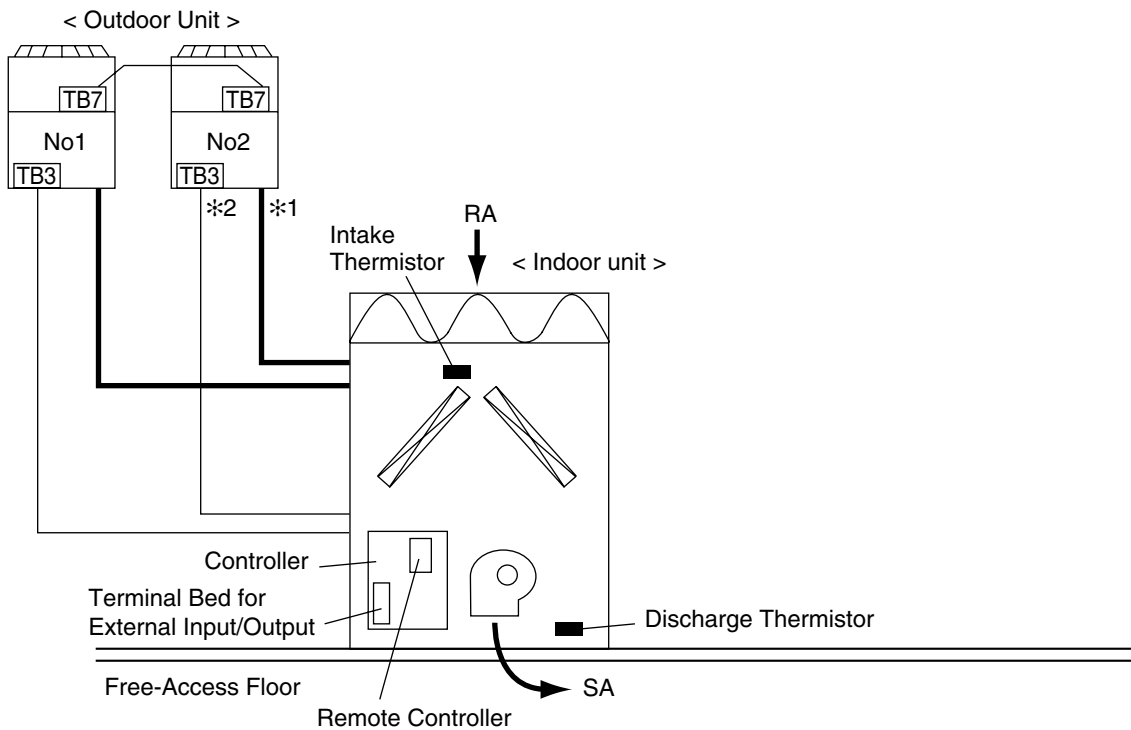

*1 Bold lines in the diagram indicate refrigerant piping (gas/liquid).

This system consists of 2 refrigerant circuits.

*2 Indicates TB3-type transmission line used to communicate with the indoor unit.

This system is made up of 2 circuits.

10. Maintenance/Inspection

10-1. Maintenance/Inspection Schedule

Having the units inspected by a specialist on a regular basis, in addition to regular maintenance such as changing the filters, will allow the users to use them safely and in good condition for an extended period of time.

The chart below indicates standard maintenance schedule.

(1) Approximate Longevity of Various Parts

The chart shows an approximate longevity of parts. It is an estimation of the time when old parts may need to be replaced or repairs need to be made.

It does not mean that the parts must absolutely be replaced (except for the fan belt).

Please note that the figures in the chart do not mean warranty periods.

Unit	Parts	Check every	Replace after	Daily check	Periodically check	Remarks
Indoor	Fan Motor	6 months	40000 hours		Yes	
	Bearing	6 months	40000 hours		Yes	Add lubricant once a year
	Fan Belt	6 months	8000 hours		Yes	Disposable parts
	Air Filter	3 months	5 years	Yes		
	Drain Pan	6 months	8 years		Yes	Maintenance schedule changes depending on the local conditions
	Drain Hose	6 months	8 years		Yes	
	Linear Expansion Valve	1 year	25000 hours		Yes	
	Heat Exchanger	1 year	5 years		Yes	
	Float Switch	6 months	25000 hours		Yes	
	Indicator Lamp	1year	8000 hours		Yes	
Outdoor	Compressor	6 months	40000 hours		Yes	
	Fan motor	6 months	40000 hours		Yes	
	Linear Expansion Valve	1 year	25000 hours		Yes	
	Heat Exchanger	1 year	5 years		Yes	
	Pressure Switch	1 year	25000 hours		Yes	
	Inverter Cooling Fan	1 year	40000 hours		Yes	

(2) Notes

- The above chart shows a maintenance schedule for a unit that is used under the following conditions:
 - A. Less than 6 times per hour of compressor stoppage
 - B. The unit stays on 24 hours a day.
- Shortening the inspection cycle may need to be considered when the following conditions apply:
 - ① When used in high temperature/high humidity area or when used in a place where the temperature and/or humidity fluctuate greatly
 - ② When plugged into an unstable power source (sudden change in voltage, frequency, wave distortions) (Do not exceed the maximum capacity.)
 - ③ When the unit is installed in a place where it receives vibrations or major impacts.
 - ④ When used in a place with poor air quality (containing dust particles, salt, poisonous gas such as sulfuric acid gas and sulfuric hydrogen gas, oil mist).
- Even when the above maintenance schedule is followed, there could be unexpected problems that cannot be predicted.
- Holding of Parts

We will hold parts for the units for at least 9 years after the termination of the production of the unit, following the standards set by the ministry of economics and industries.

Details of Maintenance/Inspection

Unit	Parts	Inspection Cycle	Check points	Assessment	What to do
Indoor	Fan motor	6 months	<ul style="list-style-type: none"> · Check for unusual noise · Measure the insulation resistance 	<ul style="list-style-type: none"> · Free of unusual noise · Insulation resistance over 1MΩ 	Replace when insulation resistance is under 1MΩ
	Bearing		<ul style="list-style-type: none"> · Check for unusual noise 	<ul style="list-style-type: none"> · Free of unusual noise 	If the noise doesn't stop after lubrication, change the oil. Add lubricant once a year.
	Fan belt		<ul style="list-style-type: none"> · Check for excessive slack · Check for wear and tear · Check for unusual noise 	<ul style="list-style-type: none"> · Resistance (3-4kg/belt) · Adequate amount of slack=5mm · Belt length=no longer than 102% of the original length · Free of wear and tear · Free of unusual noise 	Adjust the belt Replace if the belt length exceeds 2% of the original length, worn, or used over 8000 hours
	Air filter	3 months	<ul style="list-style-type: none"> · Check for clogging and tear · Clean the filter 	<ul style="list-style-type: none"> · Clean, free of damage 	Clean the filter Replace if extremely dirty or damaged
	Drain pan	6 months	<ul style="list-style-type: none"> · Check for clogging of the drainage system · Check for loosened bolts · Check for corrosion 	<ul style="list-style-type: none"> · Clean, free of clogging · Free of loose screws · No major disintegration 	Clean if dirty or clogged Tighten bolts Replace if extremely worn
	Drain hose		<ul style="list-style-type: none"> · Make sure the loop of the hose has water to prevent air from traveling through the hose (Fill the hose with water) · Check for clogging of the drainage system 	<ul style="list-style-type: none"> · Clean, free of clogging · Free of wear and tear 	Clean if dirty or clogged Replace if extremely worn
	Linear expansion valve	1 year	<ul style="list-style-type: none"> · Perform an operation check using the operation data 	<ul style="list-style-type: none"> · Adequately controls the air temperature (Check temperature change on the centralized controller) 	Replace if malfunctioning
	Heat exchanger		<ul style="list-style-type: none"> · Check for clogging, dirt, and damage 	<ul style="list-style-type: none"> · Clean, free of clogging or damage 	Clean
	Float switch	6 months	<ul style="list-style-type: none"> · Check the outer appearance · Make sure its free of foreign objects 	<ul style="list-style-type: none"> · Free of frayed or cut wires · Free of foreign objects 	Replace if damaged or extremely worn Remove foreign objects
	Indicator lamp	1 year	<ul style="list-style-type: none"> · Make sure the lamp comes on 	<ul style="list-style-type: none"> · Comes on when the output is on 	Replace if the light does not come on when the power is on
Outdoor	Compressor	6 months	<ul style="list-style-type: none"> · Check for unusual noise · Check insulation resistance · Check for loosened terminals 	<ul style="list-style-type: none"> · Free of unusual sound · Insulation resistance over 1MΩ · Free of loosened terminals 	Replace if insulation resistance goes below 1MΩ (under the condition that the refrigerant is not liquefied) Tighten loosened bolts
	Fan motor		<ul style="list-style-type: none"> · Check for unusual noise · Measure insulation resistance 	<ul style="list-style-type: none"> · Free of unusual sound · Insulation resistance over 1MΩ 	Replace if insulation resistance goes below 1MΩ
	Linear expansion valve	1 year	<ul style="list-style-type: none"> · Perform an operation check using the operation data 	<ul style="list-style-type: none"> · Adequately controls the air temperature (Check temperature change on the centralized controller) 	Replace if malfunctioning
	Heat exchanger		<ul style="list-style-type: none"> · Check for clogging, dirt, and damage 	<ul style="list-style-type: none"> · Clean, free of clogging or damage 	Clean
	Pressure switch		<ul style="list-style-type: none"> · Check for torn wire, fraying, and unplugged connectors · Check insulation resistance 	<ul style="list-style-type: none"> · No frayed or cut wires or unplugged connectors · Insulation resistance over 1MΩ 	Replace when cut or shorted, when the insulation resistance goes below 1MΩ, or if there is a history of abnormal operation
	Inverter cooling fan		<ul style="list-style-type: none"> · Check for unusual sound · Measure insulation resistance · Look for abnormal history 	<ul style="list-style-type: none"> · Free of unusual sound · Insulation resistance over 1MΩ · No heatsink overheat protection (4230,4330) on the report 	Replace when producing unusual sounds, when insulation resistance goes under 1MΩ, or if there is a history of abnormal operation.



HEAD OFFICE: MITSUBISHI DENKI BLDG., 2-2-3, MARUNOUCHI, CHIYODA-KU, TOKYO 100-8310, JAPAN
