

Air-Conditioners For Building Application HEAT SOURCE UNIT

CE

PQRY-P400·500YSGM-A

For use with R410A

GB

D

F

E

I

NL

P

GR

RU

TR

INSTALLATION MANUAL

For safe and correct use, please read this installation manual thoroughly before installing the air-conditioner unit.

INSTALLATIONSHANDBUCH

Zum sicheren und ordnungsgemäßen Gebrauch der Klimageräte das Installationshandbuch gründlich durchlesen.

MANUEL D'INSTALLATION

Veillez lire le manuel d'installation en entier avant d'installer ce climatiseur pour éviter tout accident et vous assurer d'une utilisation correcte.

MANUAL DE INSTALACIÓN

Para un uso seguro y correcto, lea detalladamente este manual de instalación antes de montar la unidad de aire acondicionado.

MANUALE DI INSTALLAZIONE

Per un uso sicuro e corretto, leggere attentamente questo manuale di installazione prima di installare il condizionatore d'aria.

INSTALLATIEHANDLEIDING

Voor een veilig en juist gebruik moet u deze installatiehandleiding grondig doorlezen voordat u de airconditioner installeert.

MANUAL DE INSTALAÇÃO

Para segurança e utilização correctas, leia atentamente este manual de instalação antes de instalar a unidade de ar condicionado.

ΕΓΧΕΙΡΙΔΙΟ ΟΔΗΓΙΩΝ ΕΓΚΑΤΑΣΤΑΣΗΣ

Για ασφάλεια και σωστή χρήση, παρακαλείστε διαβάσετε προσεκτικά αυτό το εγχειρίδιο εγκατάστασης πριν αρχίσετε την εγκατάσταση της μονάδας κλιματισμού.

РУКОВОДСТВО ПО УСТАНОВКЕ

Для осторожного и правильного использования прибора необходимо тщательно ознакомиться с данным руководством по установке до выполнения установки кондиционера.

MONTAJ ELKİTABI

Emniyetli ve doğru biçimde nasıl kullanılacağını öğrenmek için lütfen klima cihazını monte etmeden önce bu elkitabını dikkatle okuyunuz.

5 [Fig. 5.0.1]

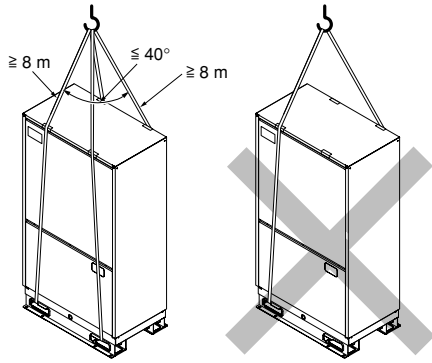

6 **6.1**

[Fig. 6.1.1]

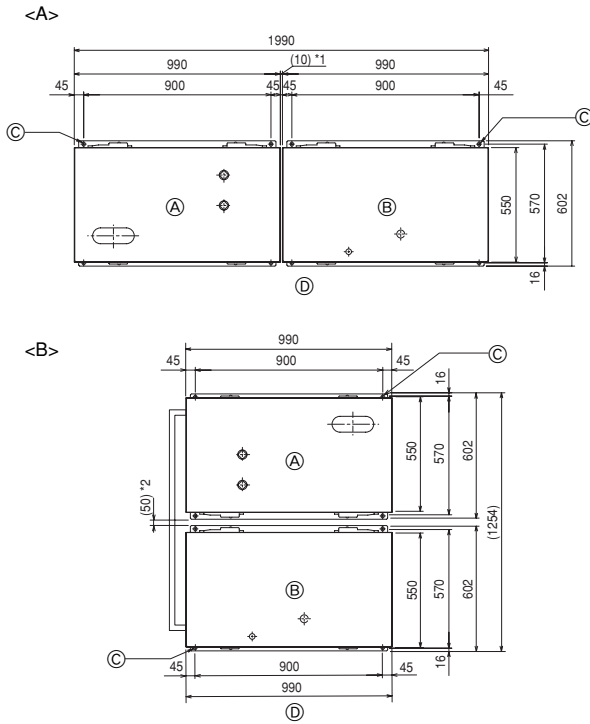

- <A> Side-by-side installation
- Back-to-back installation
- (A) Heat exchanger unit
- (B) Compressor unit
- (C) 4-ø14 (Anchoring hole)
- (D) (Top view)

- *1 Select an installation site that is level and free from vibrations so that the side panels of the units do not rub against each other.
- *2 Select an installation site that allows the fixation of the units to the floor.

[Fig. 6.1.2]

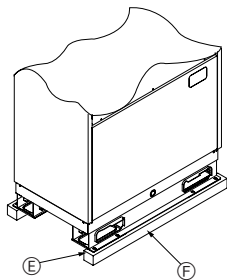

- (E) Anti-vibration pad etc.
- (F) Concrete base

6.2

[Fig. 6.2.1]

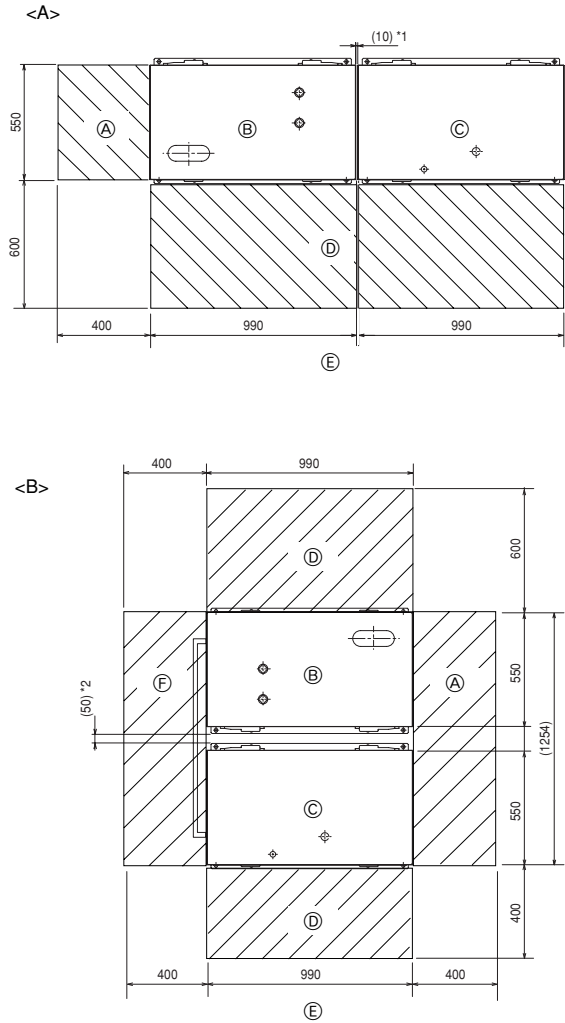

- <A> Side-by-side installation
- Back-to-back installation
- (A) Piping space (for side piping)
- (B) Heat exchanger unit
- (C) Compressor unit
- (D) Service space (front side)
- (E) (Top view)
- (F) Piping space

- *1 Select an installation site that is level and free from vibrations so that the side panels of the units do not rub against each other.
- *2 Select an installation site that allows the fixation of the units to the floor.

6.2

[Fig. 6.2.2]

- <A> Side-by-side installation
- Sample back-to-back installation

- ⓐ Piping space (for top piping)
- ⓑ Piping space (for side piping)
- ⓒ Heat exchanger unit
- ⓓ Compressor unit
- ⓔ Field-installed pipes
 - Bypass pipe $\phi 9.52$ (Flare + Brazed)
 - High press pipe $\phi 19.05$ (Flare + Brazed)
 - Low press pipe $\phi 25.4$ (Flange + Brazed)
- ⓕ Connecting wire between heat exchanger unit and compressor unit (External heater adapter*)
 - Control signal wire (connector, on-site connection)
- * If the space between the heat exchanger unit and compressor unit exceeds 1.5 m (the length of the standard supplied external heater adapter), an optional external heater adapter (available in 5m or 10m) is necessary.
- ⓖ (Front view)
- ⓗ Service space (Heat exchanger unit side)
- ⓓ Service space (Compressor unit side)
- ⓖ Piping space
- ⓗ Pipe/wire output port
- ⓓ (Side view)

*1 Select an installation site that is level and free from vibrations so that the side panels of the units do not rub against each other.

*2 Select an installation site that allows the fixation of the units to the floor.

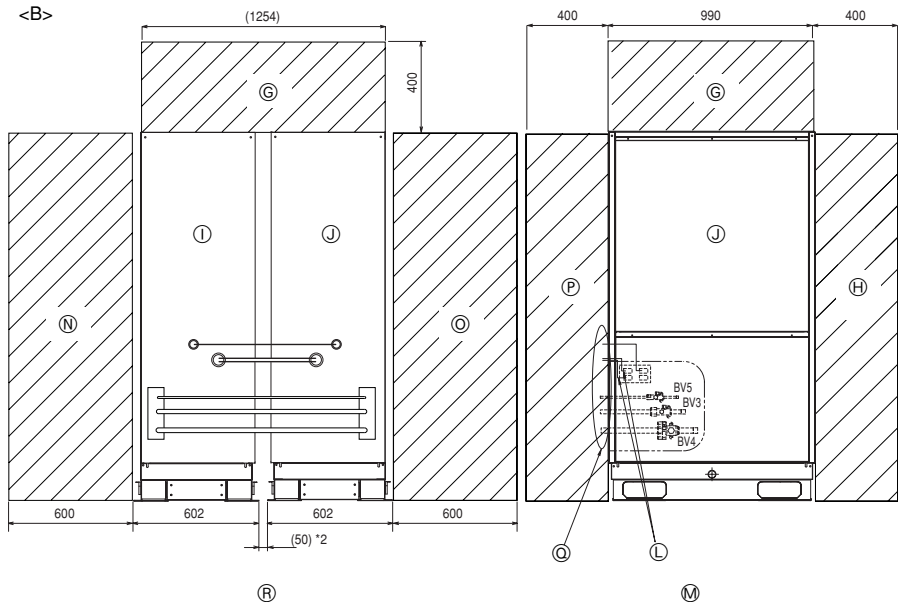
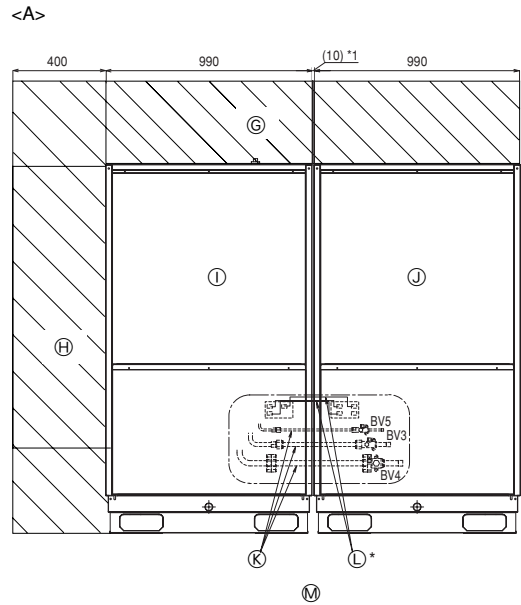

7

7.1

[Fig. 7.1.1]

Side piping

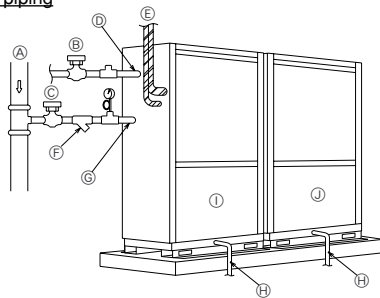

Top piping

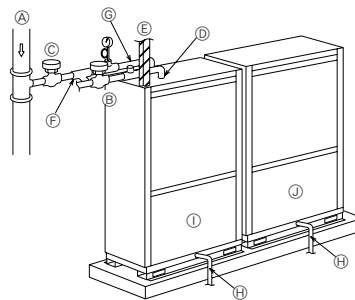

- Ⓐ Water circulation pipe
- Ⓑ Close valve
- Ⓒ Close valve
- Ⓓ Water outlet
- Ⓔ Refrigerant piping
- Ⓕ Y-type strainer
- Ⓖ Water inlet
- Ⓗ Drain pipe
- Ⓘ Heat exchanger unit
- Ⓝ Compressor unit

7.4

[Fig. 7.4.1]



- Ⓐ Short-circuit wire (Connected before delivery from manufacturer)
- Ⓑ Pump interlock circuit connection

[Fig. 8.2.1]

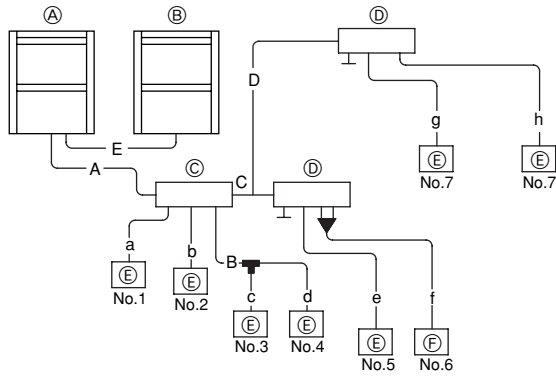

- Ⓐ Heat exchanger unit
- Ⓑ Compressor unit
- Ⓒ BC controller (main)
- Ⓓ BC controller (sub)
- Ⓔ indoor unit (20 ~ 140)
- Ⓕ indoor unit (200, 250)

C, D (mm)

	Ⓔ High press. gas pipe	Ⓕ Low press. gas pipe	Ⓖ Liquid pipe
~ 200	ø15.88	ø19.05	ø9.52
201 ~ 300	ø19.05	ø22.2	ø12.7
301 ~ 350	ø19.05	ø28.58	ø12.7

E (mm)

Ⓙ High press pipe	Ⓚ Low press pipe	Ⓛ Bypass pipe
ø19.05	ø28.58	ø9.52

a, b, c, d, e, f, g, h (mm)

Ⓜ Model number	Ⓔ Liquid line	Ⓕ Gas line
20,25,32,40,50	ø6.35	ø12.7
63,71,80,100,125,140	ø9.52	ø15.88
200	ø9.52	ø19.05
250	ø9.52	ø22.2

A (mm)

Ⓐ Heat source model	Ⓑ High press. side	Ⓒ Low press. side
P400	ø22.2	ø28.58
P500	ø22.2	ø28.58

B (mm)

Ⓓ Total capacity of indoor units	Ⓔ Liquid line	Ⓕ Gas line
~ 140	ø9.52	ø15.88
141 ~ 200	ø9.52	ø19.05

[Fig. 9.2.1]

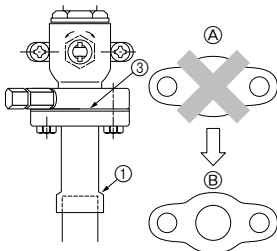

- Ⓐ Close-packed packing
- Ⓑ Hollow packing

[Fig. 9.2.2]

<A> [Ball valve (Low press. side/flanged type)] [Ball valve (High press. side/flanged type)]

<C> This figure shows the valve in the fully open state.

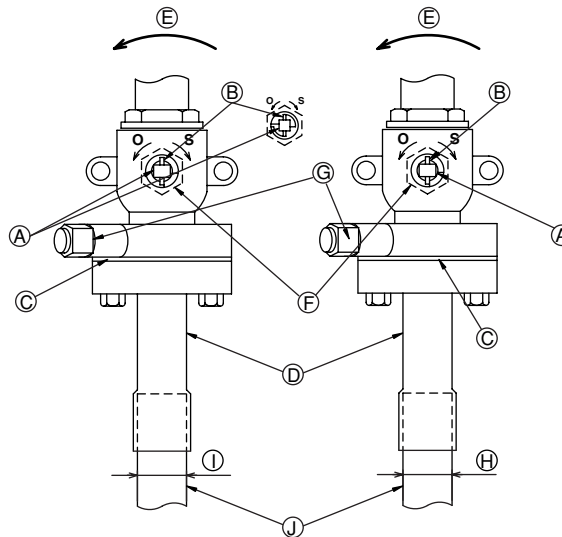

- Ⓐ Valve stem
- Ⓑ Stopper pin
- Ⓒ Packing (Accessory)
- Ⓓ Connecting pipe (Accessory)
- Ⓔ Open (Operate slowly)
- Ⓕ Cap
- Ⓖ Service port
- Ⓗ ø22.2 (PQRY-P400)
- Ⓗ ø22.2 (PQRY-P500)
- Ⓛ ø28.58 (PQRY-P400)
- Ⓛ ø28.58 (PQRY-P500)
- Ⓜ Field piping

[Fig. 9.2.3]

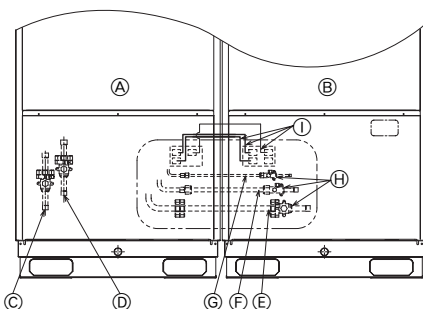

- Ⓐ Heat exchanger unit
- Ⓑ Compressor unit
- Ⓒ Low press pipe (BC controller side ø28.58)
- Ⓓ High press pipe (BC controller side ø22.2)
- Ⓔ Heat exchanger unit – Compressor unit connection pipe (ø28.58 Flange + Brazed)
- Ⓕ Heat exchanger unit – Compressor unit connection pipe (ø19.05 Flare + Brazed)
- Ⓖ Heat exchanger unit – Compressor unit connection pipe (ø9.52 Flare + Brazed)
- Ⓗ Ball valve
- Ⓛ External heater adapter (3-wire)

[Fig. 9.2.4]

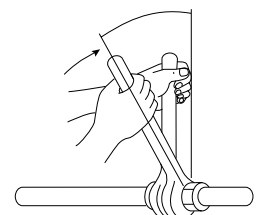

9.3

[Fig. 9.3.1]

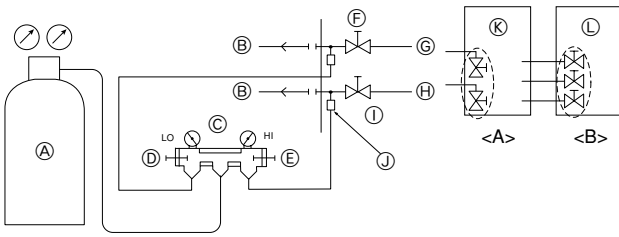

- | | | |
|---------------------|-------------------------|------------|
| (A) Nitrogen gas | (G) Low press. pipe | <A> Open |
| (B) To indoor unit | (H) High press. pipe | Closed |
| (C) System analyzer | (I) Heat source unit | |
| (D) Lo knob | (J) Service port | |
| (E) Hi knob | (K) Heat exchanger unit | |
| (F) Ball valve | (L) Compressor unit | |

[Fig. 9.3.2]

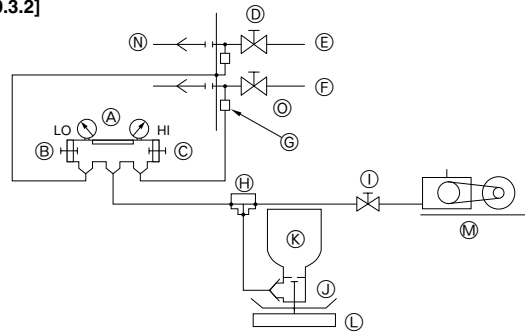

- | | |
|-------------------------------------------|----------------------|
| (A) System analyzer | (J) Valve |
| (B) Lo knob | (K) R410A cylinder |
| (C) Hi knob | (L) Scale |
| (D) Ball valve (Heat exchanger unit side) | (M) Vacuum pump |
| (E) Low press. pipe | (N) To indoor unit |
| (F) High press. pipe | (O) Heat source unit |
| (G) Service port | |
| (H) Three-way joint | |
| (I) Valve | |

[Fig. 9.3.3]

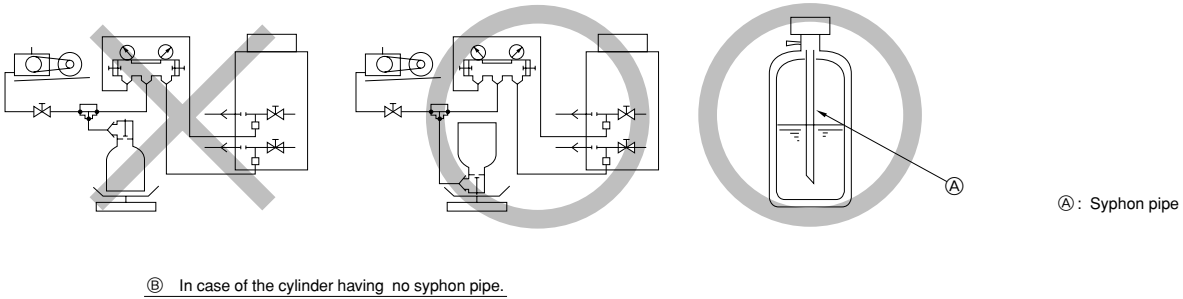

9.4

[Fig. 9.4.1]

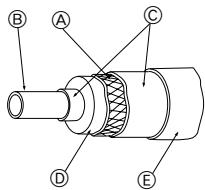

- | |
|--------------------------------------|
| (A) Steel wire |
| (B) Piping |
| (C) Asphaltic oily mastic or asphalt |
| (D) Heat insulation material A |
| (E) Outer covering B |

[Fig. 9.4.2]

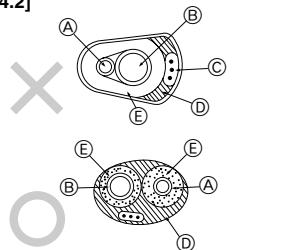

- | | |
|----------------------|--------------------|
| (A) High press. pipe | (D) Finishing tape |
| (B) Low press. pipe | (E) Insulator |
| (C) Electric wire | |

[Fig. 9.4.3]

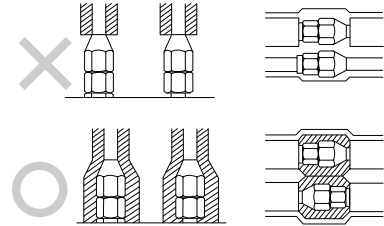

[Fig. 9.4.4]

<A> Inner wall (concealed) Outer wall <C> Outer wall (exposed) <D> Floor (waterproofing) <E> Roof pipe shaft <F> Penetrating portion on fire limit and boundary wall

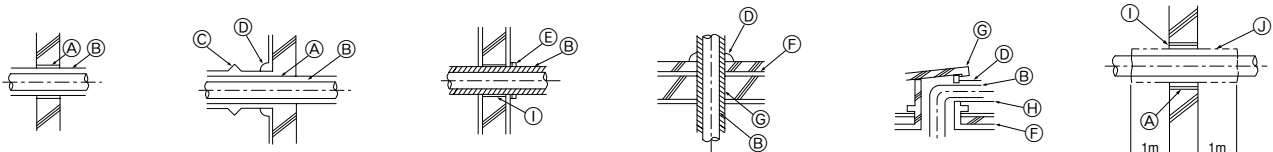

- | | |
|------------------------------|--------------------------------------------|
| (A) Sleeve | (G) Sleeve with edge |
| (B) Heat insulating material | (H) Lagging material |
| (C) Lagging | (I) Mortar or other incombustible caulking |
| (D) Caulking material | (J) Incombustible heat insulation material |
| (E) Band | |
| (F) Waterproofing layer | |

[Fig. 10.2.1]

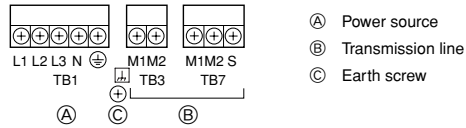

- (A) Power source
- (B) Transmission line
- (C) Earth screw

[Fig. 10.2.2]

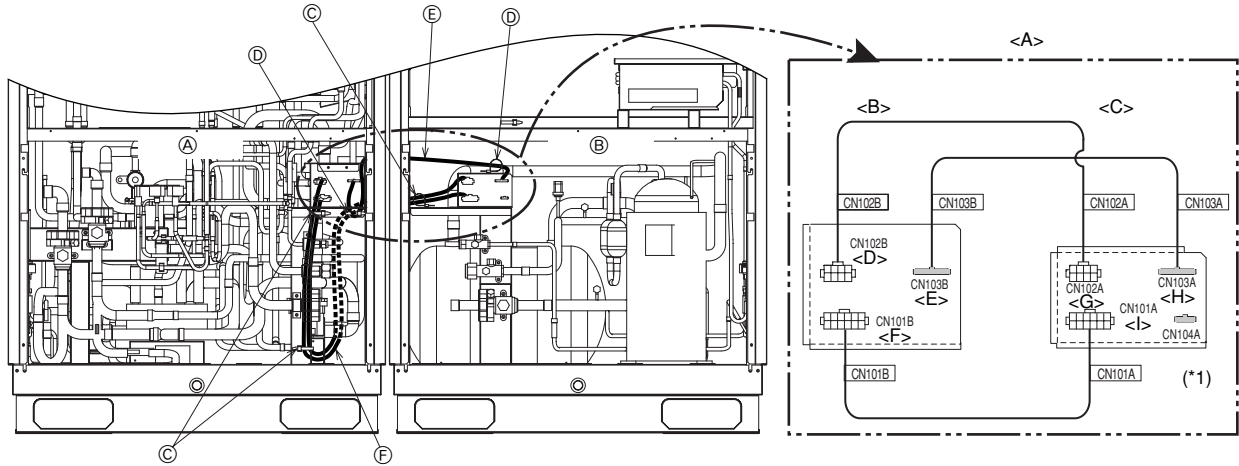

- (A) Heat exchanger unit
- (B) Compressor unit
- (C) Cable clamp (power supply line)
- (D) Cable clamp (control line)
- (E) Control cable
- (F) Power supply cable

- <A> Enlarged view of connector section
- Heat exchanger unit side
- <C> Compressor unit side
- <D> CN102B (For power supply line)
- <E> CN103B (For control line)
- <F> CN101B (For power supply line)
- <G> CN102A (For power supply line)
- <H> CN103A (For control line)
- <I> CN101A (For power supply line)
- *1 CN104A is not used for the WR2 models.

[Fig. 10.2.3]

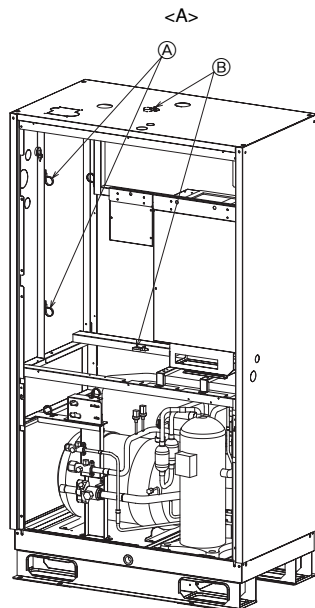

- <A> Compressor unit
- (A) Cable clamp for power supply cable
- (B) Cable clamp for transmission cable

10.3

[Fig. 10.3.1]

- <A> Change the jumper connector from CN41 to CN40
 - SW2-1:ON
-
- <C> Keep the jumper connector on CN41
 - SW2-1:ON

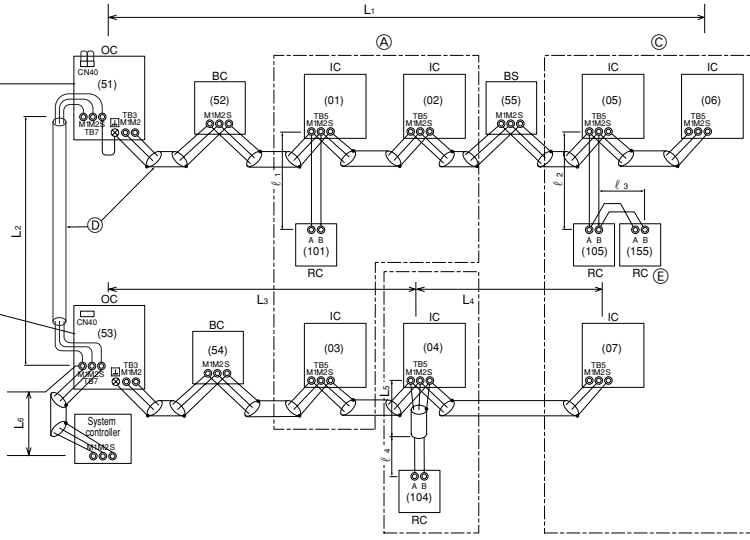

[Fig. 10.3.2]

- <A> Change the jumper connector from CN41 to CN40
 - SW2-1:ON
-
- <C> Keep the jumper connector on CN41
 - SW2-1:ON

- (A) Group 1
- (B) Group 4
- (C) Group 5
- (D) Shielded wire
- (E) Sub remote controller
- (): Address

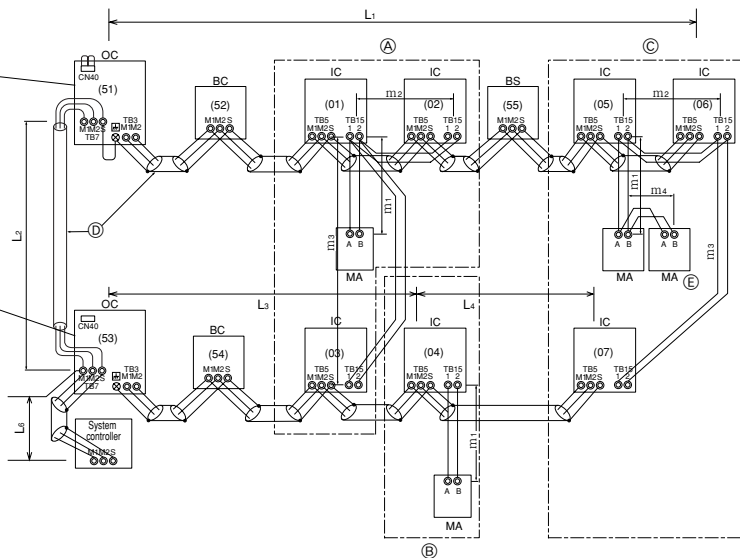

[Fig. 10.3.3]

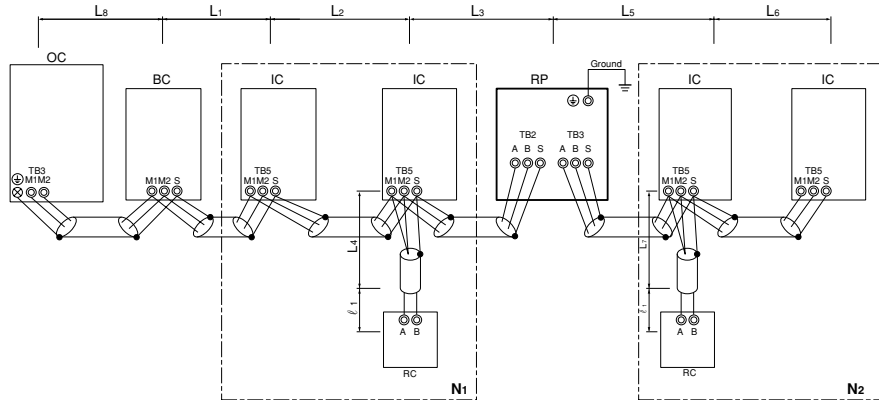

10.4

[Fig. 10.4.1]

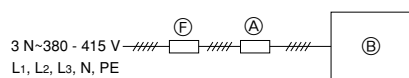

- (A) Switch (breakers for wiring and current leakage)
- (B) Heat source unit (Compressor unit side)
- (C) BC controller (main)
- (C') BC controller (sub)
- (D) Pull box
- (E) Indoor unit
- (F) Breakers for current leakage

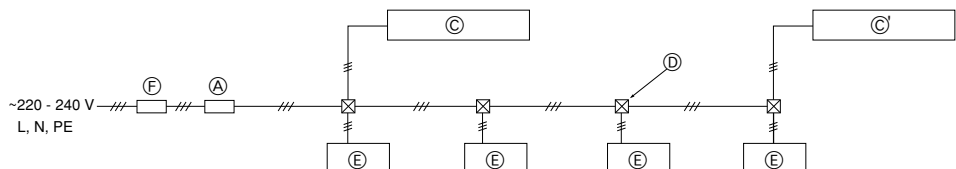

1. Safety precautions	8	8. Refrigerant piping installation	12
1.1. Before installation and electric work	8	8.1. Caution	12
1.2. Precautions for devices that use R410A refrigerant	8	8.2. Refrigerant piping system	12
1.3. Before getting installed	9	9. Additional refrigerant charge	12
1.4. Before installation electrical work	9	9.1. Calculation of additional refrigerant charge	12
1.5. Before starting the test run	9	9.2. Precautions concerning piping connection and valve operation	13
2. About the product	9	9.3. Airtight test, evacuation, and refrigerant charging	14
3. Specifications	9	9.4. Thermal insulation of refrigerant piping	14
4. Confirmation of parts attached	10	10. Wiring	15
5. Lifting method	10	10.1. Caution	15
6. Installation of unit and service space	10	10.2. Control box and connecting position of wiring	15
6.1. Installation	10	10.3. Wiring transmission cables	16
6.2. Service space	10	10.4. Wiring of main power supply and equipment capacity	17
7. Water pipe installation	11	11. Test run	18
7.1. Precautions during installation	11	11.1. The following phenomena do not represent trouble (emergency)	18
7.2. Insulation installation	11	12. Information on rating plate	18
7.3. Water processing and water quality control	11		
7.4. Pump interlock	11		

1. Safety precautions

1.1. Before installation and electric work

- ▶ Before installing the unit, make sure you read all the “Safety precautions”.
- ▶ The “Safety precautions” provide very important points regarding safety. Make sure you follow them.

Symbols used in the text





Warning:

Describes precautions that should be observed to prevent danger of injury or death to the user.

Caution:

Describes precautions that should be observed to prevent damage to the unit.

Symbols used in the illustrations

-  : Indicates an action that must be avoided.
-  : Indicates that important instructions must be followed.
-  : Indicates a part which must be grounded.
-  : Beware of electric shock. (This symbol is displayed on the main unit label.)
<Color: yellow>

Warning:

Carefully read the labels affixed to the main unit.

Warning:

- Ask the dealer or an authorized technician to install the air conditioner.
 - Improper installation by the user may result in water leakage, electric shock, or fire.
- Install the unit in a place that can withstand its weight.
 - Inadequate strength may cause the unit to fall down, resulting in injuries.
- Use the specified cables for wiring. Make the connections securely so that the outside force of the cable is not applied to the terminals.
 - Inadequate connection and fastening may generate heat and cause a fire.
- Prepare for rain and other moisture and earthquakes and install the unit at the specified place.
 - Improper installation may cause the unit to topple over and result in injury.
- Always use an filter and other accessories specified by Mitsubishi Electric.
 - Ask an authorized technician to install the accessories. Improper installation by the user may result in water leakage, electric shock, or fire.
- Never repair the unit. If the air conditioner must be repaired, consult the dealer.
 - If the unit is repaired improperly, water leakage, electric shock, or fire may result.
- If refrigerant gas leaks during installation work, ventilate the room.
 - If the refrigerant gas comes into contact with a flame, poisonous gases will be released.
- Install the air conditioner according to this Installation Manual.
 - If the unit is installed improperly, water leakage, electric shock, or fire may result.
- Have all electric work done by a licensed electrician according to “Electric Facility Engineering Standard” and “Interior Wire Regulations” and the instructions given in this manual and always use a special circuit.

- If the power source capacity is inadequate or electric work is performed improperly, electric shock and fire may result.
- Securely install the heat source unit terminal cover (panel).
 - If the terminal cover (panel) is not installed properly, dust or water may enter the heat source unit and fire or electric shock may result.
- When installing and moving the air conditioner to another site, do not charge it with a refrigerant different from the refrigerant (R410A) specified on the unit.
 - If a different refrigerant or air is mixed with the original refrigerant, the refrigerant cycle may malfunction and the unit may be damaged.
- If the air conditioner is installed in a small room, measures must be taken to prevent the refrigerant concentration from exceeding the safety limit even if the refrigerant should leak.
 - Consult the dealer regarding the appropriate measures to prevent the safety limit from being exceeded. Should the refrigerant leak and cause the safety limit to be exceeded, hazards due to lack of oxygen in the room could result.
- When moving and reinstalling the air conditioner, consult the dealer or an authorized technician.
 - If the air conditioner is installed improperly, water leakage, electric shock, or fire may result.
- After completing installation work, make sure that refrigerant gas is not leaking.
 - If the refrigerant gas leaks and is exposed to a fan heater, stove, oven, or other heat source, it may generate noxious gases.
- Do not reconstruct or change the settings of the protection devices.
 - If the pressure switch, thermal switch, or other protection device is shorted and operated forcibly, or parts other than those specified by Mitsubishi Electric are used, fire or explosion may result.
- To dispose of this product, consult your dealer.
- The installer and system specialist shall secure safety against leakage according to local regulation or standards.
 - Following standards may be applicable if local regulation are not available.
- Pay a special attention to the place, such as a basement, etc. where refrigeration gas can stay, since refrigeration is heavier than the air.

1.2. Precautions for devices that use R410A refrigerant

Caution:

- Do not use the existing refrigerant piping.
 - The old refrigerant and refrigerator oil in the existing piping contains a large amount of chlorine which may cause the refrigerator oil of the new unit to deteriorate.
 - R410A is a high-pressure refrigerant and can cause the existing piping to burst.
- Use refrigerant piping made of phosphorus deoxidized copper and copper alloy seamless pipes and tubes. In addition, be sure that the inner and outer surfaces of the pipes are clean and free of hazardous sulphur, oxides, dust/dirt, shaving particles, oils, moisture, or any other contaminant.
 - Contaminants on the inside of the refrigerant piping may cause the refrigerant residual oil to deteriorate.
- Store the piping to be used during installation indoors and keep both ends of the piping sealed until just before brazing. (Store elbows and other joints in a plastic bag.)
 - If dust, dirt, or water enters the refrigerant cycle, deterioration of the oil and compressor trouble may result.
- Use ester oil, ether oil or alkylbenzene (small amount) as the refrigerator oil to coat flares and flange connections.
 - The refrigerator oil will degrade if it is mixed with a large amount of mineral oil.

- **Use liquid refrigerant to fill the system.**
 - If gas refrigerant is used to seal the system, the composition of the refrigerant in the cylinder will change and performance may drop.
- **Do not use a refrigerant other than R410A.**
 - If another refrigerant (R22, etc.) is mixed with R410A, the chlorine in the refrigerant may cause the refrigerator oil to deteriorate.
- **Use a vacuum pump with a reverse flow check valve.**
 - The vacuum pump oil may flow back into the refrigerant cycle and cause the refrigerator oil to deteriorate.
- **Do not use the following tools that are used with conventional refrigerants.**

(Gauge manifold, charge hose, gas leak detector, reverse flow check valve, refrigerant charge base, refrigerant recovery equipment)

 - If the conventional refrigerant and refrigerator oil are mixed in the R410A, the refrigerant may deteriorate.
 - If water is mixed in the R410A, the refrigerator oil may deteriorate.
 - Since R410A does not contain any chlorine, gas leak detectors for conventional refrigerants will not react to it.
- **Do not use a charging cylinder.**
 - Using a charging cylinder may cause the refrigerant to deteriorate.
- **Be especially careful when managing the tools.**
 - If dust, dirt, or water gets in the refrigerant cycle, the refrigerant may deteriorate.

1.3. Before getting installed

⚠ Caution:

- **Do not install the unit where combustible gas may leak.**
 - If the gas leaks and accumulates around the unit, an explosion may result.
- **Do not use the air conditioner where food, pets, plants, precision instruments, or artwork are kept.**
 - The quality of the food, etc. may deteriorate.
- **Do not use the air conditioner in special environments.**
 - Oil, steam, sulfuric smoke, etc. can significantly reduce the performance of the air conditioner or damage its parts.
- **When installing the unit in a hospital, communication station, or similar place, provide sufficient protection against noise.**
 - The inverter equipment, private power generator, high-frequency medical equipment, or radio communication equipment may cause the air conditioner to operate erroneously, or fail to operate. On the other hand, the air conditioner may affect such equipment by creating noise that disturbs medical treatment or image broadcasting.
- **Do not install the unit on a structure that may cause leakage.**
 - When the room humidity exceeds 80 % or when the drain pipe is clogged, condensation may drip from the indoor unit. Perform collective drainage work together with the heat source unit, as required.

1.4. Before installation electrical work

⚠ Caution:

- **Ground the unit.**
 - Do not connect the ground wire to gas or water pipes, lightning rods, or telephone ground lines. Improper grounding may result in electric shock.
- **The reverse phase of L lines (L1, L2, L3) can be detected (Error cord: 4103), but the reverse phase of L lines and N line can be not be detected.**
 - The some electric parts should be damaged when power is supplied under the miss wiring.

2. About the product

- This unit uses R410A-type refrigerant
- Piping for systems using R410A may be different from that for systems using conventional refrigerant because the design pressure in systems using R410A is higher. Refer to Data Book for more information.
- Some of the tools and equipment used for installation with systems that use other types of refrigerant cannot be used with the systems using R410A. Refer to Data Book for more information.

3. Specifications

Model	PQRY-P400YSGM-A		PQRY-P500YSGM-A	
Noise level	50 dB <A>		53 dB <A>	
Net weight	Compressor unit	PQY-P01YGM-A: 208 kg		
	Heat exchanger unit	PQRY-P400YGM-A: 232 kg	PQRY-P500YGM-A: 236 kg	
Allowable pressure	HP: 4.15 MPa, LP: 2.21 MPa			
Refrigerant (Compressor unit side only)	R410A: 12.0 kg			
Indoor units	Total capacity	50 ~ 150 %		
	Model / Quantity	P20 ~ P250 / 1 ~ 24	P20 ~ P250 / 1 ~ 24	
Operation temperature	Water temperature: 10°C ~ 45°C Note.1			

Note 1. When the total capacity of indoor units exceeds 130% of heat source units capacity, the operating temperature range of circulating water is 15°C ~ 45°C

- **Install the power cable so that tension is not applied to the cable.**
 - Tension may cause the cable to break and generate heat and cause a fire.
- **Install a leak circuit breaker, as required.**
 - If a leak circuit breaker is not installed, electric shock may result.
- **Use power line cables of sufficient current carrying capacity and rating.**
 - Cables that are too small may leak, generate heat, and cause a fire.
- **Use only a circuit breaker and fuse of the specified capacity.**
 - A fuse or circuit breaker of a larger capacity or a steel or copper wire may result in a general unit failure or fire.
- **Do not wash the air conditioner units.**
 - Washing them may cause an electric shock.
- **Be careful that the installation base is not damaged by long use.**
 - If the damage is left uncorrected, the unit may fall and cause personal injury or property damage.
- **Install the drain piping according to this Installation Manual to ensure proper drainage. Wrap thermal insulation around the pipes to prevent condensation.**
 - Improper drain piping may cause water leakage and damage to furniture and other possessions.
- **Be very careful about product transportation.**
 - Only one person should not carry the product if it weighs more than 20 kg.
 - Some products use PP bands for packaging. Do not use any PP bands for a means of transportation. It is dangerous.
 - When transporting the heat source unit, support it at the specified positions on the unit base. Also support the heat source unit at four points so that it cannot slip side ways.
- **Safely dispose of the packing materials.**
 - Packing materials, such as nails and other metal or wooden parts, may cause stabs or other injuries.
 - Tear apart and throw away plastic packaging bags so that children will not play with them. If children play with a plastic bag which was not torn apart, they face the risk of suffocation.

1.5. Before starting the test run

⚠ Caution:

- **Turn on the power at least 12 hours before starting operation.**
 - Starting operation immediately after turning on the main power switch can result in severe damage to internal parts. Keep the power switch turned on during the operational season.
- **Do not touch the switches with wet fingers.**
 - Touching a switch with wet fingers can cause electric shock.
- **Do not touch the refrigerant pipes during and immediately after operation.**
 - During and immediately after operation, the refrigerant pipes are may be hot and may be cold, depending on the condition of the refrigerant flowing through the refrigerant piping, compressor, and other refrigerant cycle parts. Your hands may suffer burns or frostbite if you touch the refrigerant pipes.
- **Do not operate the air conditioner with the panels and guards removed.**
 - Rotating, hot, or high-voltage parts can cause injuries.
- **Do not turn off the power immediately after stopping operation.**
 - Always wait at least five minutes before turning off the power. Otherwise, water leakage and trouble may occur.
- **Do not touch the surface of the compressor during servicing.**
 - If unit is connected to the supply and not running, crank case heater at compressor is operating.

- Do not use the existing piping, as it contains chlorine, which is found in conventional refrigerating machine oil and refrigerant. This chlorine will deteriorate the refrigerant machine oil in the new equipment. The existing piping must not be used as the design pressure in systems using R410A is higher than that in the systems using other types of refrigerant and the existing pipes may burst.

4. Confirmation of parts attached

		① Connecting pipe for heat exchanger unit (Low press side ø28.58)	② Connecting pipe (Compressor unit - Heat exchanger unit ø28.58)	③ Connecting pipe for heat exchanger unit (High press side ø22.2)	④ Connecting pipe (Compressor unit - Heat exchanger unit ø9.52)
Model	PQY-P01YGM-A	—	1 pc. (*)	—	1 pc.
	PQRY-P400/P500YGM-A	1 pc. (*)	1 pc.	1 pc. (*)	1 pc.
		⑤ Connecting pipe (Compressor unit - Heat exchanger unit ø19.05)	⑥ Packing (inside ø23, outside ø35)	⑦ Bushing (ø27)	⑧ Bushing (ø38)
Model	PQY-P01YGM-A	1 pc.	1 pc.	1 pc.	1 pc.
	PQRY-P400/P500YGM-A	1 pc.	2 pcs.	—	—
		⑨ External heater adapter (3-wire)			
Model	PQY-P01YGM-A	1 pc.			
	PQRY-P400/P500YGM-A	—			

* Fixed with the unit

5. Lifting method

[Fig. 5.0.1] (P.2)

⚠ Caution:

Be very careful when carrying the product.

- Do not have only one person to carry product if it is more than 20 kg.
- PP bands are used to pack some products. Do not use them as a mean for transportation because they are dangerous.
- Tear plastic packaging bag and scrap it so that children cannot play with it. Otherwise plastic packaging bag may suffocate children to death.
- When carrying the heat source unit, be sure to support it at four points. Carrying with 3-point support may make the heat source unit unstable, resulting in it falling.

6. Installation of unit and service space

6.1. Installation

- Using the anchoring holes shown below, firmly bolt the unit to the base.

[Fig. 6.1.1] (P.2)

- <A> Side-by-side installation
- Back-to-back installation

- Ⓐ Heat exchanger unit Ⓑ Compressor unit
- Ⓒ 4-ø14 (Anchoring hole) Ⓓ (Top view)

*1 Select an installation site that is level and free from vibrations so that the side panels of the units do not rub against each other.

*2 Select an installation site that allows the fixation of the units to the floor.

Bases and anti-vibration

- Be sure to install unit in a place strong enough to withstand its weight. If the base is unstable, reinforce with a concrete base.
- The unit must be anchored on a level surface. Use a level to check after installation.
- Anti-vibration pads must be placed under the base of the unit.
- If the unit is installed near a room where noise is a problem, using an anti-vibration stand on the base of the unit is recommended.

[Fig. 6.1.2] (P.2)

- Ⓔ Anti-vibration pad etc.
- Ⓕ Concrete base

⚠ Warning:

- **Be sure to install unit in a place strong enough to withstand its weight. Any lack of strength may cause unit to fall down, resulting in a personal injury.**
- **Have installation work in order to protect against earthquake. Any installation deficiency may cause unit to fall down, resulting in a personal injury.**
- **In the case of a side-by-side installation of a compressor unit and a heat exchanger unit, leave a space of at least 10mm between them. When they are installed too closely together, they may rub against each other and generate noise.**
- **In the case of a back-to-back installation of a compressor unit and a heat exchanger unit, leave a space of at least 50mm between them. If they are installed too closely together, there may not be enough space for using the tools to anchor the units to the base.**

6.2. Service space

- Please allow for the following service spaces after installation. (All servicing can be performed from the front of the unit)

[Fig. 6.2.1] (P.2)

- <A> Side-by-side installation
- Back-to-back installation
- Ⓐ Piping space (for side piping)
- Ⓑ Heat exchanger unit
- Ⓒ Compressor unit
- Ⓓ Service space (front side)
- Ⓔ (Top view)
- Ⓕ Piping space

*1 Select an installation site that is level and free from vibrations so that the side panels of the units do not rub against each other.

*2 Select an installation site that allows the fixation of the units to the floor.

[Fig. 6.2.2] (P.3)

- <A> Side-by-side installation
- Sample back-to-back installation
- Ⓒ Piping space (for top piping)
- Ⓓ Piping space (for side piping)
- Ⓐ Heat exchanger unit
- Ⓑ Compressor unit
- Ⓖ Field-installed pipes
 - Bypass pipe ø9.52 (Flare + Brazed)
 - High press pipe ø19.05 (Flare + Brazed)
 - Low press pipe ø25.4 (Flange + Brazed)
- Ⓒ Connecting wire between heat exchanger unit and compressor unit (External heater adapter*)
 - Control signal wire (connector, on-site connection)
- * If the space between the heat exchanger unit and compressor unit exceeds 1.5 m (the length of the standard supplied external heater adapter), an optional external heater adapter (available in 5m or 10m) is necessary.
- Ⓜ (Front view)
- Ⓝ Service space (Heat exchanger unit side)
- Ⓞ Service space (Compressor unit side)
- Ⓟ Piping space
- Ⓠ Pipe/wire output port
- Ⓡ (Side view)

*1 Select an installation site that is level and free from vibrations so that the side panels of the units do not rub against each other.

*2 Select an installation site that allows the fixation of the units to the floor.

7. Water pipe installation

- City Multi WR2 Series pipes are similar to other air-conditioning pipes, however, please observe the following precautions during installation.

7.1. Precautions during installation

- Use the reverse-return method to insure proper pipe resistance to each unit.
- To insure easy maintenance, inspection, and replacement of the unit, use a proper joint, valve, etc. on the water intake and outlet port. In addition, be sure to install a strainer on the water intake pipe. (In order to maintain the heat source unit, a strainer on the circulating water inlet is necessary.)
* An example of the heat source unit installation is shown in the diagram below.
- Install a suitable air vent on the water pipe. After sending water through the pipe, be sure to vent the excess air.
- Compressed water may form in the low-temperature sections of heat source unit. Use a drainage pipe connected to the drain valve at the base of the unit to drain the water.
- There is a water vent plug in the center of the heat exchanger water inlet head at the middle of the unit. Use this for maintenance, etc.
In addition, do not allow any of the unit's electrical parts (such as the solenoid valve coil or compressor power supply) to become wet.
- Install a back flow-prevention valve on the pump and a flexible joint to prevent excess vibration.
- Use a sleeve to protect the pipes where they go through a wall.
- Use metal fittings to secure the pipes, and install them so that they have maximum protection against breakage and bending.
- Do not confuse the water intake and outlet valves.
- This unit doesn't have any heater to prevent freezing within tubes. When the water flow is stopped on low ambient, take out the water from tubes.
- The unused knockout holes should be closed and the opening of refrigerant pipes, water pipes, power source and transmission wires should be filled with putty and so on to prevent from rain. (field construction)

Example of heat source unit installation (using left piping)

[Fig. 7.1.1] (P.3)

- | | |
|--------------------------|-------------------|
| Ⓐ Water circulation pipe | Ⓑ Close valve |
| Ⓒ Close valve | Ⓓ Water outlet |
| Ⓔ Refrigerant piping | Ⓕ Y-type strainer |
| Ⓖ Water inlet | Ⓗ Drain pipe |
| Ⓘ Heat exchanger unit | Ⓖ Compressor unit |

7.2. Insulation installation

With City Multi WR2 Series piping, as long as the temperature range of the circulating water is kept to average temperatures year-round (30°C in the summer, 20°C in the winter), there is no need to insulate or otherwise protect indoor piping from exposure. You should use insulation in the following situations:

- Any heat source piping.
- Indoor piping in cold-weather regions where frozen pipes are a problem.
- When air coming from the outside causes condensation to form on piping.
- Any drainage piping.

7.3. Water processing and water quality control

To preserve water quality, use the closed type of cooling tower for WR2. When the circulating water quality is poor, the water heat exchanger can develop scales, leading to a reduction in heat-exchange power and possible corrosion of the heat exchanger. Please pay careful attention to water processing and water quality control when installing the water circulation system.

- Removal of foreign objects or impurities within the pipes.
During installation, be careful that foreign objects, such as welding fragments,

sealant particles, or rust, do not enter the pipes.

Water Quality Processing

- ① Depending on the quality of the cold-temperature water used in the air-conditioner, the copper piping of the heat exchanger may become corroded. We recommend regular water quality processing.
Cold water circulation systems using open heat storage tanks are particularly prone to corrosion.

When using an open-type heat storage tank, install a water-to-water heat exchanger, and use a closed-loop circuit on the air conditioner side. If a water supply tank is installed, keep contact with air to a minimum, and keep the level of dissolved oxygen in the water no higher than 1mg/ℓ.

② Water quality standard

Items	Lower mid-range temperature water system		Tendency		
	Recirculating water (20<T≤60°C)	Make-up water	Corrosive	Scale-forming	
Standard items	pH (25°C)	7.0 ~ 8.0	7.0 ~ 8.0	○	○
	Electric conductivity (mS/m) (25°C) (μs/cm) (25°C)	30 or less [300 or less]	30 or less [300 or less]	○	○
	Chloride ion (mg Cl/ℓ)	50 or less	50 or less	○	
	Sulfate ion (mg SO ₄ ²⁻ /ℓ)	50 or less	50 or less	○	
	Acid consumption (pH4.8) (mg CaCO ₃ /ℓ)	50 or less	50 or less		○
	Total hardness (mg CaCO ₃ /ℓ)	70 or less	70 or less		○
	Calcium hardness (mg CaCO ₃ /ℓ)	50 or less	50 or less		○
	Ionic silica (mg SiO ₂ /ℓ)	30 or less	30 or less		○
	Reference items	Iron (mg Fe/ℓ)	1.0 or less	0.3 or less	○
Copper (mg Cu/ℓ)		1.0 or less	0.1 or less	○	
Sulfide ion (mg S ²⁻ /ℓ)		not to be detected	not to be detected	○	
Ammonium ion (mg NH ₄ ⁺ /ℓ)		0.3 or less	0.1 or less	○	
Residual chlorine (mg Cl/ℓ)		0.25 or less	0.3 or less	○	
Free carbon dioxide (mg CO ₂ /ℓ)		0.4 or less	4.0 or less	○	
Ryzner stability index	-	-	○	○	

Reference : Guideline of Water Quality for Refrigeration and Air Conditioning Equipment. (JRA GL02E-1994)

- ③ Please consult with a water quality control specialist about water quality control methods and water quality calculations before using anti-corrosive solutions for water quality management.

- ④ When replacing a previously installed air conditioning device (even when only the heat exchanger is being replaced), first conduct a water quality analysis and check for possible corrosion.

Corrosion can occur in cold-water systems even if there has been no prior signs of corrosion.

If the water quality level has dropped, please adjust water quality sufficiently before replacing the unit.

7.4. Pump interlock

The heat source unit may become damaged if it is operated with no water circulating through the pipes.

Be sure to interlock unit operation and the water-circuit pump. Use the terminal blocks for interlocking (TB8-3, 4) that can be found on the unit.

In the case of a pump interlock circuit signal connection to the TB8-3, 4, remove the short-circuit wire. Also, to prevent mistaken error detection, resulting from a poor connection, in the pressure valve 63PW, use a low maintained current of 5mA or less.

[Fig. 7.4.1] (P.3)

- | |
|--------------------------------------------------------------------|
| Ⓐ Short-circuit wire (Connected before delivery from manufacturer) |
| Ⓑ Pump interlock circuit connection |

8. Refrigerant piping installation

City Multi WR2 Series is constituted by an end branching system in which the refrigerant piping from heat source unit is branched at BC controller and connected to each indoor unit.

The connection method adapted is brazing connection for high pressure pipe and low pressure pipe between heat source unit and BC controller, and flare connection between BC controller and indoor unit. Brazing connection is employed for joint pipe set and branch pipe set.

⚠ Warning:

Always use extreme care to prevent the refrigerant gas from leaking while using fire or flame. If the refrigerant gas comes in contact with a flame from any source, such as a gas stove, it breaks down and generates a poisonous gas which can cause gas poisoning. Never weld in an unventilated room. Always conduct an inspection for gas leakage after installation of the refrigerant piping has been completed.

8.1. Caution

This unit uses refrigerant R410A. Follow the local regulations on materials and pipe thickness when selecting pipes.

- ① Use the following materials for refrigeration piping.
 - Material: Use refrigerant piping made of phosphorus deoxidized copper. In addition, be sure that the inner and outer surfaces of the pipes are clean and free of hazardous sulphur, oxides, dust/dirt, shaving particles, oils, moisture, or any other contaminant.
- ② Commercially available piping often contains dust and other materials. Always blow it clean with a dry inert gas.
- ③ Use care to prevent dust, water or other contaminants from entering the piping during installation.
- ④ Reduce the number of bending portions as much as possible, and make bending radius as big as possible.
- ⑤ Always observe the restrictions on the refrigerant piping (such as rated length, the difference between high/low pressures, and piping diameter). Failure to do so can result in equipment failure or a decline in heating/cooling performance.
- ⑥ Either a lack or an excess of refrigerant causes the unit to make an emergency stop. Charge the system with an appropriate amount of refrigerant. At such a time, always properly charge the unit. When servicing, always check the notes concerning pipe length and amount of additional refrigerant at both locations, the refrigerant volume calculation table on the back of the service panel and the additional refrigerant section on the labels for the combined number of indoor units.
- ⑦ **Use liquid refrigerant to fill the system.**
- ⑧ Never use refrigerant to perform an air purge. Always evacuate using a vacuum pump.
- ⑨ Always insulate the piping properly. Insufficient insulation will result in a decline in heating/cooling performance, water drops from condensation and other such problems.
- ⑩ When connecting the refrigerant piping, make sure the ball valve of the heat source unit is completely closed (the factory setting) and do not operate it until the refrigerant piping for the heat source and indoor units has been connected, a refrigerant leakage test has been performed and the evacuation process has been completed.

- ⑪ Residues in commercially available antioxidants may have adverse effects on the equipment. Braze only with non-oxide brazing material. The use of other brazing material may result in compressor damage. (Refer to item 9.2. for detailed information on pipe connections and valve operations.)
- ⑫ **Never perform heat source unit piping connection work when it is raining.**

⚠ Warning

When installing and moving the unit, do not charge it with refrigerant other than the refrigerant specified on the unit.

- Mixing of a different refrigerant, air, etc. may cause the refrigerant cycle to malfunction and result in severe damage.

⚠ Caution:

- **Use a vacuum pump with a reverse flow check valve.**
 - If the vacuum pump does not have a reverse flow check valve, the vacuum pump oil may flow back into the refrigerant cycle and cause deterioration of the refrigerator oil and other trouble.
- **Do not use the tools shown below used with conventional refrigerant. (Gauge manifold, charge hose, gas leak detector, check valve, refrigerant charge base, vacuum gauge, refrigerant recovery equipment)**
 - Mixing of conventional refrigerant and refrigerator oil may cause the refrigerator oil to deteriorate.
 - Mixing of water will cause the refrigerator oil to deteriorate.
 - R410A refrigerant does not contain any chlorine. Therefore, gas leak detectors for conventional refrigerants will not react to it.
- **Manage the tools more carefully than normal.**
 - If dust, dirt, or water gets in the refrigerant cycle, the refrigerator oil will deteriorate.
- **Never use existing refrigerant piping.**
 - The large amount of chlorine in conventional refrigerant and refrigerator oil in the existing piping will cause the new refrigerant to deteriorate.
- **Store the piping to be used during installation indoors and keep both ends of the piping sealed until just before brazing.**
 - If dust, dirt, or water gets into the refrigerant cycle, the oil will deteriorate and the compressor may fail.
- **Do not use a charging cylinder.**
 - Using a charging cylinder may cause the refrigerant to deteriorate.
- **Do not use special detergents for washing piping.**

8.2. Refrigerant piping system

Connection Example

[Fig. 8.2.1] (P.4)

Ⓐ Heat source model	Ⓑ High press. side
Ⓒ Low press. side	Ⓓ Total capacity of indoor units
Ⓔ Liquid line	Ⓕ Gas line
Ⓖ High press. gas pipe	Ⓗ Low press. gas pipe
Ⓗ Liquid pipe	Ⓙ High press pipe
Ⓚ Low press pipe	Ⓛ Bypass pipe
Ⓜ Model number	
Ⓐ Heat exchanger unit	Ⓑ Compressor unit
Ⓒ BC controller (main)	Ⓓ BC controller (sub)
Ⓔ indoor unit (20 ~ 140)	Ⓕ indoor unit (200, 250)

9. Additional refrigerant charge

At the time of shipping, the heat source unit is charged with the refrigerant. As this charge does not include the amount needed for extended piping, additional charging for each refrigerant line will be required on site. In order that future servicing may be properly provided, always keep a record of the size and length of each refrigerant line and the amount of additional charge by writing it in the space provided on the heat source unit.

9.1. Calculation of additional refrigerant charge

- Calculate the amount of additional charge based on the length of the piping extension and the size of the refrigerant line.
- Use the table to the below as a guide to calculating the amount of additional charging and charge the system accordingly.
- If the calculation results in a fraction of less than 0.1 kg, round up to the next 0.1 kg. For example, if the result of the calculation was 21.66 kg, round the result up to 21.7 kg.

<Additional Charge>

Additional refrigerant charge (kg)	=	High pressure pipe size Total length of $\phi 22.2 \times 0.23$ (m) $\times 0.23$ (kg/m)	+	High pressure pipe size Total length of $\phi 19.05 \times 0.16$ (m) $\times 0.16$ (kg/m)	+	High pressure pipe size Total length of $\phi 15.88 \times 0.11$ (m) $\times 0.11$ (kg/m)	+	High pressure pipe size Total length of $\phi 12.7 \times 0.12$ (m) $\times 0.12$ (kg/m)
	+	High pressure pipe size Total length of $\phi 9.52 \times 0.06$ (m) $\times 0.06$ (kg/m)	+	High pressure pipe size Total length of $\phi 6.35 \times 0.024$ (m) $\times 0.024$ (kg/m)	+	$\alpha 1 + \alpha 2 + \alpha 3$		

Outdoor: 500

Indoor	No. 1: 40	A: $\phi 22.2$	40 m	a: $\phi 6.35$	10 m	} At the conditions below:
	No. 2: 100	B: $\phi 9.52$	10 m	b: $\phi 9.52$	5 m	
	No. 3: 40	C: $\phi 12.7$	10 m	c: $\phi 6.35$	10 m	
	No. 4: 32	D: $\phi 12.7$	10 m	d: $\phi 6.35$	10 m	
	No. 5: 63			e: $\phi 9.52$	10 m	
	No. 6: 200			f: $\phi 9.52$	10 m	
	No. 7: 32			g: $\phi 6.35$	5 m	
	No. 8: 32			h: $\phi 6.35$	5 m	

The total length of each liquid line is as follows:

ø22.2: A = 40 m

ø12.7: C + D = 10 + 10 = 20 m

ø9.52: B + b + e + f = 10 + 5 + 10 + 10 = 35 m

ø6.35: a + c + d + g + h = 10 + 10 + 10 + 5 + 5 = 40 m

Therefore,

<Calculation example>

Additional refrigerant charge

= 40 × 0.23 + 20 × 0.12 + 35 × 0.06 + 40 × 0.024 + 3.0 + 2.0 + 2.0 = 21.7 kg

Value of α1

Total capacity of connecting indoor units to Model 80	α 1
Models 81 to 160	1.0 kg
Models 161 to 330	1.5 kg
Models 331 to 480	2.0 kg
Models 481 to 630	2.5 kg
Models 631 to 710	3.0 kg
Models 711 to 890	4.0 kg

Value of α2

	α 2
BC controller (main only)	0 kg
BC controller (sub) connected (one)	1.0 kg
BC controller (sub) connected (two)	2.0 kg

Value of α3

	α 3
PQRY-P400YSGM-A	0 kg
PQRY-P500YSGM-A	2.0 kg

9.2. Precautions concerning piping connection and valve operation

- The compressor unit is charged with refrigerant at factory shipment, but the heat exchanger unit is not. (The heat exchanger unit is charged with inert gas.)
- Conduct piping connection and valve operation accurately.
- Flange type side connecting pipe is assembled in factory before shipment.

- For brazing to the connecting pipe with flange, remove the connecting pipe with flange from the ball valve, and braze it outside of the unit.
- During the time when removing the connecting pipe with flange, remove the seal attached on the rear side of this sheet and paste it onto the flange surface of the ball valve to prevent the entry of dust into the valve.
- The refrigerant circuit is closed with a round, close-packed packing upon shipment to prevent gas leak between flanges. As no operation can be done under this state, be sure to replace the packing with the hollow packing attached at the piping connection.
- At the mounting of the hollow packing, wipe off dust attached on the flange sheet surface and the packing. Coat refrigerating machine oil (Ester oil, ether oil or alkylbenzene [small amount]) onto both surfaces of the packing.

[Fig. 9.2.1] (P.4)

- Ⓐ Close-packed packing
- Ⓑ Hollow packing

- After evacuation and refrigerant charge, ensure that the handle is fully open. If operating with the valve closed, abnormal pressure will be imparted to the high- or low-pressure side of the refrigerant circuit, giving damage to the compressor, four-way valve, etc.
- Determine the amount of additional refrigerant charge by using the formula, and charge refrigerant additionally through the service port after completing piping connection work.
- After completing work, tighten the service port and cap securely not to generate gas leak.
- Flare machining dimension for systems using R410A is larger than that for systems using other types of refrigerant in order to increase the air tightness.
- Refer to the table on the below for flare machining dimensions, and follow the regulations set forth by the local authorities. Seal off the opening of the pipe with a closure material (not supplied) to keep small animals from entering the pipe if that is a concern.

flare machining dimension (mm)

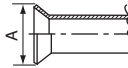

outer diameter	size in inches	dimension A
		R410A
ø6.35	1/4"	9.1
ø9.52	3/8"	13.2
ø12.70	1/2"	16.6
ø15.88	5/8"	19.7
ø19.05	3/4"	24.0

flare nut size (mm)

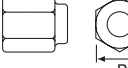

outer diameter	size in inches	dimension B
		R410A
ø6.35	1/4"	17.0
ø9.52	3/8"	22.0
ø12.70	1/2"	26.0
ø15.88	5/8"	29.0
ø19.05	3/4"	36.0

[Fig. 9.2.2] (P.4)

<A> [Ball valve (Low press. side/flanged type)]

 [Ball valve (High press. side/flanged type)]

<C> This figure shows the valve in the fully open state.

- Ⓐ Valve stem
[Fully closed at the factory, when connecting the piping, when evacuating, and when charging additional refrigerant. Open fully after the operations above are completed.]
- Ⓑ Stopper pin [Prevents the valve stem from turning 90° or more.]
- Ⓒ Packing (Accessory)
[Manufacturer: Nichiasu corporation]
[Type: T/#1991-NF]
- Ⓓ Connecting pipe (Accessory)
[Use packing and securely install this pipe to the valve flange so that gas leakage will not occur. (Tightening torque: 40 N·m) Coat both surfaces of the packing with refrigerating machine oil. (Ester oil, ether oil or alkylbenzene [small amount])]
- Ⓔ Open (Operate slowly)
- Ⓕ Cap, copper packing
[Remove the cap and operate the valve stem. Always reinstall the cap after operation is completed. (Valve stem cap tightening torque: 23 ~ 27 N·m)]
- Ⓖ Service port
[Use this port to evacuate the refrigerant piping and add an additional charge at the site.
Open and close the port using a double-ended wrench.
Always reinstall the cap after operation is completed. (Service port cap tightening torque: 12 ~ 15 N·m)]
- Ⓗ ø22.2 (PQRY-P400)
ø22.2 (PQRY-P500)
- Ⓘ ø28.58 (PQRY-P400)
ø28.58 (PQRY-P500)
- ⓵ Field piping

[Fig. 9.2.3] (P.4)

- Ⓐ Heat exchanger unit
- Ⓑ Compressor unit
- Ⓒ Low press pipe (BC controller side ø28.58)
- Ⓓ High press pipe (BC controller side ø22.2)
- Ⓔ Heat exchanger unit – Compressor unit connection pipe (ø28.58 Flange + Brazed)
- Ⓕ Heat exchanger unit – Compressor unit connection pipe (ø19.05 Flare + Brazed)
- Ⓖ Heat exchanger unit – Compressor unit connection pipe (ø9.52 Flare + Brazed)
- Ⓗ Ball valve
- Ⓘ External heater adapter (3-wire)

- Connect the pipes on the compressor unit and heat exchanger unit on site. Pipe sizes are shown below. Perform piping work according to the instructions in section 9.4 Thermal insulation of refrigerant piping.

Appropriate tightening torque by torque wrench:

Copper pipe external dia. (mm)	Tightening torque (N·m)
ø6.35	14 to 18
ø9.52	35 to 42
ø12.7	50 to 57.5
ø15.88	75 to 80
ø19.05	100 to 140

Tightening angle standard:

Pipe diameter (mm)	Tightening angle (°)
ø6.35, ø9.52	60 to 90
ø12.7, ø15.88	30 to 60
ø19.05	20 to 35

[Fig. 9.2.4] (P.4)

Note:

If a torque wrench is not available, use the following method as a standard: When you tighten the flare nut with a wrench, you will reach a point where the tightening torque will abruptly increase. Turn the flare nut beyond this point by the angle shown in the table above.

⚠ Caution:

- **Always remove the connecting pipe from the ball valve and braze it outside the unit.**
 - Brazing the connecting pipe while it is installed will heat the ball valve and cause trouble or gas leakage. The piping, etc. inside the unit may also be burned.
- **Use ester oil, ether oil or alkylbenzene (small amount) as the refrigerating machine oil to coat flares and flange connections.**
 - The refrigerating machine oil will degrade if it is mixed with a large amount of mineral oil.
- **Keep the ball valve closed until refrigerant charging to the pipes to be added on site has been completed. Opening the valve before charging the refrigerant may result in unit damage.**
- **Do not use a leak detection additive.**

9.3. Airtight test, evacuation, and refrigerant charging

① **Airtight test**

Evacuate the connecting pipes and indoor units through the service port on the ball valve of the heat exchanger unit with a vacuum pump with the ball valve on the compressor unit closed and the ball valve on the heat exchanger open as shown in the figure below. (Be sure to vacuum through the service port on both the liquid and gas pipes.)

[Fig. 9.3.1] (P.5)

- <A> Open
 Closed
- Ⓐ Nitrogen gas Ⓑ To indoor unit Ⓒ System analyzer
 - Ⓓ Lo knob Ⓔ Hi knob Ⓕ Ball valve
 - Ⓖ Low press. pipe Ⓖ High press. pipe Ⓖ Heat source unit
 - Ⓙ Service port Ⓚ Heat exchanger unit Ⓛ Compressor unit

Observe the following restrictions when conducting an air tightness test to prevent negative effects on the refrigerating machine oil. Also, with nonazeotropic refrigerant (R410A), gas leakage causes the composition to change and affects performance. Therefore, perform the airtightness test cautiously.

Airtight test procedure	Restriction
<p>1. Nitrogen gas pressurization</p> <p>(1) After pressurizing to the design pressure (4.15 MPa) using nitrogen gas, allow it to stand for about one day. If the pressure does not drop, airtightness is good. However, if the pressure drops, since the leaking point is unknown, the following bubble test may also be performed.</p> <p>(2) After the pressurization described above, spray the flare connection parts, brazed parts, flanges, and other parts that may leak with a bubbling agent (Kyuboflex, etc.) and visually check for bubbles.</p> <p>(3) After the airtight test, wipe off the bubbling agent.</p>	<ul style="list-style-type: none"> • If a flammable gas or air (oxygen) is used as the pressurization gas, it may catch fire or explode.
<p>2. Pressurization using refrigerant gas and nitrogen gas</p> <p>(1) Pressurizing to a gas pressure of approximately 0.2 MPa, pressurize to the design pressure (4.15 MPa) using nitrogen gas. However, do not pressurize at one time. Stop during pressurization and check that the pressure does not drop.</p> <p>(2) Check for gas leaks by checking the flare connection parts, brazed parts, flanges, and other parts which may leak using an R410A compatible electric leak detector.</p> <p>(3) This test may be used together with the bubble type gas leak test.</p>	<ul style="list-style-type: none"> • Do not use a refrigerant other than that indicated on the unit. • Sealing with gas from a cylinder will cause the composition of the refrigerant in the cylinder to change. • Use a pressure gauge, charging hose, and other parts especially for R410A. • An electric leak detector for R22 cannot detect leaks of R410A. • Do not use a haloid torch. (Leaks cannot be detected.)

⚠ Caution:

Only use refrigerant R410A.

- The use of other refrigerant such as R22 or R407C, which contains chlorine, will deteriorate the refrigerating machine oil or cause the compressor to malfunction.

② **Evacuation**

Evacuate with the ball valve of the heat source unit closed and evacuate both the connection piping and the indoor unit from the service port provided on the ball valve of the heat source unit using a vacuum pump. (Always evacuate from the service port of both the high press pipe and the low press pipe.) After the vacuum reaches 650 Pa [abs], continue evacuation for at least one hour or more.

* Never perform air purging using refrigerant.

[Fig. 9.3.2] (P.5)

- Ⓐ System analyzer Ⓑ Lo knob Ⓒ Hi knob
- Ⓓ Ball valve (Heat exchanger unit side) Ⓔ Low press. pipe
- Ⓕ High press. pipe Ⓖ Service port Ⓖ Three-way joint
- Ⓙ Valve Ⓚ Valve Ⓚ R410A cylinder
- Ⓛ Scale Ⓛ Vacuum pump Ⓛ To indoor unit
- Ⓛ Heat source unit

Note:

- **Always add an appropriate amount of refrigerant. Also always seal the system with liquid refrigerant. Too much or too little refrigerant will cause trouble.**
- **Use a gauge manifold, charging hose, and other parts for the refrigerant indicated on the unit.**
- **Use a gravimeter. (One that can measure down to 0.1 kg.)**
- **Use a vacuum pump with a reverse flow check valve. (Recommended vacuum gauge: ROBINAIR 14830A Thermistor Vacuum Gauge)**
Also use a vacuum gauge that reaches 65 Pa [abs] or below after operating for five minutes.

③ **Refrigerant Charging**

Since the refrigerant used with the unit is nonazeotropic, it must be charged in the liquid state. Consequently, when charging the unit with refrigerant from a cylinder, if the cylinder does not have a syphon pipe, charge the liquid refrigerant by turning the cylinder upside-down as shown in Fig.9.3.3. If the cylinder has a syphon pipe like that shown in the picture on the right, the liquid refrigerant can be charged with the cylinder standing upright. Therefore, give careful attention to the cylinder specifications. If the unit should be charged with gas refrigerant, replace all the refrigerant with new refrigerant. Do not use the refrigerant remaining in the cylinder.

[Fig. 9.3.3] (P.5)

- Ⓐ Syphon pipe Ⓑ In case of the cylinder having no syphon pipe.

9.4. Thermal insulation of refrigerant piping

Be sure to give insulation work to refrigerant piping by covering high press. (liquid) pipe and low press. (gas) pipe separately with enough thickness heat-resistant polyethylene, so that no gap is observed in the joint between indoor unit and insulating material, and insulating materials themselves. When insulation work is insufficient, there is a possibility of condensation drip, etc. Pay special attention to insulation work to ceiling plenum.

[Fig. 9.4.1] (P.5)

- Ⓐ Steel wire Ⓑ Piping
- Ⓒ Asphaltic oily mastic or asphalt Ⓓ Heat insulation material A
- Ⓔ Outer covering B

Heat insulation material A	Glass fiber + Steel wire	
	Adhesive + Heat - resistant polyethylene foam + Adhesive tape	
Outer covering B	Indoor	Vinyl tape
	Floor exposed	Water-proof hemp cloth + Bronze asphalt
	Heat source	Water-proof hemp cloth + Zinc plate + Oily paint

Note:

- **When using polyethylene cover as covering material, asphalt roofing shall not be required.**
- **No heat insulation must be provided for electric wires.**

[Fig. 9.4.2] (P.5)

- Ⓐ High press. pipe Ⓑ Low press. pipe Ⓒ Electric wire
- Ⓓ Finishing tape Ⓔ Insulator

[Fig. 9.4.3] (P.5)

Penetrations

[Fig. 9.4.4] (P.5)

- <A> Inner wall (concealed) Outer wall
- <C> Outer wall (exposed) <D> Floor (waterproofing)
- <E> Roof pipe shaft
- <F> Penetrating portion on fire limit and boundary wall
- Ⓐ Sleeve Ⓑ Heat insulating material
- Ⓒ Lagging Ⓓ Caulking material
- Ⓔ Band Ⓕ Waterproofing laye
- Ⓖ Sleeve with edge Ⓖ Lagging material
- ① Mortar or other incombustible caulking
- ② Incombustible heat insulation material

When filling a gap with mortar, cover the penetration part with steel plate so that the insulation material will not be caved in. For this part, use incombustible materials for both insulation and covering. (Vinyl covering should not be used.)

- Insulation materials for the pipes to be added on site must meet the following specifications:

	Pipe size	
	ø6.35 ~ 25.4 mm	ø28.58 ~ 38.1 mm
Thickness	10 mm min.	15 mm min.
Temperature Resistance	100 °C min.	

- * Installation of pipes in a high-temperature high-humidity environment, such as the top floor of a building, may require the use of insulation materials thicker than the ones specified in the chart above.
- * When certain specifications presented by the client must be met, ensure that they also meet the specifications on the chart above.

10. Wiring

10.1. Caution

- ① Follow ordinance of your governmental organization for technical standard related to electrical equipment, wiring regulations and guidance of each electric power company.
- ② Wiring for control (hereinafter referred to as transmission line) shall be (5 cm or more) apart from power source wiring so that it is not influenced by electric noise from power source wiring. (Do not insert transmission line and power source wire in the same conduit.)
- ③ Be sure to provide designated grounding work to heat source unit.
- ④ Give some allowance to wiring for electrical part box of indoor and heat source units, because the box is sometimes removed at the time of service work.
- ⑤ Never connect the main power source to terminal block of transmission line. If connected, electrical parts will be burnt out.
- ⑥ Use 2-core shield cable for transmission line. If transmission lines of different systems are wired with the same multicore cable, the resultant poor transmitting and receiving will cause erroneous operations.
- ⑦ Only the transmission line specified should be connected to the terminal block for heat source unit transmission.
(Transmission line to be connected with indoor unit : Terminal block TB3 for transmission line, Other : Terminal block TB7 for centralized control)
Erroneous connection does not allow the system to operate.
- ⑧ In the case of connecting with an upper class controller or to conduct group operation in different refrigerant systems, the control line for transmission is required between the heat source units.
Connect this control line between the terminal blocks for centralized control. (2-wire line with no polarity)
When conducting group operation in different refrigerant systems without connecting to the upper class controller, replace the insertion of the short circuit connector from CN41 of one heat source unit to CN40.
- ⑨ Group is set by operating the remote controller.

3. Conduit mounting plates (ø27) are being provided. Pass the power supply and transmission wires through the appropriate knock-out holes, then remove the knock-out piece from the bottom of the terminal box and connect the wires.
4. Fix power source wiring to terminal box by using buffer bushing for tensile force (PG connection or the like).
5. Narrow the opening by using a conduit to keep small animals out.
6. Use the terminal block for pump interlock (TB8) when interlocking the unit with the pump in the water circuit.
In this case, be sure to remove the short circuit wire on the terminal block for pump interlocking (TB8).
Run the cable to TB8 via the same route as the power supply line.

<Heat exchanger unit – compressor unit connection>

1. Connect the connectors on the compressor unit and the heat exchanger unit using the wires installed on the compressor unit (External heater adapter).
2. The top service panel can be removed by removing the three screws at the top, tilting the panel by pulling the top of it away from the unit body, and pulling it up.
3. The bottom service panel can be removed by first removing the top service panel, then removing the 3 screws at the top, tilting the panel by pulling the top of it away from the unit body, and pulling it up.
4. Wire the units as shown in the figure below.
Run the power supply line [0.75mm²] and control line [0.3mm²] separately and at least 5cm away from each other.
Keep them out of contact with the pipes.
Connect the heat exchanger unit and the compressor unit via 3 of the 4 connectors on each unit.

[Fig. 10.2.2] (P.6)

- Ⓐ Heat exchanger unit Ⓑ Compressor unit
- Ⓒ Cable clamp (power supply line) Ⓓ Cable clamp (control line)
- Ⓔ Control cable Ⓕ Power supply cable

- <A> Enlarged view of connector section
- Heat exchanger unit side
- <C> Compressor unit side
- <D> CN102B (For power supply line)
- <E> CN103B (For control line)
- <F> CN101B (For power supply line)
- <G> CN102A (For power supply line)
- <H> CN103A (For control line)
- <I> CN101A (For power supply line)

*1 CN104A is not used for the WR2 models.

5. The length of standard equipped wiring, not including the heat exchanger unit's and the compressor unit's internal wiring, is approximately 1.5m.
If longer wiring is required, use optional extension wire for water heat source (Available in 5 m and 10 m, not including the unit's internal wiring).
6. Clamp excess power supply line [0.75mm²] and control line [0.3mm²] separately with the cable clamps on the compressor unit's side panel.
Choose the appropriate size cable clamps for the amount of excess wiring.

[Fig. 10.2.3] (P.6)

- <A> Compressor unit
- Ⓐ Cable clamp for power supply cable
- Ⓑ Cable clamp for control cable

10.2. Control box and connecting position of wiring

<Wiring compressor unit, BC controller unit, and Indoor units>

1. The controller box for the BC controller/indoor unit wiring is on the compressor unit.
2. Connect the indoor unit transmission line to transmission terminal block (TB3), or connect the wiring between heat source units or the wiring with the central control system to the central control terminal block (TB7).
When using shielded wiring, connect shield ground of the indoor unit transmission line to the earth screw (Ⓒ) and connect shield ground of the line between heat source units and the central control system transmission line to the shield (S) terminal of the central control terminal block (TB7) shield (S) terminal. In addition, in the case of heat source units whose power supply connector CN41 has been replaced by CN40, the shield terminal (S) of terminal block (TB7) of the central control system should also be connected to the earth screw (Ⓒ).
Fix the wiring securely in place with the cable strap at the bottom of the terminal block so that the external force if not applied to the terminal block. External force applied to the terminal block may damage the block and short-circuit, ground fault, or fire may result.

[Fig. 10.2.1] (P.6)

- Ⓐ Power source Ⓑ Transmission line
- Ⓒ Earth screw



7. Heat exchanger unit – compressor unit connected cable.

Cable name	Cable 1	Cable 2	Cable 3	Cable 4 *1
Kind of control cable	8 core cable (unshielded) VCT *2	12 core cable (unshielded) VCT *2	12 core cable (unshielded) VCT *3	6 core cable (unshielded) VCT *3
Cable diameter	0.75 mm ²	0.75 mm ²	0.3 mm ²	0.3 mm ²
Maximum wiring length	10 m			
Remarks	Put the cable that connects the heat source units through a conduit tube. Connect both ends of the conduit tube to the unit's casing. Do not put cable 1 and cable 2 through the same conduit tube with cable 3 and cable 4.			

*1 : PQHY-P400, 500 type only

*2 : VCT cable is not be lighter than design 245 IEC57.

*3 : VCTF cable is not be lighter than design 245 IEC53.

10.3. Wiring transmission cables

① Types of control cables

1. Wiring transmission cables

- Types of transmission cables: Shielding wire CVVS or CPEVS or MVVS
- Cable diameter: More than 1.25 mm²
- Maximum wiring length: Within 200 m
- Maximum length of transmission lines for centralized control and indoor/outdoor transmission lines (Maximum length via indoor units): 500 m MAX

The maximum length of the wiring between power supply unit for transmission lines (on the transmission lines for centralized control) and each outdoor unit and system controller is 200 m.

Example of a group operation system with multiple heat source units (Shielding wires and address setting are necessary.)

<Examples of transmission cable wiring>

[Fig. 10.3.1] M-NET Remote Controller (P.7)

[Fig. 10.3.2] MA Remote Controller (P.7)

[Fig. 10.3.3] Transmission booster unit (P.7)

<A> Change the jumper connector from CN41 to CN40.

 SW2-1:ON

<C> Keep the jumper connector on CN41.

Ⓐ Group 1

Ⓑ Group 4

Ⓒ Group 5

Ⓓ Shielded wire

Ⓔ Sub remote controller

(): Address

<Wiring Method and Address Settings>

- Always use shielded wire when making connections between the heat source unit (OC) and the indoor unit (IC), as well for all OC-OC, and IC-IC wiring intervals.
- Use feed wiring to connect terminals M1 and M2 and the earth terminal on the transmission cable terminal block (TB3) of each heat source unit (OC) to terminals M1, M2 and terminal S on the transmission cable block of the indoor unit (IC).
- Connect terminals 1 (M1) and 2 (M2) on the transmission cable terminal block of the indoor unit (IC) that has the most recent address within the same group to the terminal block on the remote controller (RC).
- Connect together terminals M1, M2 and terminal S on the terminal block for central control (TB7) for the heat source unit (OC).
- On one heat source unit only, change the jumper connector on the control panel from CN41 to CN40.
- Connect the terminal S on the terminal block for central control (TB7) for the heat source unit (OC) for the unit into which the jumper connector was inserted into CN40 in Step above to the earth terminal  in the electrical component box.
- Set the address setting switch as follows.

* To set the outdoor unit address to 100, the outdoor address setting switch must be set to 50.

Unit	Range	Setting Method
IC (Main)	01 to 50	Use the most recent address within the same group of indoor units. With an R2 system with sub BC controllers, set the indoor unit address in the following order: ① Indoor units connected to the main BC controller ② Indoor units connected to BC sub controller 1 ③ Indoor units connected to BC sub controller 2 Set the indoor unit addresses so that all the addresses of ① are smaller than those of ②, and that all the addresses of ② are smaller than those of ③.
IC (Sub)	01 to 50	Use an address, other than that of the IC (Main) from among the units within the same group of indoor units. This must be in sequence with the IC (Main)
Heat source Unit	51 to 100	Use the most recent address of all the indoor units plus 50
BC controller (Main)	51 to 100	Heat source unit address plus 1. When the set indoor unit address duplicates the address of another indoor unit, set the new address to a vacant address within the setting range.
BC controller (Sub)	51 to 100	Lowest address within the indoor units connected to the BC controller (sub) plus 50
M-NET R/C (Main)	101 to 150	Set at an IC (Main) address within the same group plus 100
M-NET R/C (Sub)	151 to 200	Set at an IC (Main) address within the same group plus 150
MA R/C	–	Unnecessary address setting (Necessary main/sub setting)

- The group setting operations among the multiple indoor units is done by the remote controller (RC) after the electrical power has been turned on.

2. Remote control cables

• M-NET Remote Controller

Kind of remote control cable	Sheathed 2-core cable (unshielded)
Cable diameter	0.3 to 1.25 mm ² (0.75 to 1.25 mm ²)*
Remarks	When 10 m is exceeded, use cable with the same specifications as 1. Wiring transmission cables.

• MA Remote Controller

Kind of remote control cable	Sheathed 2-core cable (unshielded) CVV
Cable diameter	0.3 to 1.25 mm ² (0.75 to 1.25 mm ²)*
Remarks	Within 200 m

* Connected with simple remote controller.

② Wiring examples

- Controller name, symbol and allowable number of controllers.

Name	Symbol	Allowable number of controllers
Heat source unit controller	OC	
BC Controller (main)	BC	One controller for one OC
BC Controller (sub)	BS	Zero, one or two controllers for one OC
Transmission booster unit	RP	Zero or one unit for one OC (*1)
Indoor Unit Controller	IC	Two to twenty four controllers for one OC (*1)
Remote Controller	RC	Maximum of two per group

*1 A transmission booster (RP) may be required depending on the number of connected indoor unit controllers.

<Permissible Lengths>

① **M-NET Remote controller**

- Max length via outdoor units: $L_1 + L_2 + L_3 + L_4$ and $L_1 + L_2 + L_3 + L_5$ and $L_1 + L_2 + L_6 \leq 500$ m (1.25 mm² or more)
- Max transmission cable length: L_1 and $L_3 + L_4$ and $L_3 + L_5$ and L_6 and $L_2 + L_6 \leq 200$ m (1.25 mm² or more)
- Remote controller cable length: $l_1, l_2, l_3, l_4 \leq 10$ m (0.3 to 1.25 mm²)
If the length exceeds 10 m, use a 1.25 mm² shielded wire. The length of this section (L_8) should be included in the calculation of the maximum length and overall length.

② **MA Remote controller**

- Max length via outdoor unit (M-NET cable): $L_1 + L_2 + L_3 + L_4$ and $L_1 + L_2 + L_6 \leq 500$ m (1.25 mm² or more)
- Max transmission cable length (M-NET cable): L_1 and $L_3 + L_4$ and L_6 and $L_2 + L_6 \leq 200$ m (1.25 mm² or more)
- Remote controller cable length: m_1 and $m_1 + m_2 + m_3$ and $m_1 + m_2 + m_3 + m_4 \leq 200$ m (0.3 to 1.25 mm²)

③ **Transmission booster**

- Max transmission cable length (M-NET cable): ① $L_8 + L_1 + L_2 + L_3 + L_5 + L_6 \leq 200$ m (1.25 mm²)
② $L_8 + L_1 + L_2 + L_3 + L_5 + L_7 \leq 200$ m (1.25 mm²)
③ $L_8 + L_1 + L_2 + L_4 \leq 200$ m (1.25 mm²)
④ $L_6 + L_5 + L_3 + L_4, L_4 + L_3 + L_5 + L_7 \leq 200$ m (1.25 mm²)
- Remote controller cable length: $l_1, l_2 \leq 10$ m (0.3 to 1.25 mm²)
If the length exceeds 10 m, use 1.25 mm² shielded cable and calculate the length of that portion (L_4 and L_7) as within the total extended length and the longest remote length.

10.4. Wiring of main power supply and equipment capacity

Schematic Drawing of Wiring (Example)

[Fig. 10.4.1] (P.7)

- Ⓐ Switch (breakers for wiring and current leakage) Ⓑ Heat source unit (Compressor unit side) Ⓒ BC controller (main) Ⓓ BC controller (sub)
- Ⓔ Pull box Ⓔ Indoor unit Ⓔ Breakers for current leakage

Thickness of wire for main power supply, On/Off capacities and system impedance

		Minimum wire thickness (mm ²)			Switch (A)		Breaker for wiring (NFB)	Breaker for current leakage	Max. Permissible System Impedance
		Main cable	Branch	Ground	Capacity	Fuse			
Heat source	P400	10.0	10.0	10.0	63	63	60	60 A 100 mA 0.1sec. or less	0.32 Ω
	P500	10.0	10.0	10.0	63	63	60	60 A 100 mA 0.1sec. or less	0.23 Ω
Total operating current of the indoor unit	16 A or less	1.5	1.5	1.5	16	16	20	20 A 30 mA 0.1sec. or less	(apply to EN61000-3-3)
	25 A or less	2.5	2.5	2.5	25	25	30	30 A 30 mA 0.1sec. or less	(apply to EN61000-3-3)
	32 A or less	4.0	4.0	4.0	32	32	40	40 A 30 mA 0.1sec. or less	(apply to EN61000-3-3)

1. Use a separate power supply for the heat source unit and indoor unit.
2. Bear in mind ambient conditions (ambient temperature, direct sunlight, rain water, etc.) when proceeding with the wiring and connections.
3. The wire size is the minimum value for metal conduit wiring. The power cord size should be 1 rank thicker consideration of voltage drops. Make sure the power-supply voltage does not drop more than 10 %.
4. Specific wiring requirements should adhere to the wiring regulations of the region.
5. Power supply cords of parts of appliances for heat source use shall not be lighter than polychloroprene sheathed flexible cord (design 245 IEC57). For example, use wiring such as YZW.
6. A switch with at least 3 mm contact separation in each pole shall be provided by the Air conditioner installation.
7. This device is intended for the connection to a power supply system with a maximum permissible system impedance shown in the above table at the interface point (power service box) of the user's supply.
The user has to ensure that this device is connected only to a power supply system which fulfills the requirement above.
If necessary the user can the ask the public power supply company for the system impedance at the interface point.

⚠ Warning:

- Be sure to use specified wires to connect so that no external force is imparted to terminal connections. If connections are not fixed firmly, it may cause heating or fire.
- Be sure to use the appropriate type of overcurrent protection switch. Note that generated overcurrent may include some amount of direct current.

⚠ Caution:

- A breaker for current leakage must be attached to the power supply. If no earth leakage breaker is installed, it may cause an electric shock.
- Do not use anything other than breaker and fuse with correct capacity. Using fuse and wire or copper wire with too large capacity may cause a malfunction of unit or fire.

11. Test run

11.1. The following phenomena do not represent trouble (emergency)

Phenomenon	Display of remote controller	Cause
Indoor unit and BC controller generate sound at the cooling/heating change over sometime.	Normal display	This is not a trouble as it is just a selecting sound.
Indoor unit does not perform cooling (heating) operation.	"Cooling (heating)" flashes	When multiple indoor units (max. 3) are connected to the same branch of the BC controller, the heating (cooling) operation cannot be performed while another indoor unit is performing a cooling (heating) operation.
The auto vane runs freely.	Normal display	Because of the control operation of auto vane, it may change over to horizontal blow automatically from the downward blow in cooling in case the downward blow operation has been continued for 1 hour. At defrosting in heating, hot adjusting and thermostat OFF, it automatically changes over to horizontal blow.
Fan setting changes during heating.	Normal display	Ultra-low speed operation is commenced at thermostat OFF. Light air automatically changes over to set value by time or piping temperature at thermostat ON.
Fan stops during heating operation.	Defrost display	The fan is to stop during defrosting.
Fan does not stop while operation has been stopped.	No lighting	Fan is to run for 1 minute after stopping to exhaust residual heat (only in heating).
No setting of fan while start SW has been turned on.	Heat ready	Ultra low-speed operation for 5 minutes after SW ON or until piping temperature becomes 35°C, low speed operation for 2 minutes thereafter, and then set notch is commenced. (Hot adjust control)
Indoor unit remote controller shows "HO" or "PLEASE WAIT" indicator for about five minutes when turning ON universal power supply.	"HO" or "PLEASE WAIT" flashes	System is being driven. Operate remote controller again after "HO" or "PLEASE WAIT" disappear.
Drain pump does not stop while unit has been stopped.	Light out	After a stop of cooling operation, unit continues to operate drain pump for three minutes and then stops it.
Drain pump continues to operate while unit has been stopped.		Unit continues to operate drain pump if drainage is generated, even during a stop.

12. Information on rating plate

Model	PQRY-P400YGM-A	PQRY-P500YGM-A	PQY-P01YGM-A
Refrigerant (R410A) kg	-	-	12.0
Allowable pressure (Ps)	HP: 4.15 MPa, LP: 2.21 MPa		
Net weight kg	232	236	208
MANUFACTURER: MITSUBISHI ELECTRIC CORPORATION AIR-CONDITIONING & REFRIGERATION SYSTEMS WORKS 5-66, TEBIRA, 6-CHOME, WAKAYAMA CITY, JAPAN			

This product is designed and intended for use in the residential, commercial and light-industrial environment.

The product at hand is based on the following EU regulations:

- Low Voltage Directive 73/23/EEC
- Electromagnetic Compatibility Directive 89/336/EEC

Please be sure to put the contact address/telephone number on this manual before handing it to the customer.