

SERVICE PARTS LIST FOR MITSUBISHI ELECTRIC PACKAGED AIR-CONDITIONERS

**Series PQRV-P-YEM-A
PQHY-P-YEM-A**

For use with the R407C

Jan. 2004

INDEX

PQRV-P200YEM-A

PQRV-P250YEM-A

PQHY-P200YEM-A

PQHY-P250YEM-A

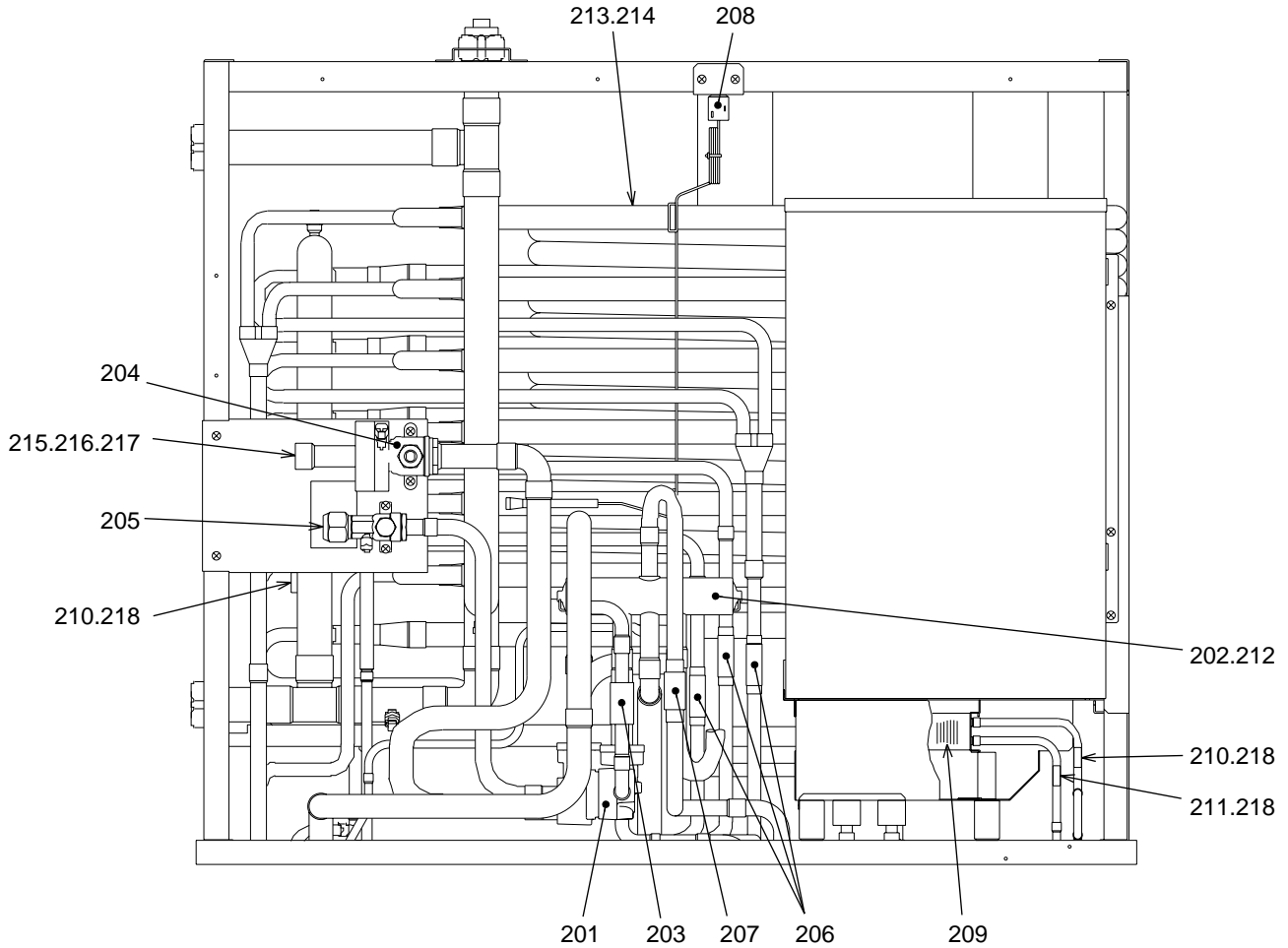

No.	Part No.	Part Name	Spec.	PQRY-P200YEM-A	PQRY-P250YEM-A					Dwg. No.	Price
201	R61 H50 418	Check valve block ass'y		1	1					W264806G02	
202	R61 E37 154	Four way valve		1	1					P633101X01	
203	R61 F14 418	Check valve		1	1					P639130X01	
204	R61 N12 410	Ball valve	P-25.4	1	1					P636269X01	
205	R61 Y02 410	Ball valve	3/4	1	1					P636224X01	
206	R61 Y02 454	Strainer		3	3					W858399G02	
207	R61 800 454	Strainer		1	1					W834000H02	
208	R61 625 200	Thermostat	<26W>	1	1					P425296X01	
209	R61 K89 480	Heat exchanger		1	1					W639813G01	
210	R61 670 202	Thermistor	(NTH3A14)<TH6 INV>	2	2					P425496X01	
211	R61 F14 200	Thermistor	<TH2>	1	1					P425565X01	
212	R61 Y03 242	Four way valve coil	<21S4>	1	1					P633078X01	
213	R61 Y80 480	Heat exchanger ass'y		1						W267338G07	
214	R61 Y81 480	Heat exchanger ass'y			1					W267334G09	
215	R61 Y05 494	Pipe ass'y		1						W656083G03	
216	R61 Y06 494	Pipe ass'y			1					W656083G04	
217	R61 F14 514	Packing		1	1					P321009X01	
218	R13 658 276	TH spring		3	3					C38D815H01	

No. : For use with R407C

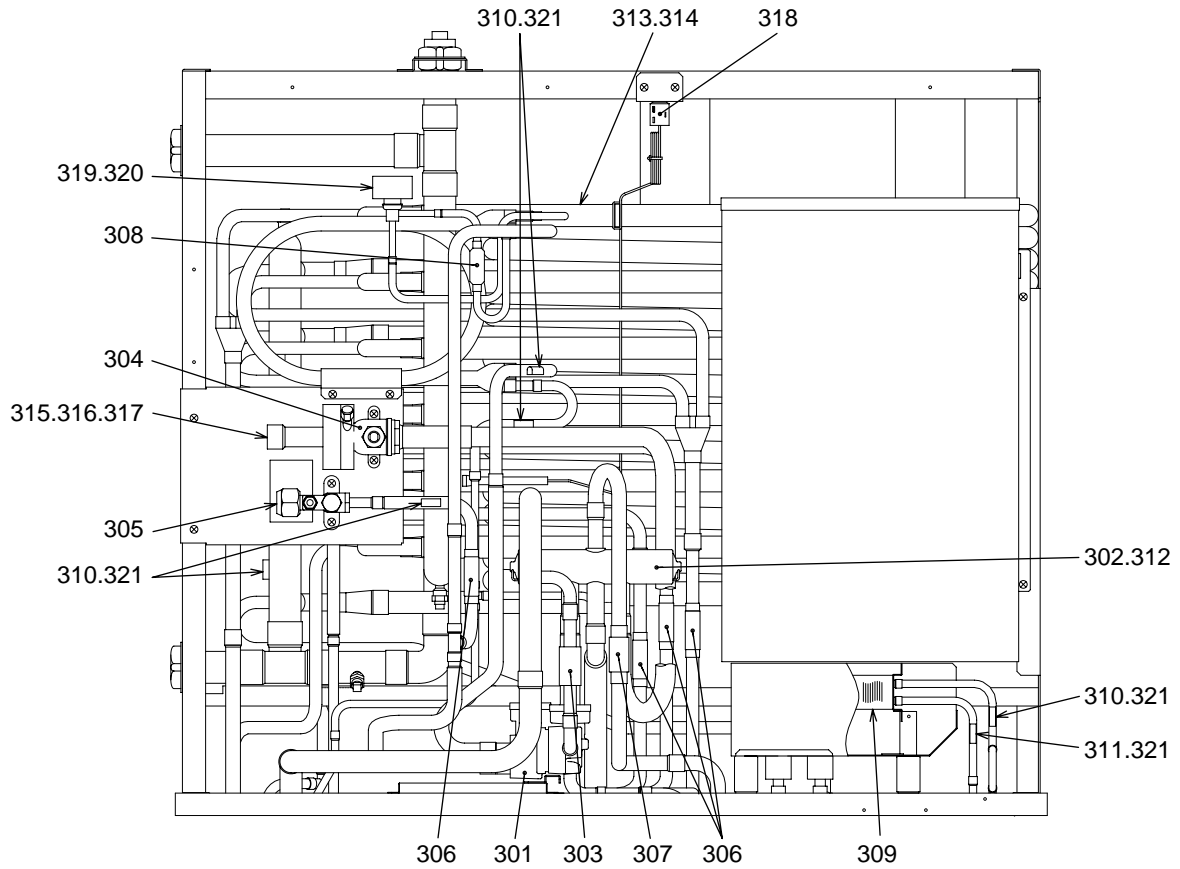

No.	Part No.	Part Name	Spec.	PQHY-P200YEM-A	PQHY-P250YEM-A					Dwg. No.	Price
301	R61 M38 418	Check valve block ass'y		1	1					W271326G01	
302	R61 E37 154	Four way valve		1	1					P633101X01	
303	R61 F14 418	Check valve		1	1					P639130X01	
304	R61 N12 410	Ball valve	P-25.4	1	1					P636269X01	
305	R61 F14 410	Ball valve	1/2	1	1					P636220X02	
306	R61 Y02 454	Strainer		4	4					W858399G02	
307	R61 800 454	Strainer		1	1					W834000H02	
308	R61 A42 454	Strainer		1	1					W882823G01	
309	R61 K89 480	Heat exchanger		1	1					W639813G01	
310	R61 670 202	Thermistor	(NTH3A14)<TH5-8 INV>	5	5					P425496X01	
311	R61 F14 200	Thermistor	<TH2>	1	1					P425565X01	
312	R61 Y03 242	Four way valve coil	<21S4>	1	1					P633078X01	
313	R61 Y80 480	Heat exchanger ass'y		1						W267338G07	
314	R61 Y81 480	Heat exchanger ass'y			1					W267334G09	
315	R61 Y05 494	Pipe ass'y		1						W656083G03	
316	R61 Y06 494	Pipe ass'y			1					W656083G04	
317	R61 F14 514	Packing		1	1					P321009X01	
318	R61 625 200	Thermostat	<26W>	1	1					P425296X01	
319	R61 G48 401	Linear expansion valve	DKV-18D124	1	1					P632342X01	
320	R61 M38 463	Wiring processing	<LEV1>	1	1					W892020G02	
321	R13 658 276	TH spring		6	6					C38D815H01	

[No.] : For use with R407C

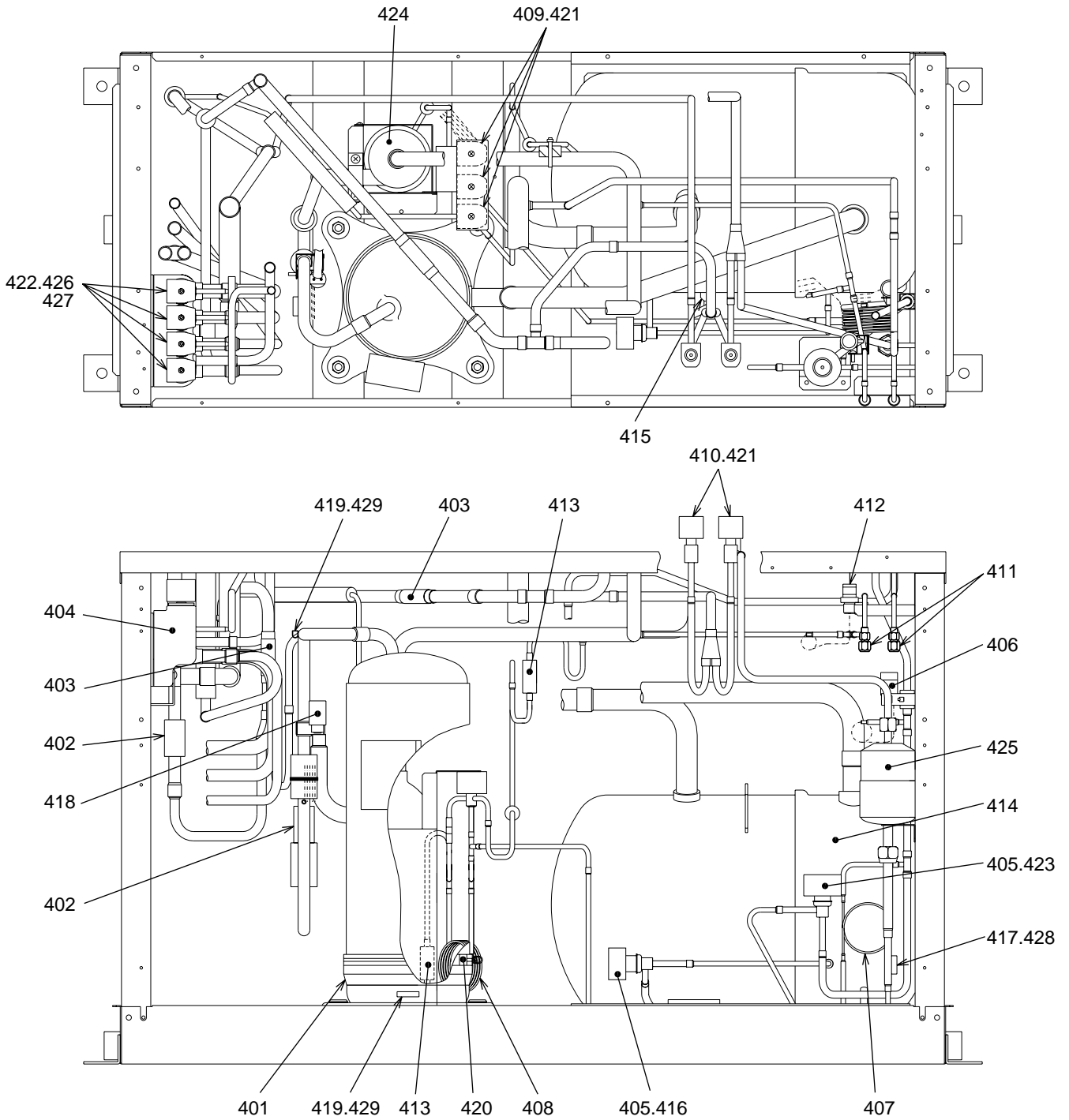

CONTROL BOX PARTS

