

# CITY MULTI™ HEAT SOURCE UNITS

# WY SERIES

WY SERIES

- 1. SPECIFICATIONS
- 2. CAPACITY TABLES
  - 2.1 Correction by temperature
  - 2.2 Correction by total indoor
  - 2.3 Correction by refrigerant piping length
  - 2.4 Temp. range of running
- 3. SOUND LEVELS
- 4. EXTERNAL DIMENSIONS
- 5. ELECTRICAL WIRING DIAGRAMS
- 6. REFRIGERANT CIRCUIT DIAGRAMS AND THERMAL SENSORS
- 7. SYSTEM DESIGN GUIDE

- WY-2
- WY-5
- WY-5
- WY-9
- WY-10
- WY-12
- WY-13
- WY-14
- WY-16
- WY-17
- WY-19

- Y
- R2
- WY**
- WR2
- S
- OP

Heat pump: PQHY-P-Y(S)GM-A

	200	250	300	350	400	450	500	550	600	650	700	750	800	850	900	950	1000	1050	1100	1150	1200	1250
	8HP	10HP	12HP	14HP	16HP	18HP	20HP	22HP	24HP	26HP	28HP	30HP	32HP	34HP	36HP	38HP	40HP	42HP	44HP	46HP	48HP	50HP
WY Heat pump	●	●			●		●															

# 1. SPECIFICATIONS

R410A Data G2

Model			PQHY-P200YGM-A	PQHY-P250YGM-A	
Power source			3-phase 4-wire 380-400-415V 50 / 60Hz		
Cooling capacity (Nominal)	*1	kW	22.4	28.0	
	*1	kcal / h	19,300	24,100	
	*1	Btu / h	76,400	95,500	
	Power input		kW	4.79	5.95
	Current input		A	8.0 - 7.6 - 7.4	10.0 - 9.5 - 9.1
COP (kW / kW)			4.68	4.71	
Temp. range of cooling	Indoor		15 ~ 24°CWB (59 ~ 75°FWB)		
	Circulating water		10 ~ 45°C (50 ~ 113°F)		
Heating capacity (Nominal)	*2	kW	25.0	31.5	
	*2	kcal / h	21,500	27,100	
	*2	Btu / h	85,300	107,500	
	Power input		kW	4.69	5.8
	Current input		A	7.9 - 7.5 - 7.2	9.7 - 9.3 - 8.9
COP (kW / kW)			5.33	5.43	
Temp. range of heating	Indoor		15 ~ 27°CDB (59 ~ 81°FDB)		
	Circulating water		10 ~ 45°C (50 ~ 113°F)		
Indoor unit connectable	Total capacity		50 ~ 130% of Heat source unit capacity		
	Model / Quantity		P20 ~ P250 / 1 ~ 13	P20 ~ P250 / 1 ~ 16	
Noise level (measured in anechoic room)	dB <A>		46 / 46	47 / 47	
Diameter of refrigerant pipe	Liquid (High press.)	mm (in.)	ø9.52 (ø3/8") Flare	ø9.52 (ø3/8") Flare (ø12.7 (ø1/2") Flare, total length >= 90m)	
	Gas (Low press.)	mm (in.)	ø19.05 (ø3/4") Brazed	ø22.2 (ø7/8") Brazed	

External finish			Acrylic painted steel plate	
External dimension H x W x D	mm		1,800 x 990 x 550	1,800 x 990 x 550
	in.		70-7/8" x 39" x 21-5/8"	70-7/8" x 39" x 21-5/8"
Net weight	kg (lb)		272 (600)	275 (607)
Heat exchanger			Pipe-in-pipe coil	Pipe-in-pipe coil
	Water volume in coil	l	9.5	10.5
	Water pressure Max.	MPa	1.0	1.0
Compressor	Type		Inverter scroll hermetic comp.	Inverter scroll hermetic comp.
	Manufacturer		AC&R Works, MITSUBISHI ELECTRIC CORPORATION	
	Starting method		Inverter	
	Motor output	kW	5	6
	Case heater	kW	0.045 x 1 (240V)	0.045 x 1 (240V)
	Lubricant		MEL32	MEL32
Circulating water	Water flow rate	m <sup>3</sup> / h	4.56	5.76
		L / min	76	96
		cfm	2.7	3.4
	Pressure drop	kPa	16.5	19.5
	Operating volume range	m <sup>3</sup> / h	3.9 - 6.0	4.5 - 7.2
HIC circuit (HIC: Heat Inter-Changer)			Pipe-in-pipe structure	
Protection	High pressure protection		High pressure sensor, High pressure switch 4.15 MPa (601 psi)	
	Inverter circuit		Over-current protection, Thermal protection	
	Compressor		Over-current protection, Over-heat protection	
Refrigerant	Type x Original charge		R410A x 7.0 kg (16 lb)	R410A x 9.5 kg (21 lb)
	Control		LEV and HIC circuit	
Drawing	External		OU-W663145	
	Wiring		OU-W274643	
	Refrigerant circle		RC_WYNA1-1133-13	
Standard attachment	Document		Installation Manual	
	Accessory		Details refer to External Drw. YGM-CM04EU4-C_P18(W663145)	
Optional parts			Joint : CMY-Y102S-G Header : CMY-Y104/108/1010-G	Joint : CMY-Y102S/L-G Header : CMY-Y104/108/1010-G
Remark			<p>a. The ambient temperature of the Heat Source Unit PQHY-P-YGM-A needs to be kept below 40°CDB.</p> <p>b. The ambient relative humidity of the Heat Source Unit PQHY-P-YGM-A needs to be kept below 80%.</p> <p>c. The Heat Source Unit PQHY-P-YGM-A should not be installed at outdoor.</p> <p>d. Details on foundation work, duct work, insulation work, electrical wiring, power source switch, and other items shall be referred to the Installation Manual.</p>	

**Note :**      \*1 Nominal cooling conditions      \*2 Nominal heating conditions

Indoor :	27°CDB/19°CWB (81°FDB/66°FWB)	20°CDB (68°FDB)
Water temperature:	30°C (86°F)	20°C (68°F)
Pipe length :	7.5 m (24-9/16 ft)	7.5 m (24-9/16 ft)
Level difference :	0 m (0 ft)	0 m (0 ft)

Unit converter

kcal/h	= kW x 860
Btu/h	= kW x 3,412
cfm	= m <sup>3</sup> /min x 35.31
lb	= kg / 0.4536

\*Above specification data is subject to rounding variation.

\* Nominal conditions \*1, \*2 are subject to JIS B8615-1.

\* Due to continuing improvement, above specifications may be subject to change without notice.

Ref. : Spec\_wy\_p200\_250ygm

# 1. SPECIFICATIONS

R410A Data G2

Model (Set name)		PQHY-P400YSGM-A	
Power source		3-phase 4-wire 380-400-415V 50 / 60Hz	
Cooling capacity (Nominal)	*:1	kW	45.0
	*:1	kcal / h	38,700
	*:1	Btu / h	153,500
	Power input	kW	11.35
	Current input	A	19.1 - 18.2 - 17.5
COP (kW / kW)		3.96	
Temp. range of cooling	Indoor	15 ~ 24°CWB (59 ~ 75°FWB)	
	Circulating water	10 ~ 45°C (50 ~ 113°F)	
Heating capacity (Nominal)	*:2	kW	50.0
	*:2	kcal / h	43,000
	*:2	Btu / h	170,600
	Power input	kW	11.01
	Current input	A	18.5 - 17.6 - 17.0
COP (kW / kW)		4.54	
Temp. range of heating	Indoor	15 ~ 27°CDB (59 ~ 81°FDB)	
	Circulating water	10 ~ 45°C (50 ~ 113°F)	
Indoor unit connectable	Total capacity	50 ~ 130% of Heat source unit capacity	
	Model / Quantity	P20 ~ P250 / 1 ~ 22	
Noise level (measured in anechoic room)	dB <A>		50 / 50
Diameter of refrigerant pipe	Liquid (High press.)	mm (in.)	ø12.7 (ø1/2") Flare
	Gas (Low press.)	mm (in.)	ø28.58 (ø1-1/8") Braze

The Set model is a combination of Compressor unit and Sub unit as follows.

Model (Compressor unit and Sub unit)		PQY-P01YGM-A (Compressor unit)		PQHY-P400YGM-A (Sub unit)	
External finish		Acrylic painted steel plate			
External dimension H x W x D	mm	1,800 x 990 x 550		1,800 x 990 x 550	
	in.	70-7/8" x 39" x 21-5/8"		70-7/8" x 39" x 21-5/8"	
Net weight	kg (lb)	208 (459)		244 (538)	
Heat exchanger			-		
	Water volume in coil	l	-		Pipe-in-pipe coil
	Water pressure Max.	MPa	-		17.5
Compressor	Type		Inverter scroll hermetic comp.		
	Manufacturer	kW	AC&R Works, MITSUBISHI ELECTRIC CORPORATION		
	Starting method	kW	Inverter		
	Motor output		9.7		
	Case heater		0.045 x 1 (240V)		
	Lubricant		MEL32		
Circulating water	Water flow rate	m <sup>3</sup> / h	9.12		
		L / min	152		
		cfm	5.4		
	Pressure drop	kPa	16.5		
Operating volume range	m <sup>3</sup> / h	7.8 - 12.0			
HIC circuit (HIC: Heat Inter-Changer)		-		Pipe-in-pipe structure	
Protection	High pressure protection		High pressure sensor, High pressure switch 4.15 MPa (601 psi)		
	Inverter circuit		Over-current protection, Thermal protection		
	Compressor		Over-current protection, Over-heat protection		
Refrigerant	Type x Original charge		R410A x 7.0 kg (16 lb)	R410A x 9.5 kg (21 lb)	
	Control		LEV and HIC circuit		
Refrigerant piping diameter (between comp. & sub)		ø9.52 (ø3/8") Flare / ø19.05 (ø3/4") Flare / ø28.58 (ø1-1/8") Braze			
Drawing	External		OU-W663147		
	Wiring		OU-W274643		
	Refrigerant circle		RC_WYNA3-1133-14		
Standard attachment	Document		Installation Manual		
	Accessory		Details refer to External Drw. YSGM-CM04EU4-C_P19(W663147)		
Optional parts		Joint : CMY-Y102S/L-G Header : CMY-Y104/108/1010-G			
Remark		<p>a. The ambient temperature of the Heat Source Unit PQHY-P-YSGM-A needs to be kept below 40°CDB.</p> <p>b. The ambient relative humidity of the Heat Source Unit PQHY-P-YSGM-A needs to be kept below 80%.</p> <p>c. The Heat Source Unit PQHY-P-YSGM-A should not be installed at outdoor.</p> <p>d. Details on foundation work, duct work, insulation work, electrical wiring, power source switch, and other items shall be referred to the Installation Manual.</p>			

Note :	*:1 Nominal cooling conditions	*:2 Nominal heating conditions	Unit converter
	Indoor : 27°CDB/19°CWB (81°FDB/66°FWB)	20°CDB (68°FDB)	kcal/h = kW x 860
	Water temperature: 30°C (86°F)	20°C (68°F)	Btu/h = kW x 3,412
	Pipe length : 7.5 m (24-9/16 ft)	7.5 m (24-9/16 ft)	cfm = m <sup>3</sup> /min x 35.31
	Level difference : 0 m (0 ft)	0 m (0 ft)	lb = kg / 0.4536
* Nominal conditions *:1, *:2 are subject to JIS B8615-1.			*Above specification data is subject to rounding variation.
* Due to continuing improvement, above specifications may be subject to change without notice.			

Ref. : Spec\_wy\_p400ysgm

# 1. SPECIFICATIONS

R410A Data G2

Model (Set name)			PQHY-P500YSGM-A		
Power source			3-phase 4-wire 380-400-415V 50 / 60Hz		
Cooling capacity (Nominal)	*1	kW	56.0		
	*1	kcal / h	48,200		
	*1	Btu / h	191,100		
	Power input		kW	15.06	
	Current input		A	25.4 - 24.2 - 23.3	
COP (kW / kW)			3.72		
Temp. range of cooling	Indoor		15 ~ 24°CWB (59 ~ 75°FWB)		
	Circulating water		10 ~ 45°C (50 ~ 113°F)		
Heating capacity (Nominal )	*2	kW	63.0		
	*2	kcal / h	54,200		
	*2	Btu / h	215,000		
	Power input		kW	13.60	
	Current input		A	22.9 - 21.8 - 21.0	
COP (kW / kW)			4.63		
Temp. range of heating	Indoor		15 ~ 27°CDB (59 ~ 81°FDB)		
	Circulating water		10 ~ 45°C (50 ~ 113°F)		
Indoor unit connectable	Total capacity		50 ~ 130% of Heat source unit capacity		
	Model / Quantity		P20 ~ P250 / 1 ~ 24		
Noise level (measured in anechoic room)		dB <A>	53 / 53		
Diameter of refrigerant pipe	Liquid (High press.)		mm (in.)		
	Gas (Low press.)		mm (in.)		
			ø15.88 (ø5/8") Flare ø28.58 (ø1-1/8") Brazed		

The Set model is a combination of Compressor unit and Sub unit as follows.

Model (Compressor unit and Sub unit)			PQY-P01YGM-A (Compressor unit)		PQHY-P500YGM-A (Sub unit)	
External finish			Acrylic painted steel plate			
External dimension H x W x D	mm		1,800 x 990 x 550		1,800 x 990 x 550	
	in.		70-7/8" x 39" x 21-5/8"		70-7/8" x 39" x 21-5/8"	
Net weight		kg (lb)	208 (459)		248 (547)	
Heat exchanger			-		Pipe-in-pipe coil	
	Water volume in coil		l		-	
	Water pressure Max.		MPa		-	
Compressor	Type		Inverter scroll hermetic comp.		-	
	Manufacturer		kW		AC&R Works, MITSUBISHI ELECTRIC CORPORATION	
	Starting method		kW		Inverter	
	Motor output				9.7	
	Case heater				0.045 x 1 (240V)	
	Lubricant				MEL32	
Circulating water	Water flow rate	m <sup>3</sup> / h	11.52			
		L / min	192			
		cfm	6.8			
	Pressure drop	kPa	19.5			
Operating volume range		m <sup>3</sup> / h	9.0 - 14.4			
HIC circuit (HIC: Heat Inter-Changer)			-		Pipe-in-pipe structure	
Protection	High pressure protection		High pressure sensor, High pressure switch 4.15 MPa (601 psi)			
	Inverter circuit		Over-current protection, Thermal protection			
	Compressor		Over-current protection, Over-heat protection			
Refrigerant	Type x Original charge		R410A x 7.0 kg (16 lb)		R410A x 9.5 kg (21 lb)	
	Control		LEV and HIC circuit			
Refrigerant piping diameter (between comp. & sub)			ø9.52 (ø3/8") Flare / ø19.05 (ø3/4") Flare / ø28.58 (ø1-1/8") Brazed			
Drawing	External		OU-W663147			
	Wiring		OU-W274643			
	Refrigerant circle		RC_WYNA3-1133-14			
Standard attachment	Document		Installation Manual			
	Accessory		Details refer to External Drw. YSGM-CM04EU4-C_P19(W663147)			
Optional parts			Joint : CMY-Y102S/L-G Header : CMY-Y104/108/1010-G			
Remark			<p>a. The ambient temperature of the Heat Source Unit PQHY-P-YSGM-A needs to be kept below 40°CDB.</p> <p>b. The ambient relative humidity of the Heat Source Unit PQHY-P-YSGM-A needs to be kept below 80%.</p> <p>c. The Heat Source Unit PQHY-P-YSGM-A should not be installed at outdoor.</p> <p>d. Details on foundation work, duct work, insulation work, electrical wiring, power source switch, and other items shall be referred to the Installation Manual.</p>			

Note :			Unit converter	
*1 Nominal cooling conditions		*2 Nominal heating conditions		
Indoor :	27°CDB/19°CWB (81°FDB/66°FWB)	20°CDB (68°FDB)	kcal/h = kW x 860	
Water temperature:	30°C (86°F)	20°C (68°F)	Btu/h = kW x 3,412	
Pipe length :	7.5 m (24-9/16 ft)	7.5 m (24-9/16 ft)	cfm = m <sup>3</sup> /min x 35.31	
Level difference :	0 m (0 ft)	0 m (0 ft)	lb = kg / 0.4536	
* Nominal conditions *1, *2 are subject to JIS B8615-1.				* Above specification data is subject to rounding variation.
* Due to continuing improvement, above specifications may be subject to change without notice.				

Ref. : Spec\_wy\_p500ysgm

# 2. CAPACITY TABLES

## 2-1. Correction by temperature

CITY MULTI™ could have varied capacity at different designing temperature. Using the nominal cooling/heating capacity value and the ratio below, the capacity can be observed at various temperature.

PQHY-		P200YGM
Nominal Cooling Capacity	kW	22.4
	kcal/h	19,300
	Btu/h	76,400
Input	kW	4.79

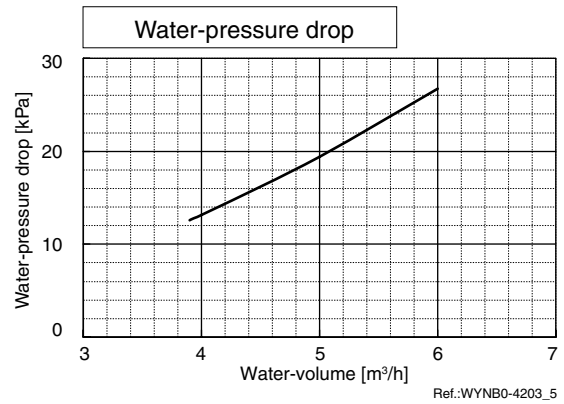
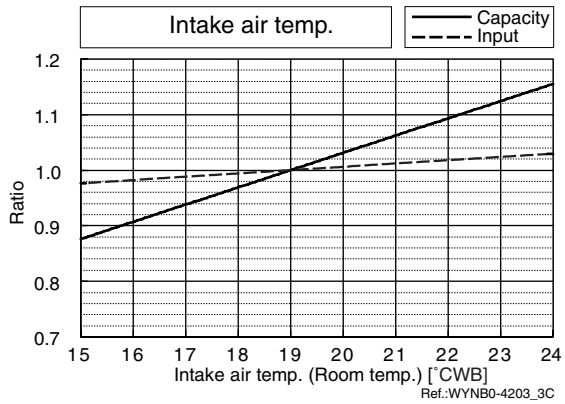
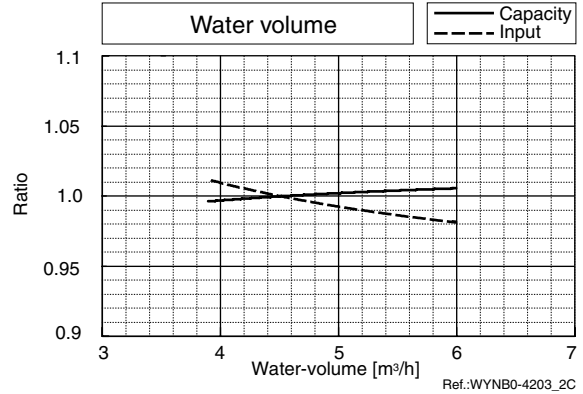
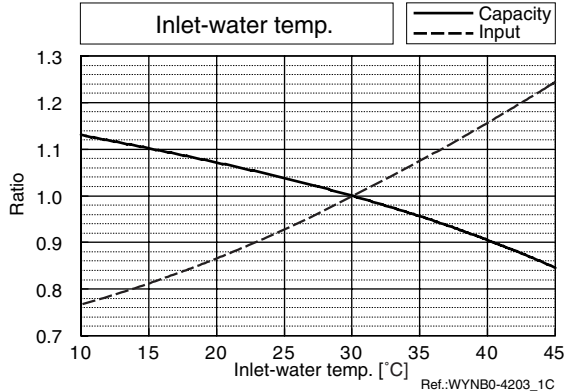

PQHY-		P200YGM
Nominal Heating Capacity	kW	25.0
	kcal/h	21,500
	Btu/h	85,300
Input	kW	4.69

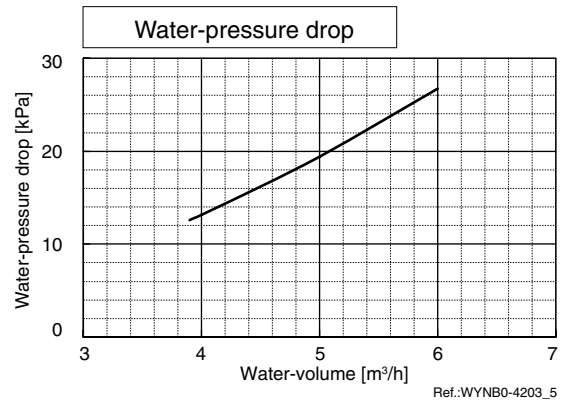
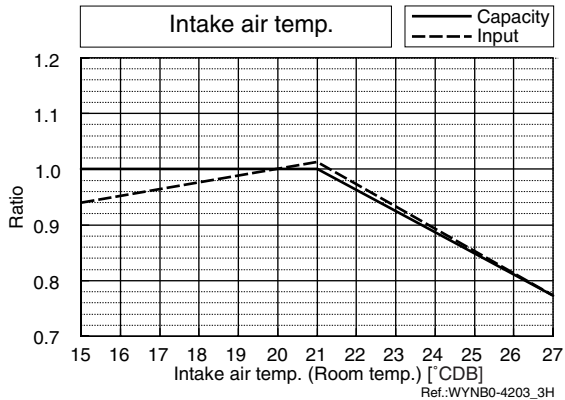
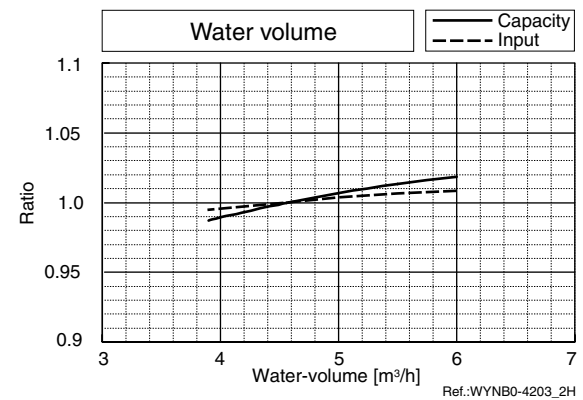
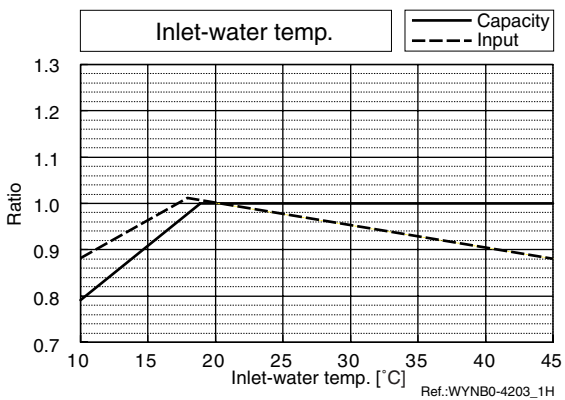

2-1. Correction by temperature

CITY MULTI™ could have varied capacity at different designing temperature. Using the nominal cooling/heating capacity value and the ratio below, the capacity can be observed at various temperature.

PQHY-		P250YGM
Nominal Cooling Capacity	kW	28.0
	kcal/h	24,100
	Btu/h	95,500
Input	kW	5.95

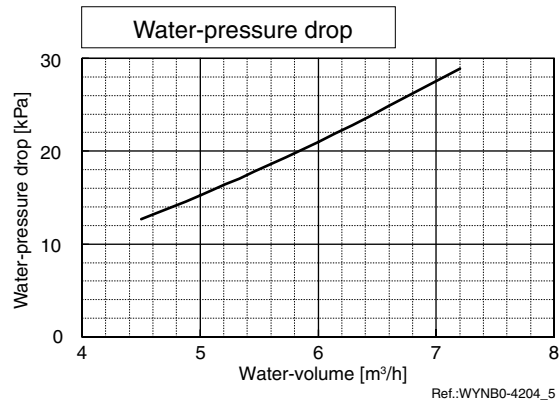
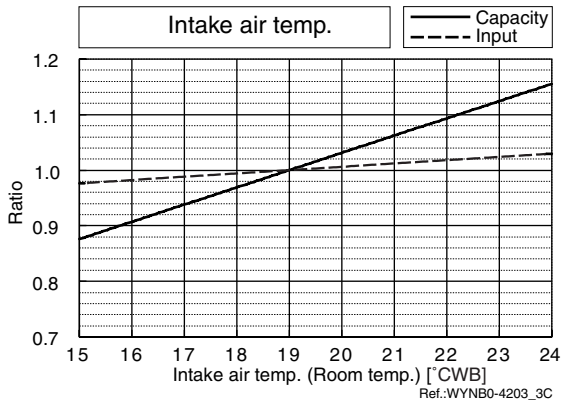
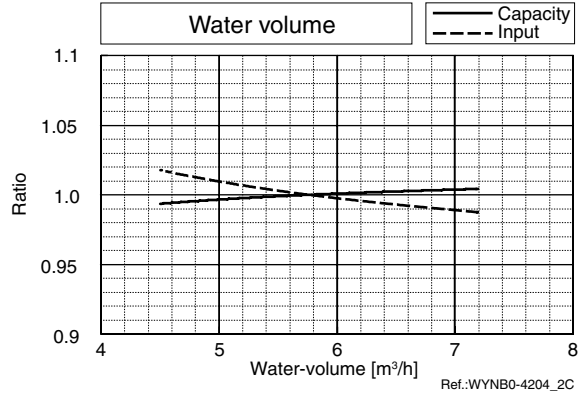
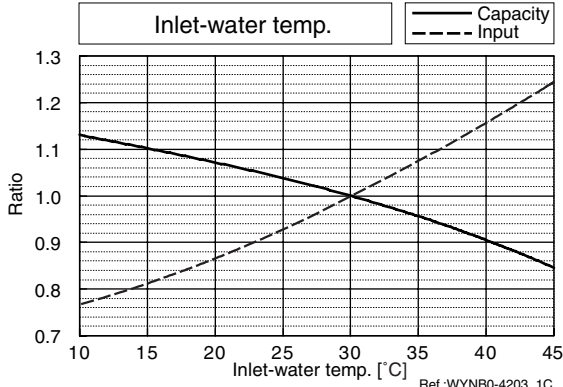

PQHY-		P250YGM
Nominal Heating Capacity	kW	31.5
	kcal/h	27,100
	Btu/h	107,500
Input	kW	5.8

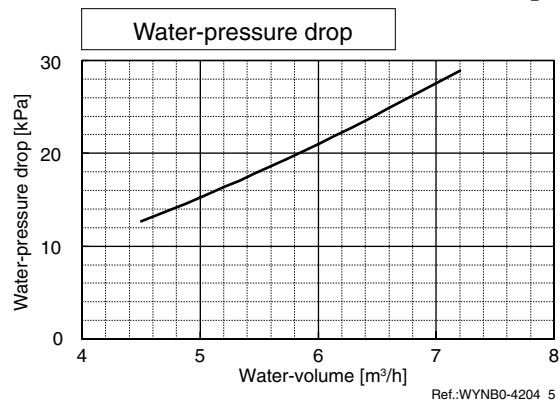
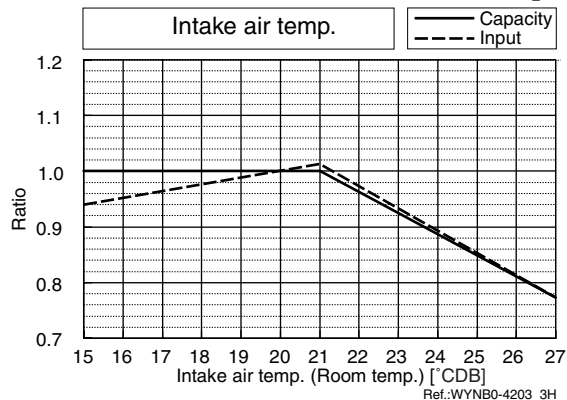
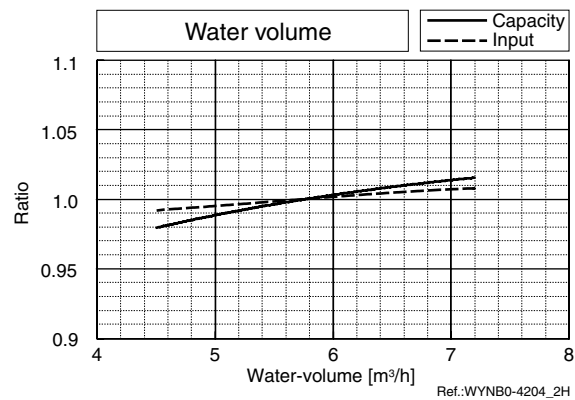
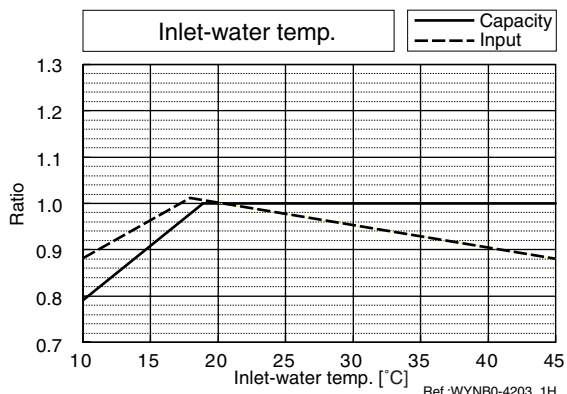

# 2. CAPACITY TABLES

## 2-1. Correction by temperature

CITY MULTI™ could have varied capacity at different designing temperature. Using the nominal cooling/heating capacity value and the ratio below, the capacity can be observed at various temperature.

PQHY-		P400YSGM
Nominal Cooling Capacity	kW	45.0
	kcal/h	38,700
	Btu/h	153,500
Input	kW	11.35

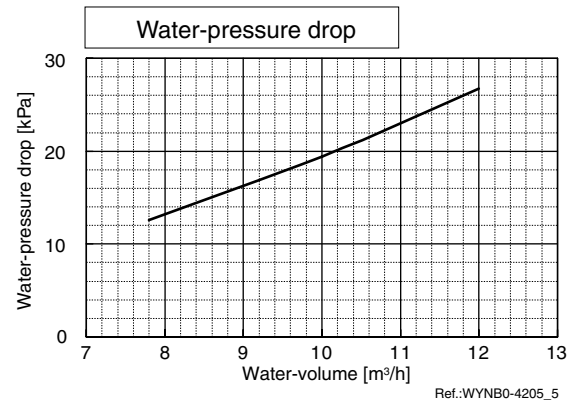
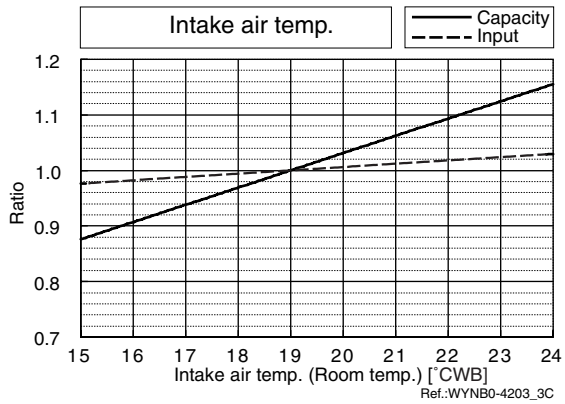
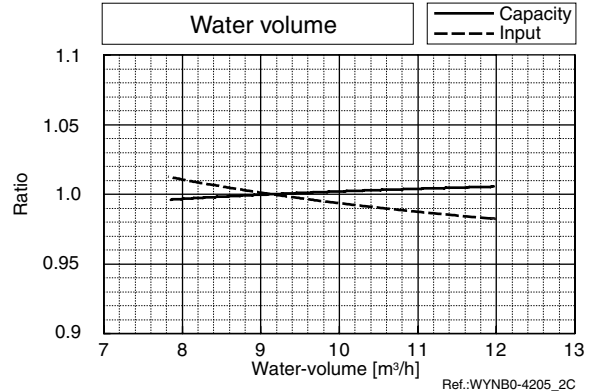
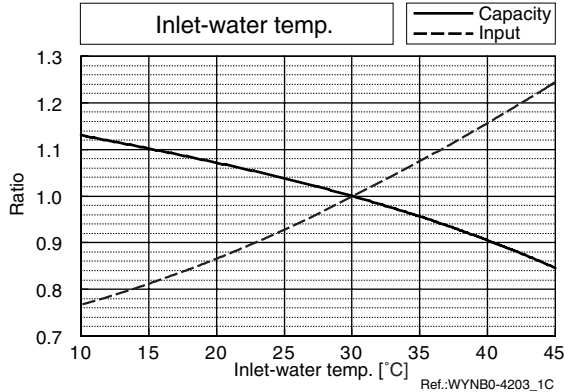

PQHY-		P400YSGM
Nominal Heating Capacity	kW	50.0
	kcal/h	43,000
	Btu/h	170,600
Input	kW	11.01

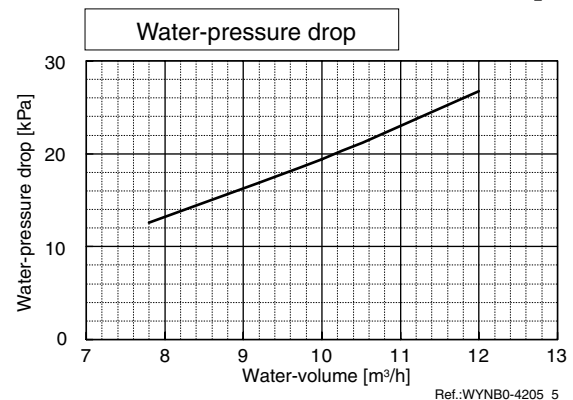
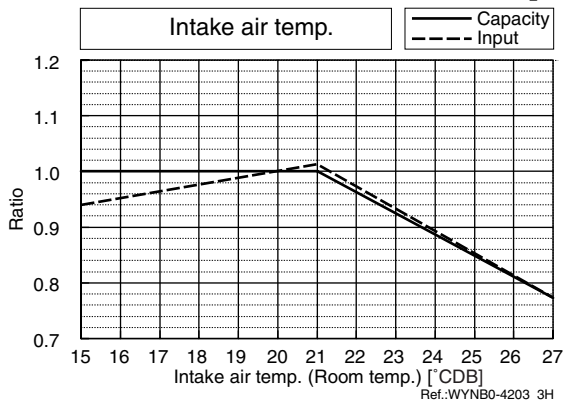
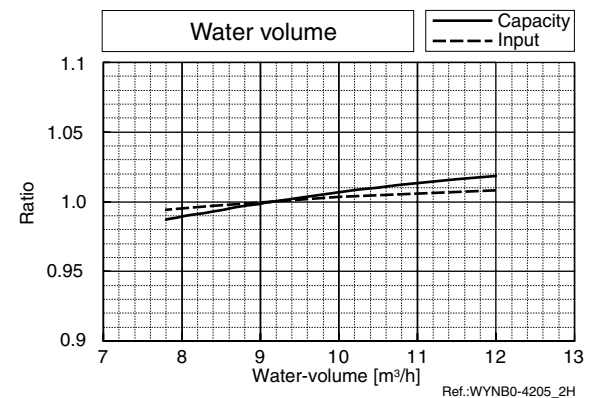
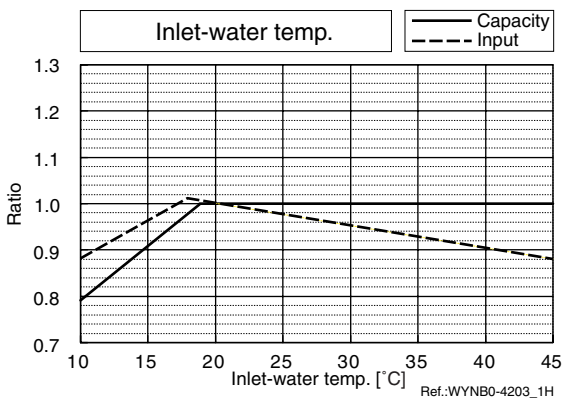

## 2-1. Correction by temperature

CITY MULTI™ could have varied capacity at different designing temperature. Using the nominal cooling/heating capacity value and the ratio below, the capacity can be observed at various temperature.

PQHY-		P500YSGM
Nominal Cooling Capacity	kW	56.0
	kcal/h	48,200
	Btu/h	191,100
Input	kW	15.06

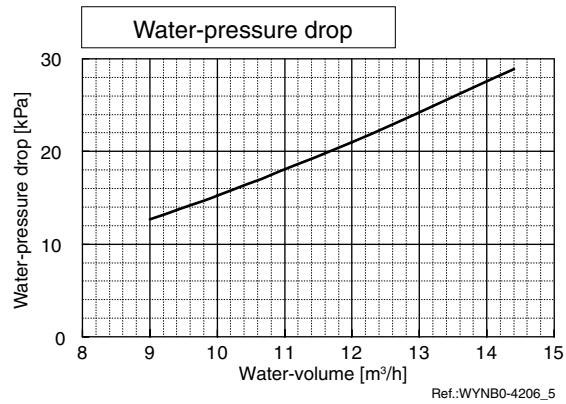
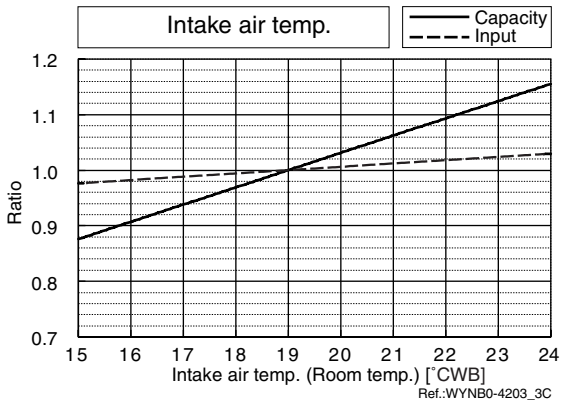
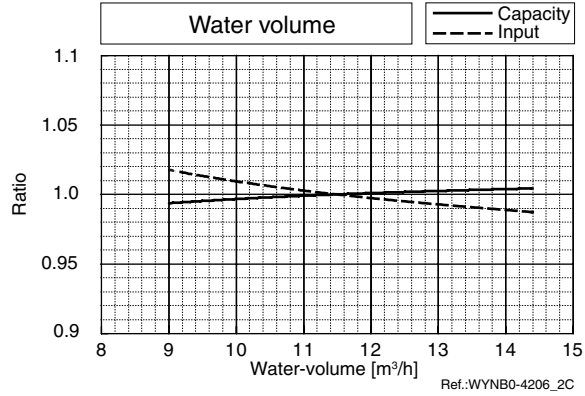
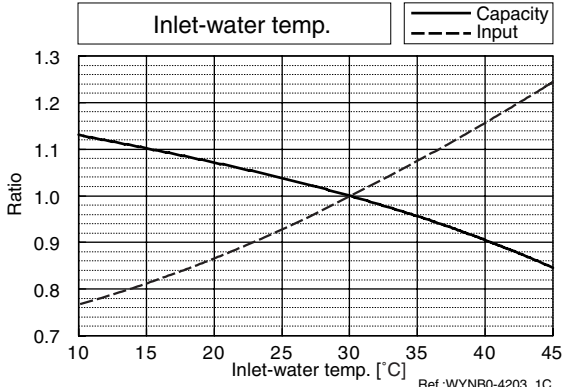

PQHY-		P500YSGM
Nominal Heating Capacity	kW	63.0
	kcal/h	54,200
	Btu/h	215,000
Input	kW	13.60

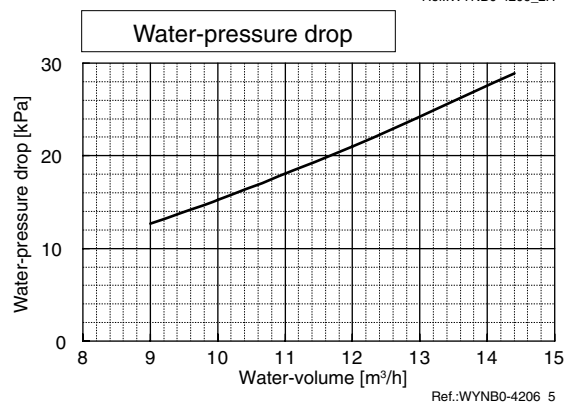
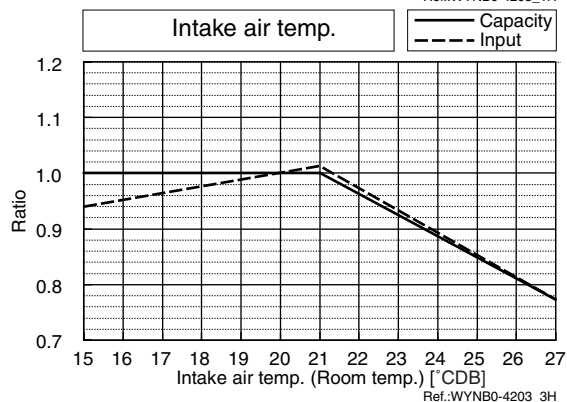
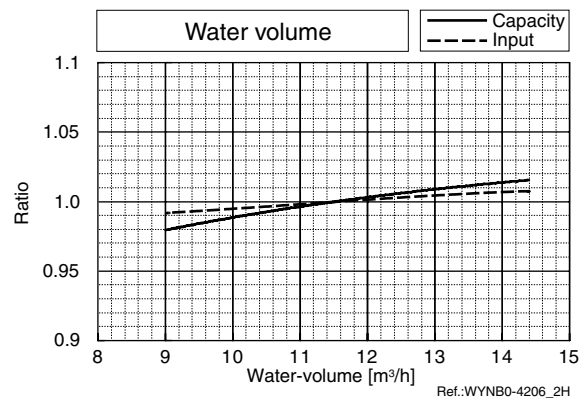
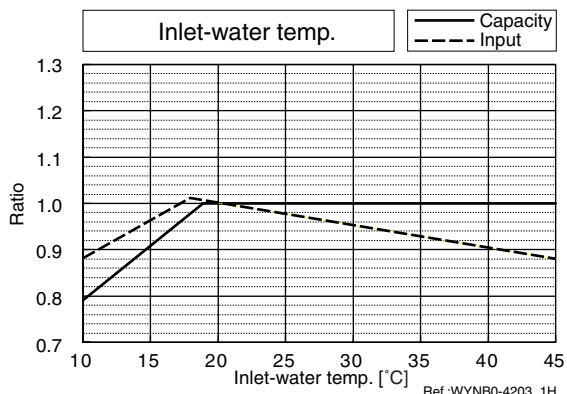



## 2. CAPACITY TABLES

### 2-2. Correction by total indoor

CITY MULTI™ system has different capacity and input at different total capacity of indoor unit connected. Using following tables, the maximum capacity can be observed so as to ensure the system having enough capacity.

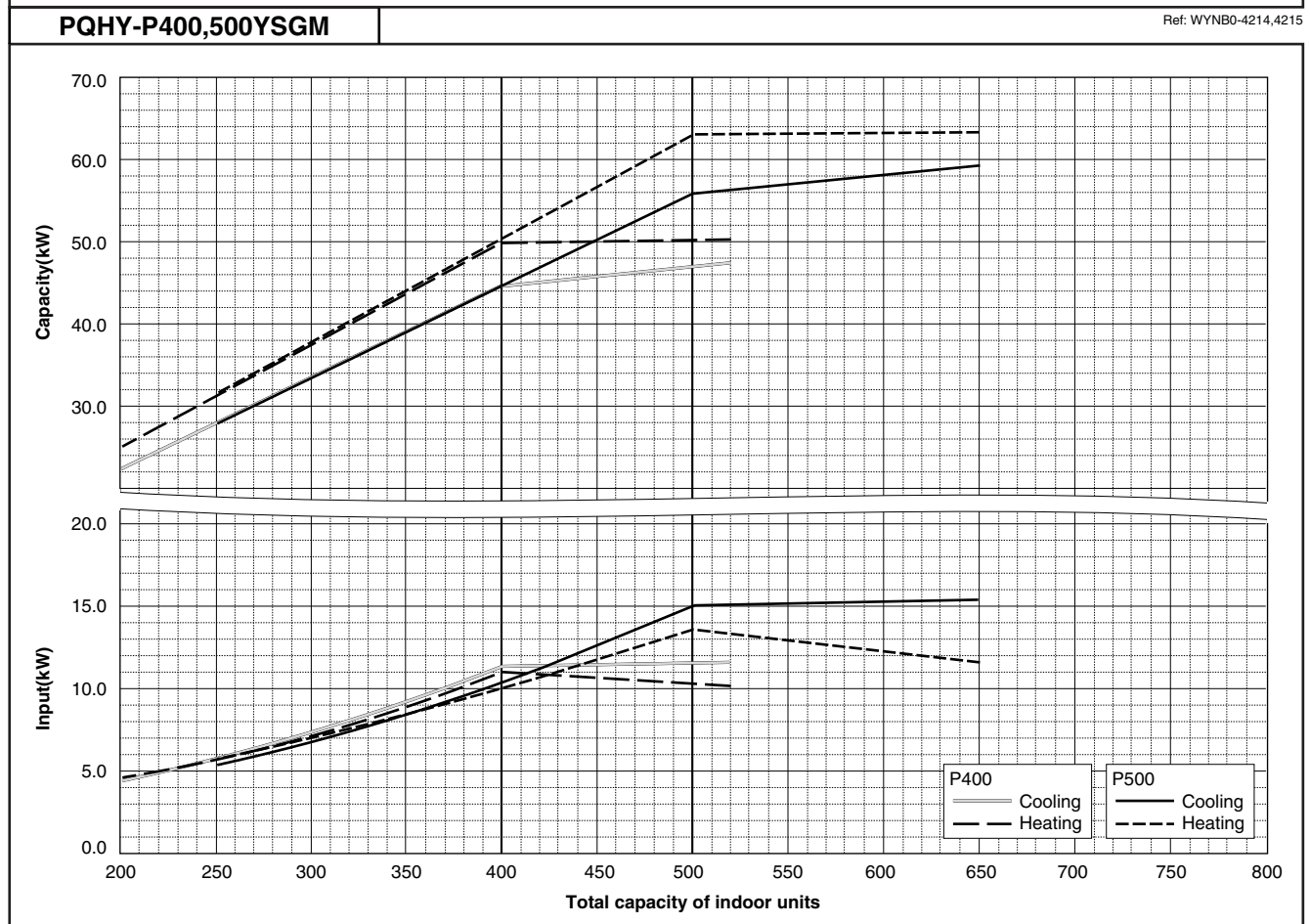
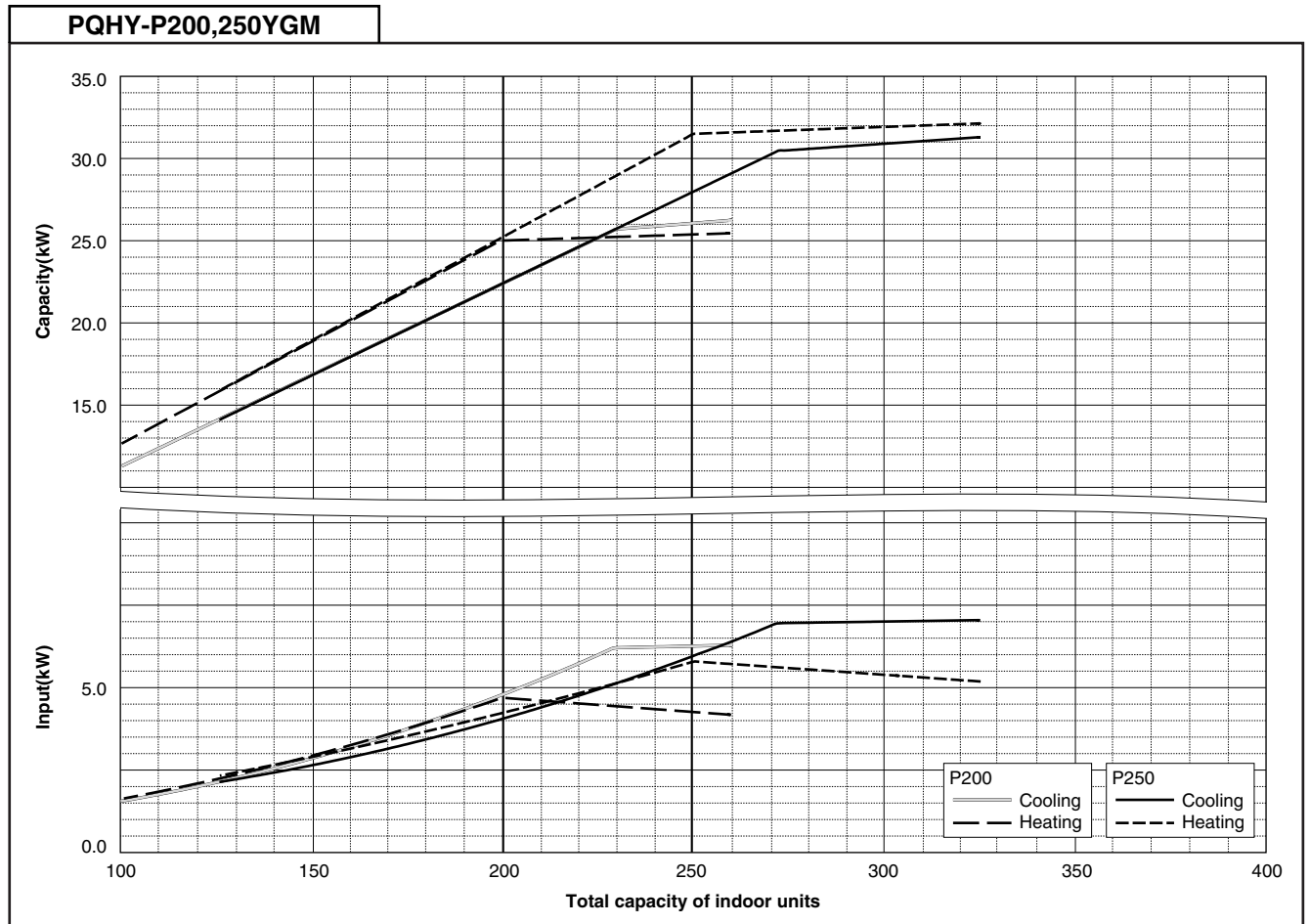

## 2-3. Correction by refrigerant piping length

CITY MULTI™ system can extend the piping flexibly within its limitation for the actual situation. Yet, a decrease of cooling/heating capacity could happen correspondently. Using following correction factor according to the equivalent length of the piping shown at 2.3a and 2.3b, the capacity can be observed. 2.3c shows how to obtain the equivalent length of piping.

### 2-3a. Cooling capacity correction

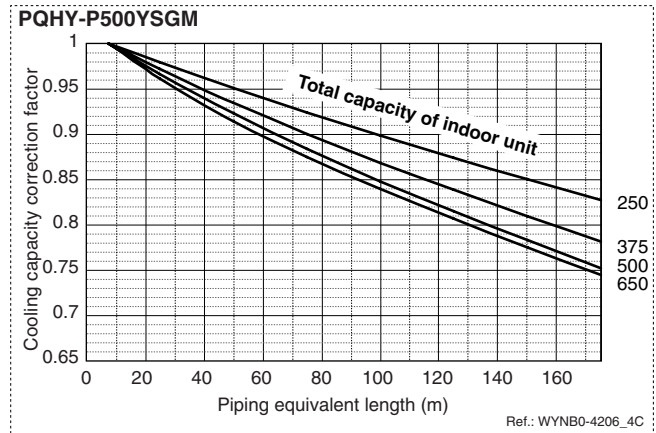
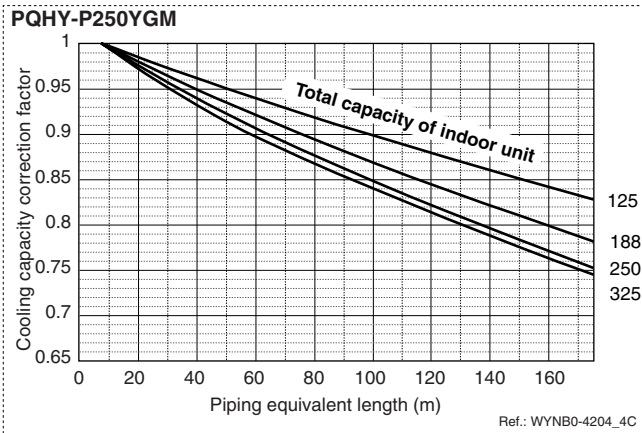
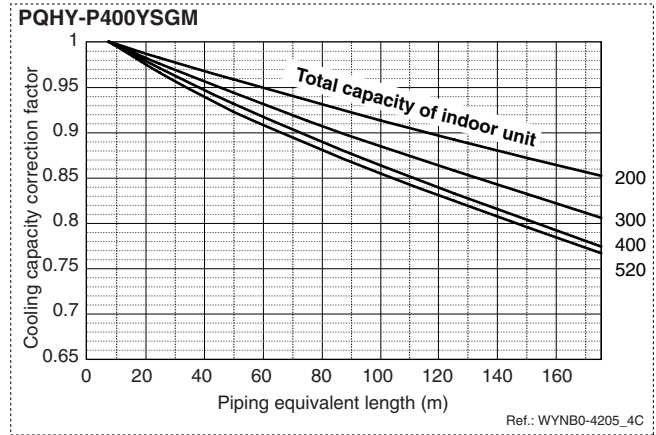
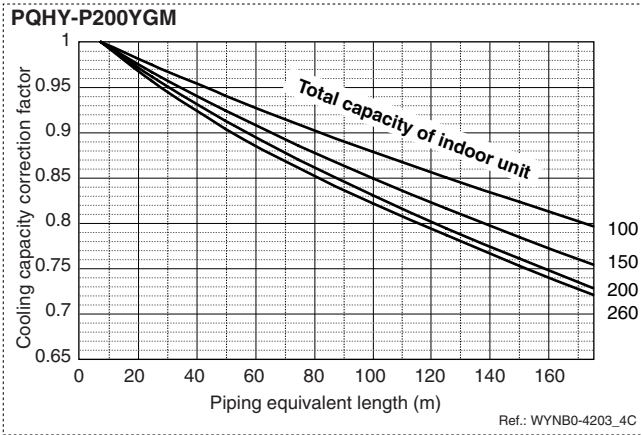

### 2-3. Correction by refrigerant piping length

CITY MULTI™ system can extend the piping flexibly within its limitation for the actual situation. Yet, a decrease of cooling/heating capacity could happen correspondently. Using following correction factor according to the equivalent length of the piping shown at 2.3a and 2.3b, the capacity can be observed. 2.3c shows how to obtain the equivalent length of piping.

#### 2-3b. Heating capacity correction

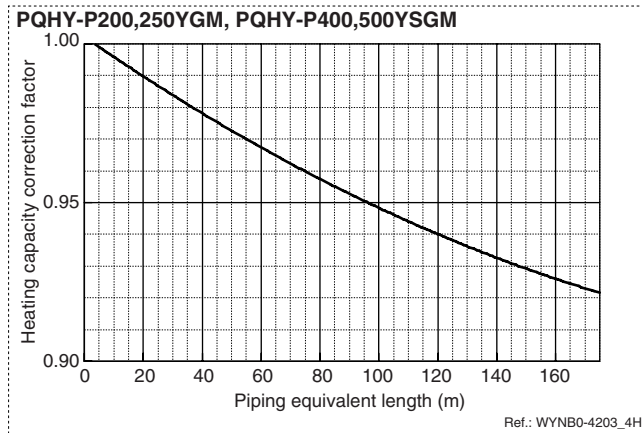

#### 2-3c. How to obtain the equivalent length of piping

- 1 PQHY, PQRYP-200YGM**  
Equivalent length = (Actual piping length to the farthest indoor unit) + (0.47 x number of bent on the piping) m
- 2 PQHY, PQRYP-250YGM**  
Equivalent length = (Actual piping length to the farthest indoor unit) + (0.50 x number of bent on the piping) m
- 3 PQHY, PQRYP-400YSGM**  
Equivalent length = (Actual piping length to the farthest indoor unit) + (0.50 x number of bent on the piping) m
- 4 PQHY, PQRYP-500YSGM**  
Equivalent length = (Actual piping length to the farthest indoor unit) + (0.50 x number of bent on the piping) m

2-4. Temp. range of running

• Cooling

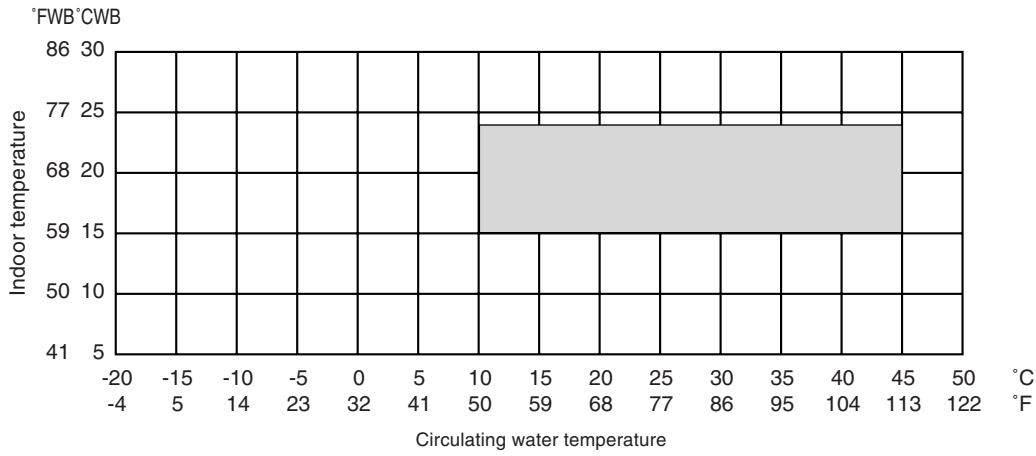

• Heating

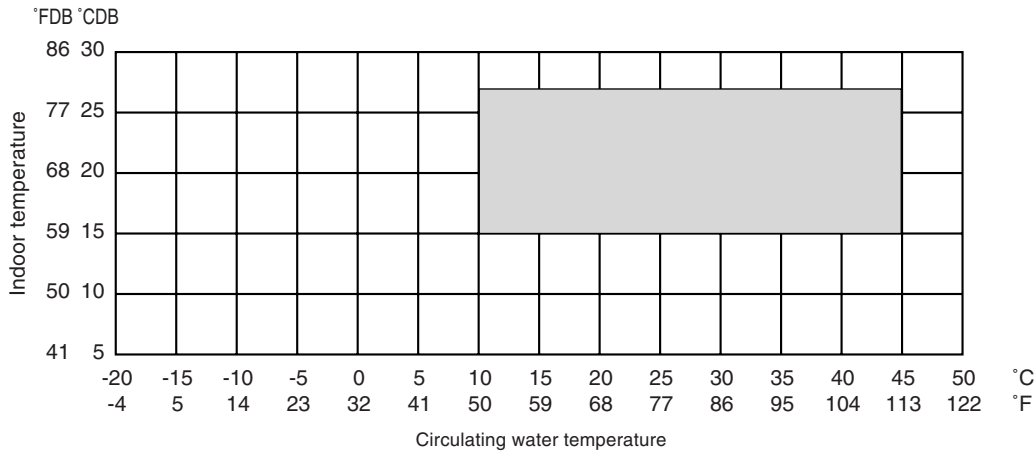

Ref.: tr-ygm-w

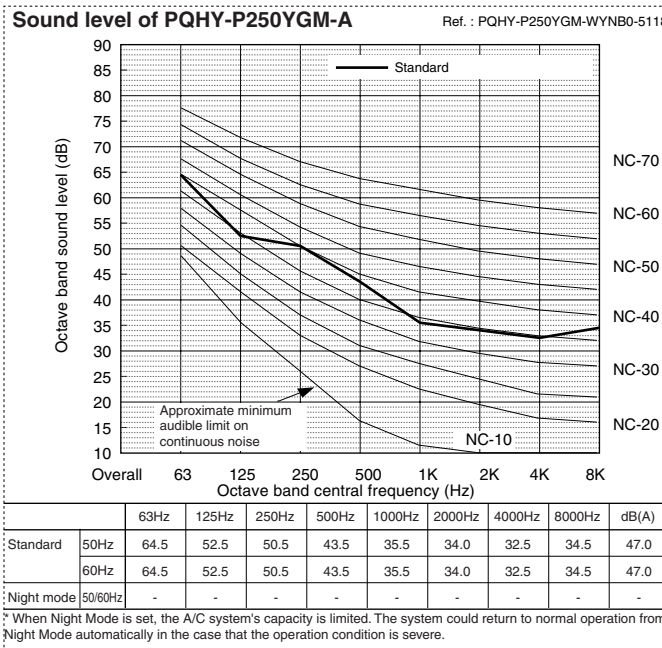
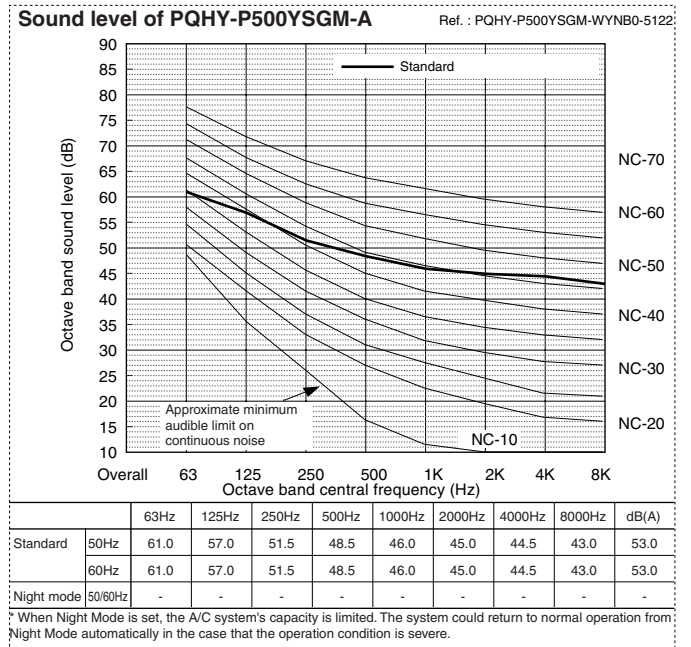
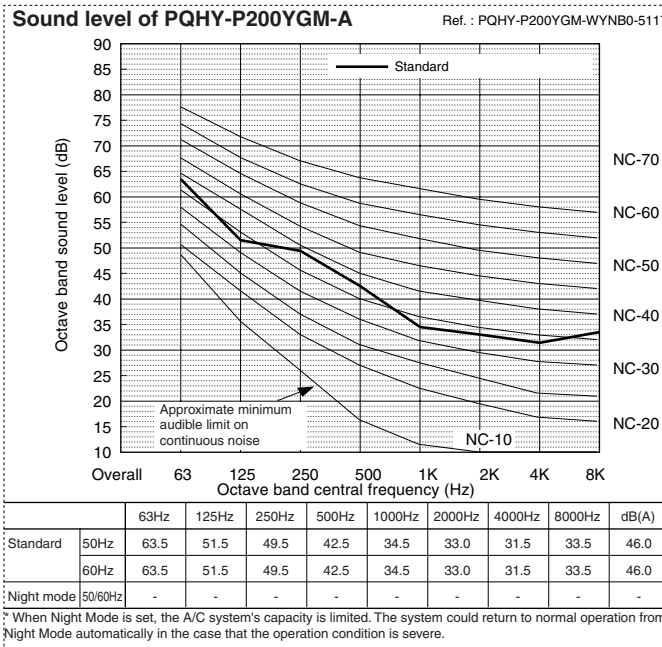
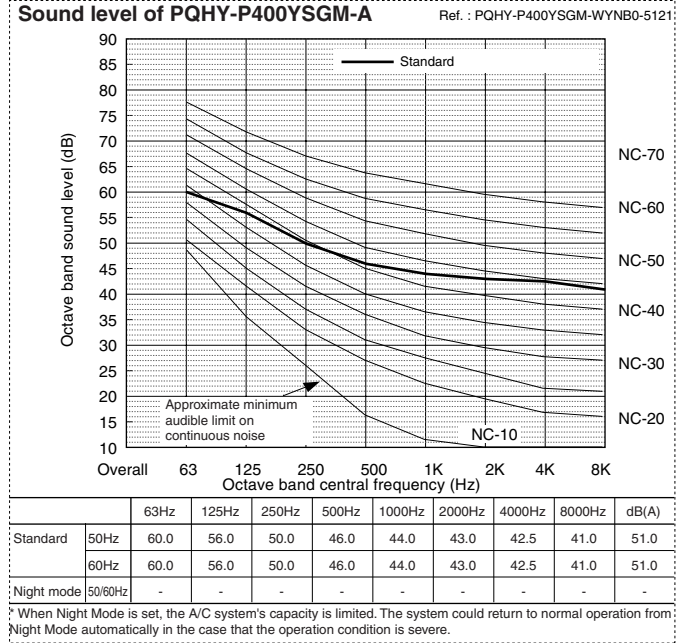
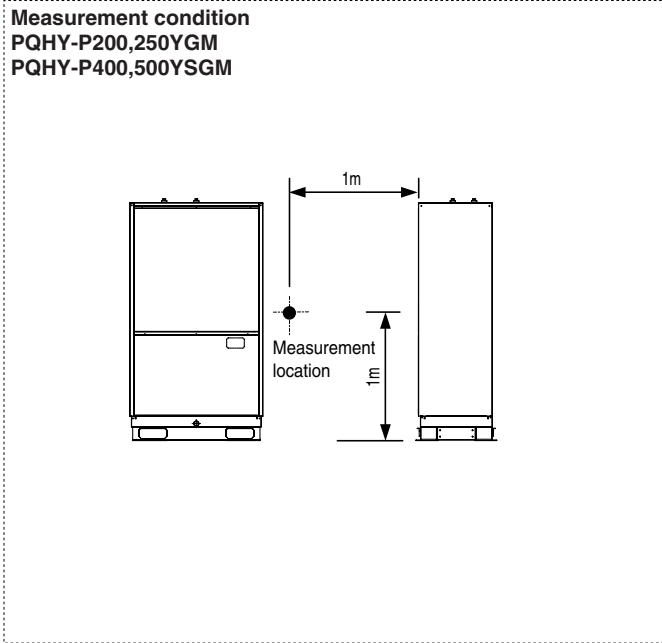

PQHY-P200,250YGM-A

Drw. : OU-W663145  
Unit : mm

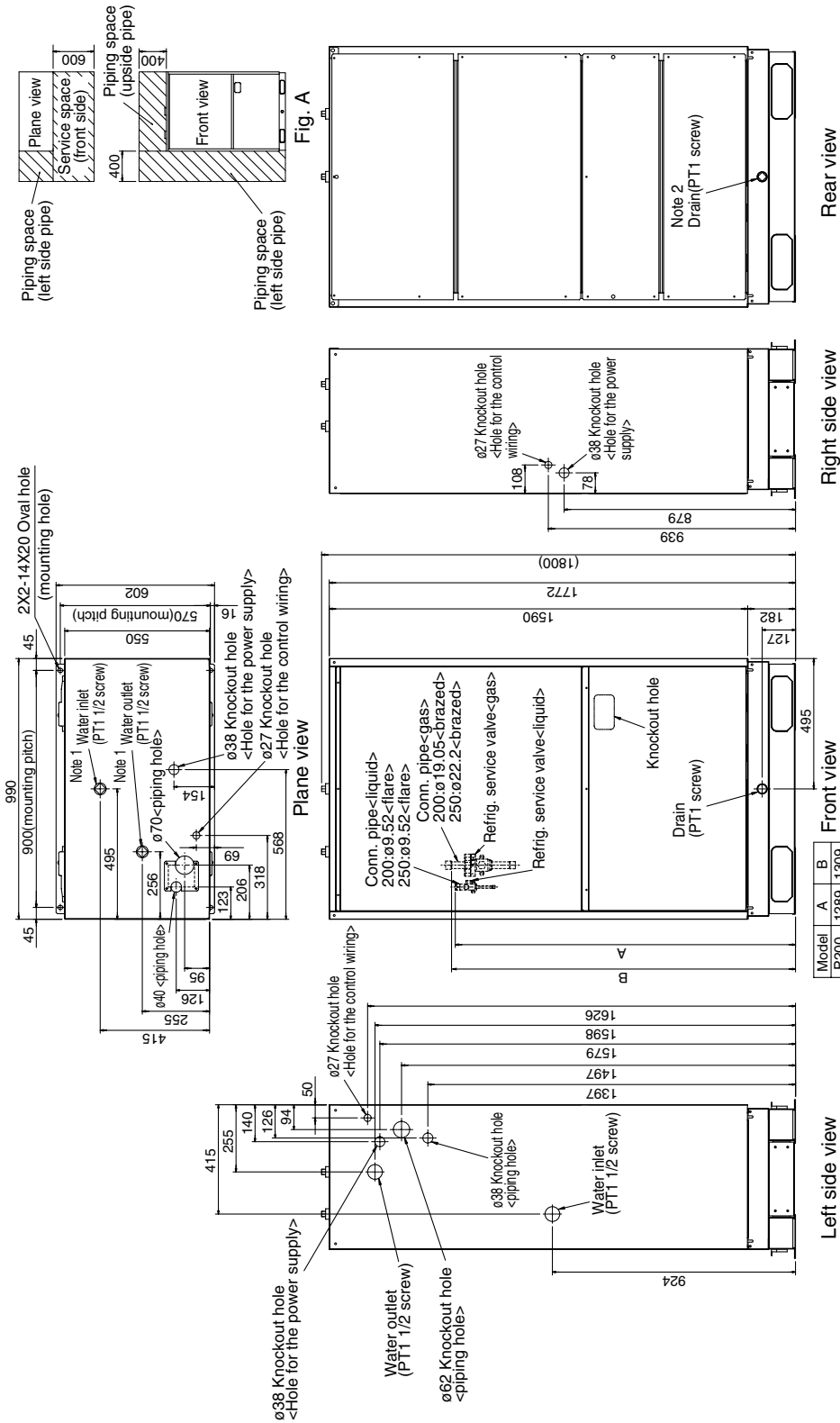

- [Accessories]
- Refrigerant (gas) conn. pipe..... 1pc.  
(Already installed on the unit)
  - Packing for conn. pipe..... 1pc.  
(Attached near the ball valve)
  - Bushing..... 2pcs.
- Note 1. Close a hole of the water piping, the refrigerant piping, the power supply, and the control wiring and unused knockout holes with the putty etc. so as not to infiltrate rain water etc. (field erection work).
- Note 2. At the time of product shipment, the front side piping specification serves as the local drainage connection. When connecting on the rear side, please remove the rear side plug sealing corks, and attach a front side. Ensure there is no leak after the attachment has been fitted.
- Note 3. Take notice of service space as Fig. A. (In case of single installation, 600mm or more of back space as front space makes easier access when servicing the unit from rear side.)
- Note 4. In case the temperature around the Heat source unit has possibility to drop under 0°C, be careful for the following point to prevent the pipe burst by the water pipe freeze-up.  
-Circulate the water all the time even if the Heat source unit is not in operation.  
-Drain the water from inside of the Heat source unit when the Heat source unit will not operate for a long term.

## PQHY-P400,500YSGM-A

Draw. : OU-W663147  
Unit : mm

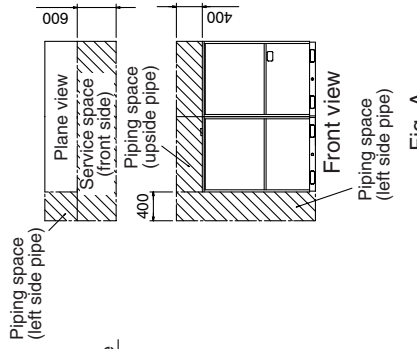
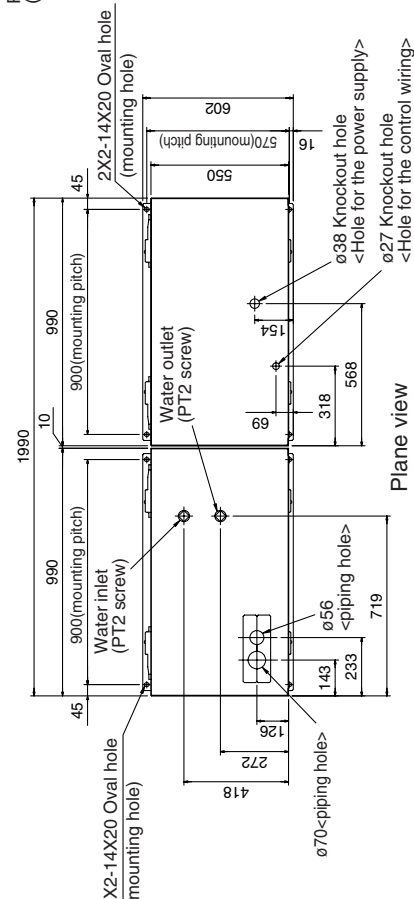
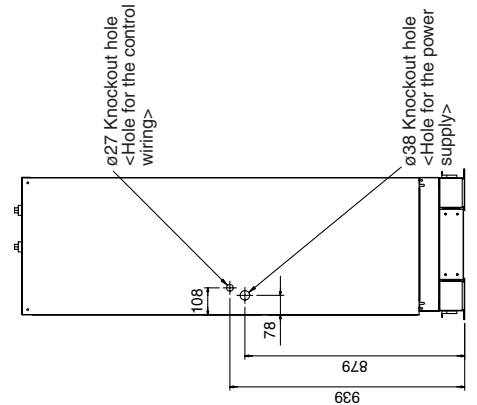

Fig. A



Plane view



Right side view

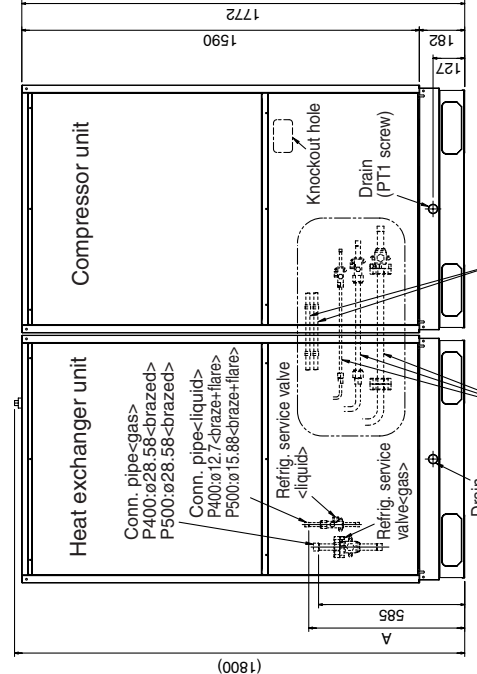

Front view

Model	A
400	624
500	569

Connecting pipes are not provided with the 500 models.

- [Accessories]
- Refrigerant (gas) conn. pipe.....1pc.  
(Already installed on the unit)
  - Refrigerant (liquid) conn. pipe.....1pc.  
(P400 Only ; Packaged in the accessory kit)
  - Refrigerant conn. pipe between Heat exchanger unit and Compressor unit ø9.52.....2pcs.  
(Packaged in the accessory kit)
  - Packing for conn. pipe.....2pcs.  
(Packaged in the accessory kit)
  - Refrigerant conn. pipe.....2pcs.  
(Already installed on the unit)
  - Packing for conn. pipe.....3pcs.  
(Attached near the Ball valve)
  - Bushing.....2pcs.
  - External heater adapter.....1set

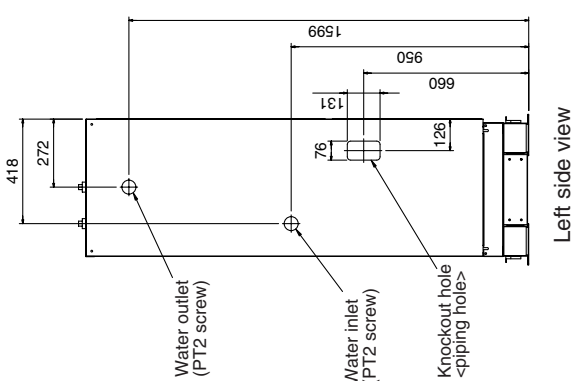

Left side view

1. Close a hole of the water piping, the refrigerant piping, the power supply, and the control wiring and unused knockout holes with the putty etc. so as not to infiltrate rain water etc. (field erection work).
2. At the time of product shipment, the front side piping specification serves as the local drainage connection. When connecting on the rear side, please remove the rear side plug sealing corks, and attach a front side. Ensure there is no leak after the attachment has been fitted.
3. Take notice of service space as Fig. A. (In case of single installation, 600mm or more of back space as front space makes easier access when servicing the unit from rear side.)
4. In case the temperature around the Heat source unit has possibility to drop under 0°C, be careful for the following point to prevent the pipe burst by the water pipe freeze-up.
  - Circulate the water all the time even if the Heat source unit is not in operation.
  - Drain the water from inside of the Heat source unit when the Heat source unit will not operate for a long term
5. Use the external heater adapter for water Heat source (option) to take length (more than 2m) between Heat exchanger unit and Compressor unit.

PQHY-P200,250YGM-A,P400,500YSGM-A

Draw. : OU-W274643

<Symbol explanation>

Symbol	Name
ACCT	AC Current Sensor
DCCT	DC Current Sensor
DCL	DC reactor (Power factor improvement)
52C	Magnetic contactor (Inverter main circuit)
MF1	Fan motor (Radiator panel)
21S4a	Case heater (Compressor)
SV1	Solenoid valve (Discharge-suction bypass)
SV4a,b,c,d	Solenoid valve (Heat exchanger capacity control)
SV5a,b	Solenoid valve (Heat exchanger capacity control)
SV7a,b,c	Solenoid valve (Heat exchanger capacity control)
LEV1	Electronic expansion valve (Sub-cool coil bypass)
LEV2	Electronic expansion valve (Heat exchanger for inverter)
TH11	Thermistor (Discharge pipe temp. detect)
TH5	Compressor (Water temp. detect)
TH6	Water temp. detect
TH7	Liquid outlet temp. detect at sub-cool
TH8	Bypass outlet temp. detect at sub-cool
TH9	Freeze prevention sensor at sub-cool
THINV	Outlet temp. detect of inverter for radiator
THHS1	Radiator panel temp. detect
63H	High pressure switch
63HS	High pressure sensor
63LS	Low pressure sensor
L1L2	Choke coil (Transmission)
Z20	Function device
⊕	Earth terminal

<Difference of appliances>

Model name	-#2	-#3
PQRY-P200P250YGM-A	X	X
PQRY-P400P500YSGM-A		X
PQHY-P200P250YGM-A		X
PQHY-P400P500YSGM-A		X

※1: Function according to switch operation.  
 (SW4-7:CN3D 1-2P and CN3D 1-3P,  
 SW3-3:CN51 3-5P)  
 SW4-7:OFF (Compressor ON/OFF and NIGHT MODE)

CN3D	Compressor	CN3D	NIGHT MODE
1-3P	ON/OFF	1-2P	MODE
OPEN	ON	OPEN	OFF
SHORT	OFF	SHORT	ON

SW4-7:ON (STEP DEMAND)

CN3D 1-3P	CN3D 1-2P	OPEN	SHORT
OPEN	100%	75%	50%
SHORT		0%	

SW3-3	CN51 2-5P
ON	water freeze signal
OFF	trouble signal

※4: Auto change over (CN3N 1-2P, 1-3P);PQHY only

CN3N 1-3P	CN3N 1-2P	OPEN	SHORT
OPEN	Auto change over:OFF		
SHORT	Auto change over:ON	COOL	HEAT

※5: " is on the Heat exchanger unit side for P400/500 type.

NOTE:The broken lines indicate field wiring.

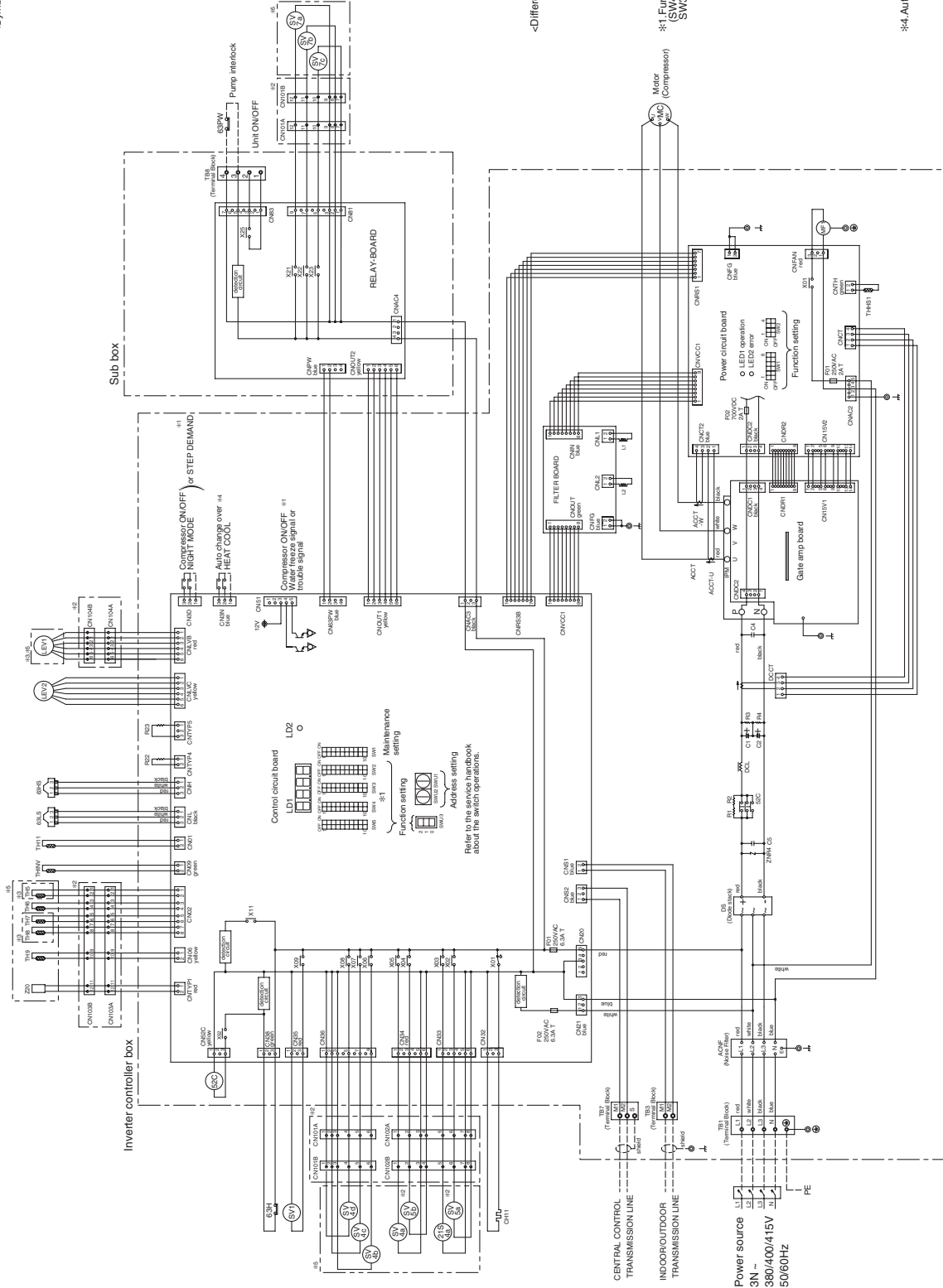



PQHY-P200,250YGM-A

Draw. : RC\_WYNA1-1133-13

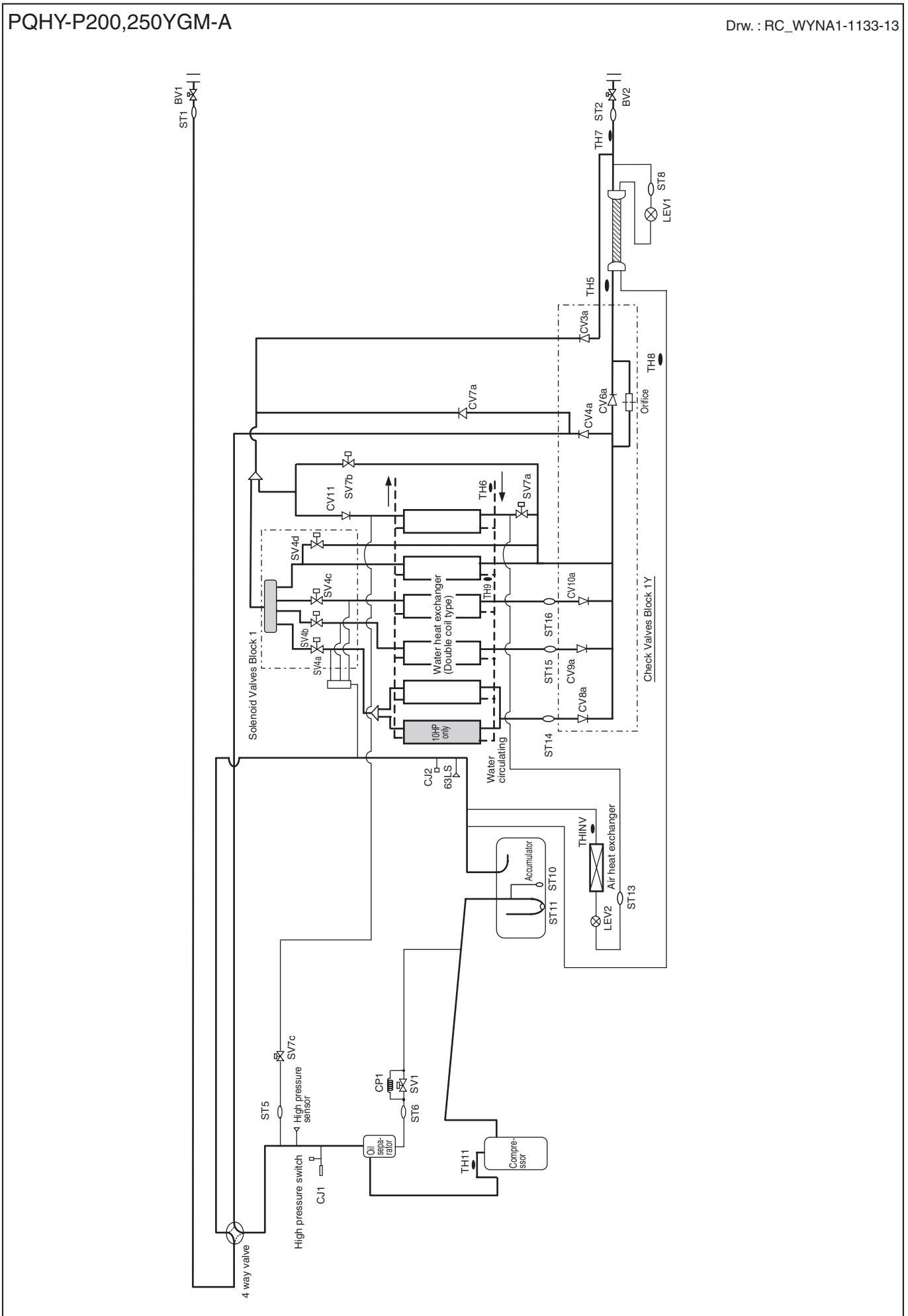

PQHY-P400,500YSGM-A

Drw. : RC\_WYNA3-1133-14

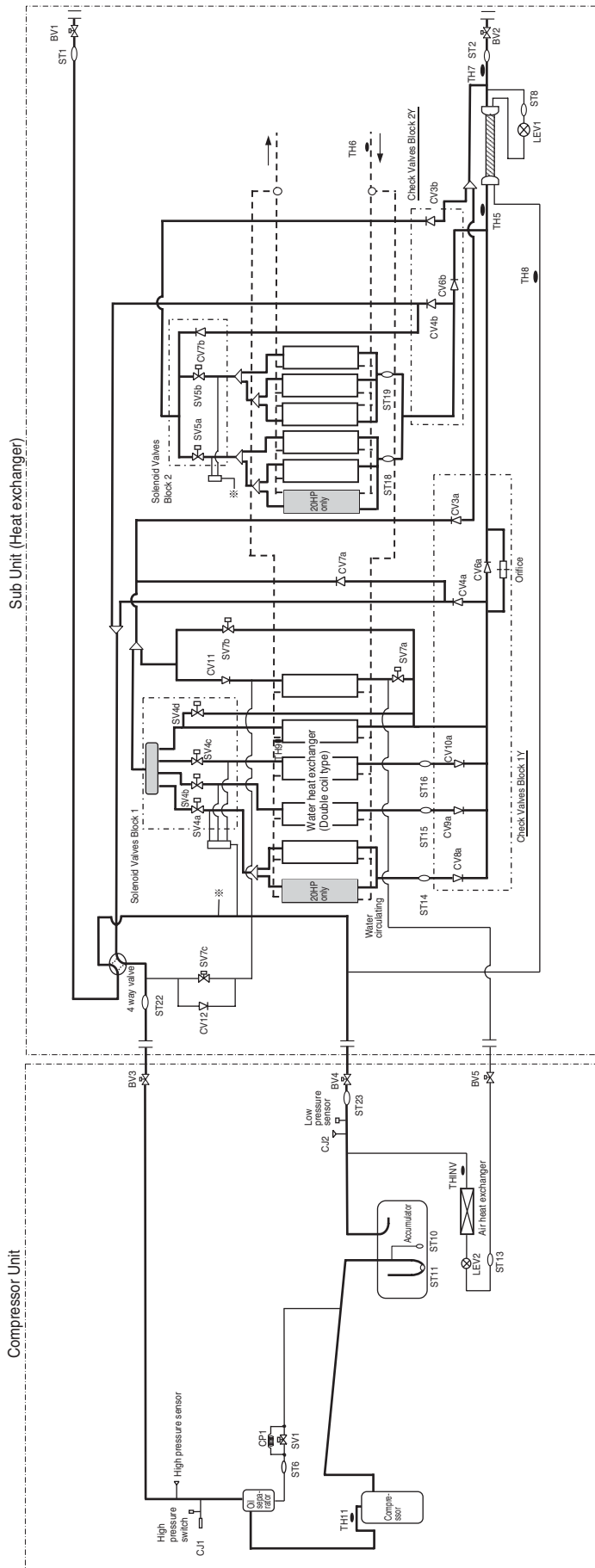

7-1. Designing of water circuit system

1) Example of basic water circuit

The water circuit of the water heat source CITY MULTI connects the heat source unit with the cooling tower/auxiliary heat source/heat storage tank/circulation pump with a single system water piping as shown in the figure below. The selector valve automatically controls to circulate water toward the cooling tower in the cooling season, while toward the heat storage tank in the heating season. If the circulation water temperature is kept in a range of 10~45°C\* regardless of the building load, the water heat source CITY MULTI can be operated for either cooling or heating. Therefore in the summer when only cooling load exists, the temperature rise of circulation water will be suppressed by operating the cooling tower. While in the winter when heating load increases, the temperature of circulation water may be dropped below 10°C. Under such situation, the circulation water will be heated with the auxiliary heat source if it drops below a certain temperature. When the thermal balance between cooling and heating operation is in a correct proportion, the operation of the

auxiliary heat source and cooling tower is not required. In order to control the above thermal balance properly and use thermal energy effectively, utilizing of heat storage tanks, and night-time discounted electric power as a auxiliary heat source will be economical. Meantime as this system uses plural sets of heat source unit equipped with water heat exchangers, water quality control is important. Therefore it is recommended to use closed type cooling towers as much as possible to prevent the circulation water from being contaminated. When open type cooling towers are used, it is essential to provide proper maintenance control such as that to install water treatment system to prevent troubles caused by contaminated circulation water.

\*10~45°C : 50%~130% of indoor units can be connected

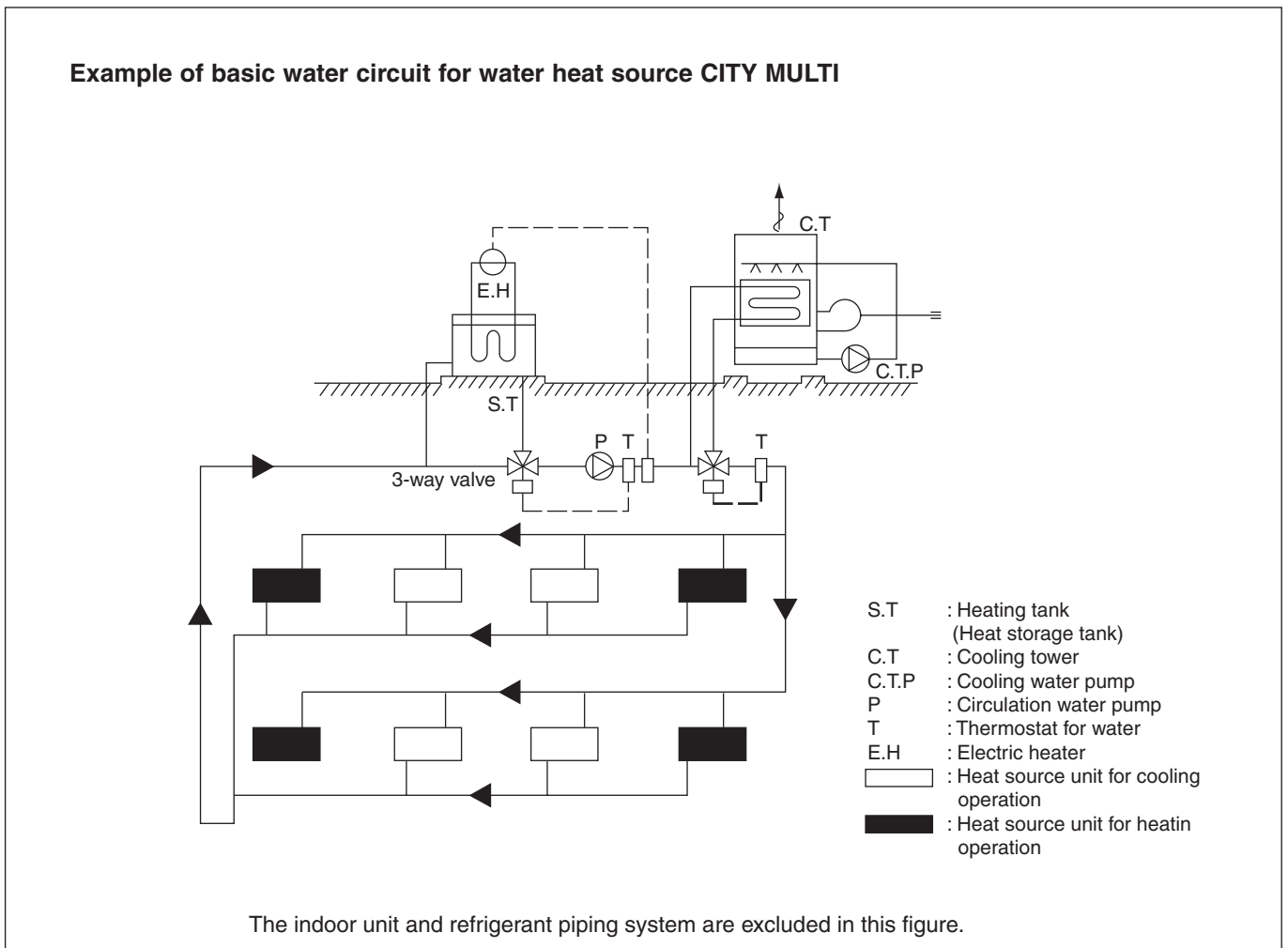

2) Cooling tower

a) Types of cooling tower

The cooling towers presently used include the open type cooling tower, open type cooling tower + heat exchanger, closed type cooling tower, and air-cooled type cooling tower. However, as the quality control of circulation water is essential when units are installed in decentralized state inside a building, the closed type cooling tower is generally employed in such case.

Although the circulation water will not be contaminated by atmospheric air, it is recommended to periodically blow water inside the system and replenish fresh water instead.

In a district where the coil may be frozen in the winter, it is necessary to apply antifreeze solution to the circulation water, or take freeze protection measures such as to automatically discharge water inside the cooling coil at the stopping of the pump.

When the open type cooling tower is used, be sure to install a water quality control device in addition to the freeze protection measures, as the water may be deteriorated by atmospheric contaminants entered into the cooling tower and dissolved into the circulation water.

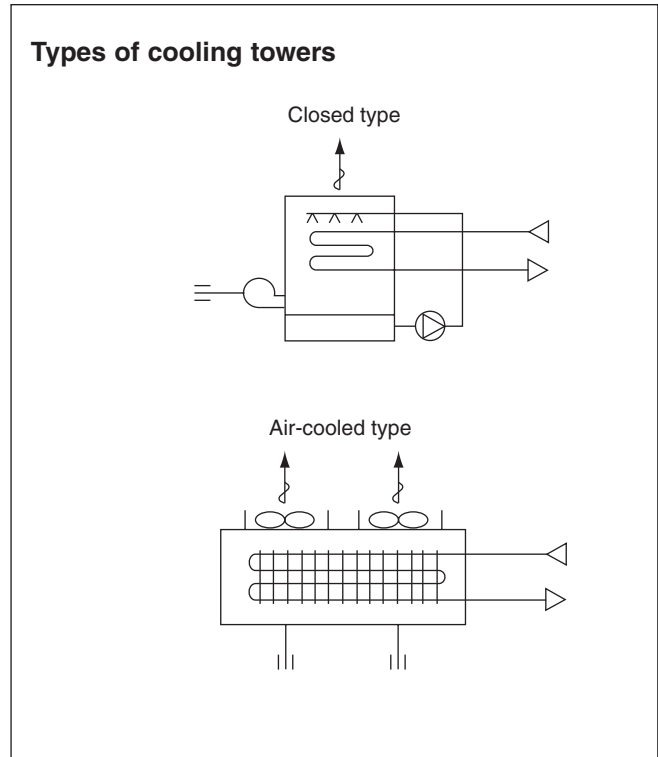

b) Calculation method of cooling tower capacity

All units of the water heat source CITY MULTI may possibly be in cooling operation temporarily (at pulling down) in the summer, however, it is not necessary to determine the capacity according to the total cooling capacity of all CITY MULTI units as this system has a wide operating water temperature range (10~45°C).

It is determined in accordance with the value obtained by adding the maximum cooling load of an actual building, the input heat equivalent value of all CITY MULTI units, and the cooling load of the circulating pumps. Please check for the values of the cooling water volume and circulation water volume.

$$\text{Cooling tower capacity} = \frac{Q_c + 860 \times (\sum Q_w + P_w)}{3,900} \quad (\text{Refrigeration ton})$$

- Q<sub>c</sub> : Maximum cooling load under actual state (kcal/h)
- Q<sub>w</sub> : Total input of water heat source CITY MULTI at simultaneous operation under maximum state (kW)
- P<sub>w</sub> : Shaft power of circulation pumps (kW)

### 3) Auxiliary heat source and heat storage tank

When the heating load is larger than the cooling load, the circulation water temperature lowers in accordance with the heat balance of the system. It should be heated by the auxiliary heat source in order to keep the inlet water temperature within the operating range (10°C or more) of the water heat source CITY MULTI.

Further in order to operate the water heat source CITY MULTI effectively, it is recommended to utilize the heat storage tank to cover the warming up load in the morning and the insufficient heat amount.

Effective heat utilization can be expected to cover insufficient heat at the warming up in the next morning or peak load time by storing heat by installing a heat storage tank or operating a low load auxiliary heat source at the stopping of the water heat source CITY MULTI. As it can also be possible to reduce the running cost through the heat storage by using the discounted night-time electric power, using both auxiliary heat source and heat storage tank together is recommended.

#### Determining the auxiliary heat source capacity

For the CITY MULTI water heat source system, a heat storage tank is recommended to use. When employment of the heat storage tank is difficult, the warming up operation should be arranged to cover the starting up heating load. Since the holding water inside the piping circuit owns heat capacity and the warming up operation can be assumed for about one hour except that in a cold region, the heat storage tank capacity is required to be that at the maximum daily heating load including the warming up load at the next morning of the holiday.

The effective temperature difference of an ordinary heat storage tank shows about 5deg. even with the storing temperature at 45°C.

However with the water heat source CITY MULTI, it can be utilized as heating heat source up to 15°C with an effective temperature of a high 30deg. approximately, thus the capacity of the heat storage tank can be minimized.

#### a)Auxiliary heat source

The following can be used as the auxiliary heat source.

- Boiler (Heavy oil, kerosine, gas, electricity)
- Electric heat (Insertion of electric heater into heat storage tank)
- Outdoor air (Air-heat source heat pump chiller)
- Warm discharge water (Exhaust water heat from machines inside building and hot water supply)
- Utilization of night-time lighting
- Solar heat

Please note that the auxiliary heat source should be selected after studying your operating environment and economical feasibility.

However the auxiliary heat source capacity should be determined by the daily heating load including warming up load on the week day.

For the load at the next morning of the holiday, heat storage is required by operating the auxiliary heat source even outside of the ordinary working hour.

#### When heat storage tank is not used

$$QH = HC_T \left( 1 - \frac{1}{COP_h} \right) - 1000 \times V_w \times \Delta T - 860 \times P_w$$

QH	: Auxiliary heat source capacity	(kcal/h)
HC <sub>T</sub>	: Total heating capacity of each water heat source CITY MULTI	(kcal/h)
COP <sub>H</sub>	: COP of water heat source CITY MULTI at heating	
V <sub>w</sub>	: Holding water volume inside piping	(m <sup>3</sup> )
ΔT	: Allowable water temperature drop = T <sub>WH</sub> - T <sub>WL</sub>	(°C)
T <sub>WH</sub>	: Heat source water temperature at high temperature side	(°C)
T <sub>WL</sub>	: Heat source water temperature at low temperature side	(°C)
P <sub>w</sub>	: Heat source water pump shaft power	(kW)

When heat storage tank is used;

$$QH = \frac{HQ_{1T} \left( 1 - \frac{1}{COP_h} \right) - 860 \times P_w \times T_2}{T_1} \times K \quad (\text{Kcal})$$

- QH<sub>1T</sub> : Total of heating load on weekday including warming up (kcal/day)
- T<sub>1</sub> : Operating hour of auxiliary heat source (h)
- T<sub>2</sub> : Operating hour of heat source water pump (h)
- K : Allowance factor (Heat storage tank, piping loss, etc.) 1.05~1.10

HQ<sub>1T</sub> is calculated from the result of steady state load calculation similarly by using the equation below.  
 $HQ_{1T} = 1.15 \times (\sum Q'a + \sum Q'b + \sum Q'c + \sum Q'd + \sum Q'f) T_2 - \psi (\sum Q'e_1 + \sum Q'e_2 + \sum Q'e_3) (T_2 - 1)$

- Q'a : Thermal load from external wall/roof in each zone (kcal/h)
- Q'b : Thermal load from glass window in each zone (kcal/h)
- Q'c : Thermal load from partition/ceiling/floor in each zone (kcal/h)
- Q'd : Thermal load by infiltration in each zone (kcal/h)
- Q'f : Fresh outdoor air load in each zone (kcal/h)
- Q'e<sub>1</sub> : Thermal load from human body in each zone (kcal/h)
- Q'e<sub>2</sub> : Thermal load from lighting fixture in each zone (kcal/h)
- Q'e<sub>3</sub> : Thermal load from equipment in each zone (kcal/h)
- ψ : Radiation load rate 0.6~0.8
- T<sub>2</sub> : Air conditioning hour

b) Heat storage tank

Heat storage tank can be classified by types into the open type heat storage tank exposed to atmosphere, and the closed type heat storage tank with structure separated from atmosphere. Although the size of the tank and its installation place should be taken into account, the closed type tank is being usually employed by con-

sidering corrosion problems.

The capacity of heat storage tanks is determined in accordance with the daily maximum heating load that includes warming up load to be applied for the day after the holiday.

When auxiliary heat source is operated during operation and even after stopping of water heat source CITY MULTI unit

$$V = \frac{HQ_{2T} \left( 1 - \frac{1}{COP_h} \right) - 860 \times P_w \times T_2 - QH \times T_2}{\Delta T \times 1000 \times \eta V} \quad (\text{ton})$$

When auxiliary heat source is operated after stopping of water heat source CITY MULTI unit

$$V = \frac{HQ_{2T} \left( 1 - \frac{1}{COP_h} \right) - 860 \times P_w \times T_2}{\Delta T \times 1000 \times \eta V} \quad (\text{ton})$$

- HQ<sub>2T</sub> : Maximum heating load including load required for the day after the holiday (kcal/day)
- ΔT : Temperature difference utilized by heat storage tank (deg)
- ηV : Heat storage tank efficiency

$$HQ_{2T} : 1.3 \times (\sum Q'a + \sum Q'c + \sum Q'd + \sum Q'f) T_2 - \psi (\sum Q'e_2 + \sum Q'e_3) (T_2 - 1)$$

4) Piping system

The following items should be kept in your mind in planning / designing water circuits.

- a) All units should be constituted in a single circuit in principle.
- b) When plural numbers of the water heat source CITY MULTI unit are installed, the rated circulating water flow rate should be kept by making the piping resistance to each unit almost same value. As an example, the reverse return system as shown below may be employed.
- c) Depending on the structure of a building, the water circuit may be prefabricated by making the layout uniform.
- d) When a closed type piping circuit is constructed, install an expansion tank usable commonly for a make-up water

tank to absorb the expansion/contraction of water caused by temperature fluctuation.

- e) If the operating temperature range of circulation water stays within the temperature near the normal temperature (summer : 30°C, winter : 20°C), thermal insulation or anti-sweating work is not required for the piping inside buildings.

In case of the conditions below, however, thermal insulation is required.

- When well water is used for heat source water.
- When piped to outdoor or a place where freezing may be caused.
- When vapor condensation may be generated on piping due to an increase in dry bulb temperature caused by the entry of fresh outdoor air.

Y  
R2  
WY  
WR2  
S  
OP

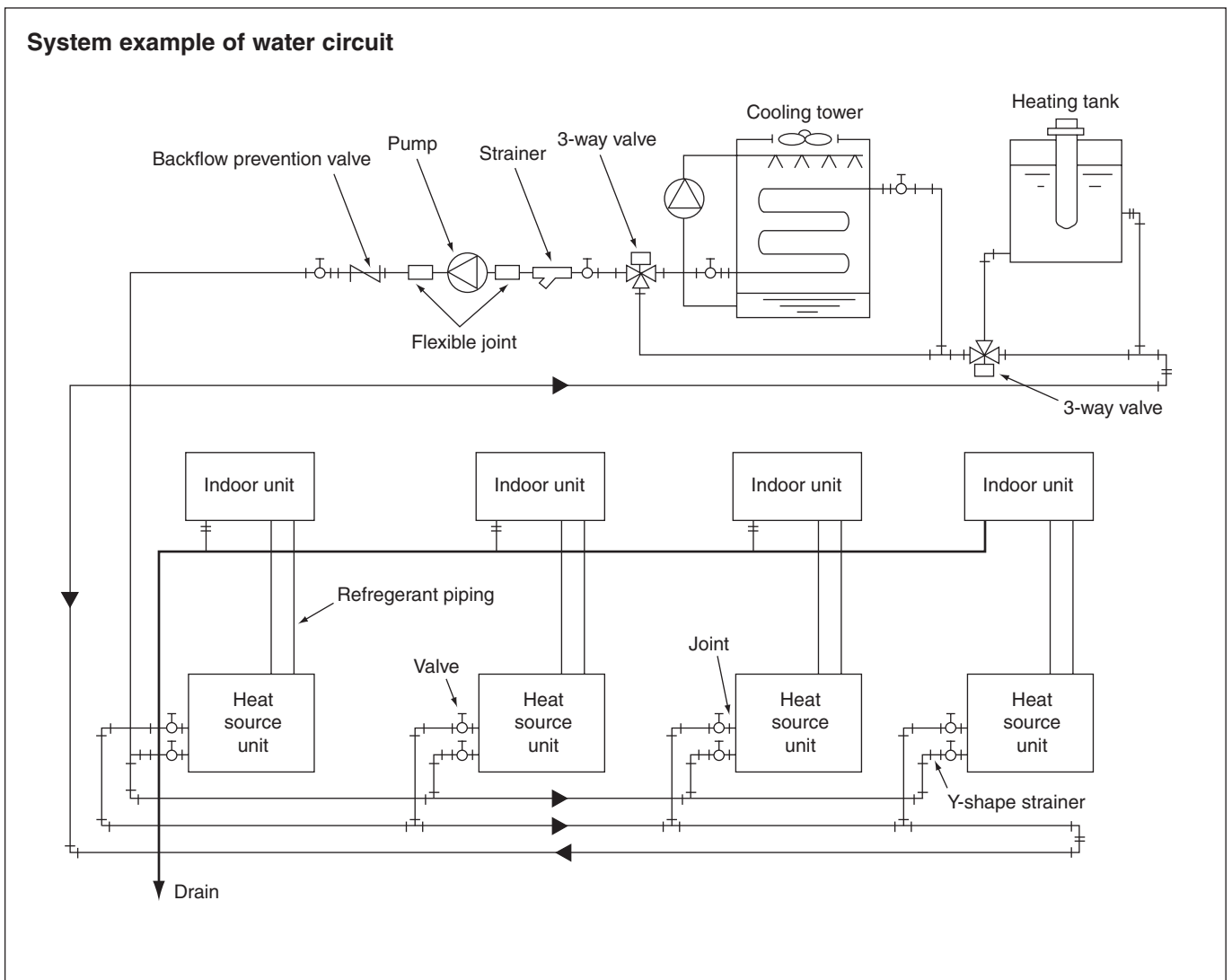

## 5) Cleaning of water heat exchanger

For the water heat exchanger, scale adheres in less amount generally in the case of closed type cooling towers. However in a long period of use, scale will adhere that may lower the heat exchange capacity and increase the water resistance.

In such case, conduct cleaning work under the proce-

cedure given below.

The cleaning work procedure generally used is as follows. However as the cleaning agents have various differences in their cleaning effect, corrosion characteristics, processing time, and condensation for use, conduct the work after consulting the relating maker.



## a) Still standing method

This method feeds the raw liquid or diluted solution of cleaning agent into the water circuit and leave it for a while, and requires only a simple device.

- Since the cleaning time required differs by the agent of each maker, be sufficiently careful for the time and not to exceed the time specified.

- Fully recover the cleaning liquid through the water discharge plug of the heat exchanger, and then fully clean the water circuit with clean water. If the water washing can not be made sufficiently, neutralization processing will be effective.

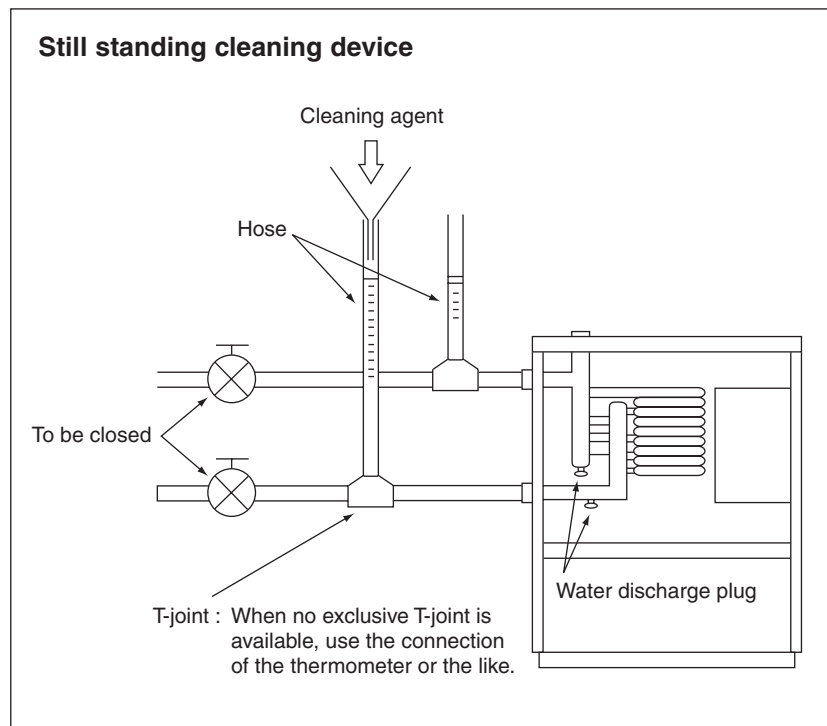



b)Circulation method

Although this method can clean in shorter time than that required by the still standing method, be careful that the circulation pump may be damaged if using cleaning agent with strong corrosive characteristics.

- After completing washing work, fully recover the washing liquid through the water discharge plug installed at the bottom of the piping and that at the heat exchanger.
- Conduct water washing for three times or more after removing cleaning agent. If this can not be made satisfactorily, apply neutralization treatment. Full replacement of water can be ascertained by measuring the PH of the water.
- Note that it may be required to control the cleaning time depending on the scale generation or water quality.
- At cleaning work, remove or shut down the instruments like water pressure gauges so that the cleaning liquid will not enter into them.

- Check for the connections of piping beforehand so that cleaning agent will not leak from the piping during cleaning work.
- Start cleaning operation after fully mixing the cleaning agent with water.
- Cleaning at the earlier timing is recommended as the removal of scale will be difficult if it has accumulated seriously. Periodical cleaning is necessary in a district with inferior water quality.
- Conduct water washing sufficiently with clear water after cleaning work as all cleaning agents own strong acidity.
- To verify the completion of cleaning, remove the hose and observe the inner wall of the piping whether it is clean.
- Be sufficiently careful for fire when using inflammable cleaning agent (GOSPEL R).

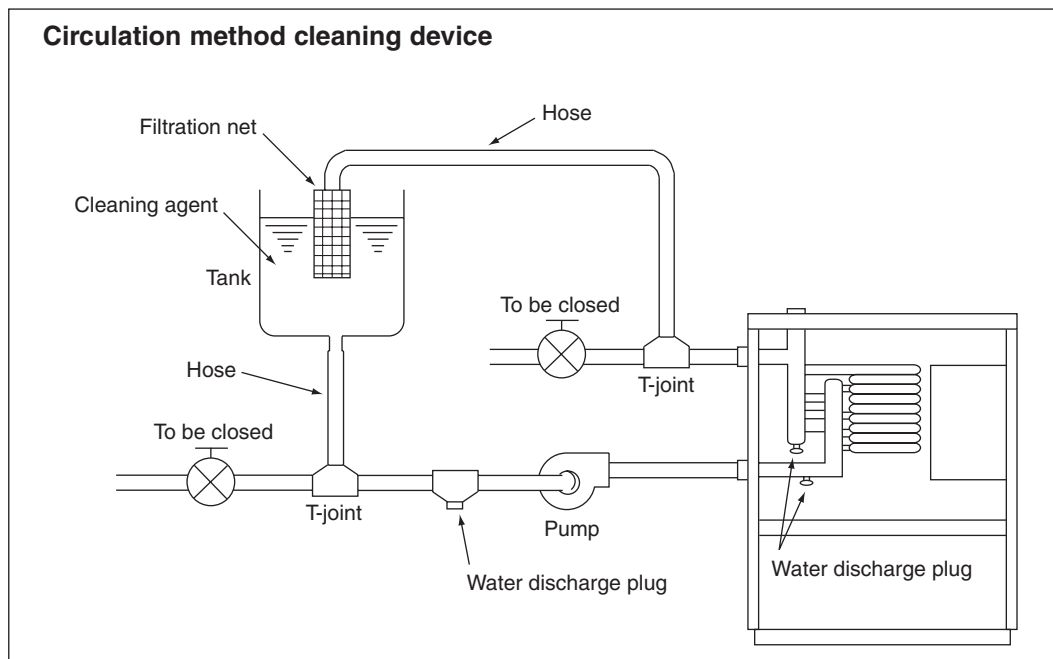

Example of cleaning agents

Name	Shape	Condensation	Time	Makers
CLEARLITE RK	Powder/Liquid	10~20%	2~3Hr.	Koei Kagaku
CLEARLITE ACE	Powder/Liquid	3~5%	1~3Hr.	Koei Kagaku
GOSPEL R	Liquid	7% (Upper limit 10%, ) lower limit 5%)	1~4Hr.	Gospel Kako
GOSPEL SR	Powder			Marusan
ADDITION DR	Powder			Seiwa kogyo
SS-100	Liquid			Saver Kagaku
NEOLUX F	Powder			
DISCALER	Powder	4~7%		

6) Practical System Examples and Circulation Water Control

Since the water heat source CITY MULTI is of water heat source system, versatile systems can be constituted by combining it with various heat sources.

The practical system examples are given below.

Either cooling or heating operation can be performed if the circulation water temperature of the water heat

source CITY MULTI stays within a range of 10~45°C. However, the circulation water temperature near 32°C for cooling and 20°C for heating is recommended by taking the life, power consumption and capacity of the air conditioning units into consideration. The detail of the control is also shown below.

Example-1 Combination of closed type cooling tower and hot water heat storage tank (using underground hollow slab)

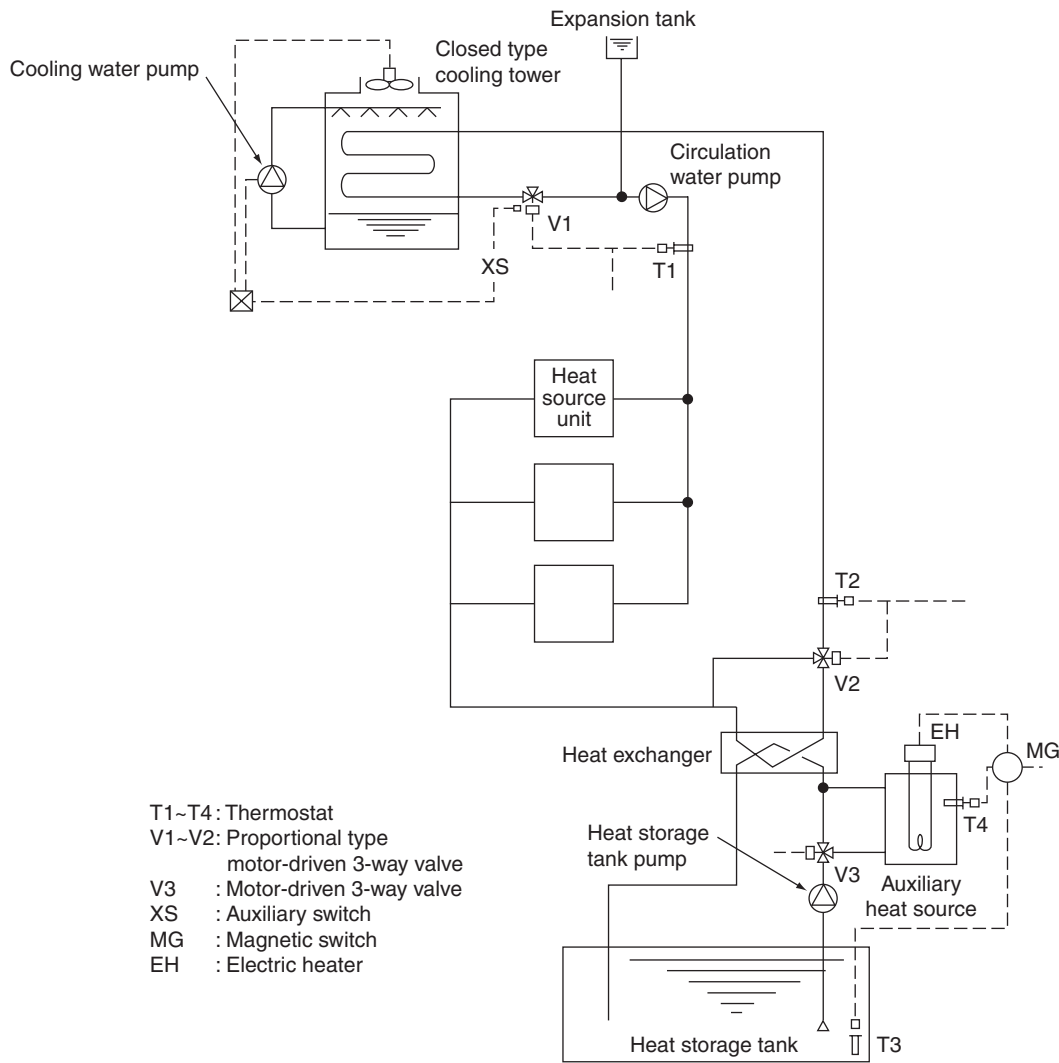

By detecting the circulation water temperature of the water heat source CITY MULTI system with T1 (around 32°C) and T2 (around 20°C), the temperature will be controlled by opening/closing V1 in the summer and V2 in the winter.

In the summer, as the circulation water temperature rises exceeding the set temperature of T1, the bypass port of V1 will open to lower the circulation water temperature. While in the winter, as the circulation water temperature drops, V2 will open following the command of T2 to rise the circulation water temperature.

The water inside the heat storage tank will be heated by the auxiliary heat source by V3 being opened with timer operation in the night-time. The electric heater of the auxiliary heat source will be controlled by T3 and the timer. The start/stop control of the fan and pump of the closed type cooling tower is applied with the step control of the fan and pump following the command of the auxiliary switch XS of V1, that operates only the fan at the light load while the fan and pump at the maximum load thus controlling water temperature and saving motor power.

## Example-2 Combination of closed type cooling tower and hot water heat storage tank

T1 : Proportional type, insertion system thermostat  
 T2 : Proportional type, insertion system thermostat  
 T3 : Proportional type, insertion system thermostat  
 V1 : Proportional type, motor-driven 3-way valve  
 V2 : Proportional type, motor-driven 3-way valve  
 XS : Auxiliary switch (Duplex switch type)  
 SC : Step controller  
 R : Relay  
 MG : Magnetic

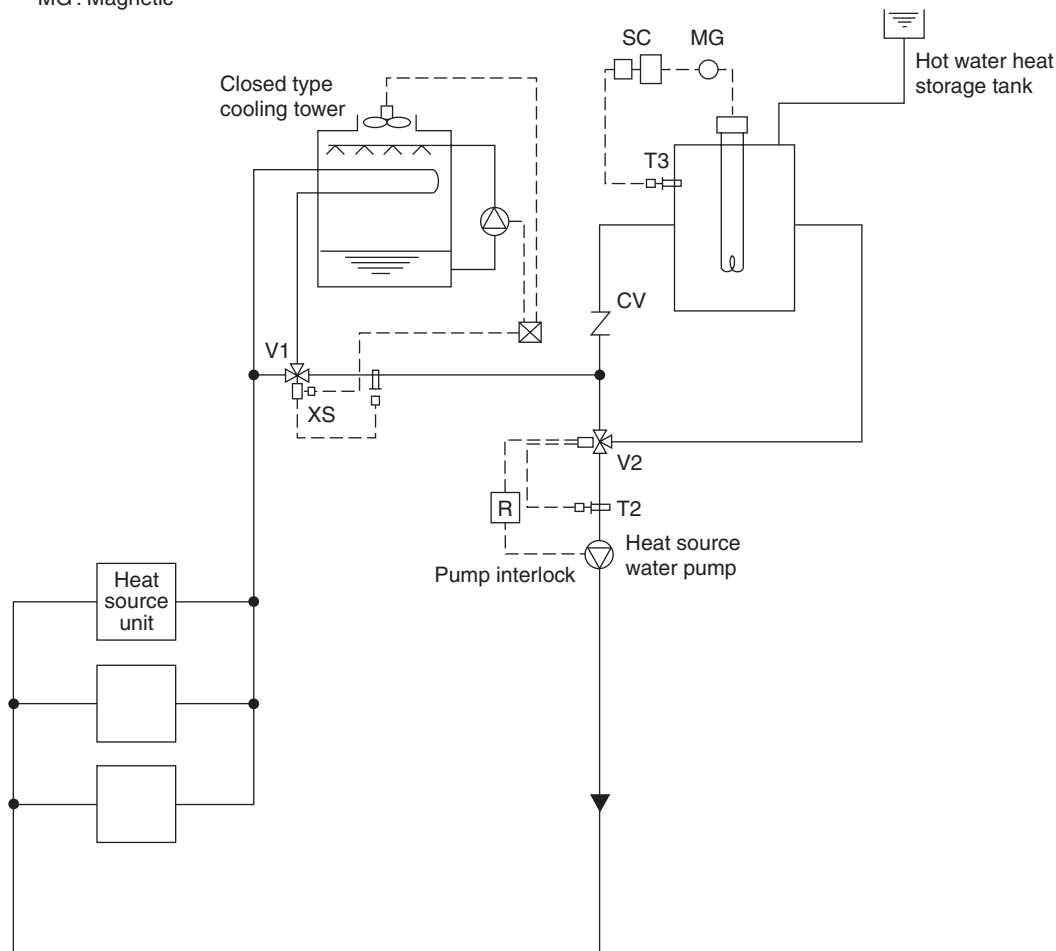

=In the summer, as the circulation water temperature rises exceeding the set temperature of T1, the bypass port of V1 will open to lower the circulation water temperature. In the winter, if the circulation water temperature stays below 25°C, V2 will open/close by the command of T2 to keep the circulation water temperature constant.

The temperature of the hot water inside the heat storage tank will be controlled through the step control of the electric heater by step controller operation following the command of T3.

During the stopping of the heat source water pump, the bypass port of V2 will be closed fully by interlocking thus preventing the high temperature water from entering into the system at the starting of the pump.

The start/stop control of the fan and pump of the closed type cooling tower is applied with the step control of the fan and pump following the command of the auxiliary switch XS of V1, that operates only the fan at the light load while the fan and pump at the maximum load thus controlling water temperature and saving motor power.

## Example-3 Combination of closed type cooling tower and boiler

- T1 : Proportional type, insertion system thermostat  
 T2 : Proportional type, insertion system thermostat  
 T3 : Proportional type, insertion system thermostat  
 V1 : Proportional type, motor-driven 3-way valve  
 S : Selector switch  
 R : Relay  
 XS : Auxiliary switch (Duplex switch type)

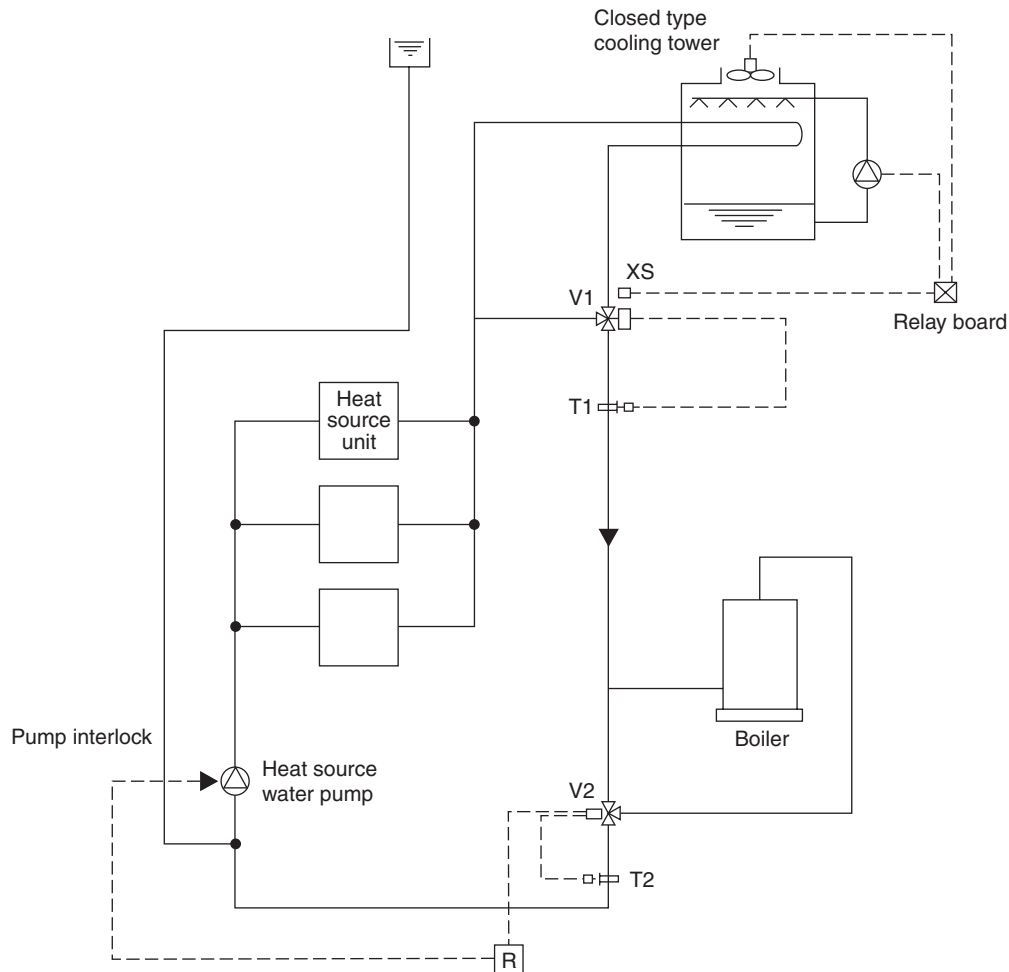

In the summer, as the circulation water temperature rises exceeding the set temperature of T1, the bypass port of V1 will close to lower the circulation water temperature. In the winter, if the circulation water temperature drops below 25°C, V2 will conduct water temperature control to keep the circulation water temperature constant.

During the stopping of the heat source water pump, the bypass port of V2 will be closed fully by interlocking.

The start/stop control of the fan and pump of the closed type cooling tower is applied with the step control following the command of the auxiliary switch XS of V1, thus controlling water temperature and saving motor power.

## Example-4 Combination of closed type cooling tower and heat exchanger (of other heat source)

- T1 : Proportional type, insertion system thermostat  
 T2 : Proportional type, insertion system thermostat  
 V1 : Proportional type, motor-driven 3-way valve  
 V2 : Proportional type, motor-driven 3-way valve  
 S : Selector switch  
 R : Relay  
 XS : Auxiliary switch (Duplex switch type)

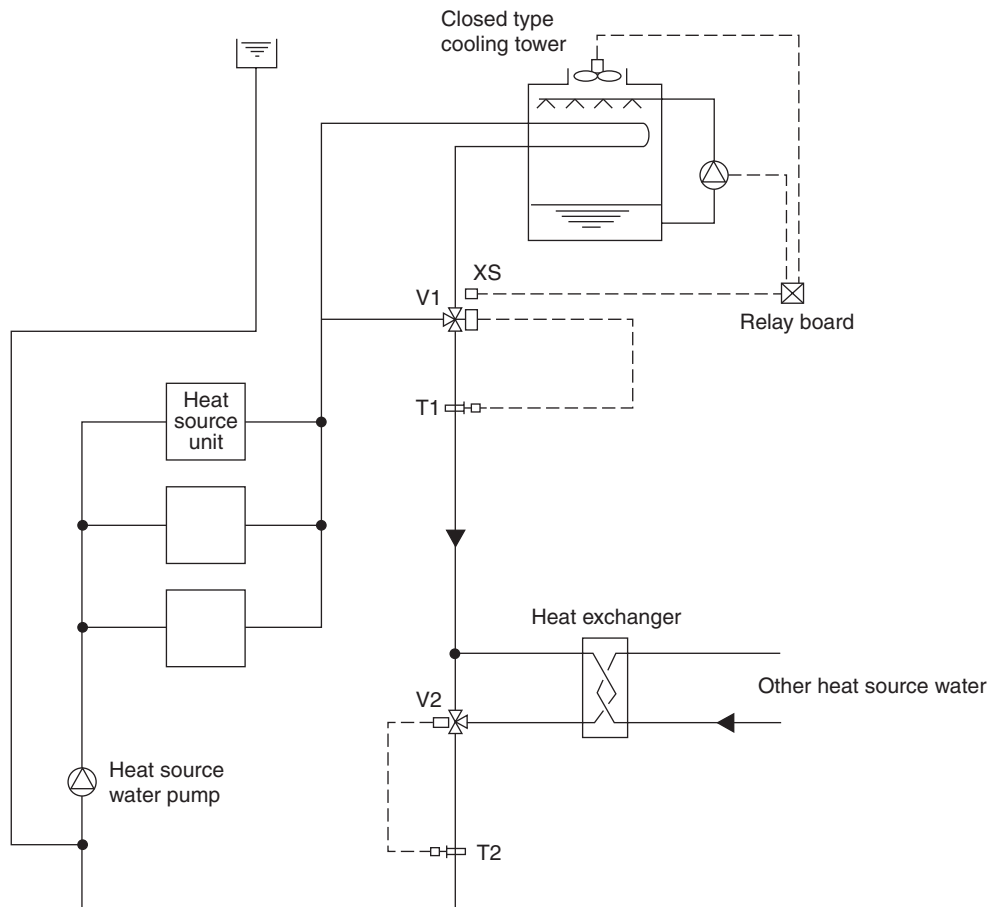

In the summer, as the circulation water temperature rises exceeding the set temperature of T1, the bypass port of V1 will close to lower the circulation water temperature. In the winter, if the circulation water temperature drops below 26°C, V2 will conduct water temperature control to keep the circulation water temperature constant.

During the stopping of the heat source water pump, the bypass port of V2 will be closed fully by interlocking.

The start/stop control of the fan and pump of the closed type cooling tower is applied with the step control following the command of the auxiliary switch XS of V1, thus controlling water temperature and saving motor power.

7) Pump interlock circuit

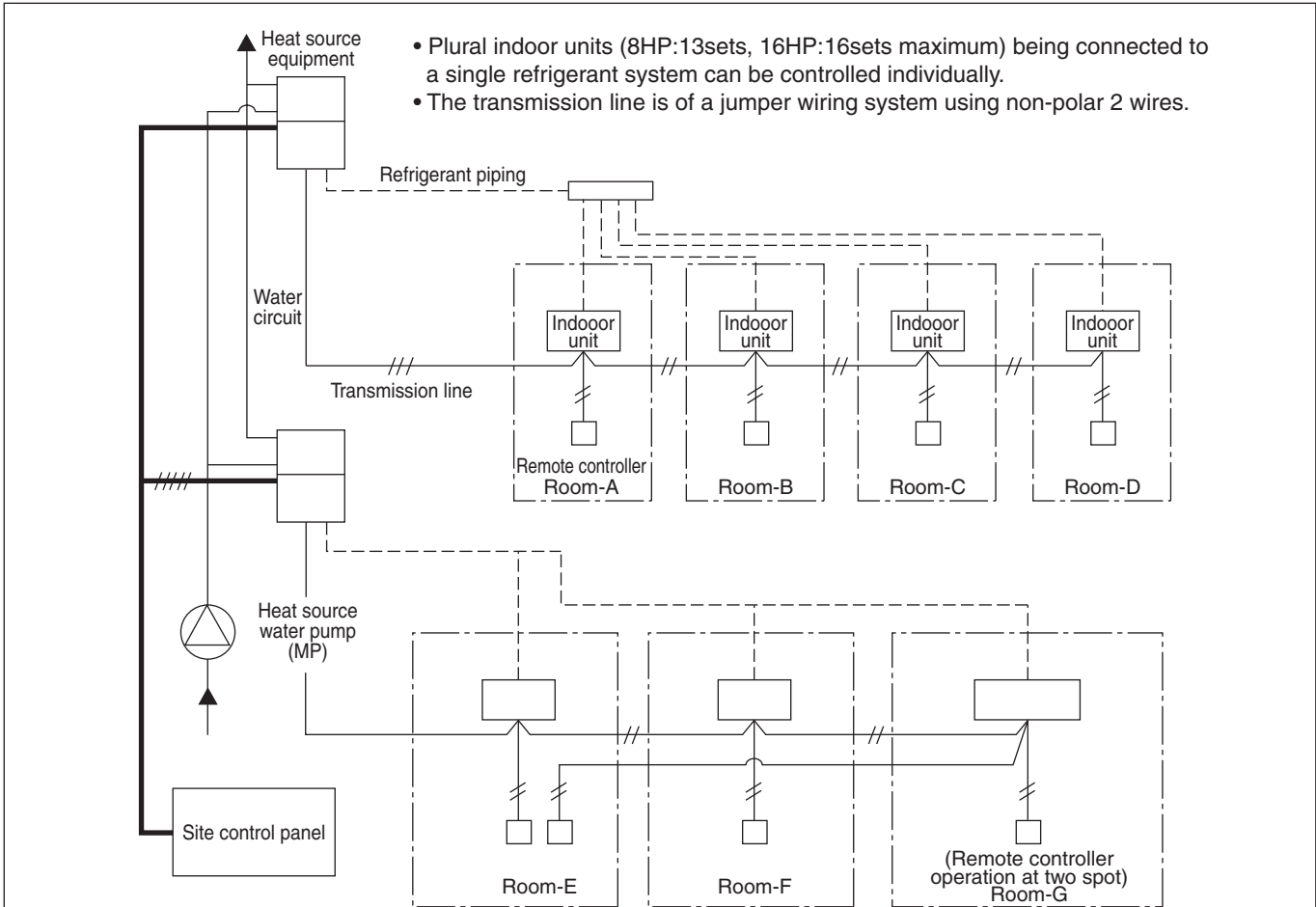

**Wiring diagram**

This circuit uses the "Terminal block for pump interlock (TB8)" inside the electrical parts box of the heat source equipment. This circuit is for interlocking of the heat source equipment operation and the heat source water pump.

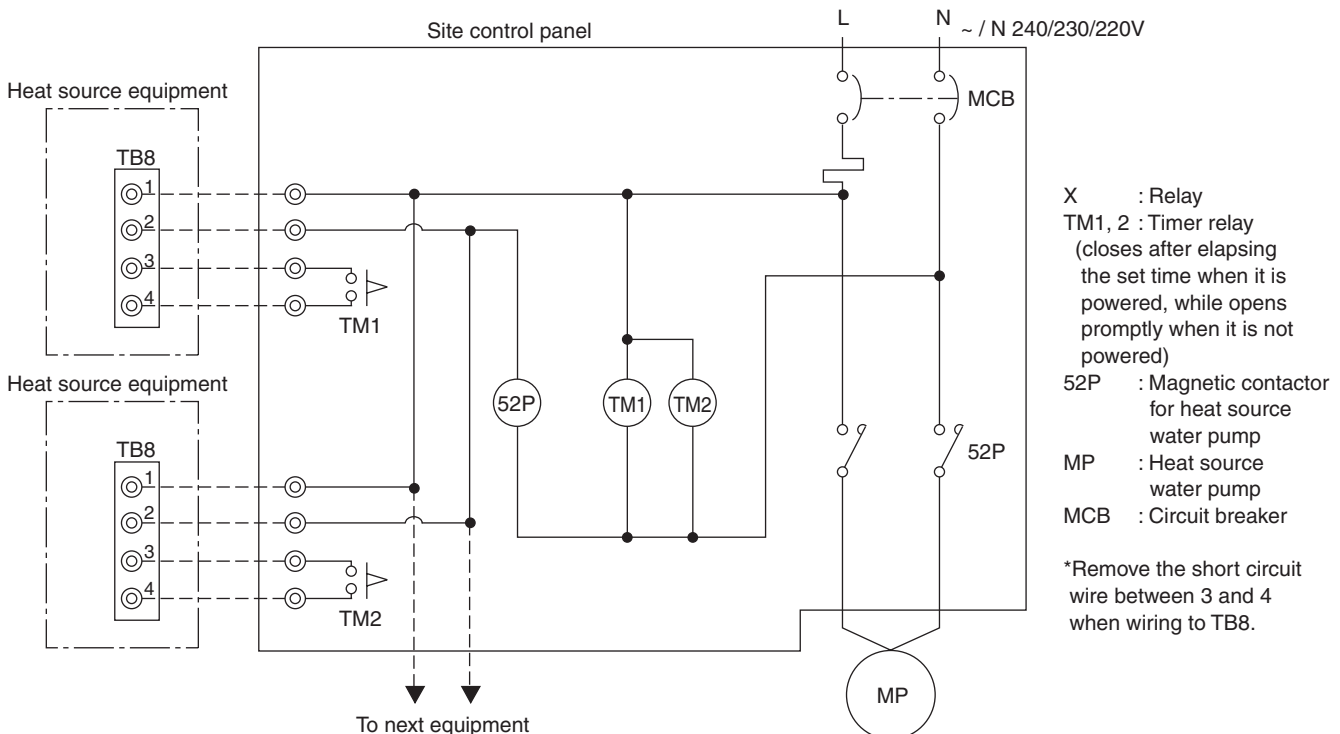

**Operation ON signal**

Terminal No.	TB8-1, 2
Output	Relay contacts output      Rated voltage : L1 - N : 220 ~ 240V Rated load : 1A
Operation	<ul style="list-style-type: none"> <li>• When Dip switch 2-7 is OFF The relay closes during compressor operation.</li> <li>• When DIP switch 2-7 is ON. The relay closes during reception of cooling or the heating operation signal from the controller. (Note : It is output even if the thermostat is OFF (when the compressor is stopped).)</li> </ul>

**Pump Interlock**

Terminal No.	TB8-3, 4
Input	Level signal
Operation	If the circuit between TB8-3 and TB8-4 is open, compressor operation is prohibited.

Y

R2

WY

WR2

S

OP

7-2.WATER PIPING WORK

Although the water piping for the CITY MULTI WY system does not differ from that for ordinary air conditioning systems, pay special attention to the items below in conducting the piping work.

1) Items to be observed on installation work

- In order to equalize piping resistance for each unit, adapt the reverse return system.
- Mount a joint and a valve onto the water outlet/inlet of the unit to allow for maintenance, inspection and replacement work. Be sure to mount a strainer at the water inlet piping of the unit. (The strainer is required at the circulation water inlet to protect the heat source unit.)
- \* The installation example of the heat source unit is shown right.
- Be sure to provide an air relief opening on the water piping properly, and purge air after feeding water to the piping system.
- Condensate will generate at the low temperature part inside the heat source equipment. Connect drain piping to the drain piping connection located at the bottom of the heat source equipment to discharge it outside the equipment.
- At the center of the header of the heat exchanger water inlet inside the unit, a plug for water discharge is being provided.  
Use it for maintenance work or the like.
- Mount a backflow prevention valve and a flexible joint for vibration control onto the pump.
- Provide a sleeve to the penetrating parts of the wall to prevent the piping.
- Fasten the piping with metal fitting, arrange the piping not to expose to cutting or bending force, and pay sufficient care for possible vibration.
- Be careful not to erroneously judge the position of the inlet and outlet of water.  
(Lower position : Inlet, Upper position : Outlet)

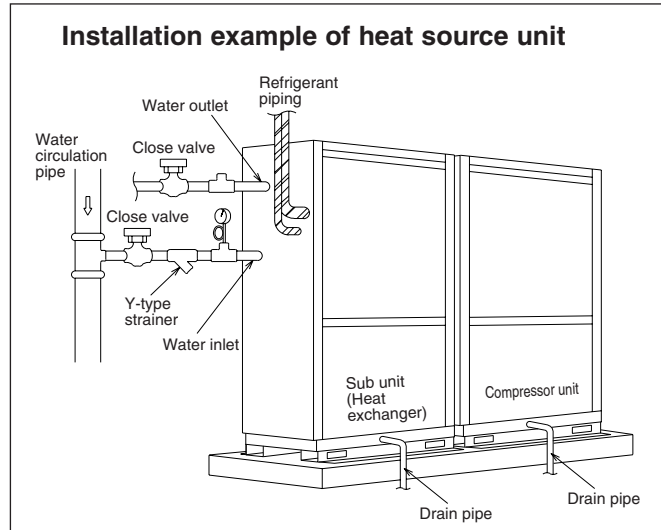

3) Water treatment and water quality control

For the circulation water cooling tower of the CITY MULTI WY system, employment of the closed type is recommended to keep water quality. However, in the case that an open type cooling tower is employed or the circulating water quality is inferior, scale will adhere onto the water heat exchanger leading to the decreased heat exchange capacity or the corrosion of the heat exchanger. Be sufficiently careful for water quality control and water treatment at the installation of the circulation water system.

- Removal of impurities inside piping  
Be careful not to allow impurities such as welding fragment, remaining sealing material and rust from mixing into the piping during installation work.
- Water treatment  
The water quality standards have been established by the industry (Japan Refrigeration, Air Conditioning Industry Association, in case of Japan) for water treatment to be applied.

2) Thermal insulation work

Thermal insulation or antisweating work is not required for the piping inside buildings in the case of the CITY MULTI WY system if the operating temperature range of circulation water stays within the temperature near the normal (summer : 30°C, winter : 20°C).

In case of the conditions below, however, thermal insulation is required.

- Use of well water for heat source water
- Outdoor piping portions
- Indoor piping portions where freezing may be caused in winter
- A place where vapor condensation may be generated on piping due to an increase in dry bulb temperature inside the ceiling caused by the entry of fresh outdoor air
- Drain piping portions

Items	Lower mid-range temperature water system		Tendency	
	Recirculating water [20<T<60°C]	Make-up water	Corrosive	Scale-forming
pH (25°C)	7.0 ~ 8.0	7.0 ~ 8.0	○	○
Electric conductivity (mS/m) (25°C) (μs/cm) (25°C)	30 or less [300 or less]	30 or less [300 or less]	○	○
Chloride ion (mg Cl/l)	50 or less	50 or less	○	
Sulfate ion (mg SO <sub>4</sub> <sup>2-</sup> /l)	50 or less	50 or less	○	
Acid consumption (pH4.8) (mg CaCO <sub>3</sub> /l)	50 or less	50 or less		○
Total hardness (mg CaCO <sub>3</sub> /l)	70 or less	70 or less		○
Calcium hardness (mg CaCO <sub>3</sub> /l)	50 or less	50 or less		○
Ionic silica (mg SiO <sub>2</sub> /l)	30 or less	30 or less		○
Iron (mg Fe/l)	1.0 or less	0.3 or less	○	○
Copper (mg Cu/l)	1.0 or less	0.1 or less	○	
Sulfide ion (mg S <sup>2-</sup> /l)	not to be detected	not to be detected	○	
Ammonium ion (mg NH <sub>4</sub> <sup>+</sup> /l)	0.3 or less	0.1 or less	○	
Residual chlorine (mg Cl/l)	0.25 or less	0.3 or less	○	
Free carbon dioxide (mg CO <sub>2</sub> /l)	0.4 or less	4.0 or less	○	
Ryzner stability index	-	-	○	○

Reference : Guideline of Water Quality for Refrigeration and Air Conditioning Equipment. (JRA GL02E-1994)



In order to keep the water quality within such standards, you are kindly requested to conduct bleeding-off by overflow and periodical water quality tests, and use inhibitors to suppress condensation or corrosion. Since piping may be corroded by some kinds of inhibitor, consult an appropriate water treatment expert for proper water treatment.

### (4) Pump interlock

Operating the heat source unit without circulation water inside the water piping can cause a trouble. Be sure to provide interlocking for the unit operation and water circuit. Since the terminal block is being provided inside the unit, use it as required.

Y

R2

WY

WR2

S

OP

Y

R2

**WY**

WR2

S

OP

# CITY MULTI™ HEAT SOURCE UNITS

# WR2 SERIES

WR2 SERIES

1. SPECIFICATIONS
2. CAPACITY TABLES
  - 2.1 Correction by temperature
  - 2.2 Correction by total indoor
  - 2.3 Correction by refrigerant piping length
  - 2.4 Temp. range of running
3. SOUND LEVELS
4. EXTERNAL DIMENSIONS
5. ELECTRICAL WIRING DIAGRAMS
6. REFRIGERANT CIRCUIT DIAGRAMS AND THERMAL SENSORS
7. SYSTEM DESIGN GUIDE

- WR2-2
- WR2-5
- WR2-5
- WR2-9
- WR2-10
- WR2-12
- WR2-13
- WR2-14
- WR2-16
- WR2-17
- WR2-19

- Y
- R2
- WY
- WR2
- S
- OP

Heat recovery: PQRV-P-Y(S)GM-A

	200	250	300	350	400	450	500	550	600	650	700	750	800	850	900	950	1000	1050	1100	1150	1200	1250
	8HP	10HP	12HP	14HP	16HP	18HP	20HP	22HP	24HP	26HP	28HP	30HP	32HP	34HP	36HP	38HP	40HP	42HP	44HP	46HP	48HP	50HP
WR2 Heat recovery	●	●			●		●															

# 1. SPECIFICATIONS

R410A Data G2

Model			PQRY-P200YGM-A	PQRY-P250YGM-A
Power source			3-phase 4-wire 380-400-415V 50 / 60Hz	
Cooling capacity (Nominal)	*1	kW	22.4	28.0
	*1	kcal / h	19,300	24,100
	*1	Btu / h	76,400	95,500
		Power input kW	4.79	5.95
		Current input A	8.0 - 7.6 - 7.4	10.0 - 9.5 - 9.1
COP (kW / kW)			4.68	4.71
Temp. range of cooling	Indoor		15 ~ 24°CWB (59 ~ 75°FWB)	
	Circulating water		10 ~ 45°C (50 ~ 113°F)	
Heating capacity (Nominal)	*2	kW	25.0	31.5
	*2	kcal / h	21,500	27,100
	*2	Btu / h	85,300	107,500
		Power input kW	4.69	5.8
		Current input A	7.9 - 7.5 - 7.2	9.7 - 9.3 - 8.9
COP (kW / kW)			5.33	5.43
Temp. range of heating	Indoor		15 ~ 27°CDB (59 ~ 81°FDB)	
	Circulating water		10 ~ 45°C (50 ~ 113°F)	
			15 ~ 45°C (59 ~ 113°F) (when total indoor unit capacity exceeds 130% of the PQRY-P-YGM)	
Indoor unit connectable	Total capacity		50 ~ 150% of Heat source unit capacity	
	Model / Quantity		P20 ~ P250 / 1 ~ 15	P20 ~ P250 / 1 ~ 19
Noise level (measured in anechoic room)		dB <A>	46 / 46	47 / 47
Diameter of refrigerant pipe	Liquid (High press.)		ø15.88 (ø5/8") Brazed	ø19.05 (ø3/4") Brazed
	Gas (Low press.)		ø19.05 (ø3/4") Brazed	ø22.2 (ø7/8") Brazed

External finish			Acrylic painted steel plate	
External dimension H x W x D	mm		1,800 x 990 x 550	1,800 x 990 x 550
	in.		70-7/8" x 39" x 21-5/8"	70-7/8" x 39" x 21-5/8"
Net weight		kg (lb)	263 (580)	266 (587)
Heat exchanger			Pipe-in-pipe coil	
Water volume in coil	l		9.5	10.5
	MPa		1.0	1.0
Compressor	Type		Inverter scroll hermetic comp.	
	Manufacturer		AC&R Works, MITSUBISHI ELECTRIC CORPORATION	
	Starting method		Inverter	
	Motor output kW		5	6
	Case heater kW		0.045 x 1 (240V)	0.045 x 1 (240V)
	Lubricant		MEL32	
Circulating water	Water flow rate	m <sup>3</sup> / h	4.56	5.76
		L / min	76	96
		cfm	2.7	3.4
	Pressure drop	kPa	16.5	19.5
	Operating volume range	m <sup>3</sup> / h	3.9 - 6.0	4.5 - 7.2
HIC circuit (HIC: Heat Inter-Changer)			-	
Protection	High pressure protection		High pressure sensor, High pressure switch 4.15 MPa (601 psi)	
	Inverter circuit		Over-current protection, Thermal protection	
	Compressor		Over-current protection, Over-heat protection	
Refrigerant	Type x Original charge		R410A x 7.0 kg (16 lb)	R410A x 9.5 kg (21 lb)
	Control		LEV + BC	
Drawing	External		OU-W663144	
	Wiring		OU-W274643	
	Refrigerant circle		RC_WYNA1-1132-13	
Standard attachment	Document		Installation Manual	
	Accessory		Details refer to External Drw. YGM-CM04EU4-C_P20(W663144)	
Optional parts			Joint : CMY-Y102S-G, CMY-R160-J BC controller: CMB-P104, 105, 106, 108, 1010, 1013, 1016-G Main BC controller: CMB-P108, 1010, 1013, 1016-GA Sub BC controller: CMP-P104, 108V-GB	
Remark			a. The ambient temperature of the Heat Source Unit PQRY-P-YGM-A needs to be kept below 40°CDB. b. The ambient relative humidity of the Heat Source Unit PQRY-P-YGM-A needs to be kept below 80%. c. The Heat Source Unit PQRY-P-YGM-A should not be installed at outdoor. d. Details on foundation work, duct work, insulation work, electrical wiring, power source switch, and other items shall be referred to the Installation Manual.	

Note :		*1 Nominal cooling conditions	*2 Nominal heating conditions	Unit converter
Indoor :	27°CDB/19°CWB (81°FDB/66°FWB)	20°CDB (68°FDB)	20°C (68°F)	kcal/h = kW x 860
Water temperature:	30°C (86°F)	20°C (68°F)	7.5 m (24-9/16 ft)	Btu/h = kW x 3,412
Pipe length :	7.5 m (24-9/16 ft)	7.5 m (24-9/16 ft)	0 m (0 ft)	cfm = m <sup>3</sup> /min x 35.31
Level difference :	0 m (0 ft)	0 m (0 ft)		lb = kg / 0.4536
* Nominal conditions *1, *2 are subject to JIS B8615-1.				*Above specification data is subject to rounding variation.
* Due to continuing improvement, above specifications may be subject to change without notice.				

Ref. : Spec\_wr2\_p200\_250ygm

# 1. SPECIFICATIONS

Model (Set name)		PQRY-P400YSGM-A	
Power source		3-phase 4-wire 380-400-415V 50 / 60Hz	
Cooling capacity (Nominal)	*:1 kW	45.0	
	*:1 kcal / h	38,700	
	*:1 Btu / h	153,500	
	Power input kW	11.35	
	Current input A	19.1 - 18.2 - 17.5	
COP (kW / kW)		3.96	
Temp. range of cooling	Indoor	15 ~ 24°CWB (59 ~ 75°FWB)	
	Circulating water	10 ~ 45°C (50 ~ 113°F)	
Heating capacity (Nominal)	*:2 kW	50.0	
	*:2 kcal / h	43,000	
	*:2 Btu / h	170,600	
	Power input kW	11.01	
	Current input A	18.5 - 17.6 - 17.0	
COP (kW / kW)		4.54	
Temp. range of heating	Indoor	15 ~ 27°CDB (59 ~ 81°FDB)	
	Circulating water	10 ~ 45°C (50 ~ 113°F)	
		15 ~ 45°C (59 ~ 113°F) (when total indoor unit capacity exceeds 130% of the PQRY-P-YGM)	
Indoor unit connectable	Total capacity	50 ~ 150% of Heat source unit capacity	
	Model / Quantity	P20 ~ P250 / 1 ~ 24	
Noise level (measured in anechoic room)	dB <A>	50 / 50	
Diameter of refrigerant pipe	Liquid (High press.)	mm (in.)	ø22.2 (ø7/8") Brazed
	Gas (Low press.)	mm (in.)	ø28.58 (ø1-1/8") Brazed

The Set model is a combination of Compressor unit and Sub unit as follows.

Model (Compressor unit and Sub unit)		PQY-P01YGM-A (Compressor unit)		PQRY-P400YGM-A (Sub unit)	
External finish		Acrylic painted steel plate			
External dimension H x W x D	mm	1,800 x 990 x 550		1,800 x 990 x 550	
	in.	70-7/8" x 39" x 21-5/8"		70-7/8" x 39" x 21-5/8"	
Net weight	kg (lb)	208 (459)		232 (512)	
Heat exchanger			-		
	Water volume in coil	l	-		Pipe-in-pipe coil
	Water pressure Max.	MPa	-		17.5
Compressor	Type		Inverter scroll hermetic comp.		
	Manufacturer	kW	AC&R Works, MITSUBISHI ELECTRIC CORPORATION		
	Starting method	kW	Inverter		
	Motor output		9.7		
	Case heater		0.045 x 1 (240V)		
	Lubricant		MEL32		
Circulating water	Water flow rate	m <sup>3</sup> / h	9.12		
		L / min	152		
		cfm	5.4		
	Pressure drop	kPa	16.5		
Operating volume range	m <sup>3</sup> / h	7.8 - 12.0			
HIC circuit (HIC: Heat Inter-Changer)		-		Pipe-in-pipe structure	
Protection	High pressure protection		High pressure sensor, High pressure switch 4.15 MPa (601 psi)		
	Inverter circuit		Over-current protection, Thermal protection		
	Compressor		Over-current protection, Over-heat protection		
Refrigerant	Type x Original charge		R410A x 7.0 kg (16 lb)		R410A x 9.5 kg (21 lb)
	Control		LEV and HIC circuit		
Refrigerant piping diameter (between comp. & sub)		ø9.52 (ø3/8") Flare / ø19.05 (ø3/4") Flare / ø28.58 (ø1-1/8") Brazed			
Drawing	External		OU-W663146		
	Wiring		OU-W274643		
	Refrigerant circle		RC_WYNA1-1132-14		
Standard attachment	Document		Installation Manual		
	Accessory		Details refer to External Drw. YSGM-CM04EU4-C_P21(W663146)		
Optional parts		Joint : CMY-Y102S-G, CMY-R160-J Main BC controller: CMB-P108, 1010, 1013, 1016-GA Sub BC controller: CMP-P104, 108V-GB			
Remark		a. The ambient temperature of the Heat Source Unit PQRY-P-YSGM-A needs to be kept below 40°CDB. b. The ambient relative humidity of the Heat Source Unit PQRY-P-YSGM-A needs to be kept below 80%. c. The Heat Source Unit PQRY-P-YSGM-A should not be installed at outdoor. d. Details on foundation work, duct work, insulation work, electrical wiring, power source switch, and other items shall be referred to the Installation Manual.			

<b>Note :</b>	*:1 Nominal cooling conditions		*:2 Nominal heating conditions		<b>Unit converter</b> kcal/h = kW x 860 Btu/h = kW x 3,412 cfm = m <sup>3</sup> /min x 35.31 lb = kg / 0.4536 *Above specification data is subject to rounding variation.
	Indoor :	27°CDB/19°CWB (81°FDB/66°FWB)	20°CDB (68°FDB)		
	Water temperature:	30°C (86°F)	20°C (68°F)		
	Pipe length :	7.5 m (24-9/16 ft)	7.5 m (24-9/16 ft)		
	Level difference :	0 m (0 ft)	0 m (0 ft)		
* Nominal conditions *:1, *:2 are subject to JIS B8615-1. * Due to continuing improvement, above specifications may be subject to change without notice.					

# 1. SPECIFICATIONS

R410A Data G2

Model (Set name)			PQRY-P500YSGM-A			
Power source			3-phase 4-wire 380-400-415V 50 / 60Hz			
Cooling capacity (Nominal)	*1	kW	56.0			
	*1	kcal / h	48,200			
	*1	Btu / h	191,100			
	Power input		kW	15.06		
	Current input		A	25.4 - 24.2 - 23.3		
COP (kW / kW)			3.72			
Temp. range of cooling	Indoor		15 ~ 24°CWB (59 ~ 75°FWB)			
	Circulating water		10 ~ 45°C (50 ~ 113°F)			
Heating capacity (Nominal )	*2	kW	63.0			
	*2	kcal / h	54,200			
	*2	Btu / h	215,000			
	Power input		kW	13.60		
	Current input		A	22.9 - 21.8 - 21.0		
COP (kW / kW)			4.63			
Temp. range of heating	Indoor		15 ~ 27°CDB (59 ~ 81°FDB)			
	Circulating water		10 ~ 45°C (50 ~ 113°F) 15 ~ 45°C (59 ~ 113°F) (when total indoor unit capacity exceeds 130% of the PQRY-P-YGM)			
Indoor unit connectable	Total capacity		50 ~ 150% of Heat source unit capacity			
	Model / Quantity		P20 ~ P250 / 1 ~ 24			
Noise level (measured in anechoic room)		dB <A>		53 / 53		
Diameter of refrigerant pipe	Liquid (High press.)		mm (in.)		ø22.2 (ø7/8") Brazed	
	Gas (Low press.)		mm (in.)		ø28.58 (ø1-1/8") Brazed	

The Set model is a combination of Compressor unit and Sub unit as follows.

Model (Compressor unit and Sub unit)			PQY-P01YGM-A (Compressor unit)		PQRY-P500YGM-A (Sub unit)	
External finish			Acrylic painted steel plate			
External dimension H x W x D	mm		1,800 x 990 x 550		1,800 x 990 x 550	
	in.		70-7/8" x 39" x 21-5/8"		70-7/8" x 39" x 21-5/8"	
Net weight			kg (lb)		208 (459) / 236 (521)	
Heat exchanger			-		Pipe-in-pipe coil	
	Water volume in coil		l		-	
	Water pressure Max.		MPa		-	
Compressor	Type		Inverter scroll hermetic comp.		-	
	Manufacturer		kW		AC&R Works, MITSUBISHI ELECTRIC CORPORATION	
	Starting method		kW		Inverter	
	Motor output				9.7	
	Case heater				0.045 x 1 (240V)	
	Lubricant				MEL32	
Circulating water	Water flow rate	m³ / h		11.52		
		L / min		192		
		cfm		6.8		
	Pressure drop		kPa		19.5	
Operating volume range		m³ / h		9.0 - 14.4		
HIC circuit (HIC: Heat Inter-Changer)			-		Pipe-in-pipe structure	
Protection	High pressure protection		High pressure sensor, High pressure switch 4.15 MPa (601 psi)			
	Inverter circuit		Over-current protection, Thermal protection			
	Compressor		Over-current protection, Over-heat protection			
Refrigerant	Type x Original charge		R410A x 7.0 kg (16 lb)		R410A x 9.5 kg (21 lb)	
	Control		LEV and HIC circuit			
Refrigerant piping diameter (between comp. & sub)			ø9.52 (ø3/8") Flare / ø19.05 (ø3/4") Flare / ø28.58 (ø1-1/8") Brazed			
Drawing	External		OU-W663146			
	Wiring		OU-W274643			
	Refrigerant circle		RC_WYNA1-1132-14			
Standard attachment	Document		Installation Manual			
	Accessory		Details refer to External Drw. YSGM-CM04EU4-C_P21(W663146)			
Optional parts			Joint : CMY-Y102S-G, CMY-R160-J Main BC controller: CMB-P108, 1010, 1013, 1016-GA Sub BC controller: CMP-P104, 108V-GB			
Remark			<p>a. The ambient temperature of the Heat Source Unit PQRY-P-YSGM-A needs to be kept below 40°CDB.</p> <p>b. The ambient relative humidity of the Heat Source Unit PQRY-P-YSGM-A needs to be kept below 80%.</p> <p>c. The Heat Source Unit PQRY-P-YSGM-A should not be installed at outdoor.</p> <p>d. Details on foundation work, duct work, insulation work, electrical wiring, power source switch, and other items shall be referred to the Installation Manual.</p>			

Note :			Unit converter		
*1 Nominal cooling conditions		*2 Nominal heating conditions			
Indoor : 27°CDB/19°CWB (81°FDB/66°FWB)		20°CDB (68°FDB)		kcal/h = kW x 860	
Water temperature: 30°C (86°F)		20°C (68°F)		Btu/h = kW x 3,412	
Pipe length : 7.5 m (24-9/16 ft)		7.5 m (24-9/16 ft)		cfm = m³/min x 35.31	
Level difference : 0 m (0 ft)		0 m (0 ft)		lb = kg / 0.4536	
* Nominal conditions *1, *2 are subject to JIS B8615-1.				* Above specification data is subject to rounding variation.	
* Due to continuing improvement, above specifications may be subject to change without notice.					

Ref. : Spec\_wr2\_p500ysgm

## 2-1. Correction by temperature

CITY MULTI™ could have varied capacity at different designing temperature. Using the nominal cooling/heating capacity value and the ratio below, the capacity can be observed at various temperature.

PQRY-		P200YGM
Nominal Cooling Capacity	kW	22.4
	kcal/h	19,300
	Btu/h	76,400
Input	kW	4.79

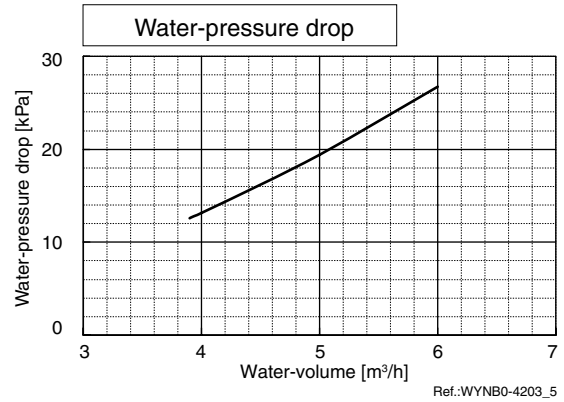
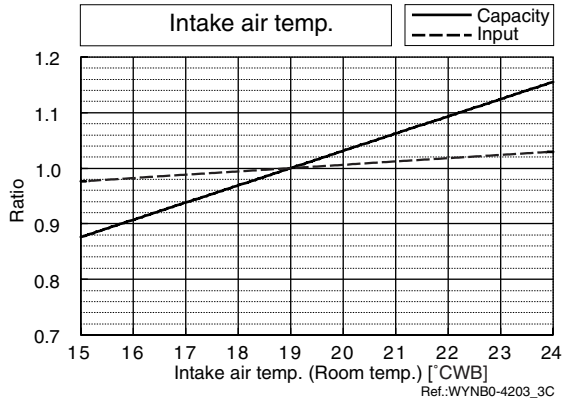
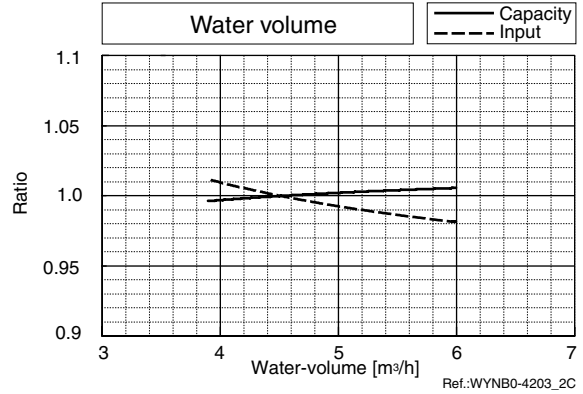
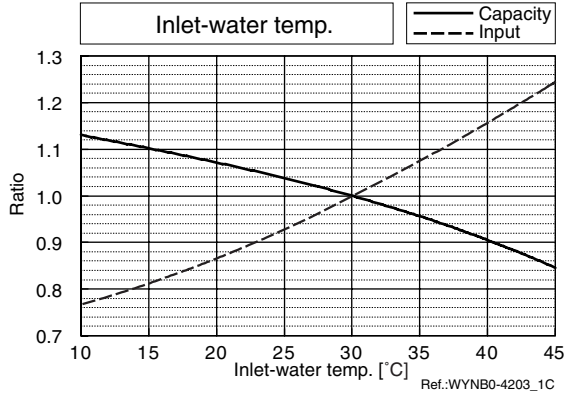

PQRY-		P200YGM
Nominal Heating Capacity	kW	25.0
	kcal/h	21,500
	Btu/h	85,300
Input	kW	4.69

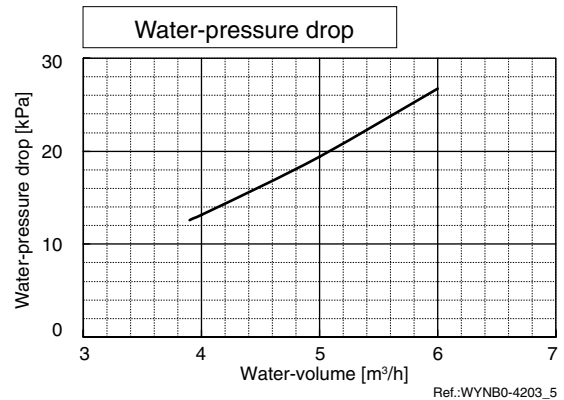
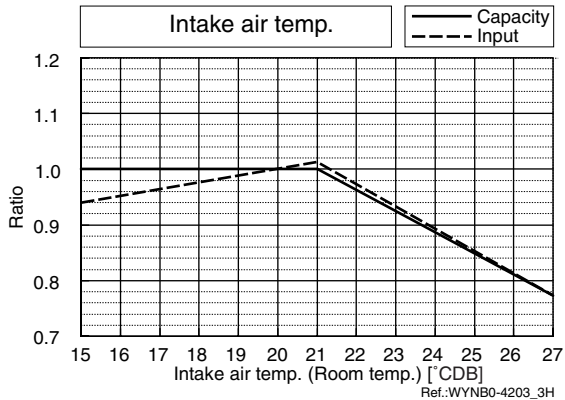
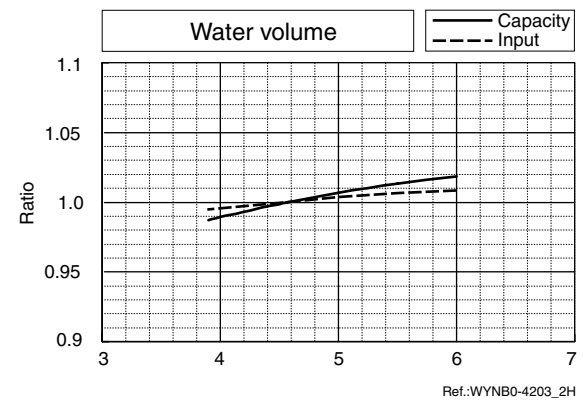
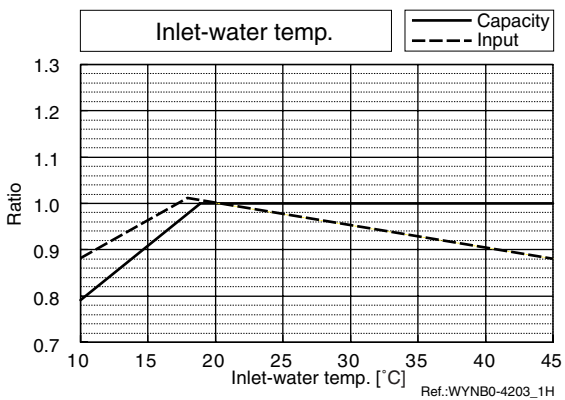

## 2-1. Correction by temperature

CITY MULTI™ could have varied capacity at different designing temperature. Using the nominal cooling/heating capacity value and the ratio below, the capacity can be observed at various temperature.

PQRY-		P250YGM
Nominal Cooling Capacity	kW	28.0
	kcal/h	24,100
	Btu/h	95,500
Input	kW	5.95

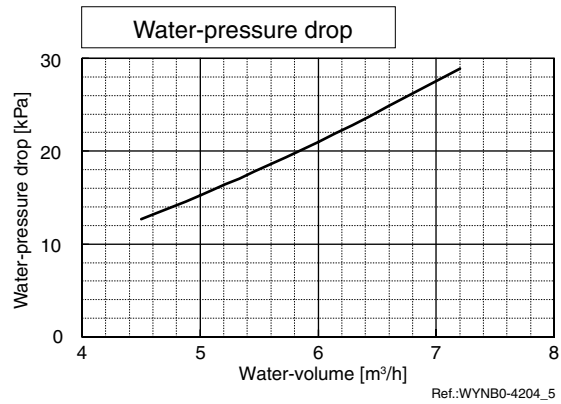
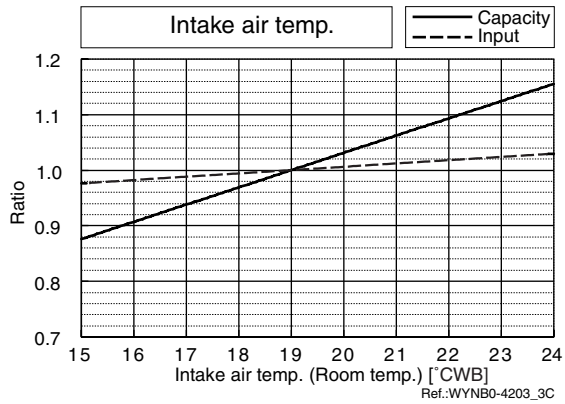
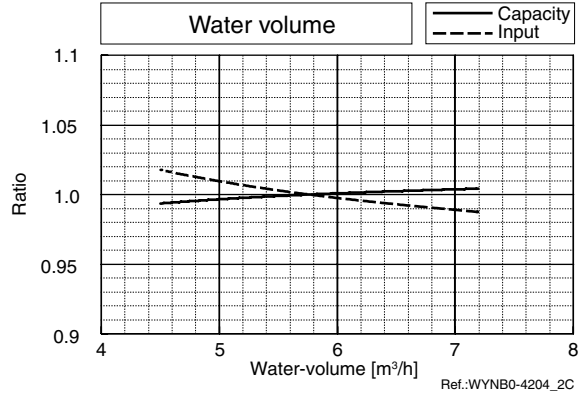
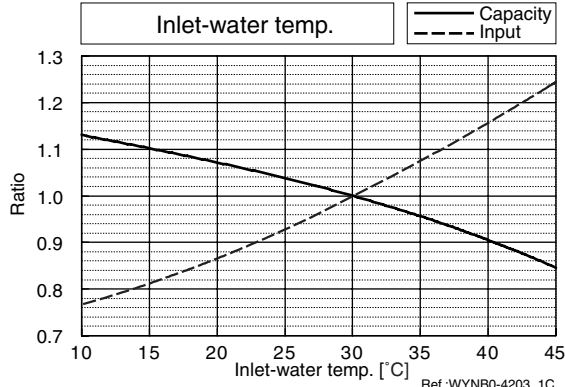

PQRY-		P250YGM
Nominal Heating Capacity	kW	31.5
	kcal/h	27,100
	Btu/h	107,500
Input	kW	5.8

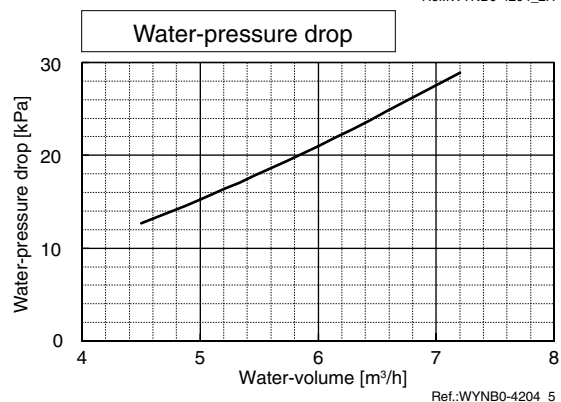
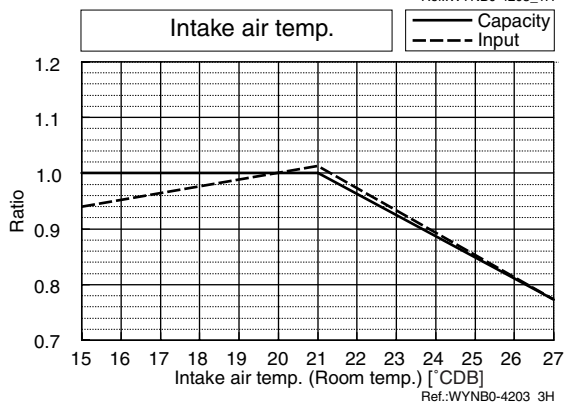
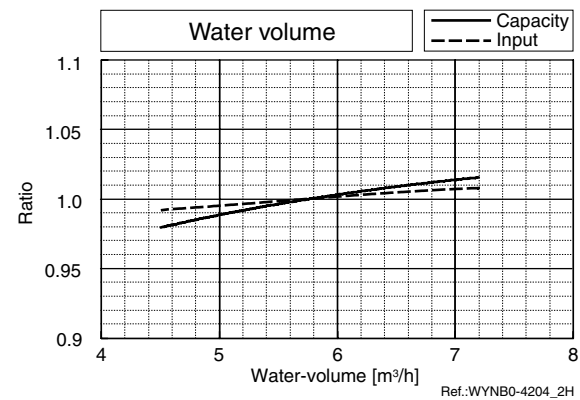
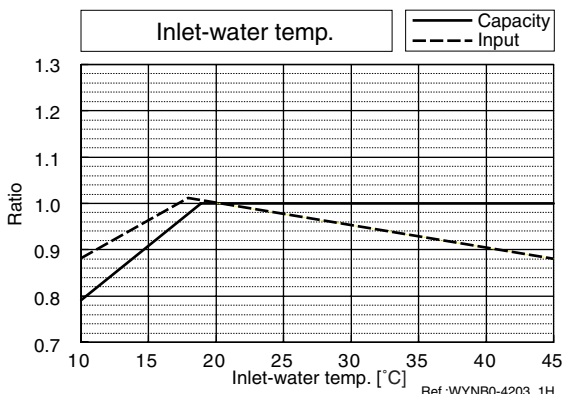



## 2. CAPACITY TABLES

### 2-1. Correction by temperature

CITY MULTI™ could have varied capacity at different designing temperature. Using the nominal cooling/heating capacity value and the ratio below, the capacity can be observed at various temperature.

PQRY-		P400YSGM
Nominal Cooling Capacity	kW	45.0
	kcal/h	38,700
	Btu/h	153,500
Input	kW	11.35

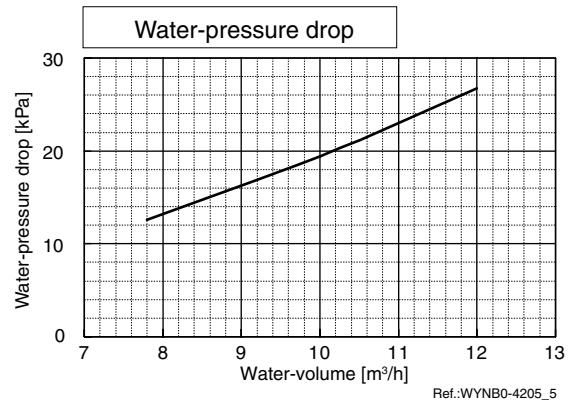
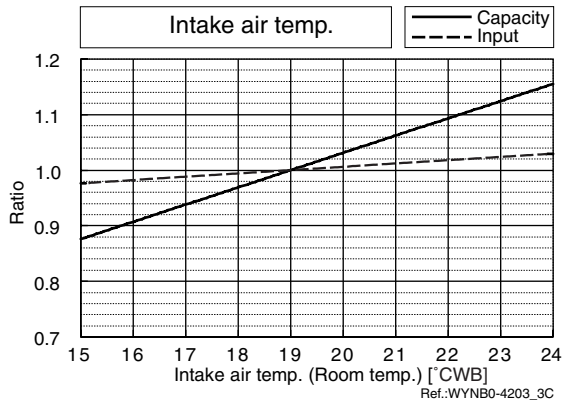
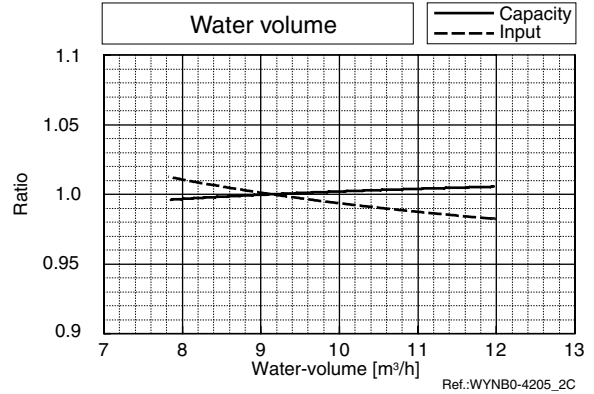
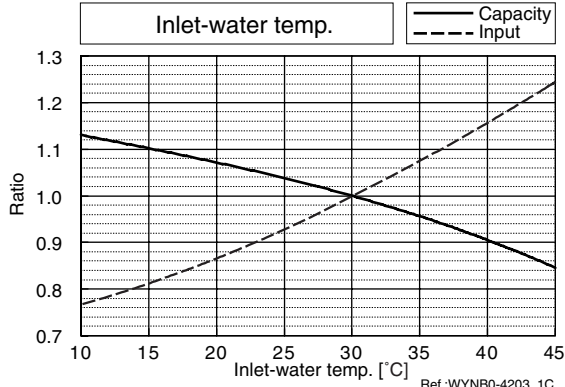

PQRY-		P400YSGM
Nominal Heating Capacity	kW	50.0
	kcal/h	43,000
	Btu/h	170,600
Input	kW	11.01

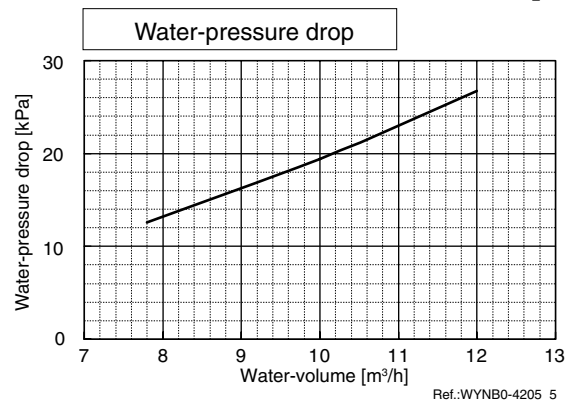
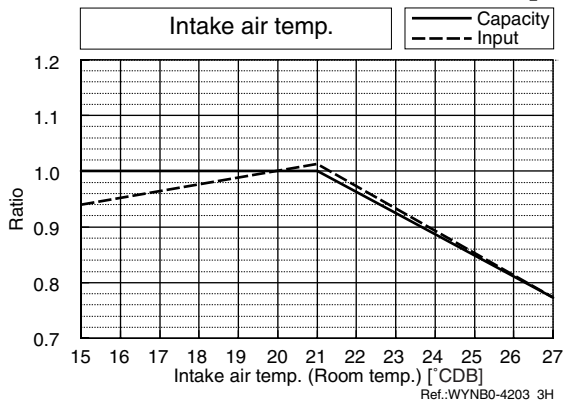
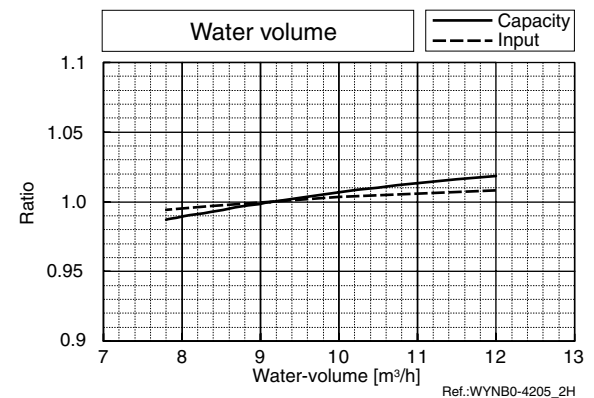
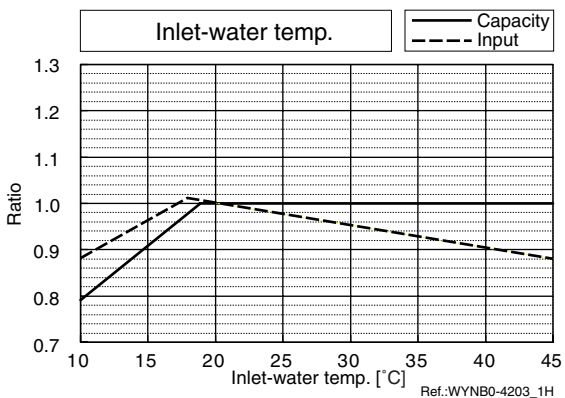

2-1. Correction by temperature

CITY MULTI™ could have varied capacity at different designing temperature. Using the nominal cooling/heating capacity value and the ratio below, the capacity can be observed at various temperature.

PQRY-		P500YSGM
Nominal Cooling Capacity	kW	56.0
	kcal/h	48,200
	Btu/h	191,100
Input	kW	15.06

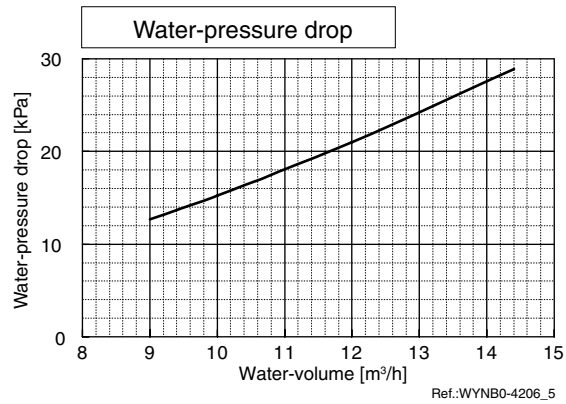
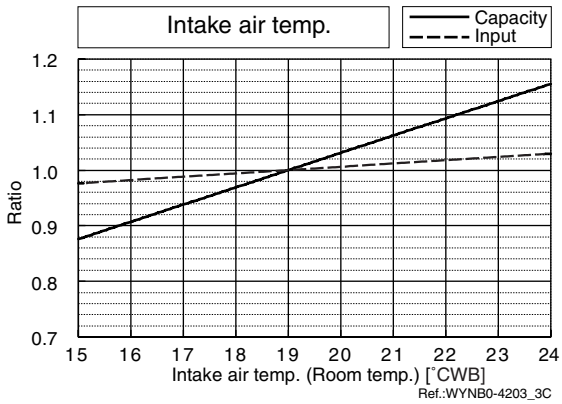
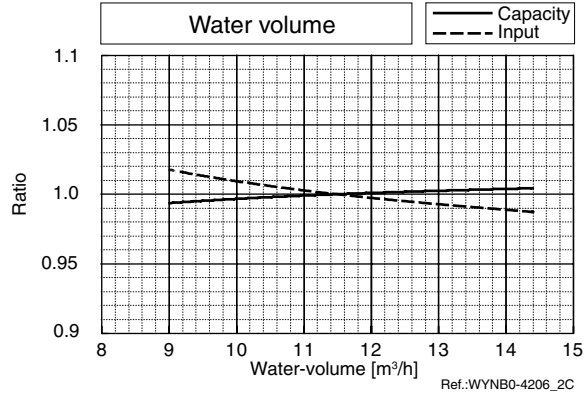
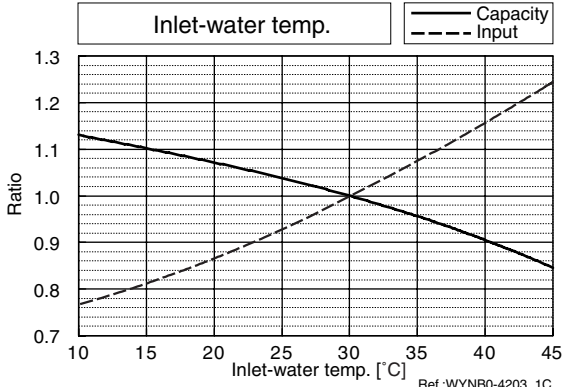

PQRY-		P500YSGM
Nominal Heating Capacity	kW	63.0
	kcal/h	54,200
	Btu/h	215,000
Input	kW	13.60

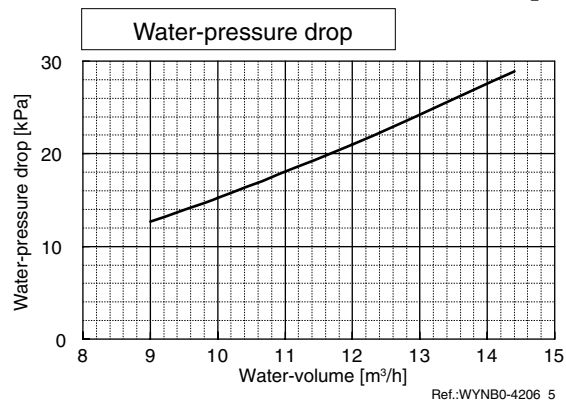
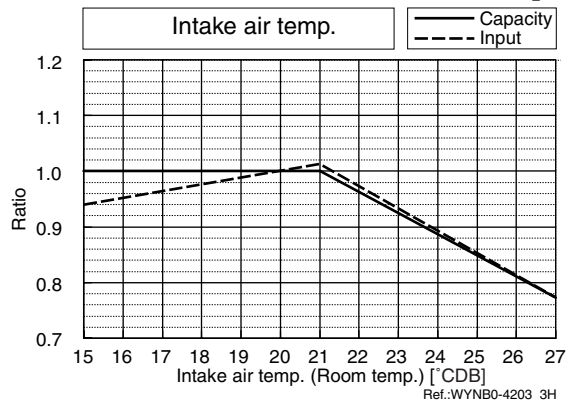
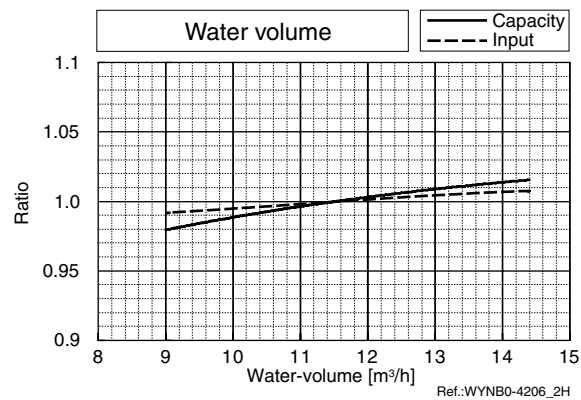
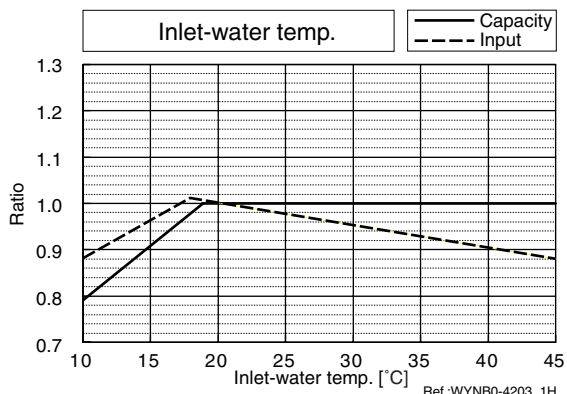

## 2. CAPACITY TABLES

### 2-2. Correction by total indoor

CITY MULTI™ system has different capacity and input at different total capacity of indoor unit connected. Using following tables, the maximum capacity can be observed so as to ensure the system having enough capacity.

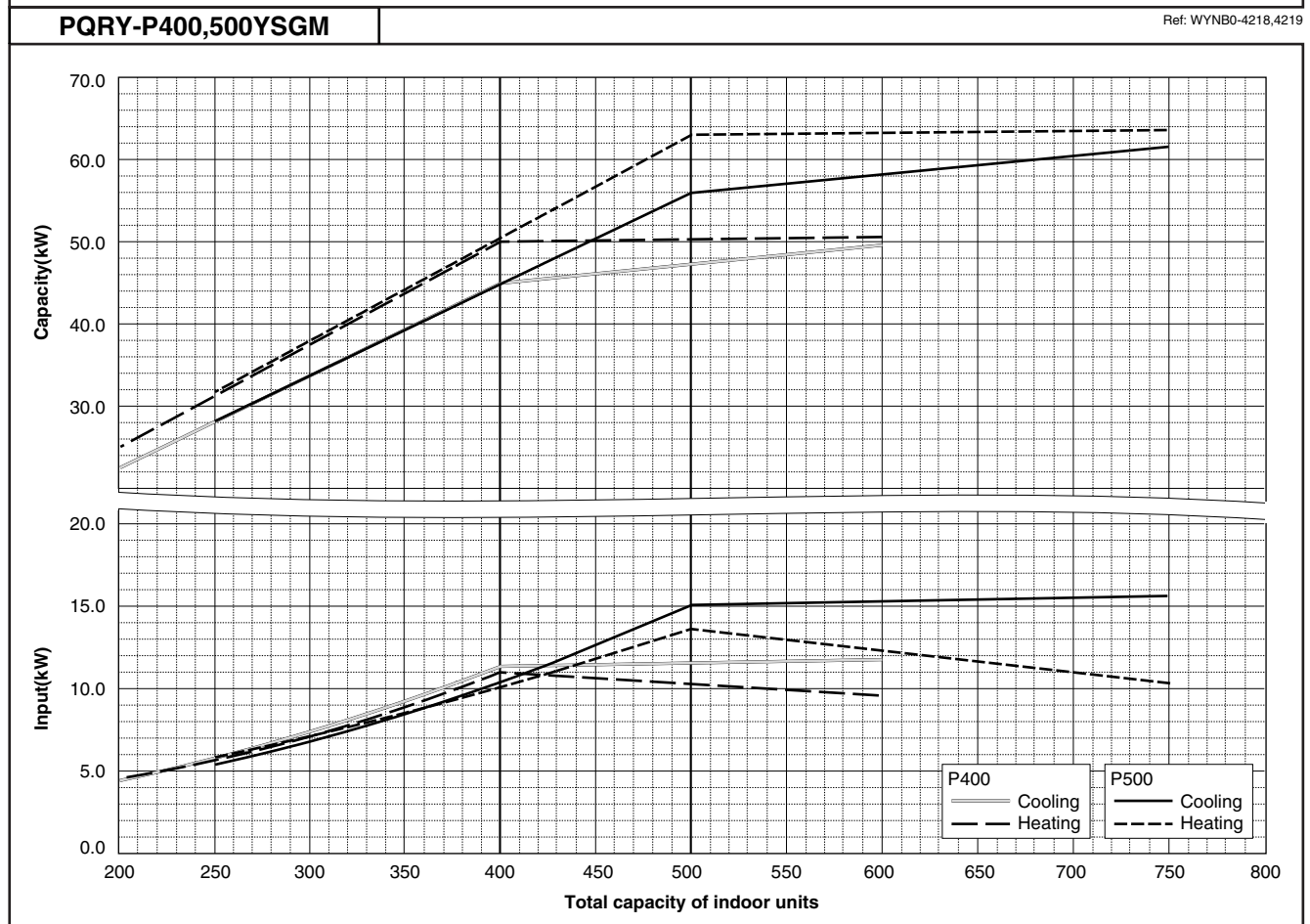
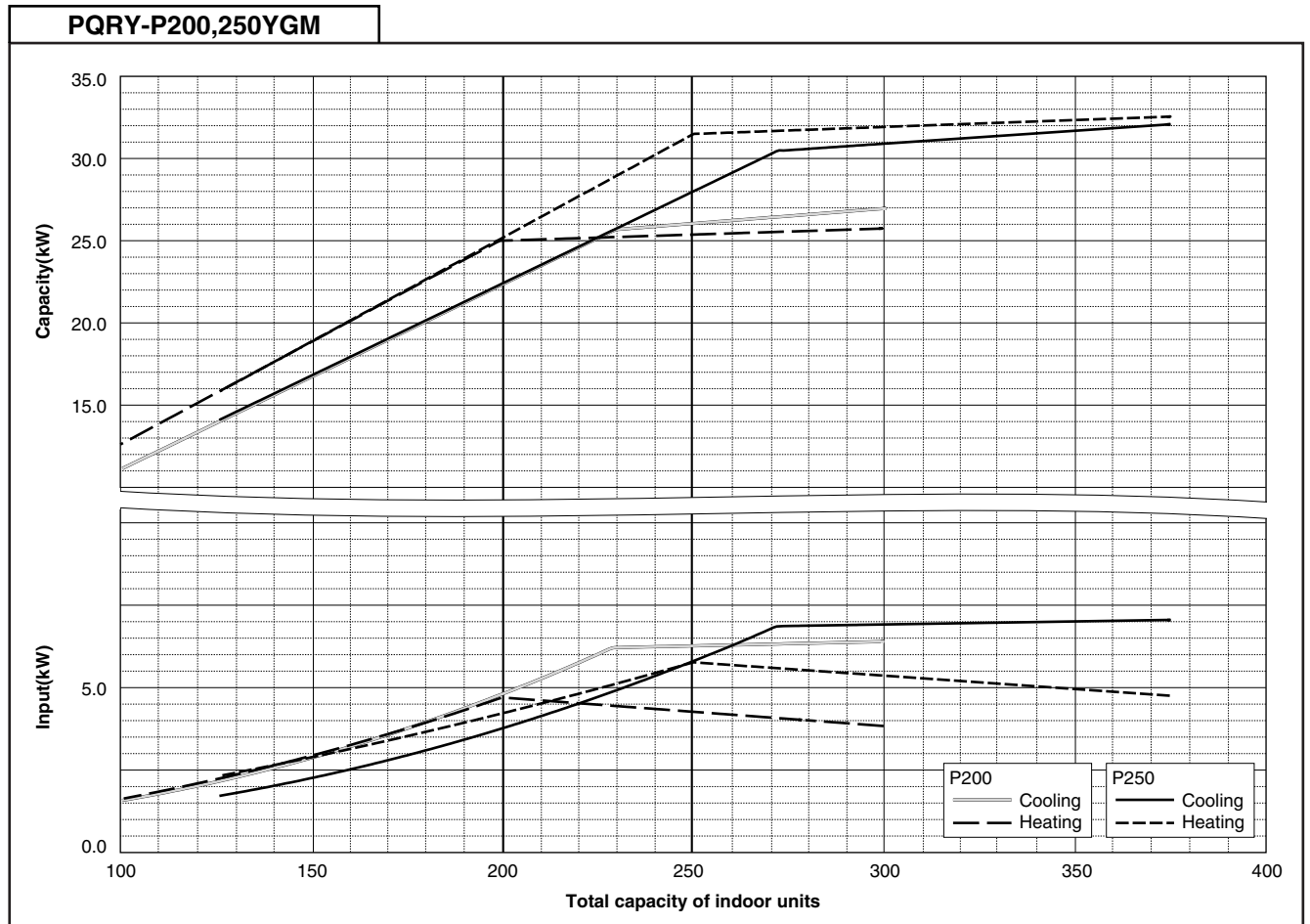

## 2-3. Correction by refrigerant piping length

CITY MULTI™ system can extend the piping flexibly within its limitation for the actual situation. Yet, a decrease of cooling/heating capacity could happen correspondently. Using following correction factor according to the equivalent length of the piping shown at 2.3a and 2.3b, the capacity can be observed. 2.3c shows how to obtain the equivalent length of piping.

### 2-3a. Cooling capacity correction

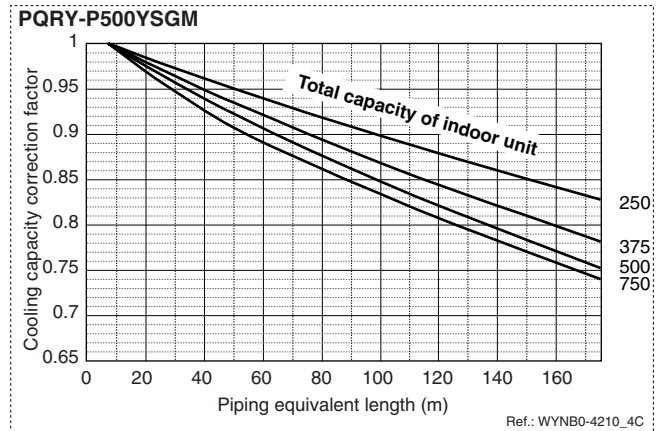
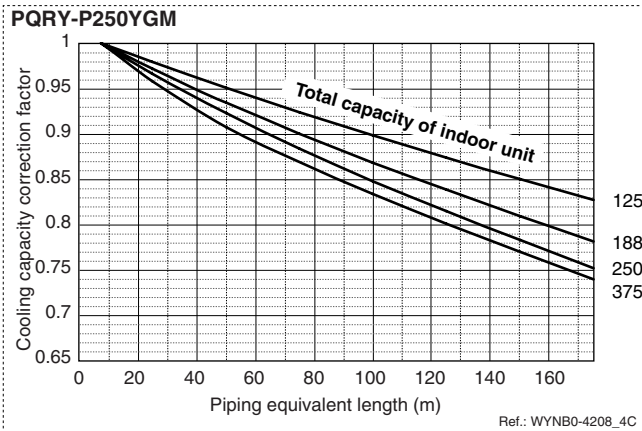
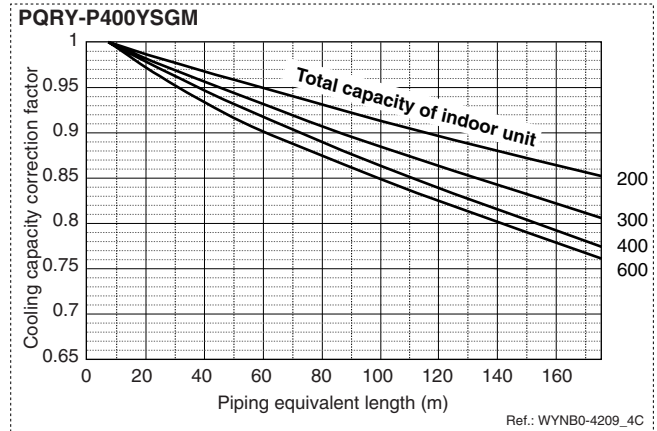
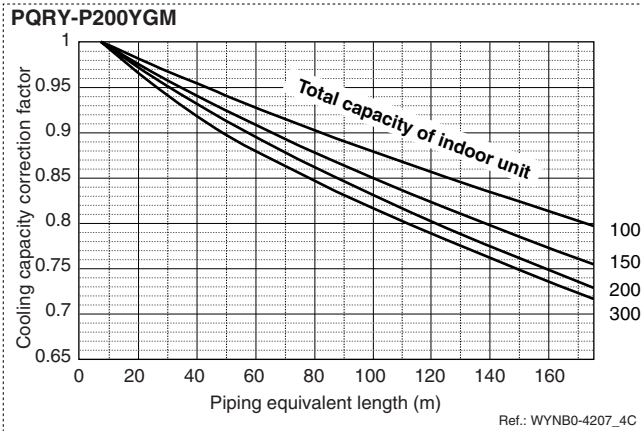

### 2-3. Correction by refrigerant piping length

CITY MULTI™ system can extend the piping flexibly within its limitation for the actual situation. Yet, a decrease of cooling/heating capacity could happen correspondently. Using following correction factor according to the equivalent length of the piping shown at 2.3a and 2.3b, the capacity can be observed. 2.3c shows how to obtain the equivalent length of piping.

#### 2-3b. Heating capacity correction

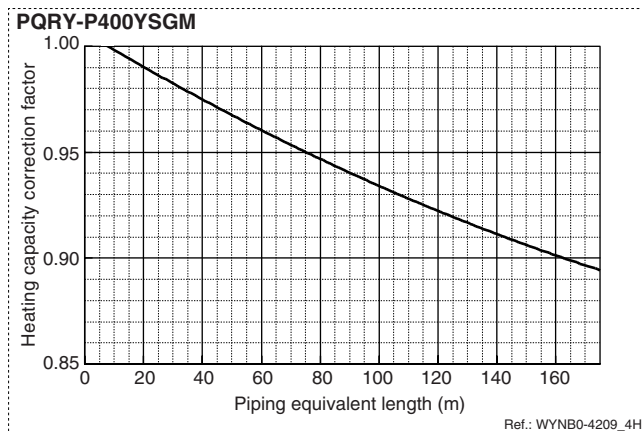
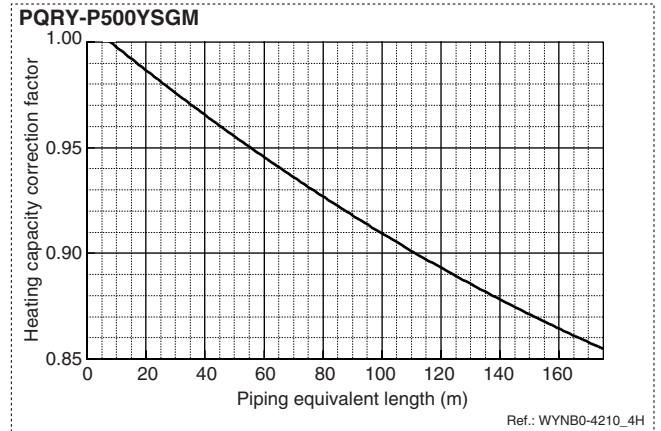
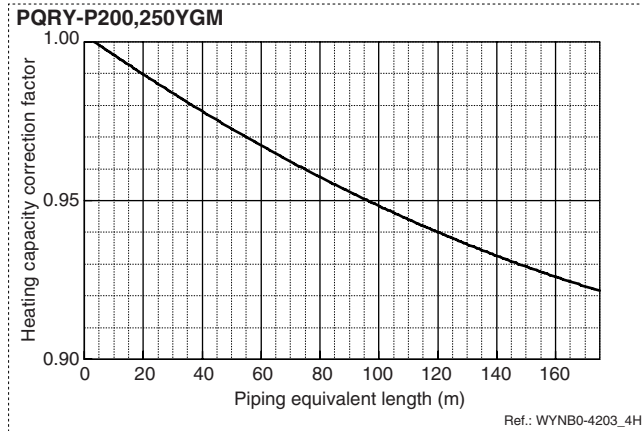

#### 2-3c. How to obtain the equivalent length of piping

- 1 **PQHY, PQRY-P200YGM**  
Equivalent length = (Actual piping length to the farthest indoor unit) + (0.47 x number of bent on the piping) m
- 2 **PQHY, PQRY-P250YGM**  
Equivalent length = (Actual piping length to the farthest indoor unit) + (0.50 x number of bent on the piping) m
- 3 **PQHY, PQRY-P400YSGM**  
Equivalent length = (Actual piping length to the farthest indoor unit) + (0.50 x number of bent on the piping) m
- 4 **PQHY, PQRY-P500YSGM**  
Equivalent length = (Actual piping length to the farthest indoor unit) + (0.50 x number of bent on the piping) m

2-4. Temp. range of running

• Cooling

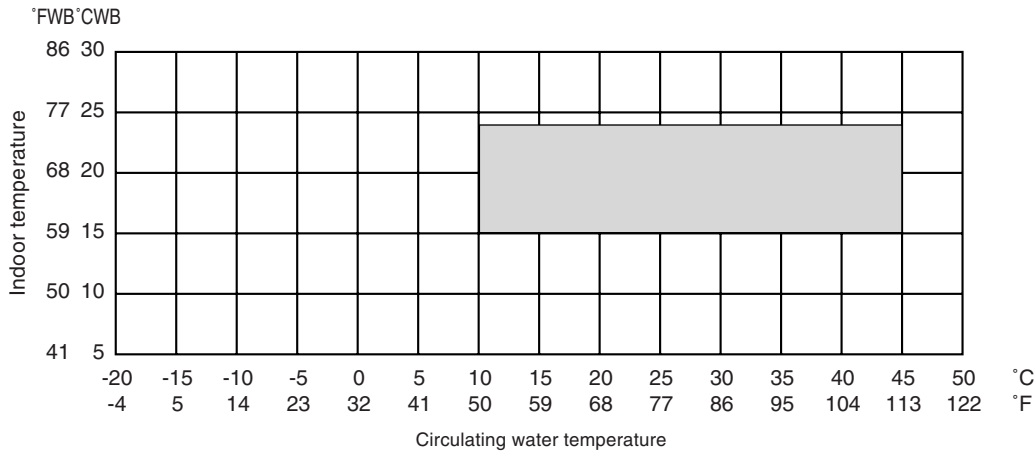

• Heating

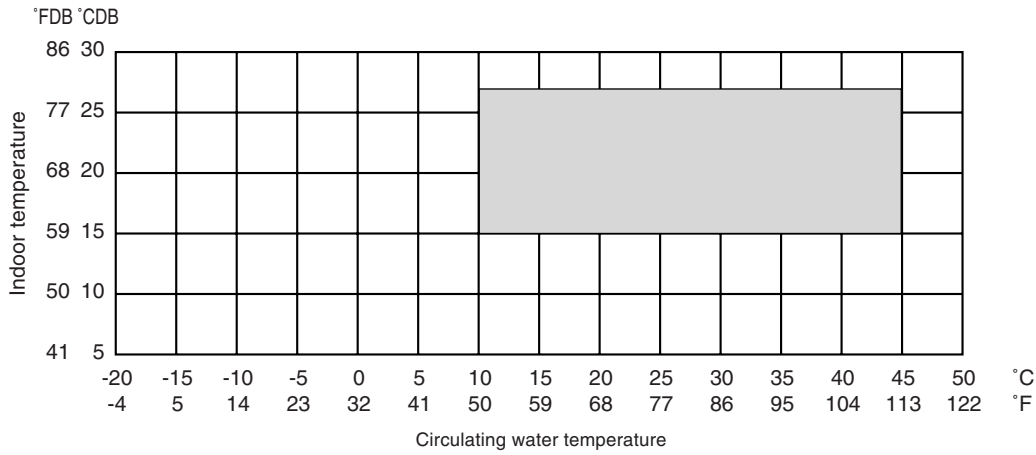

Ref.: tr-ygm-w

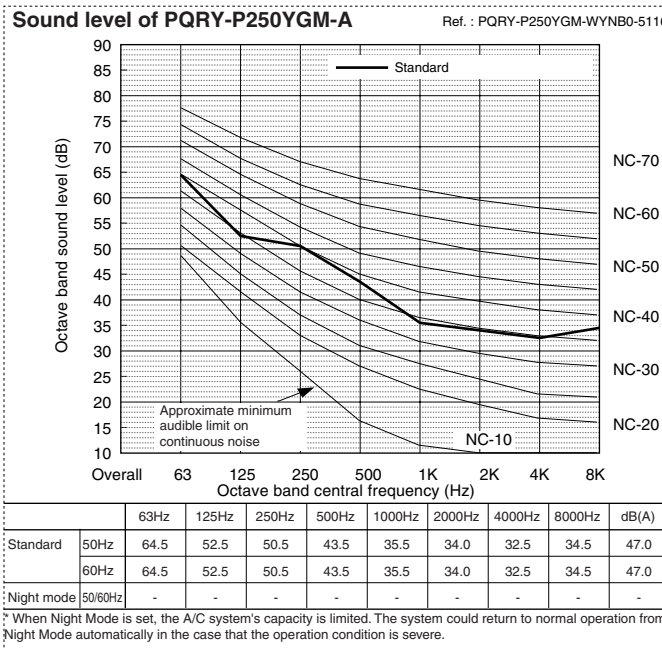
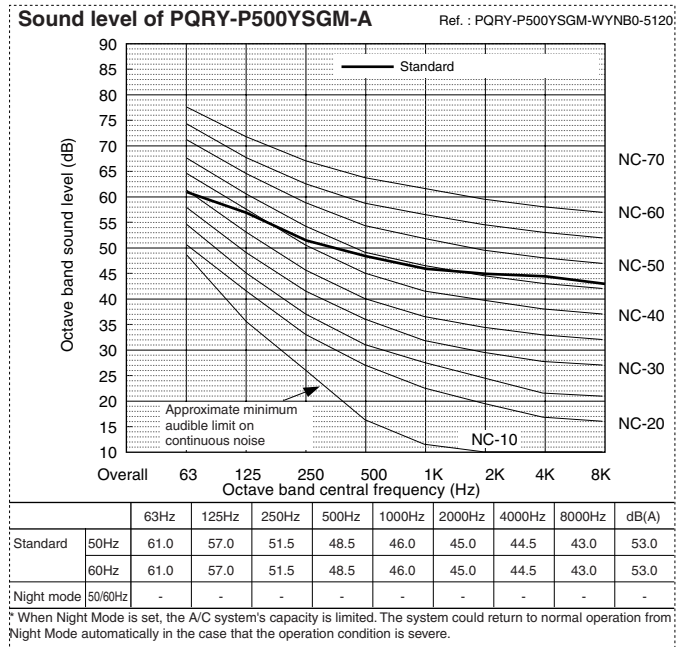
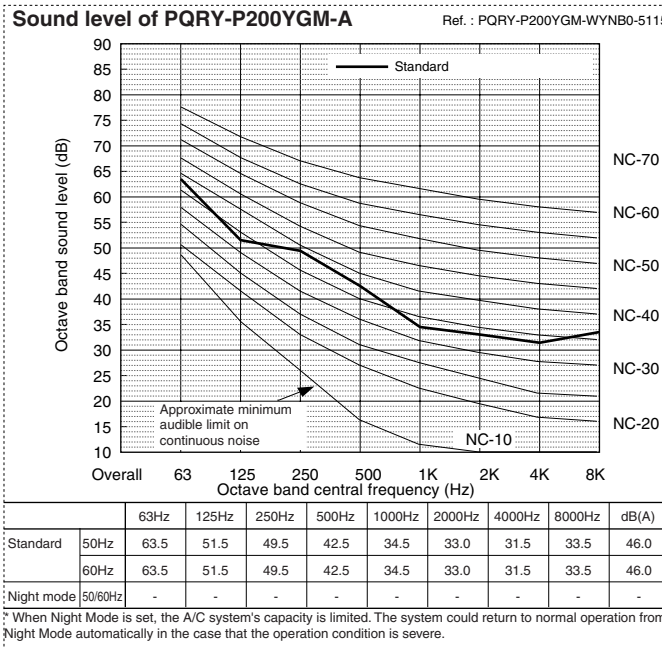
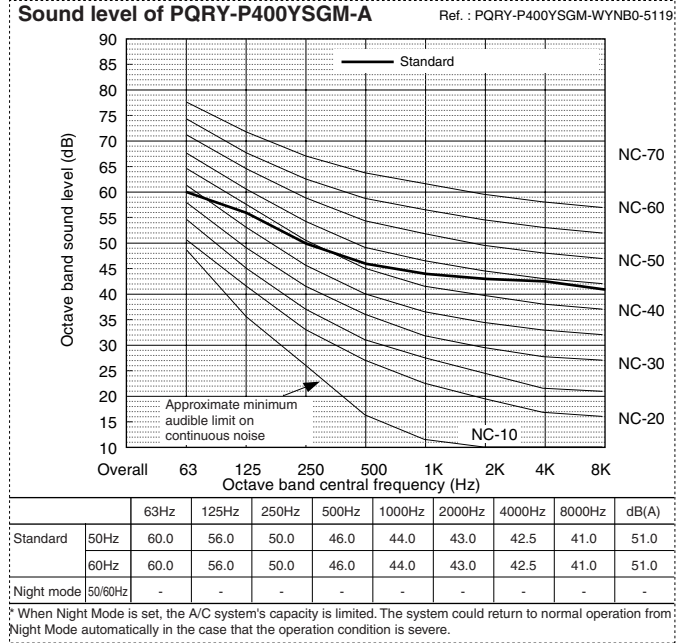
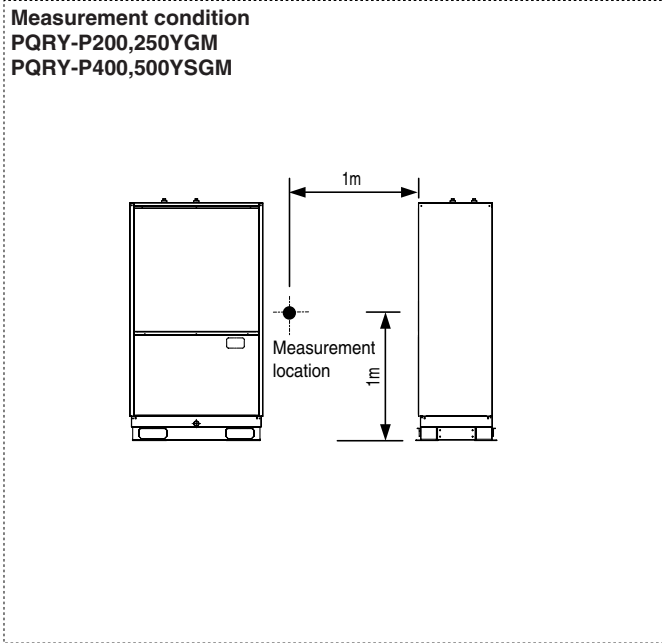

PQRY-P200,250YGM-A

Drw. : OU-W663144  
Unit : mm

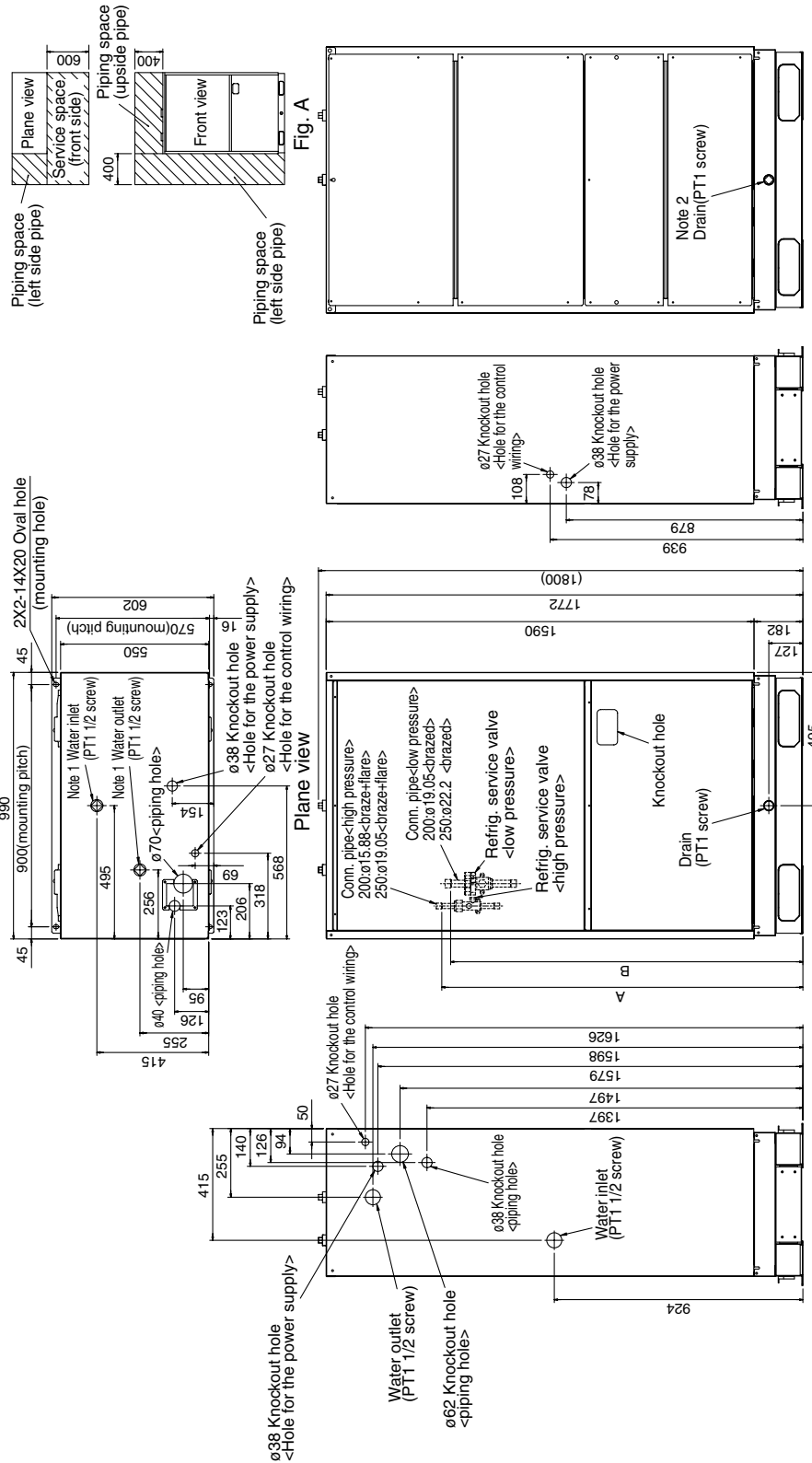

Model	A	B
P200	1347	1309
P250	1342	1319

Left side view

- [Accessories]
- Refrigerant (low pressure) conn. pipe..... 1pc.  
(Already installed on the unit)
  - Refrigerant (high pressure) conn. pipe..... 1pc.  
(Packaged in the accessory kit)
  - Packing for conn. pipe..... 1pc.  
(Attached near the ball valve)
  - Bushing..... 2pcs.

Front view

- Note 1. Close a hole of the water piping, the refrigerant piping, the power supply, and the control wiring and unused knockout holes with the putty etc. so as not to infiltrate rain water etc. (field erection work).
2. At the time of product shipment, the front side piping specification serves as the local drainage connection. When connecting on the rear side, please remove the rear side plug sealing corks, and attach a front side. Ensure there is no leak after the attachment has been fitted.
3. Take notice of service space as Fig. A. (In case of single installation, 600mm or more of back space as front space makes easier access when servicing the unit from rear side.)
4. In case the temperature around the Heat source unit has possibility to drop under 0°C, be careful for the following point to prevent the pipe burst by the water pipe freeze-up.  
-Circulate the water all the time even if the Heat source unit is not in operation.  
-Drain the water from inside of the Heat source unit when the Heat source unit will not operate for a long term.

Right side view

Rear view

Fig. A



PQRY-P400,500YSGM-A

Draw. : OU-W663146  
Unit : mm

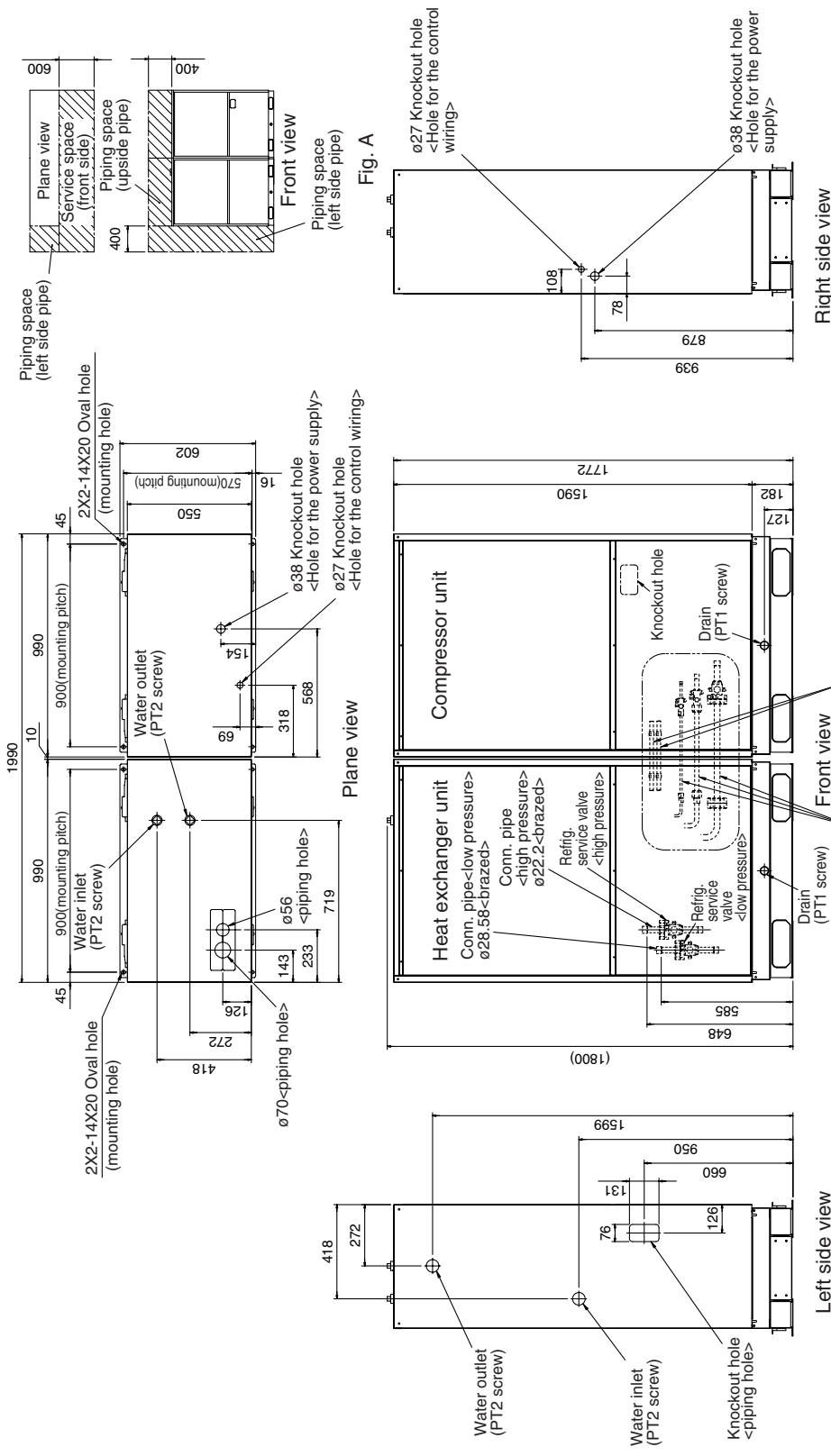

- [Accessories]
- Refrigerant conn. pipe..... 2pcs.
  - Refrigerant conn. pipe between Heat exchanger unit and Compressor unit (Packaged in the accessory kit)..... 2pcs.
  - Refrigerant conn. pipe between Heat exchanger unit and Compressor unit (Packaged in the accessory kit)..... 2pcs.
  - ø19.05 <braze-flare>..... 2pcs.
  - ø28.58 <braze-flare>..... 2pcs.
  - Packing for conn. pipe (Attached near the ball valve)..... 4pcs.
  - Bushing..... 2pcs.
  - External heater adapter..... 1set

- Note 1.** Close a hole of the water piping, the refrigerant piping, the power supply, and the control wiring and unused knockout holes with the putty etc. so as not to infiltrate rain water etc. (field erection work).
- 2.** At the time of product shipment, the front side piping specification serves as the local drainage connection. When connecting on the rear side, please remove the rear side plug sealing corks, and attach a front side. Ensure there is no leak after the attachment has been fitted.
- 3.** Take notice of service space as Fig. A. (In case of single installation, 600mm or more of back space as front space makes easier access when servicing the unit from rear side.)
- 4.** In case the temperature around the Heat source unit has possibility to drop under 0°C, be careful for the following point to prevent the pipe burst by the water pipe freeze-up.  
 - Circulate the water all the time even if the Heat source unit is not in operation.  
 - Drain the water from inside of the Heat source unit when the Heat source unit will not operate for a long term
- 5.** Use the external heater adapter for water Heat source (option) to take length (more than 2m) between Heat exchanger unit and Compressor unit.

PQRY-P200,250YGM-A,P400,500YSGM-A

Draw. : OU-W274643

<Symbol explanation>

Symbol	Name
ACCT	AC Current Sensor
DCCT	DC Current Sensor
DCL	DC reactor (Power factor improvement)
52C	Magnetic contactor (Inverter main circuit)
MF1	Fan motor (Radiator panel)
CH11	Case heater(Compressor)
21SA4	4-way valve
SV1	Solenoid valve
SV4a,b,c,d	Solenoid valve (Discharge-suction bypass)
SV5a,b	Solenoid valve (Heat exchanger capacity control)
SV7a,b,c	Solenoid valve (Heat exchanger capacity control)
LEV1	Electronic expansion valve (Sub-cool coil bypass)
LEV2	Electronic expansion valve (Heat exchanger for inverter)
TH11	Thermistor (Discharge pipe temp. detect)
TH5	Pipe temp.detect
TH6	Water temp.detect
TH7	Liquid outlet temp.detect at sub-cool
TH8	Bypass outlet temp.detect at sub-cool
TH9	Freeze prevention sensor
TH9S1	Outlet temp.detect of heat exchanger for inverter
63H	Radiator panel temp. detect
63HS	High pressure sensor
63LS	Low pressure sensor
L1L2	Choke coil(Transmission)
Z20	Function device
⊕	Earth terminal

<Difference of appliances>

Model name	#2	#3
PQRY-P200P250YGM-A	X	X
PQRY-P400P500YSGM-A	○	○
PQRY-P200P250YGM-A	X	○
PQRY-P400P500YSGM-A	○	○

\*#1 Function according to switch operation.  
(SW4-7:CN3D 1-2P and CN3D 1-3P,  
SW3-3:CN51 3-5P)

SW4-7:OFF (Compressor ON/OFF and NIGHT MODE)

CN3D	Compressor	NIGHT MODE
1-3P	ON/OFF	1-2P MODE
ON	ON	OPEN
OFF	OFF	SHORT
SHORT	OFF	ON

SW4-7:ON (STEP DEMAND)	CN3D 1-2P	SHORT
CN3D 1-3P	OPEN	100%
	OPEN	75%
	OPEN	50%
	OPEN	25%
	OPEN	0%
	SHORT	50%

SW3-3	CN51 3-5P	ON	water freeze signal
ON			
OFF			

CN3N 1-3P	CN3N 1-2P	OPEN	SHORT
CN3N 1-3P		OPEN	SHORT
		Auto change over OFF	COOL
		Auto change over ON	HEAT

\*#4 Auto change over:(CN3N 1-2P, 1-3P):PQRY only

\*#5 " is on the Heat exchanger unit side for P400/500 type.

NOTE:The broken lines indicate field wiring.

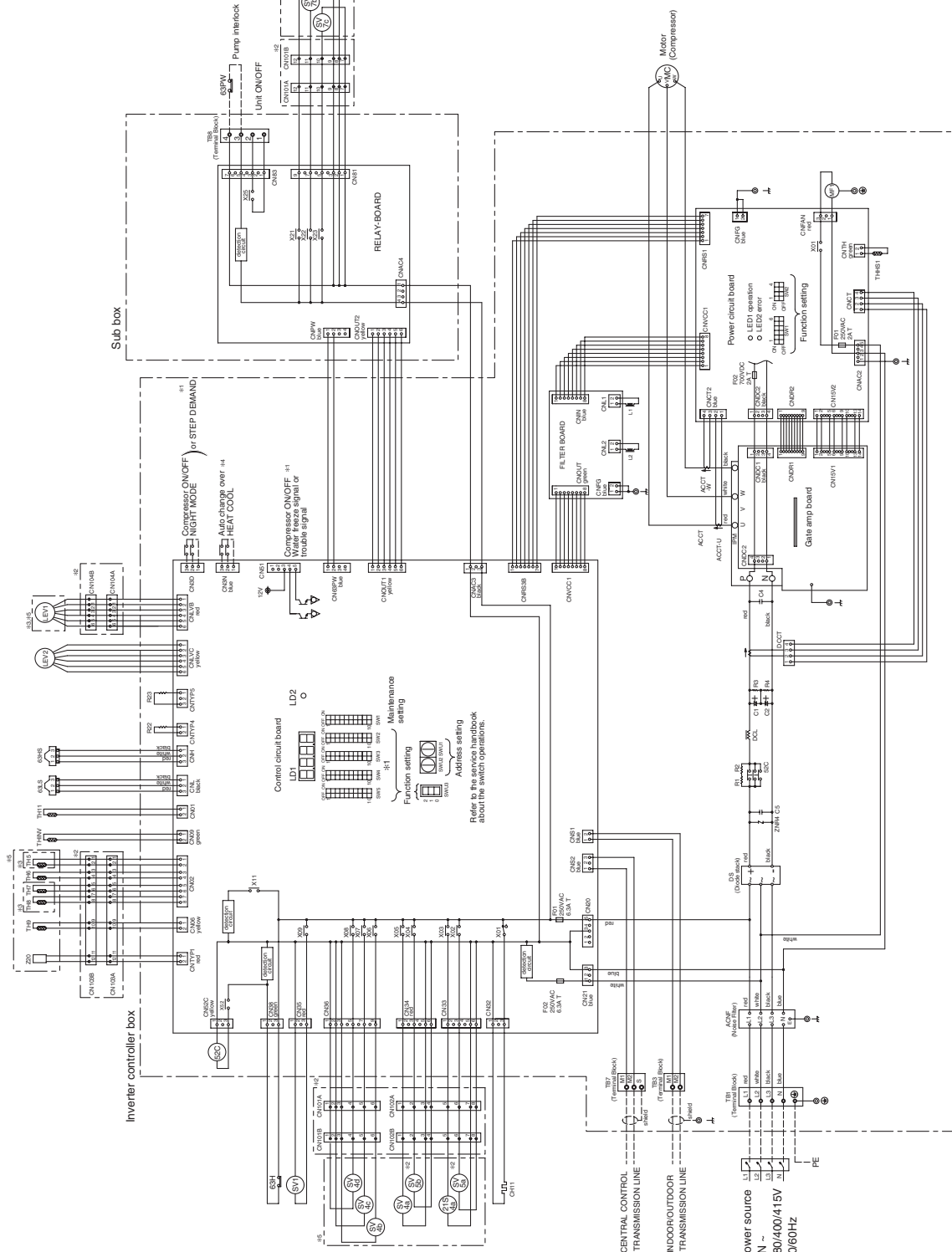

PQRY-P200,250YGM-A

Drw. : RC\_WYNA1-1132-13

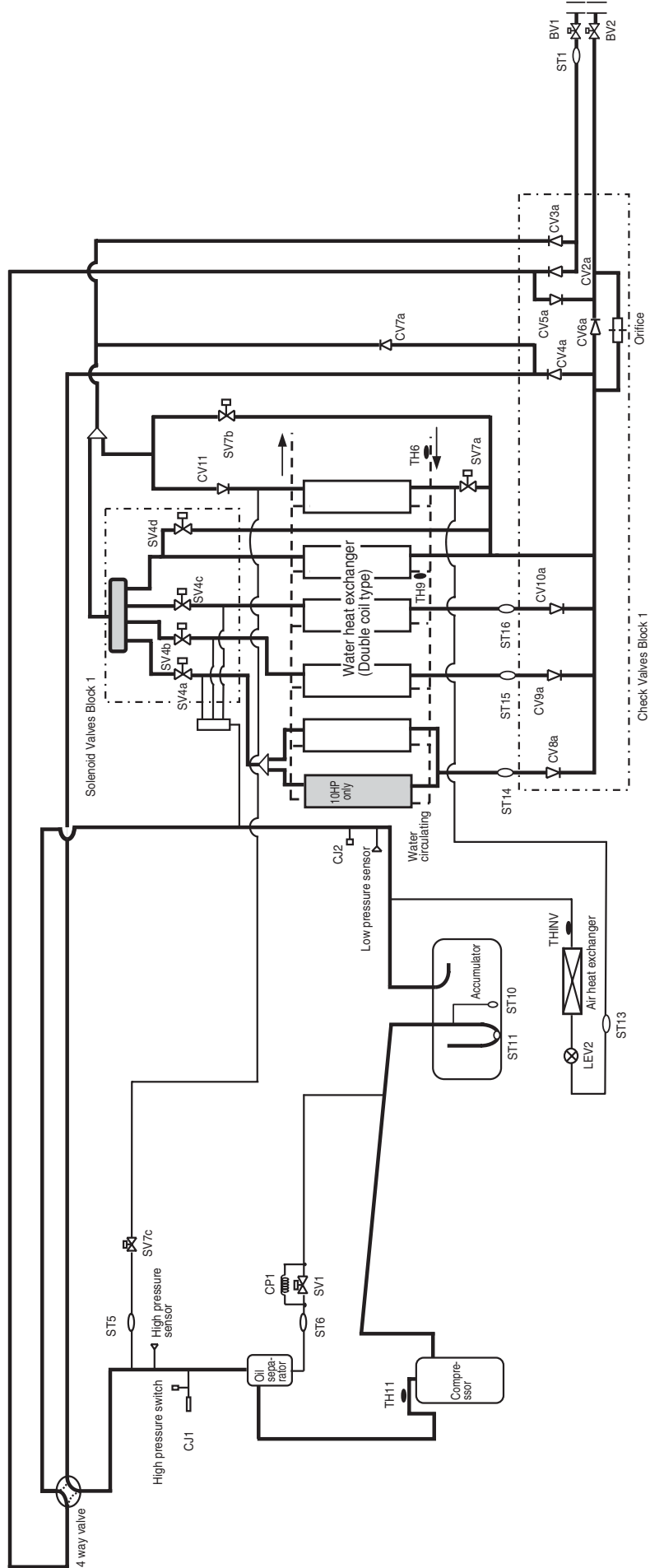

PQRY-P400,500YSGM-A

Drw. : RC\_WYNA1-1132-14

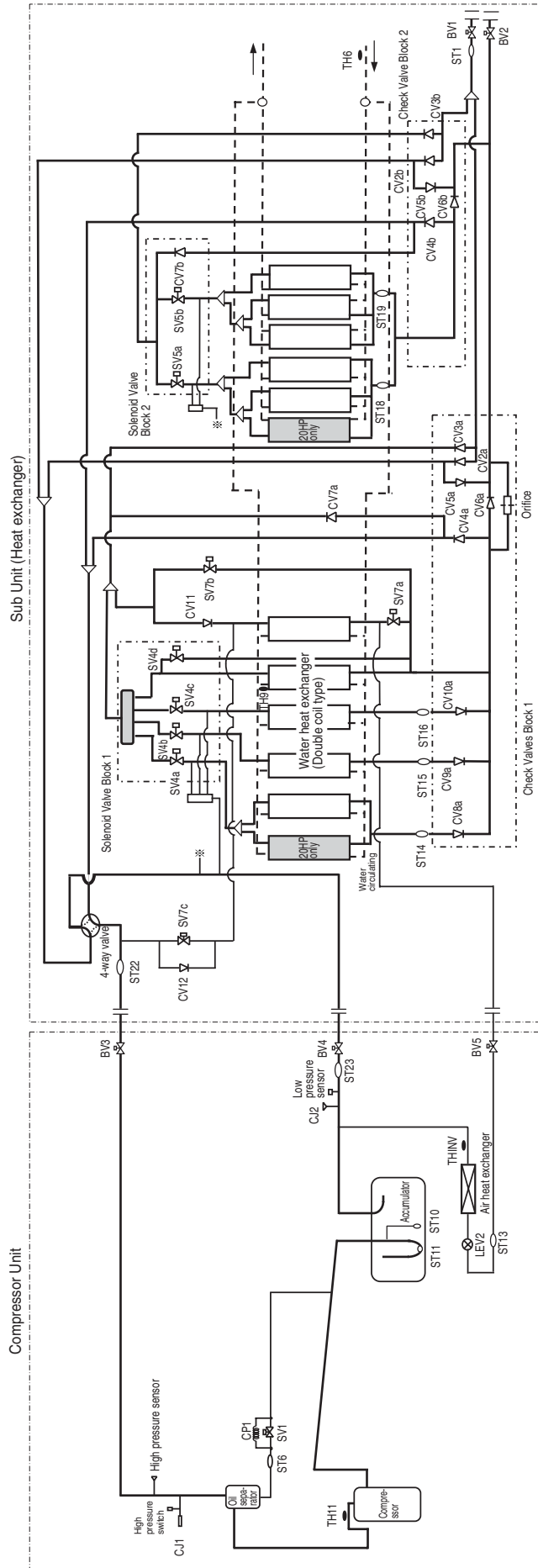

7-1. Designing of water circuit system

1) Example of basic water circuit

The water circuit of the water heat source CITY MULTI connects the heat source unit with the cooling tower/auxiliary heat source/heat storage tank/circulation pump with a single system water piping as shown in the figure below. The selector valve automatically controls to circulate water toward the cooling tower in the cooling season, while toward the heat storage tank in the heating season. If the circulation water temperature is kept in a range of 10~45°C\* regardless of the building load, the water heat source CITY MULTI can be operated for either cooling or heating. Therefore in the summer when only cooling load exists, the temperature rise of circulation water will be suppressed by operating the cooling tower. While in the winter when heating load increases, the temperature of circulation water may be dropped below 10°C. Under such situation, the circulation water will be heated with the auxiliary heat source if it drops below a certain temperature. When the thermal balance between cooling and heating operation is in a correct proportion, the operation of the

auxiliary heat source and cooling tower is not required. In order to control the above thermal balance properly and use thermal energy effectively, utilizing of heat storage tanks, and night-time discounted electric power as a auxiliary heat source will be economical. Meantime as this system uses plural sets of heat source unit equipped with water heat exchangers, water quality control is important. Therefore it is recommended to use closed type cooling towers as much as possible to prevent the circulation water from being contaminated. When open type cooling towers are used, it is essential to provide proper maintenance control such as that to install water treatment system to prevent troubles caused by contaminated circulation water.

\*15~45°C : 50%~150% of indoor units can be connected  
 \*10~40°C : 50%~130% of indoor units can be connected

Example of basic water circuit for water heat source CITY MULTI

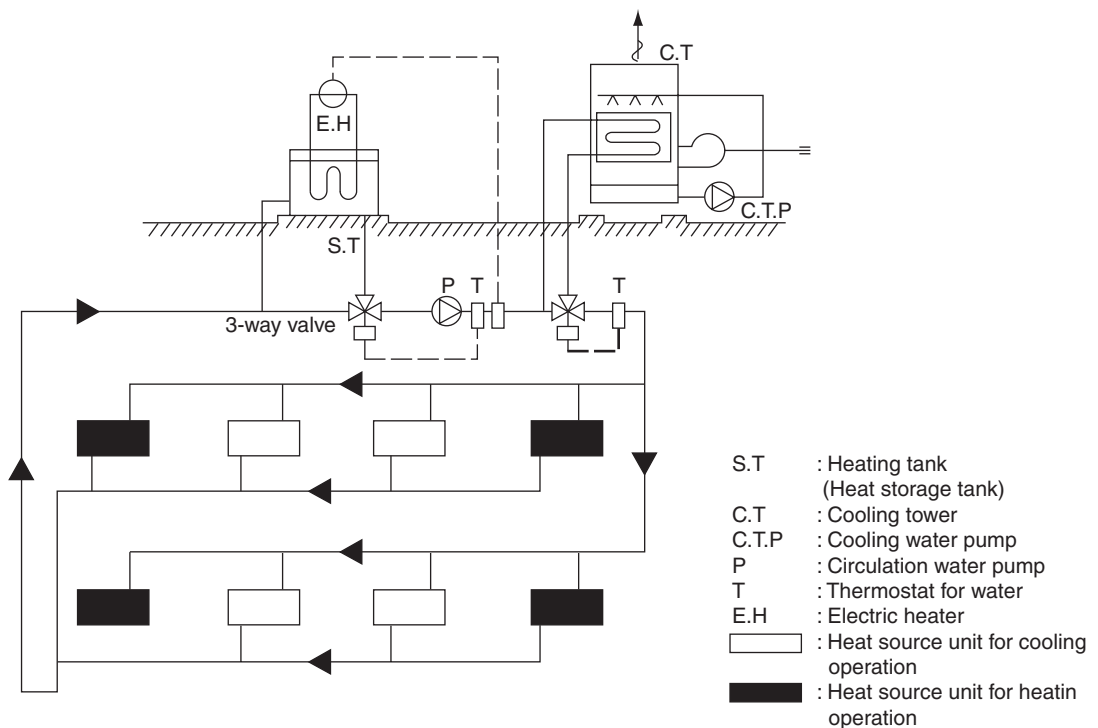

The indoor unit and refrigerant piping system are excluded in this figure.

2) Cooling tower

a) Types of cooling tower

The cooling towers presently used include the open type cooling tower, open type cooling tower + heat exchanger, closed type cooling tower, and air-cooled type cooling tower. However, as the quality control of circulation water is essential when units are installed in decentralized state inside a building, the closed type cooling tower is generally employed in such case.

Although the circulation water will not be contaminated by atmospheric air, it is recommended to periodically blow water inside the system and replenish fresh water instead.

In a district where the coil may be frozen in the winter, it is necessary to apply antifreeze solution to the circulation water, or take freeze protection measures such as to automatically discharge water inside the cooling coil at the stopping of the pump.

When the open type cooling tower is used, be sure to install a water quality control device in addition to the freeze protection measures, as the water may be deteriorated by atmospheric contaminants entered into the cooling tower and dissolved into the circulation water.

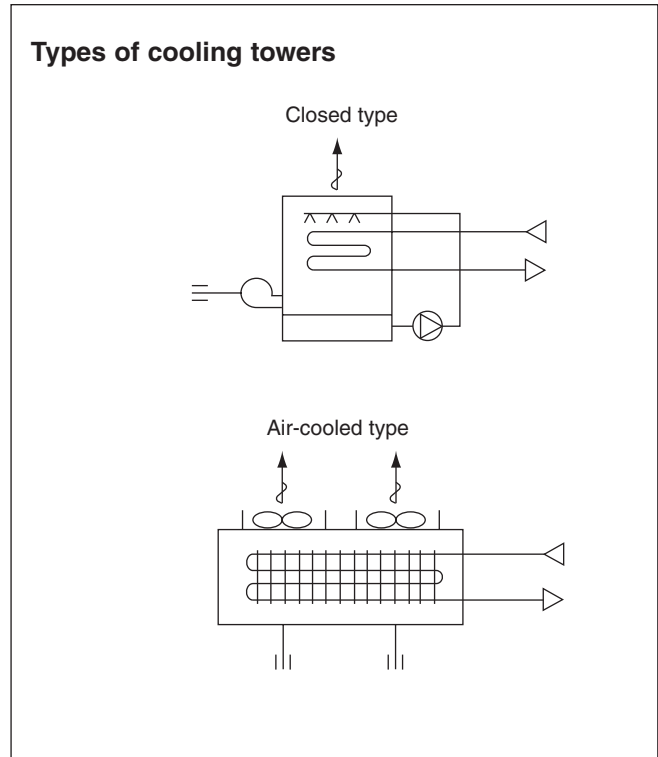

b) Calculation method of cooling tower capacity

All units of the water heat source CITY MULTI may possibly be in cooling operation temporarily (at pulling down) in the summer, however, it is not necessary to determine the capacity according to the total cooling capacity of all CITY MULTI units as this system has a wide operating water temperature range

( 15~45°C : 130% over  
10~45°C : 130% or less ).

It is determined in accordance with the value obtained by adding the maximum cooling load of an actual building, the input heat equivalent value of all CITY MULTI units, and the cooling load of the circulating pumps. Please check for the values of the cooling water volume and circulation water volume.

$$\text{Cooling tower capacity} = \frac{Q_c + 860 \times (\sum Q_w + P_w)}{3,900} \text{ (Refrigeration ton)}$$

Q<sub>c</sub> : Maximum cooling load under actual state (kcal/h)

Q<sub>w</sub> : Total input of water heat source CITY MULTI at simultaneous operation under maximum state (kW)

P<sub>w</sub> : Shaft power of circulation pumps (kW)

### 3) Auxiliary heat source and heat storage tank

When the heating load is larger than the cooling load, the circulation water temperature lowers in accordance with the heat balance of the system. It should be heated by the auxiliary heat source in order to keep the inlet water temperature within the operating range

$$\left( \begin{array}{l} 15^{\circ}\text{C or more : 130\% over} \\ 10^{\circ}\text{C or more : 130\% or less} \end{array} \right)$$

of the water heat source CITY MULTI.

Further in order to operate the water heat source CITY MULTI effectively, it is recommended to utilize the heat storage tank to cover the warming up load in the morning and the insufficient heat amount.

Effective heat utilization can be expected to cover insufficient heat at the warming up in the next morning or peak load time by storing heat by installing a heat storage tank or operating a low load auxiliary heat source at the stopping of the water heat source CITY MULTI. As it can also be possible to reduce the running cost through the heat storage by using the discounted night-time electric power, using both auxiliary heat source and heat storage tank together is recommended.

#### Determining the auxiliary heat source capacity

For the CITY MULTI water heat source system, a heat storage tank is recommended to use. When employment of the heat storage tank is difficult, the warming up operation should be arranged to cover the starting up heating load. Since the holding water inside the piping circuit owns heat capacity and the warming up operation can be assumed for about one hour except that in a cold region, the heat storage tank capacity is required to be that at the maximum daily heating load including the warming up load at the next morning of the holiday.

The effective temperature difference of an ordinary heat storage tank shows about 5deg. even with the storing temperature at 45°C.

However with the water heat source CITY MULTI, it can be utilized as heating heat source up to 15°C with an effective temperature of a high 30deg. approximately, thus the capacity of the heat storage tank can be minimized.

#### a)Auxiliary heat source

The following can be used as the auxiliary heat source.

- Boiler (Heavy oil, kerosine, gas, electricity)
- Electric heat (Insertion of electric heater into heat storage tank)
- Outdoor air (Air-heat source heat pump chiller)
- Warm discharge water (Exhaust water heat from machines inside building and hot water supply)
- Utilization of night-time lighting
- Solar heat

Please note that the auxiliary heat source should be selected after studying your operating environment and economical feasibility.

However the auxiliary heat source capacity should be determined by the daily heating load including warming up load on the week day.

For the load at the next morning of the holiday, heat storage is required by operating the auxiliary heat source even outside of the ordinary working hour.

#### When heat storage tank is not used

$$QH = HC_T \left( 1 - \frac{1}{COP_H} \right) - 1000 \times V_w \times \Delta T - 860 \times P_w$$

QH	: Auxiliary heat source capacity	(kcal/h)
HC <sub>T</sub>	: Total heating capacity of each water heat source CITY MULTI	(kcal/h)
COP <sub>H</sub>	: COP of water heat source CITY MULTI at heating	
V <sub>w</sub>	: Holding water volume inside piping	(m <sup>3</sup> )
ΔT	: Allowable water temperature drop = T <sub>WH</sub> - T <sub>WL</sub>	(°C)
T <sub>WH</sub>	: Heat source water temperature at high temperature side	(°C)
T <sub>WL</sub>	: Heat source water temperature at low temperature side	(°C)
P <sub>w</sub>	: Heat source water pump shaft power	(kW)

**When heat storage tank is used;**

$$QH = \frac{HQ_{1T} \left( 1 - \frac{1}{COP_h} \right) - 860 \times P_w \times T_2}{T_1} \times K \quad (\text{Kcal})$$

- QH<sub>1T</sub> : Total of heating load on weekday including warming up (kcal/day)
- T<sub>1</sub> : Operating hour of auxiliary heat source (h)
- T<sub>2</sub> : Operating hour of heat source water pump (h)
- K : Allowance factor (Heat storage tank, piping loss, etc.) 1.05~1.10

HQ<sub>1T</sub> is calculated from the result of steady state load calculation similarly by using the equation below.  
 $HQ_{1T} = 1.15 \times (\sum Q'a + \sum Q'b + \sum Q'c + \sum Q'd + \sum Q'f) T_2 - \psi (\sum Q'e_1 + \sum Q'e_2 + \sum Q'e_3) (T_2 - 1)$

- Q'a : Thermal load from external wall/roof in each zone (kcal/h)
- Q'b : Thermal load from glass window in each zone (kcal/h)
- Q'c : Thermal load from partition/ceiling/floor in each zone (kcal/h)
- Q'd : Thermal load by infiltration in each zone (kcal/h)
- Q'f : Fresh outdoor air load in each zone (kcal/h)
- Q'e<sub>1</sub> : Thermal load from human body in each zone (kcal/h)
- Q'e<sub>2</sub> : Thermal load from lighting fixture in each zone (kcal/h)
- Q'e<sub>3</sub> : Thermal load from equipment in each zone (kcal/h)
- ψ : Radiation load rate 0.6~0.8
- T<sub>2</sub> : Air conditioning hour

**b) Heat storage tank**

Heat storage tank can be classified by types into the open type heat storage tank exposed to atmosphere, and the closed type heat storage tank with structure separated from atmosphere. Although the size of the tank and its installation place should be taken into account, the closed type tank is being usually employed by con-

sidering corrosion problems.

The capacity of heat storage tanks is determined in accordance with the daily maximum heating load that includes warming up load to be applied for the day after the holiday.

**When auxiliary heat source is operated during operation and even after stopping of water heat source CITY MULTI unit**

$$V = \frac{HQ_{2T} \left( 1 - \frac{1}{COP_h} \right) - 860 \times P_w \times T_2 - QH \times T_2}{\Delta T \times 1000 \times \eta V} \quad (\text{ton})$$

**When auxiliary heat source is operated after stopping of water heat source CITY MULTI unit**

$$V = \frac{HQ_{2T} \left( 1 - \frac{1}{COP_h} \right) - 860 \times P_w \times T_2}{\Delta T \times 1000 \times \eta V} \quad (\text{ton})$$

- HQ<sub>2T</sub> : Maximum heating load including load required for the day after the holiday (kcal/day)
- ΔT : Temperature difference utilized by heat storage tank (deg)
- ηV : Heat storage tank efficiency

$$HQ_{2T} : 1.3 \times (\sum Q'a + \sum Q'c + \sum Q'd + \sum Q'f) T_2 - \psi (\sum Q'e_2 + \sum Q'e_3) (T_2 - 1)$$



4) Piping system

The following items should be kept in your mind in planning / designing water circuits.

- a) All units should be constituted in a single circuit in principle.
- b) When plural numbers of the water heat source CITY MULTI unit are installed, the rated circulating water flow rate should be kept by making the piping resistance to each unit almost same value. As an example, the reverse return system as shown below may be employed.
- c) Depending on the structure of a building, the water circuit may be prefabricated by making the layout uniform.
- d) When a closed type piping circuit is constructed, install an expansion tank usable commonly for a make-up water

tank to absorb the expansion/contraction of water caused by temperature fluctuation.

- e) If the operating temperature range of circulation water stays within the temperature near the normal temperature (summer : 30°C, winter : 20°C), thermal insulation or anti-sweating work is not required for the piping inside buildings.

In case of the conditions below, however, thermal insulation is required.

- When well water is used for heat source water.
- When piped to outdoor or a place where freezing may be caused.
- When vapor condensation may be generated on piping due to an increase in dry bulb temperature caused by the entry of fresh outdoor air.

Y  
R2  
WY  
WR2  
S  
OP

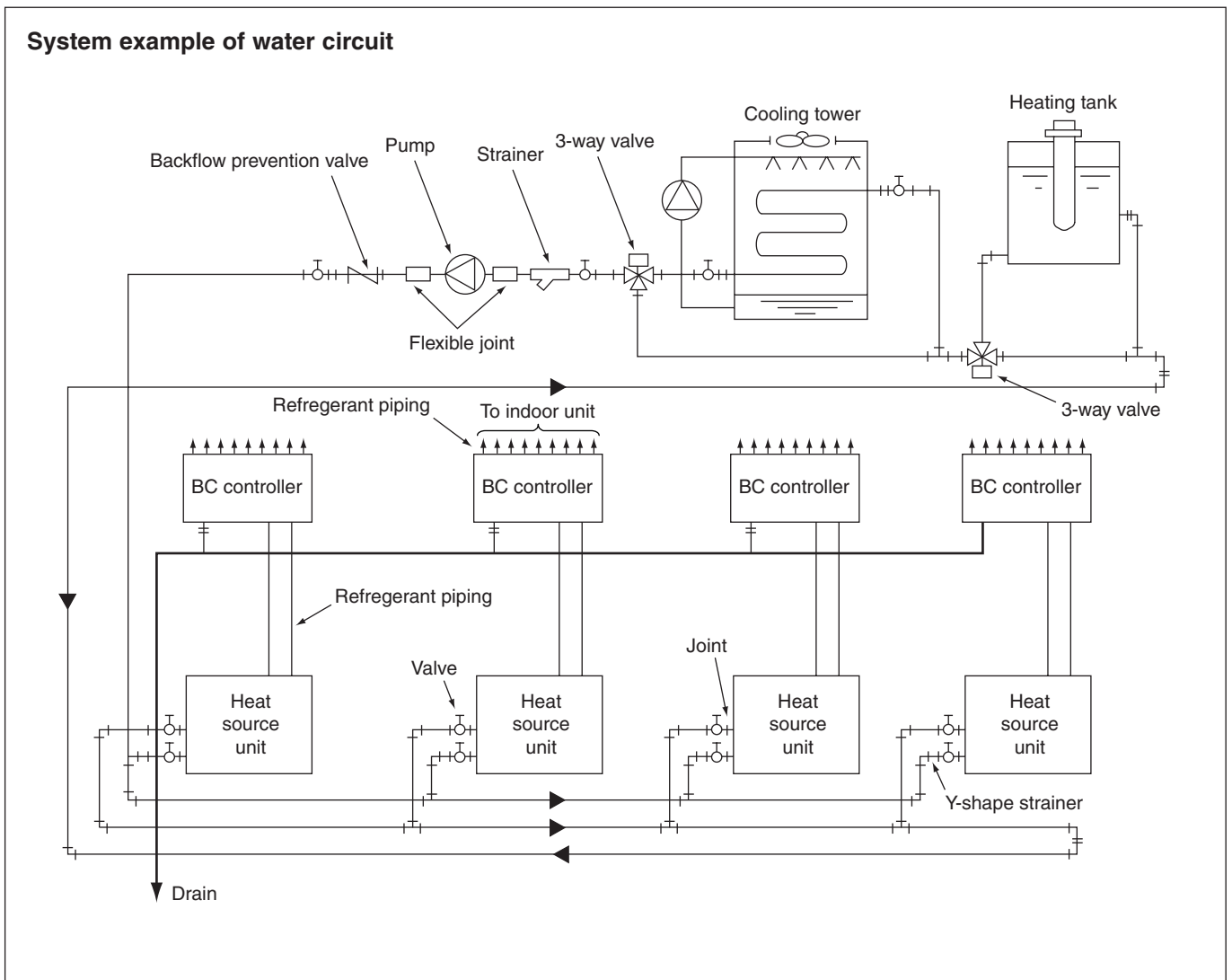

5) Cleaning of water heat exchanger

For the water heat exchanger, scale adheres in less amount generally in the case of closed type cooling towers. However in a long period of use, scale will adhere that may lower the heat exchange capacity and increase the water resistance.

In such case, conduct cleaning work under the procedure given below.

For the water heat exchanger, scale adheres in less amount generally in the case of closed type cooling towers. However in a long period of use, scale will adhere that may lower the heat exchange capacity and increase the water resistance.

The cleaning work procedure generally used is as follows. However as the cleaning agents have various differences in their cleaning effect, corrosion characteristics, processing time, and condensation for use, conduct the work after consulting the relating maker.



a) Still standing method

This method feeds the raw liquid or diluted solution of cleaning agent into the water circuit and leave it for a while, and requires only a simple device.

- Since the cleaning time required differs by the agent of each maker, be sufficiently careful for the time and not to exceed the time specified.

- Fully recover the cleaning liquid through the water discharge plug of the heat exchanger, and then fully clean the water circuit with clean water. If the water washing can not be made sufficiently, neutralization processing will be effective.

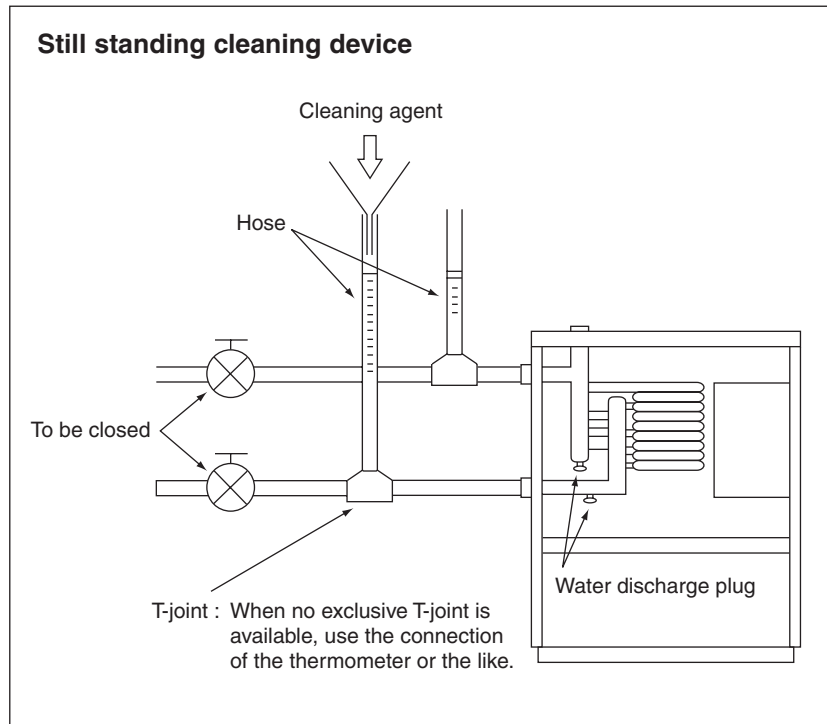

b)Circulation method

Although this method can clean in shorter time than that required by the still standing method, be careful that the circulation pump may be damaged if using cleaning agent with strong corrosive characteristics.

- After completing washing work, fully recover the washing liquid through the water discharge plug installed at the bottom of the piping and that at the heat exchanger.
- Conduct water washing for three times or more after removing cleaning agent. If this can not be made satisfactorily, apply neutralization treatment. Full replacement of water can be ascertained by measuring the PH of the water.
- Note that it may be required to control the cleaning time depending on the scale generation or water quality.
- At cleaning work, remove or shut down the instruments like water pressure gauges so that the cleaning liquid will not enter into them.

- Check for the connections of piping beforehand so that cleaning agent will not leak from the piping during cleaning work.
- Start cleaning operation after fully mixing the cleaning agent with water.
- Cleaning at the earlier timing is recommended as the removal of scale will be difficult if it has accumulated seriously. Periodical cleaning is necessary in a district with inferior water quality.
- Conduct water washing sufficiently with clear water after cleaning work as all cleaning agents own strong acidity.
- To verify the completion of cleaning, remove the hose and observe the inner wall of the piping whether it is clean.
- Be sufficiently careful for fire when using inflammable cleaning agent (GOSPEL R).

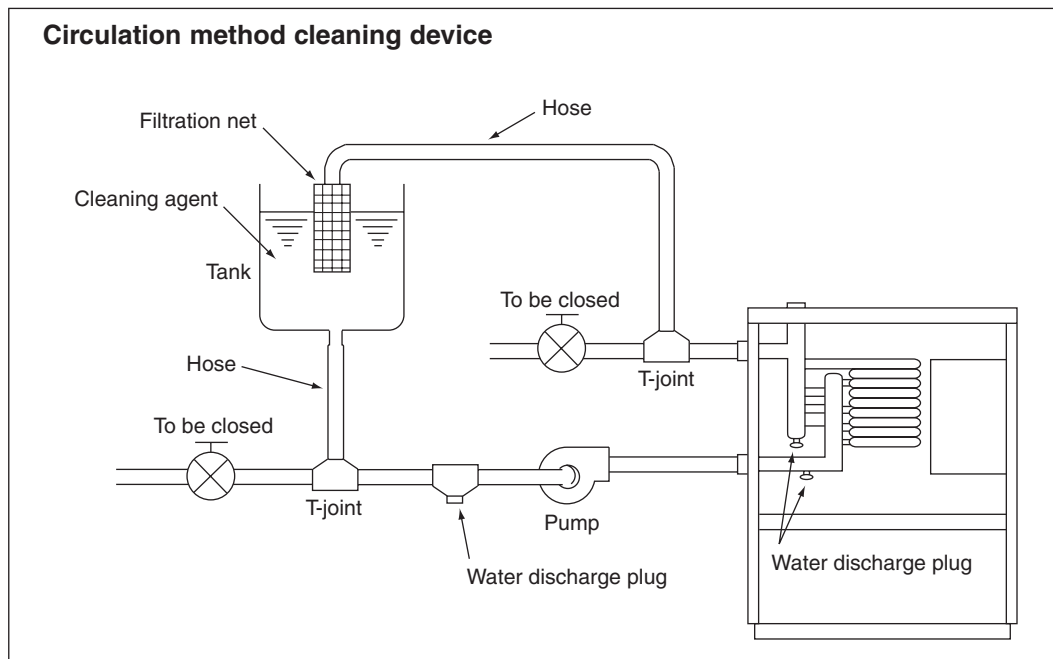

Example of cleaning agents

Name	Shape	Condensation	Time	Makers
CLEARLITE RK	Powder/Liquid	10~20%	2~3Hr.	Koei Kagaku
CLEARLITE ACE	Powder/Liquid	3~5%	1~3Hr.	Koei Kagaku
GOSPEL R	Liquid	7% ( Upper limit 10%, lower limit 5% )	1~4Hr.	Gospel Kako
GOSPEL SR	Powder			Marusan
ADDITION DR	Powder			Seiwa kogyo
SS-100	Liquid			Saver Kagaku
NEOLUX F	Powder			
DISCALER	Powder	4~7%		

6) Practical System Examples and Circulation Water Control

Since the water heat source CITY MULTI is of water heat source system, versatile systems can be constituted by combining it with various heat sources.

The practical system examples are given below.

Either cooling or heating operation can be performed if the circulation water temperature of the water heat

source CITY MULTI stays within a range of 15~45°C. However, the circulation water temperature near 32°C for cooling and 20°C for heating is recommended by taking the life, power consumption and capacity of the air conditioning units into consideration. The detail of the control is also shown below.

Example-1 Combination of closed type cooling tower and hot water heat storage tank (using underground hollow slab)

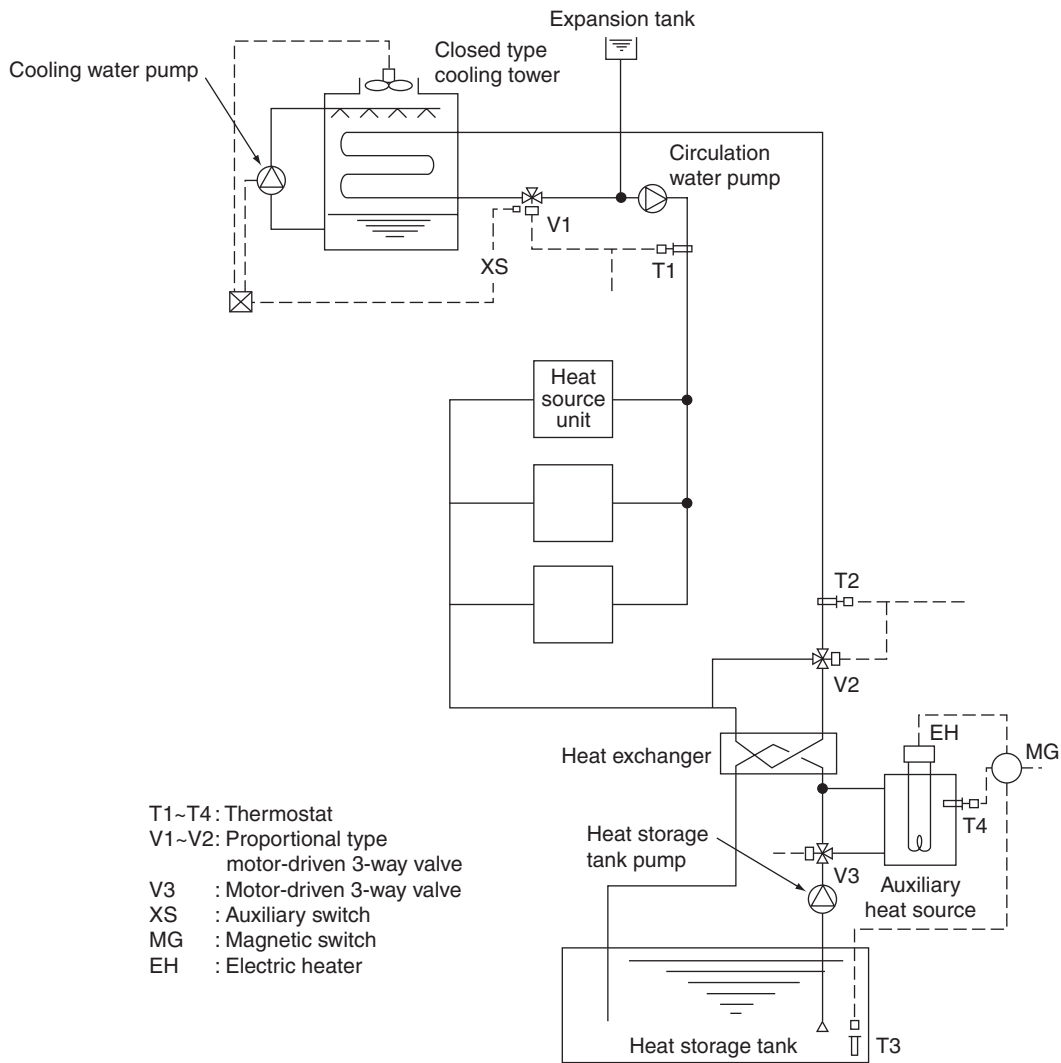

By detecting the circulation water temperature of the water heat source CITY MULTI system with T1 (around 32°C) and T2 (around 20°C), the temperature will be controlled by opening/closing V1 in the summer and V2 in the winter.

In the summer, as the circulation water temperature rises exceeding the set temperature of T1, the bypass port of V1 will open to lower the circulation water temperature. While in the winter, as the circulation water temperature drops, V2 will open following the command of T2 to rise the circulation water temperature.

The water inside the heat storage tank will be heated by the auxiliary heat source by V3 being opened with timer operation in the night-time. The electric heater of the auxiliary heat source will be controlled by T3 and the timer. The start/stop control of the fan and pump of the closed type cooling tower is applied with the step control of the fan and pump following the command of the auxiliary switch XS of V1, that operates only the fan at the light load while the fan and pump at the maximum load thus controlling water temperature and saving motor power.

## Example-2 Combination of closed type cooling tower and hot water heat storage tank

- T1 : Proportional type, insertion system thermostat  
 T2 : Proportional type, insertion system thermostat  
 T3 : Proportional type, insertion system thermostat  
 V1 : Proportional type, motor-driven 3-way valve  
 V2 : Proportional type, motor-driven 3-way valve  
 XS : Auxiliary switch (Duplex switch type)  
 SC : Step controller  
 R : Relay  
 MG : Magnetic

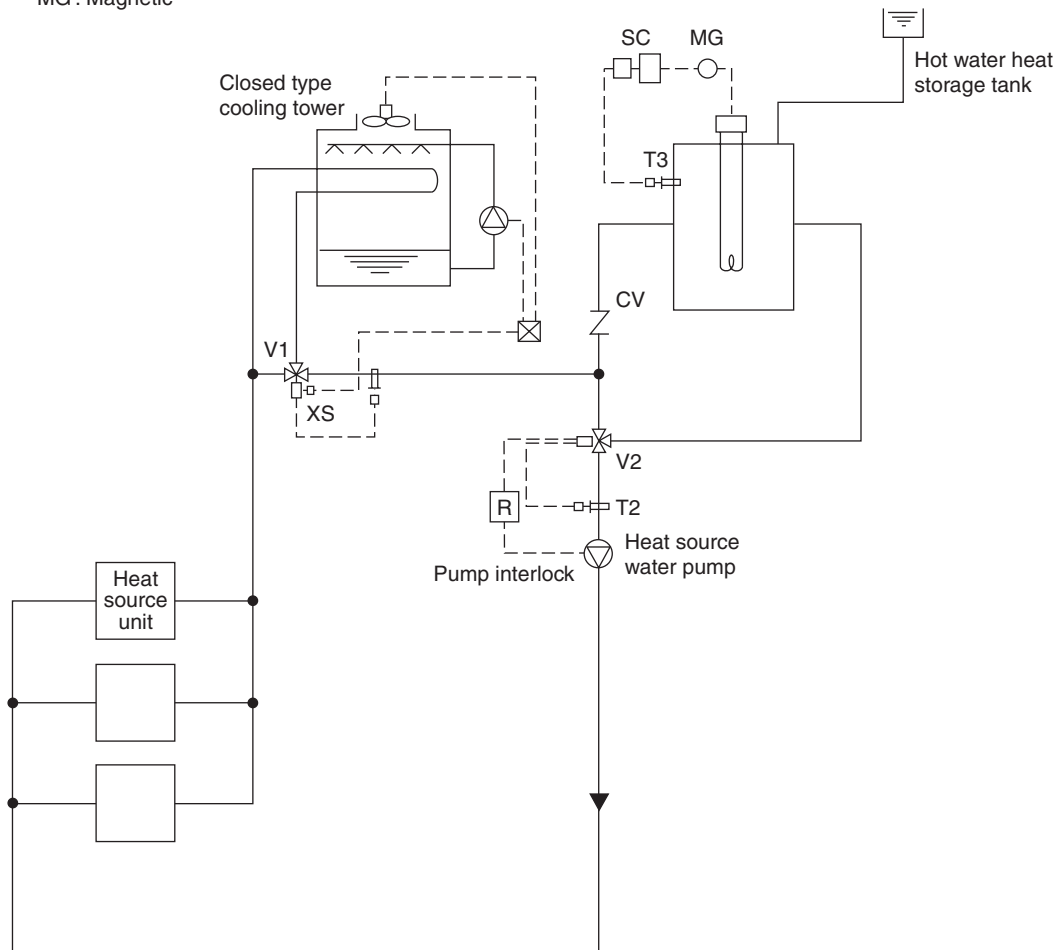

In the summer, as the circulation water temperature rises exceeding the set temperature of T1, the bypass port of V1 will open to lower the circulation water temperature. In the winter, if the circulation water temperature stays below 25°C, V2 will open/close by the command of T2 to keep the circulation water temperature constant.

The temperature of the hot water inside the heat storage tank will be controlled through the step control of the electric heater by step controller operation following the command of T3.

During the stopping of the heat source water pump, the bypass port of V2 will be closed fully by interlocking thus preventing the high temperature water from entering into the system at the starting of the pump.

The start/stop control of the fan and pump of the closed type cooling tower is applied with the step control of the fan and pump following the command of the auxiliary switch XS of V1, that operates only the fan at the light load while the fan and pump at the maximum load thus controlling water temperature and saving motor power.

## Example-3 Combination of closed type cooling tower and boiler

- T1 : Proportional type, insertion system thermostat  
 T2 : Proportional type, insertion system thermostat  
 T3 : Proportional type, insertion system thermostat  
 V1 : Proportional type, motor-driven 3-way valve  
 S : Selector switch  
 R : Relay  
 XS : Auxiliary switch (Duplex switch type)

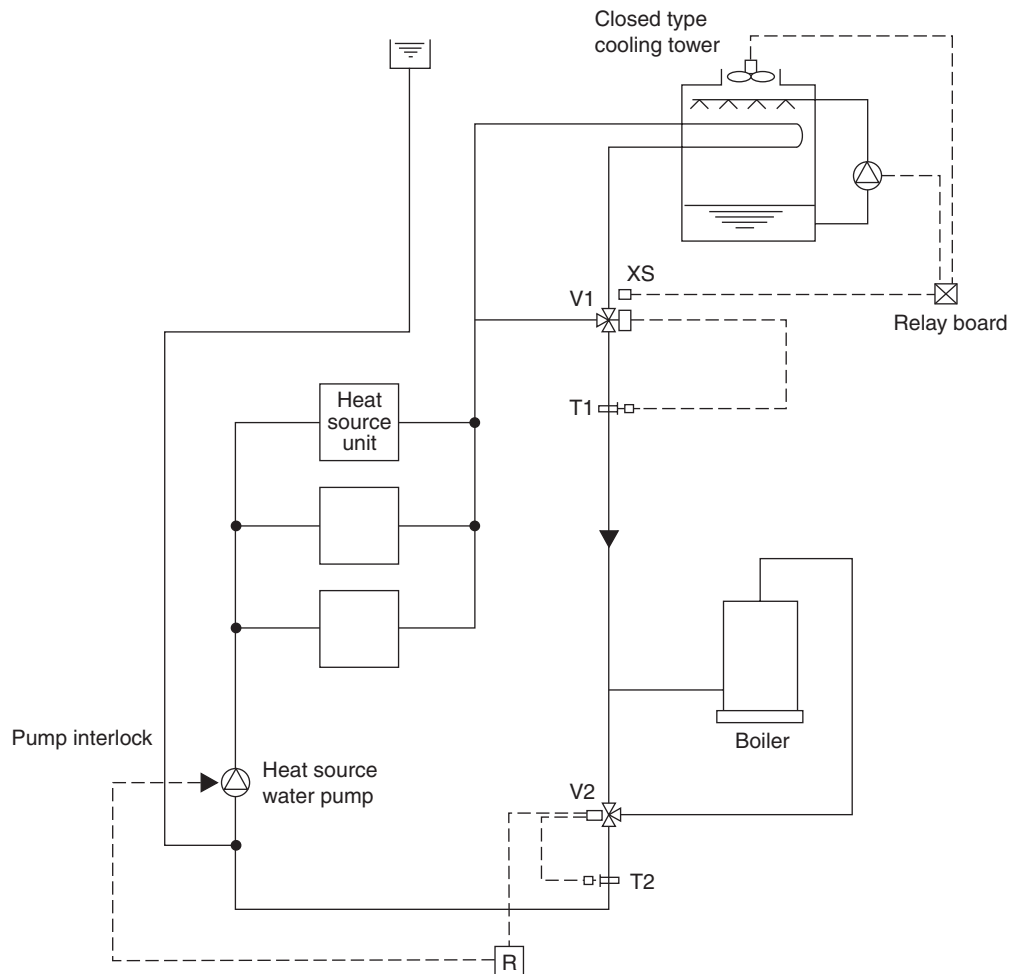

In the summer, as the circulation water temperature rises exceeding the set temperature of T1, the bypass port of V1 will close to lower the circulation water temperature. In the winter, if the circulation water temperature drops below 25°C, V2 will conduct water temperature control to keep the circulation water temperature constant.

During the stopping of the heat source water pump, the bypass port of V2 will be closed fully by interlocking.

The start/stop control of the fan and pump of the closed type cooling tower is applied with the step control following the command of the auxiliary switch XS of V1, thus controlling water temperature and saving motor power.

## Example-4 Combination of closed type cooling tower and heat exchanger (of other heat source)

- T1 : Proportional type, insertion system thermostat  
 T2 : Proportional type, insertion system thermostat  
 V1 : Proportional type, motor-driven 3-way valve  
 V2 : Proportional type, motor-driven 3-way valve  
 S : Selector switch  
 R : Relay  
 XS : Auxiliary switch (Duplex switch type)

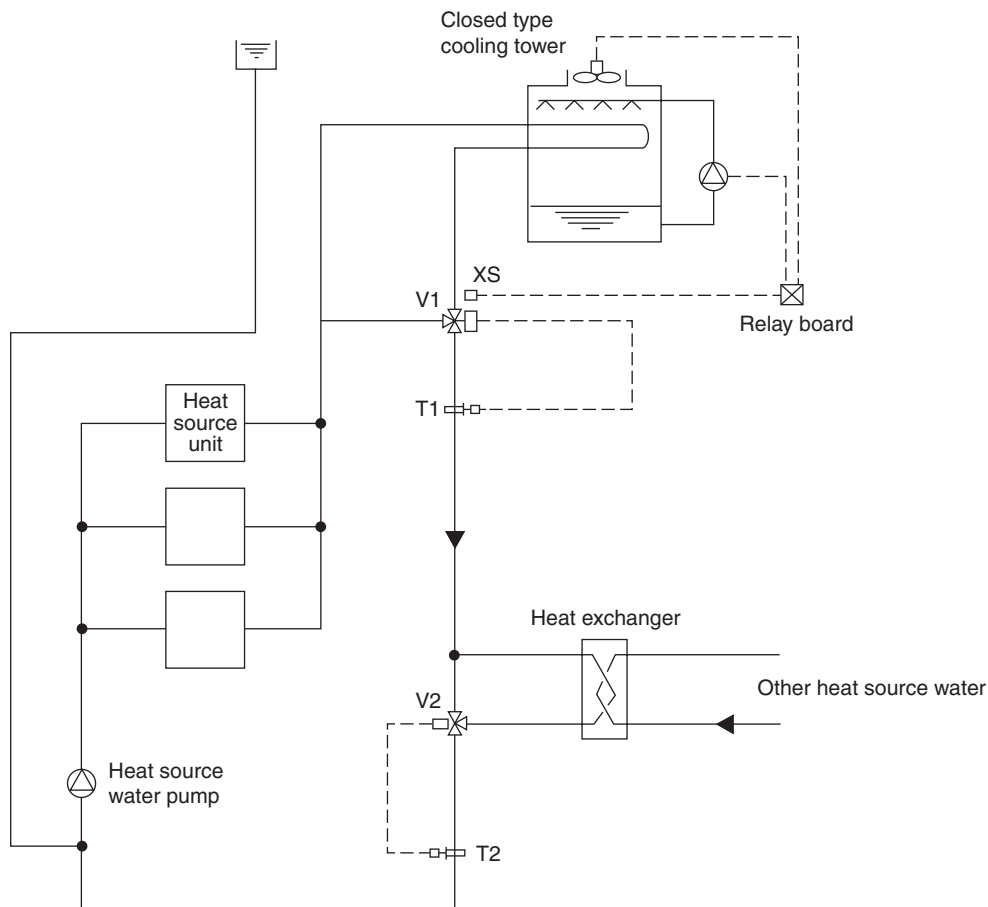

In the summer, as the circulation water temperature rises exceeding the set temperature of T1, the bypass port of V1 will close to lower the circulation water temperature. In the winter, if the circulation water temperature drops below 26°C, V2 will conduct water temperature control to keep the circulation water temperature constant.

During the stopping of the heat source water pump, the bypass port of V2 will be closed fully by interlocking.

The start/stop control of the fan and pump of the closed type cooling tower is applied with the step control following the command of the auxiliary switch XS of V1, thus controlling water temperature and saving motor power.

7) Pump interlock circuit

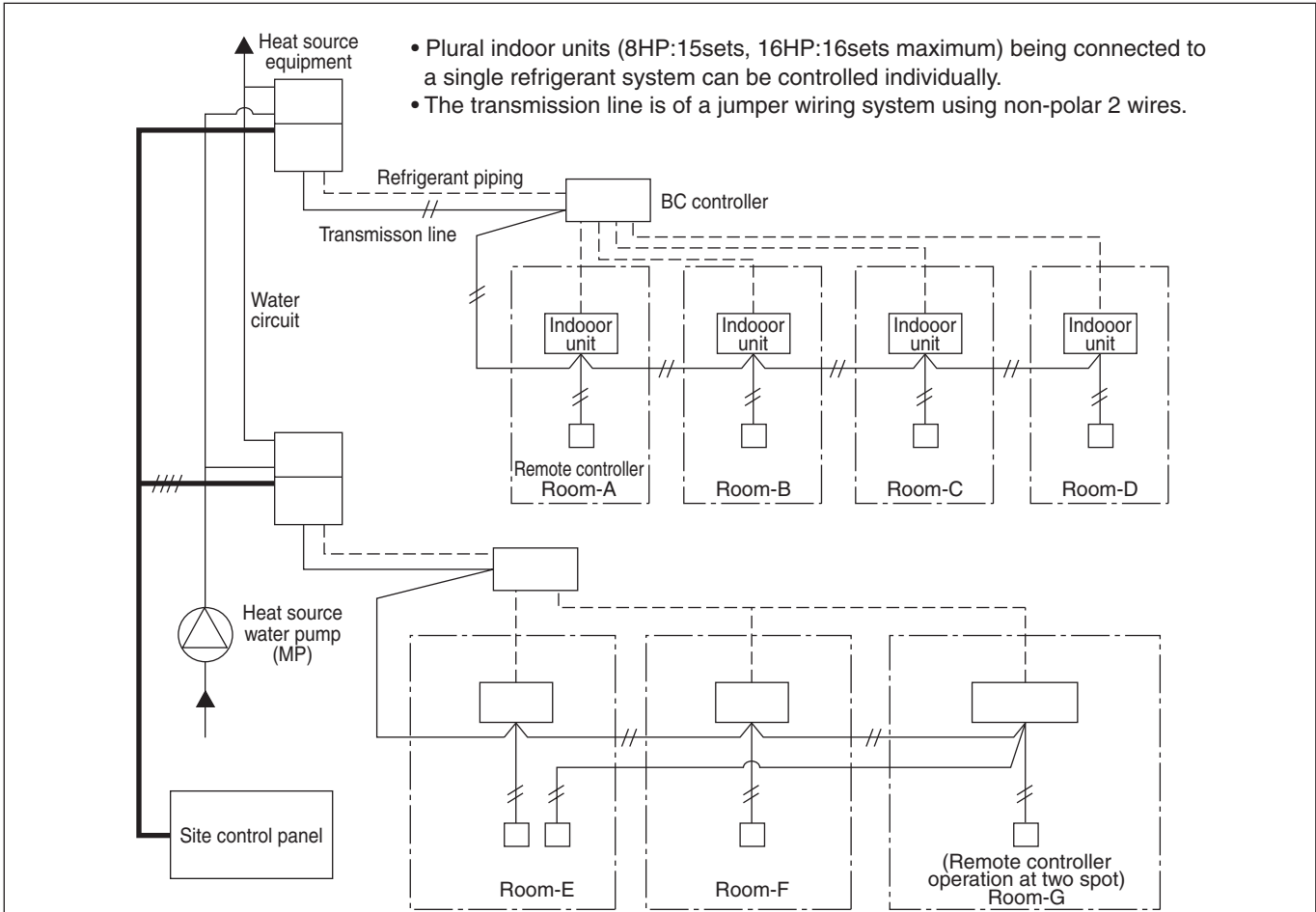

**Wiring diagram**

This circuit uses the "Terminal block for pump interlock (TB8)" inside the electrical parts box of the heat source equipment. This circuit is for interlocking of the heat source equipment operation and the heat source water pump.

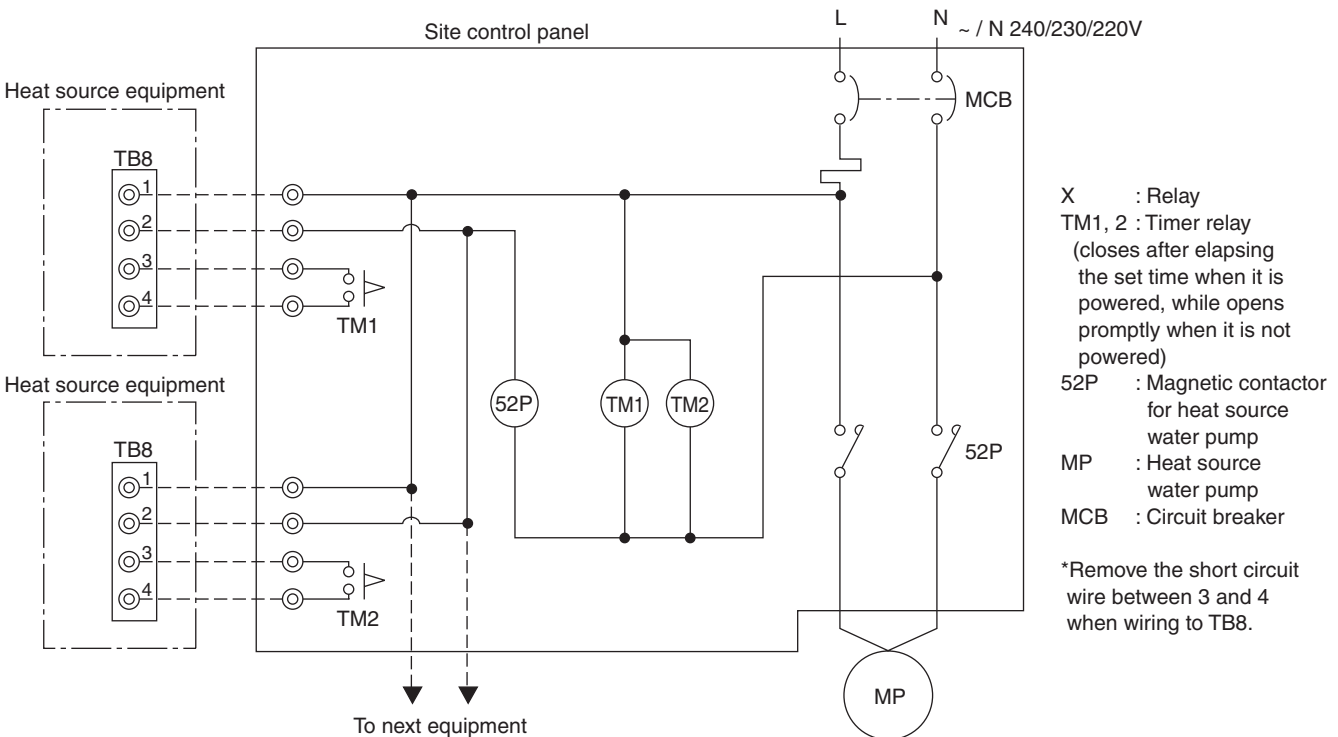



**Operation ON signal**

Terminal No.	TB8-1, 2
Output	Relay contacts output      Rated voltage : L1 - N : 220 ~ 240V Rated load : 1A
Operation	<ul style="list-style-type: none"> <li>• When Dip switch 2-7 is OFF The relay closes during compressor operation.</li> <li>• When DIP switch 2-7 is ON. The relay closes during reception of cooling or the heating operation signal from the controller. (Note : It is output even if the thermostat is OFF (when the compressor is stopped).)</li> </ul>

**Pump Interlock**

Terminal No.	TB8-3, 4
Input	Level signal
Operation	If the circuit between TB8-3 and TB8-4 is open, compressor operation is prohibited.

Y

R2

WY

WR2

S

OP

7-2.WATER PIPING WORK

Although the water piping for the CITY MULTI WR2 system does not differ from that for ordinary air conditioning systems, pay special attention to the items below in conducting the piping work.

1) Items to be observed on installation work

- In order to equalize piping resistance for each unit, adapt the reverse return system.
- Mount a joint and a valve onto the water outlet/inlet of the unit to allow for maintenance, inspection and replacement work. Be sure to mount a strainer at the water inlet piping of the unit. (The strainer is required at the circulation water inlet to protect the heat source unit.)
- \* The installation example of the heat source unit is shown right.
- Be sure to provide an air relief opening on the water piping properly, and purge air after feeding water to the piping system.
- Condensate will generate at the low temperature part inside the heat source equipment. Connect drain piping to the drain piping connection located at the bottom of the heat source equipment to discharge it outside the equipment.
- At the center of the header of the heat exchanger water inlet inside the unit, a plug for water discharge is being provided.  
Use it for maintenance work or the like.
- Mount a backflow prevention valve and a flexible joint for vibration control onto the pump.
- Provide a sleeve to the penetrating parts of the wall to prevent the piping.
- Fasten the piping with metal fitting, arrange the piping not to expose to cutting or bending force, and pay sufficient care for possible vibration.
- Be careful not to erroneously judge the position of the inlet and outlet of water.  
(Lower position : Inlet, Upper position : Outlet)

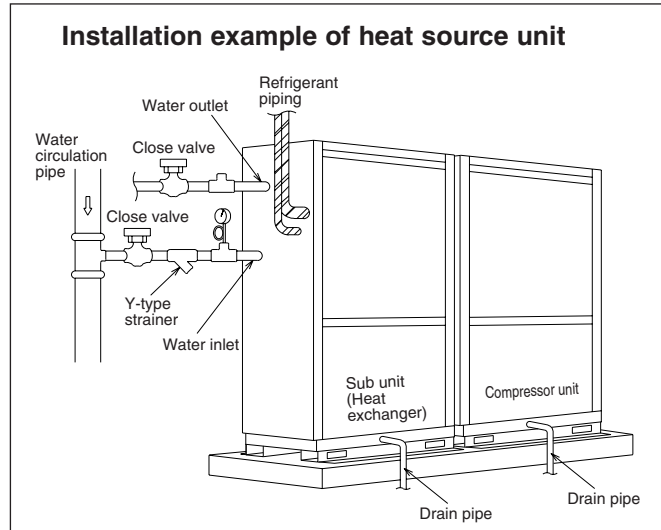

3) Water treatment and water quality control

For the circulation water cooling tower of the CITY MULTI WR2 system, employment of the closed type is recommended to keep water quality. However, in the case that an open type cooling tower is employed or the circulating water quality is inferior, scale will adhere onto the water heat exchanger leading to the decreased heat exchange capacity or the corrosion of the heat exchanger. Be sufficiently careful for water quality control and water treatment at the installation of the circulation water system.

- Removal of impurities inside piping  
Be careful not to allow impurities such as welding fragment, remaining sealing material and rust from mixing into the piping during installation work.
- Water treatment  
The water quality standards have been established by the industry (Japan Refrigeration, Air Conditioning Industry Association, in case of Japan) for water treatment to be applied.

2) Thermal insulation work

Thermal insulation or antisweating work is not required for the piping inside buildings in the case of the CITY MULTI WR2 system if the operating temperature range of circulation water stays within the temperature near the normal (summer : 30°C, winter : 20°C).

In case of the conditions below, however, thermal insulation is required.

- Use of well water for heat source water
- Outdoor piping portions
- Indoor piping portions where freezing may be caused in winter
- A place where vapor condensation may be generated on piping due to an increase in dry bulb temperature inside the ceiling caused by the entry of fresh outdoor air
- Drain piping portions

Items	Lower mid-range temperature water system		Tendency	
	Recirculating water [20<T<60°C]	Make-up water	Corrosive	Scale-forming
pH (25°C)	7.0 ~ 8.0	7.0 ~ 8.0	○	○
Electric conductivity (mS/m) (25°C) (μs/cm) (25°C)	30 or less [300 or less]	30 or less [300 or less]	○	○
Chloride ion (mg Cl/l)	50 or less	50 or less	○	
Sulfate ion (mg SO <sub>4</sub> <sup>2-</sup> /l)	50 or less	50 or less	○	
Acid consumption (pH4.8) (mg CaCO <sub>3</sub> /l)	50 or less	50 or less		○
Total hardness (mg CaCO <sub>3</sub> /l)	70 or less	70 or less		○
Calcium hardness (mg CaCO <sub>3</sub> /l)	50 or less	50 or less		○
Ionic silica (mg SiO <sub>2</sub> /l)	30 or less	30 or less		○
Iron (mg Fe/l)	1.0 or less	0.3 or less	○	○
Copper (mg Cu/l)	1.0 or less	0.1 or less	○	
Sulfide ion (mg S <sup>2-</sup> /l)	not to be detected	not to be detected	○	
Ammonium ion (mg NH <sub>4</sub> <sup>+</sup> /l)	0.3 or less	0.1 or less	○	
Residual chlorine (mg Cl/l)	0.25 or less	0.3 or less	○	
Free carbon dioxide (mg CO <sub>2</sub> /l)	0.4 or less	4.0 or less	○	
Ryzner stability index	-	-	○	○

Reference : Guideline of Water Quality for Refrigeration and Air Conditioning Equipment. (JRA GL02E-1994)

In order to keep the water quality within such standards, you are kindly requested to conduct bleeding-off by overflow and periodical water quality tests, and use inhibitors to suppress condensation or corrosion. Since piping may be corroded by some kinds of inhibitor, consult an appropriate water treatment expert for proper water treatment.

### (4) Pump interlock

Operating the heat source unit without circulation water inside the water piping can cause a trouble. Be sure to provide interlocking for the unit operation and water circuit. Since the terminal block is being provided inside the unit, use it as required.

Y

R2

WY

WR2

S

OP

Y

R2

WY

**WR2**

S

OP