

# TECHNICAL & SERVICE MANUAL

## Series PMFY Ceiling Cassettes R410A / R407C / R22

Indoor unit  
[Model names]

PMFY-P20VBM-E

PMFY-P25VBM-E

PMFY-P32VBM-E

PMFY-P40VBM-E

[Service Ref.]

**PMFY-P20VBM-E**

**PMFY-P25VBM-E**

**PMFY-P32VBM-E**

**PMFY-P40VBM-E**

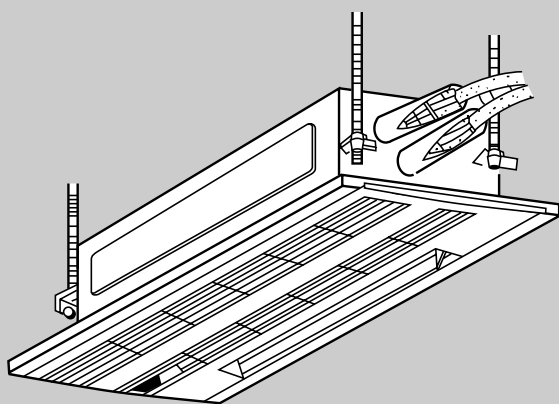

INDOOR UNIT

### CONTENTS

1. SAFETY PRECAUTION .....	2
2. PART NAMES AND FUNCTIONS .....	6
3. SPECIFICATION .....	8
4. OUTLINES AND DIMENSIONS.....	12
5. WIRING DIAGRAM.....	13
6. REFRIGERANT SYSTEM DIAGRAM ...	14
7. TROUBLE SHOOTING.....	15
8. DISASSEMBLY PROCEDURE.....	22
9. PARTS LIST.....	25

# 1

# SAFETY PRECAUTION

## CAUTIONS RELATED TO NEW REFRIGERANT

### Caution for units utilizing refrigerant R407C

#### Do not use the existing refrigerant piping.

The old refrigerant and lubricant in the existing piping contains a large amount of chlorine which may cause the lubricant deterioration of the new unit.

#### Use liquid refrigerant to seal the system.

If gas refrigerant is used to seal the system, the composition of the refrigerant in the cylinder will change and performance may drop.

#### Use "low residual oil piping"

If there is a large amount of residual oil (hydraulic oil, etc.) inside the piping and joints, deterioration of the lubricant will result.

#### Do not use a refrigerant other than R407C.

If another refrigerant (R22, etc.) is used, the chlorine in the refrigerant may cause the lubricant deterioration.

#### Store the piping to be used during installation indoors with keep both ends sealed until just before brazing. (Store elbows and other joints in a plastic bag.)

If dust, dirt, or water enters the refrigerant cycle, deterioration of the oil and compressor trouble may result.

#### Use a vacuum pump with a reverse flow check valve.

The vacuum pump oil may flow back into the refrigerant cycle and cause the lubricant deterioration.

#### Use ESTR , ETHER or HAB as the lubricant to coat flares and flange connection parts.

If large amount of mineral oil enter, that can cause deterioration of refrigerant oil etc.

#### Ventilate the room if refrigerant leaks during operation. If refrigerant comes into contact with a flame, poisonous gases will be released.

## [1] Cautions for service

- After recovering the all refrigerant in the unit, proceed to working.
- Do not release refrigerant in the air.
- After completing the repair service, recharge the cycle with the specified amount of liquid refrigerant.

## [2] Refrigerant recharging

### (1) Refrigerant recharging process

#### ① Direct charging from the cylinder.

- R407C cylinder are available on the market has a syphon pipe.
- Leave the syphon pipe cylinder standing and recharge it.  
(By liquid refrigerant)

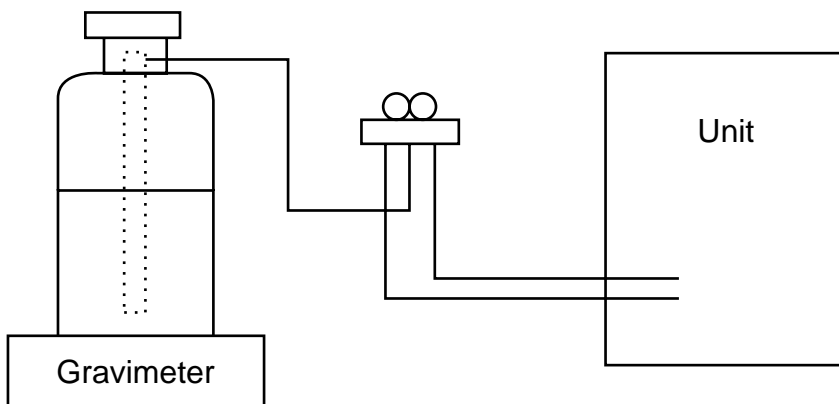

### (2) Recharge in refrigerant leakage case

- After recovering the all refrigerant in the unit, proceed to working.
- Do not release the refrigerant in the air.
- After completing the repair service, recharge the cycle with the specified amount of liquid refrigerant.

### [3] Service tools

Use the below service tools as exclusive tools for R407C refrigerant.

No.	Tool name	Specifications
①	Gauge manifold	·Only for R407C.
		·Use the existing fitting SPECIFICATIONS. (UNF7/16)
		·Use high-tension side pressure of 3.43MPa-G or over.
②	Charge hose	·Only for R407C.
		·Use pressure performance of 5.10MPa-G or over.
③	Electronic scale	
④	Gas leak detector	·Use the detector for R134a or R407C.
⑤	Adapter for reverse flow check.	·Attach on vacuum pump.
⑥	Refrigerant charge base.	
⑦	Refrigerant cylinder.	·For R407C      ·Top of cylinder (Brown)
		·Cylinder with syphon
⑧	Refrigerant recovery equipment.	

## Cautions for units utilizing refrigerant R410A

### Do not use the existing refrigerant piping.

The old refrigerant and lubricant in the existing piping contains a large amount of chlorine which may cause the lubricant deterioration of the new unit.

### Use "low residual oil piping"

If there is a large amount of residual oil (hydraulic oil, etc.) inside the piping and joints, deterioration of the lubricant will result.

### Store the piping to be used during installation indoors and keep both ends of the piping sealed until just before brazing. (Leave elbow joints, etc. in their packaging.)

If dirt, dust or moisture enter into refrigerant cycle, that can cause deterioration of refrigerant oil or malfunction of compressor.

### Use ester oil, ether oil or alkylbenzene oil (small amount) as the refrigerant oil applied to flares and flange connections.

If large amount of mineral oil enter, that can cause deterioration of refrigerant oil etc.

### Charge refrigerant from liquid phase of gas cylinder.

If the refrigerant is charged from gas phase, composition change may occur in refrigerant and the efficiency will be lowered.

### Do not use refrigerant other than R410A.

If other refrigerant (R22 etc.) is used, chlorine in refrigerant can cause deterioration of refrigerant oil etc.

### Use a vacuum pump with a reverse flow check valve.

Vacuum pump oil may flow back into refrigerant cycle and that can cause deterioration of refrigerant oil etc.

### Use the following tools specifically designed for use with R410A refrigerant.

The following tools are necessary to use R410A refrigerant.

Tools for R410A	
Gauge manifold	Flare tool
Charge hose	Size adjustment gauge
Gas leak detector	Vacuum pump adaptor
Torque wrench	Electronic refrigerant charging scale

### Keep the tools with care.

If dirt, dust or moisture enter into refrigerant cycle, that can cause deterioration of refrigerant oil or malfunction of compressor.

### Do not use a charging cylinder.

If a charging cylinder is used, the composition of refrigerant will change and the efficiency will be lowered.

### Ventilate the room if refrigerant leaks during operation. If refrigerant comes into contact with a flame, poisonous gases will be released.

### [1] Cautions for service

- (1) Perform service after collecting the refrigerant left in unit completely.
- (2) Do not release refrigerant in the air.
- (3) After completing service, charge the cycle with specified amount of refrigerant.
- (4) When performing service, install a filter drier simultaneously.  
Be sure to use a filter drier for new refrigerant.

### [2] Additional refrigerant charge

#### When charging directly from cylinder

- Check that cylinder for R410A on the market is syphon type.
- Charging should be performed with the cylinder of syphon stood vertically. (Refrigerant is charged from liquid phase.)

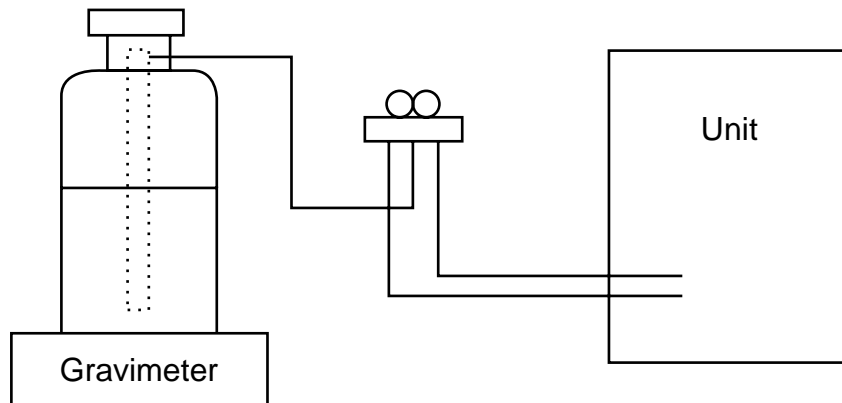

### [3] Service tools

Use the below service tools as exclusive tools for R410A refrigerant.

No.		Specifications
①	Gauge manifold	·Only for R410A
		·Use the existing fitting specifications. (UNF1/2)
		·Use high-tension side pressure of 5.3MPa-G or over.
②	Charge hose	·Only for R410A
		·Use pressure performance of 5.09MPa-G or over.
③	Electronic scale	—
④	Gas leak detector	·Use the detector for R134a, R407C or R410A.
⑤	Adaptor for reverse flow check	·Attach on vacuum pump.
⑥	Refrigerant charge base	—
⑦	Refrigerant cylinder	·Only for R410A
		Top of cylinder (Pink) Cylinder with syphon
⑧	Refrigerant recovery equipment	—

## 2

# PART NAMES AND FUNCTIONS

### ● Indoor Unit

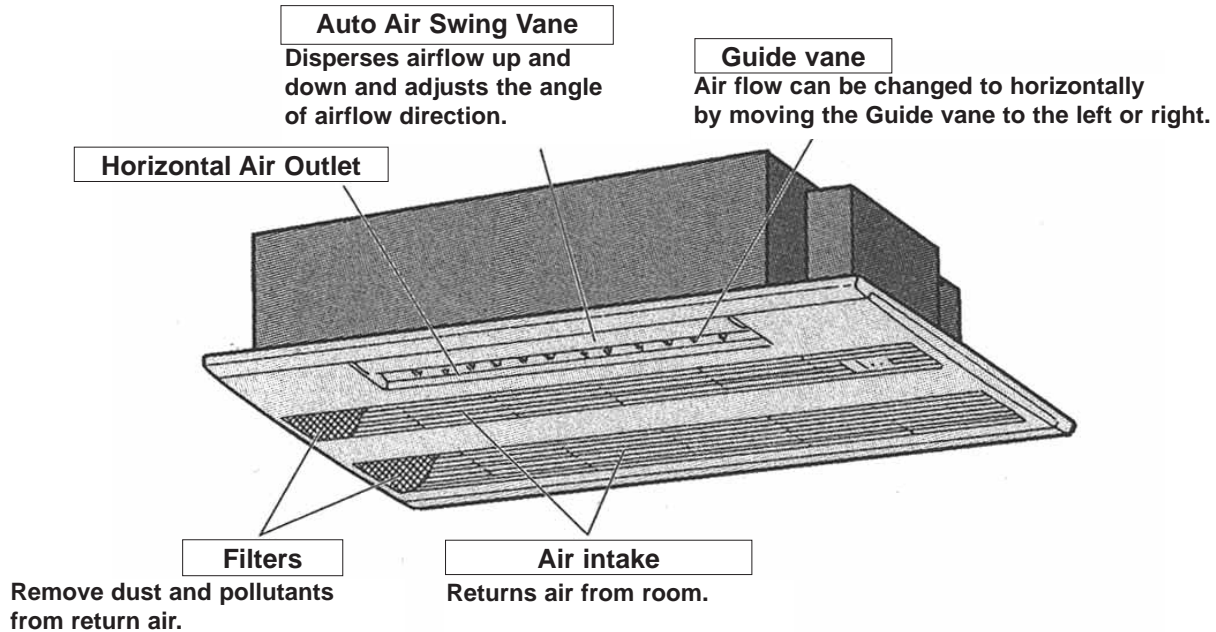

### ● Remote controller

#### [PAR-20MAA]

- Once the controls are set, the same operation mode can be repeated by simply pressing the ON/OFF button.

### ● Operation buttons

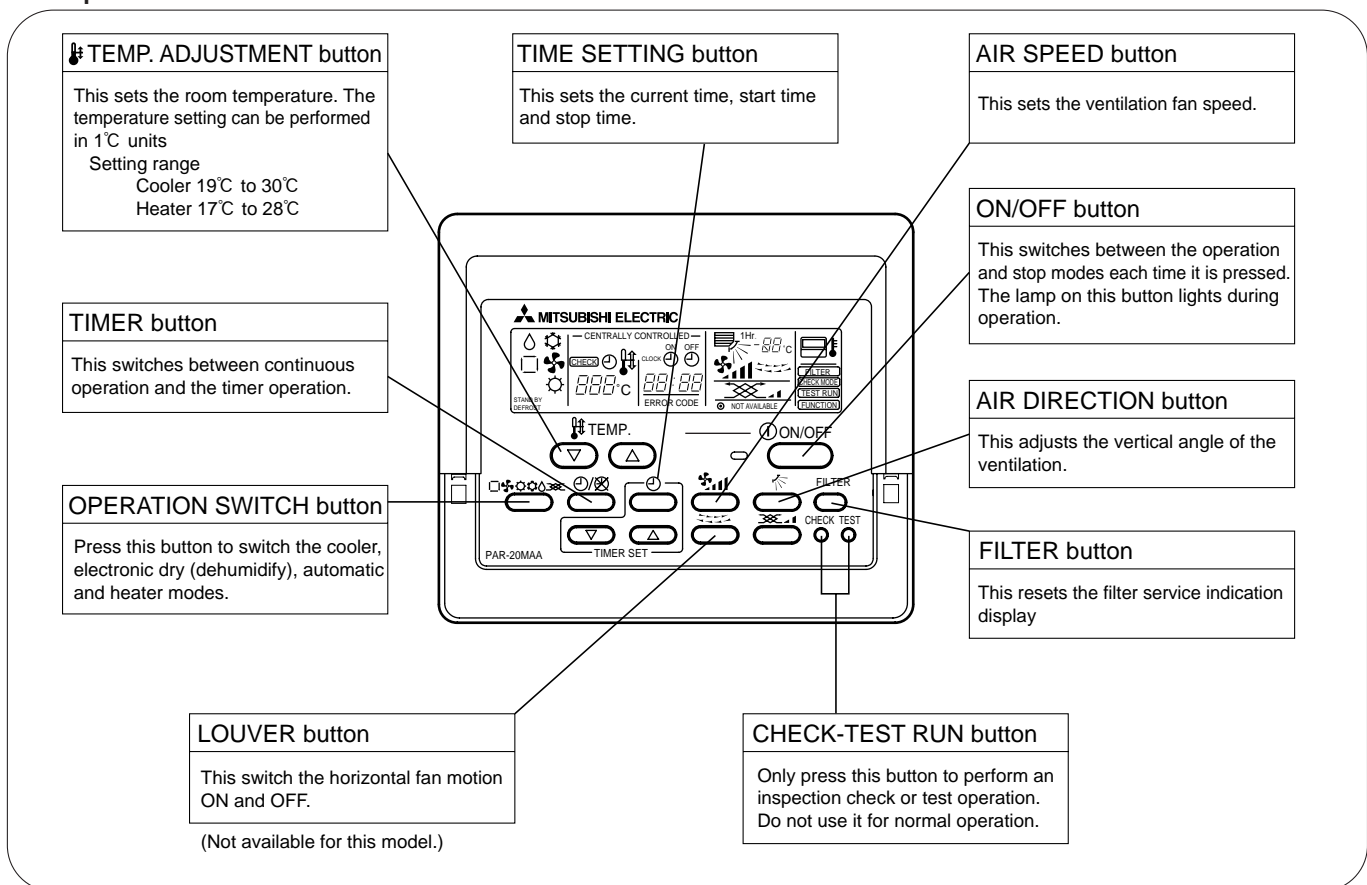

## ● Display

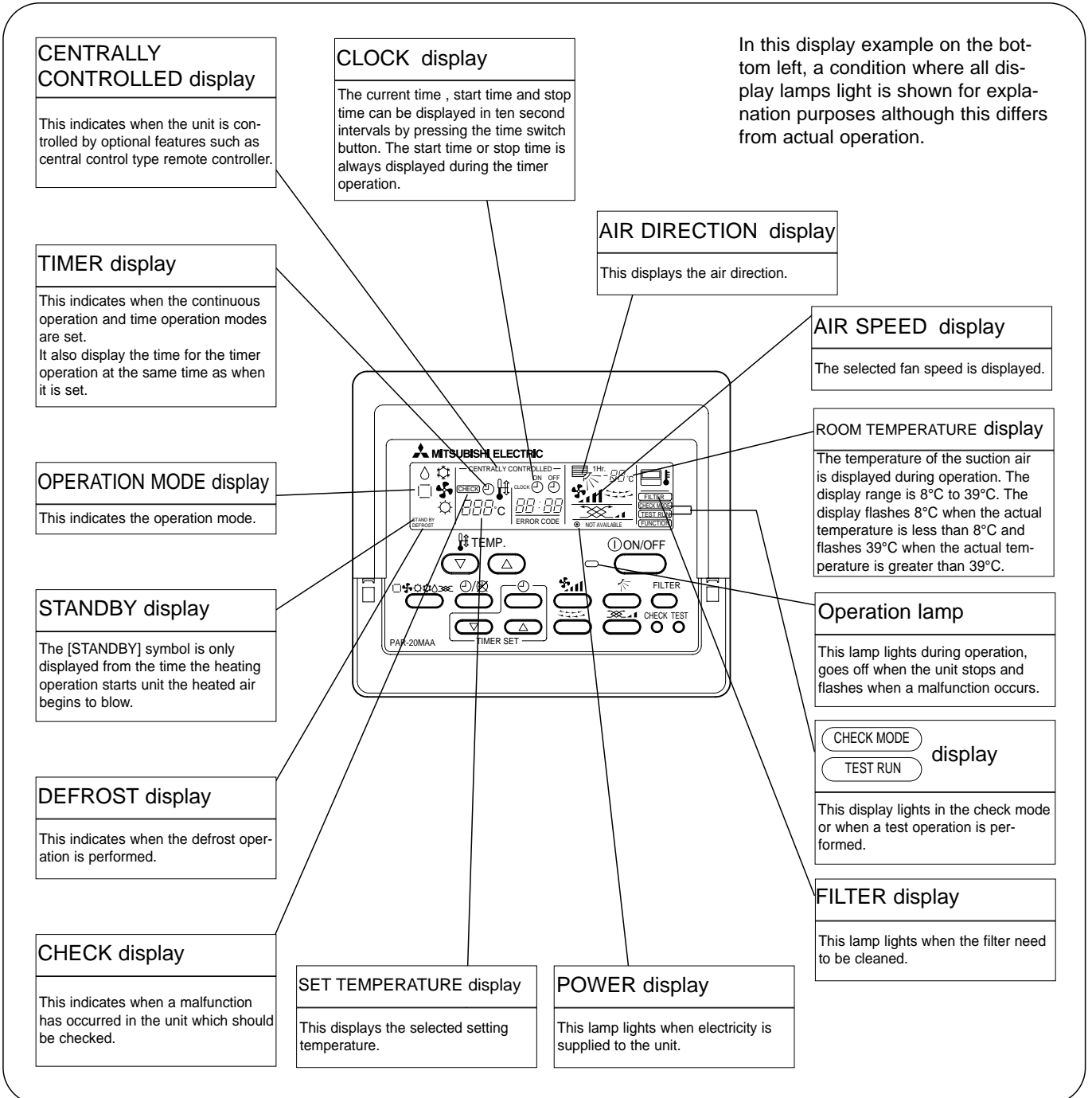

## Caution

- Only the Power display lights when the unit is stopped but power is supplied to the unit.
- When the central control remote control unit, which is sold separately, is used the ON-OFF button, operation switch button and TEMP. adjustment button do not operate.
- "NOT AVAILABLE" is displayed when the Air speed button are pressed. This indicates that this room unit is not equipped with the fan direction adjustment function and the louver function.
- When power is turned ON for the first time, it is normal that "H0" is displayed on the room temperature indication (For max. 2minutes). Please wait until this "H0" indication disappear then start the operation.

## 3-1. Specification

Item		PMFY-P20VBM-E	PMFY-P25VBM-E	PMFY-P32VBM-E	PMFY-P40VBM-E		
Power	V•Hz	Single phase 220V-230V-240V 50Hz / 220V 60Hz					
Cooling capacity	kW	2.2	2.8	3.6	4.5		
Heating capacity	kW	2.5	3.2	4.0	5.0		
Electric characteristic	Input	Cooling	kW	0.042	0.044	0.044	0.054
		Heating	kW	0.042	0.044	0.044	0.054
	Current	Cooling	A	0.20	0.21	0.21	0.26
		Heating	A	0.20	0.21	0.21	0.26
Exterior (munsell symbol)	—	Unit : Galvanized sheets · Standard grills : ABS resin acrylic coating Munsell<0.98Y 8.99/0.63>					
Dimensions	Height	mm	230<30>				
	Width	mm	812<1,000>				
	Depth	mm	395<470>				
Heat exchanger	—	Cross fin					
Fan	Fan X No	—	Line flow fan X 1				
	Air flow ※3	m <sup>3</sup> /min	8.7-8.0-7.2-6.5	9.3-8.6-8.0-7.3	10.7-9.7-8.7-7.7		
	External static pressure	Pa	0				
	Fan motor output	kW	0.028				
Insulator	—	Polyethylene sheet					
Air filter	—	PP honey comb fabric					
Pipe dimensions	Gas side	φmm(in.)	12.7(1/2")				
	Liquid side	φmm(in.)	6.35(1/4")				
Unit drain pipe size	φmm	I.D.26 (PVC pipe VP-20 connectable)					
Noise level ※3	dB	35-33-30-27	37-36-34-32	39-37-35-33			
Product weight	kg	14<3.0>					

- Note 1. Rating conditions (JIS B 8615-1)  
Cooling: Indoor: D.B. 27°C W.B. 19°C  
outdoor: D.B. 35°C  
Heating: Indoor: D.B. 20°C  
outdoor: D.B. 7°C W.B. 6°C

Note 2. The number indicated in < > is just for the grille.

- ※ 3. Air flow and the noise level are indicated as High – Middium1 – Middium2 – Low.



### 3-2. Electrical parts specifications

Model Parts name	Symbol	PMFY-P20VBM-E	PMFY-P25VBM-E	PMFY-P32VBM-E	PMFY-P40VBM-E
Room temperature thermistor	TH21	Resistance 0°C/15kΩ, 10°C/9.6kΩ, 20°C/6.3kΩ, 25°C/5.4kΩ, 30°C/4.3kΩ, 40°C/3.0kΩ			
Liquid pipe thermistor	TH22	Resistance 0°C/15kΩ, 10°C/9.6kΩ, 20°C/6.3kΩ, 25°C/5.4kΩ, 30°C/4.3kΩ, 40°C/3.0kΩ			
Gas pipe thermistor	TH23	Resistance 0°C/15kΩ, 10°C/9.6kΩ, 20°C/6.3kΩ, 25°C/5.4kΩ, 30°C/4.3kΩ, 40°C/3.0kΩ			
Fuse (Indoor controller board)	FUSE	250V 6.3A			
Fan motor	MF	DC Brushless Motor 8-pole OUTPUT 28W PN0H28-MA			
Vane motor	MV	MSFJC 20M23 12V/380Ω			
Drain-up mechanism	DP	PJV-1046 220-240V 50/60Hz			
Drain sensor	DS	Thermistor resistance 0°C/6kΩ, 10°C/3.9kΩ, 20°C/2.6kΩ, 25°C/2.2kΩ, 30°C/1.8kΩ, 40°C/1.3kΩ			
Linear expansion valve	LEV	DC12V Stepping motor drive port (0~2000pulse)			
Power supply terminal block	TB2	(L, N, ⊕) 330V 30A			
Transmission terminal block	TB5	(M1, M2, S) 250V 20A			
MA-remote controller terminal block	TB15	(1,2) 250V 10A			

### 3-3. Air capacity taken from outside

PMFY-P-VBM-A series enables to take fresh air from outside.  
 When taking fresh air, the duct fan is used to.  
 The air capacity should be 20% or less of the air flow SPEC(Hi).

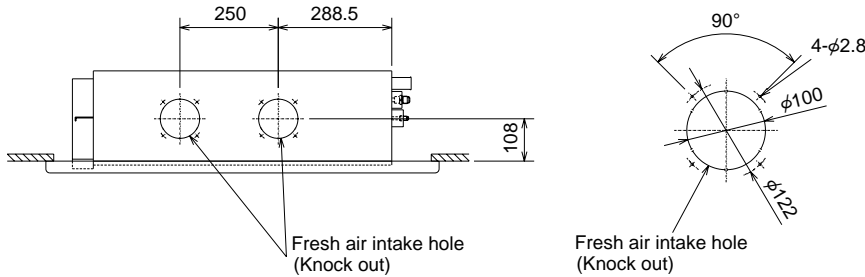

Service Ref.	Air flow (Hi)	Air capacity from outside
PMFY-P20VBM-E	8.7m <sup>3</sup> /min	Max 1.74m <sup>3</sup> /min
PMFY-P25VBM-E	9.3m <sup>3</sup> /min	Max 1.86m <sup>3</sup> /min
PMFY-P32VBM-E	9.3m <sup>3</sup> /min	Max 1.86m <sup>3</sup> /min
PMFY-P40VBM-E	10.7m <sup>3</sup> /min	Max 2.14m <sup>3</sup> /min

#### Interlocking operation method with duct fan (Booster fan)

- Whenever the indoor unit is operating, the duct fan also operates.
- (1) Connect the optional multiple remote controller adapter (PAC-SA88HA-E) to the connector CN51 on the indoor controller board.
- (2) Drive the relay after connecting the 12V DC relay between the Yellow and Orange connector lines.
- (\*) Use a relay under 1W.
- MB: Electromagnetic switch power relay for duct fan.
- X: Auxiliary relay (12V DC LY-1F)

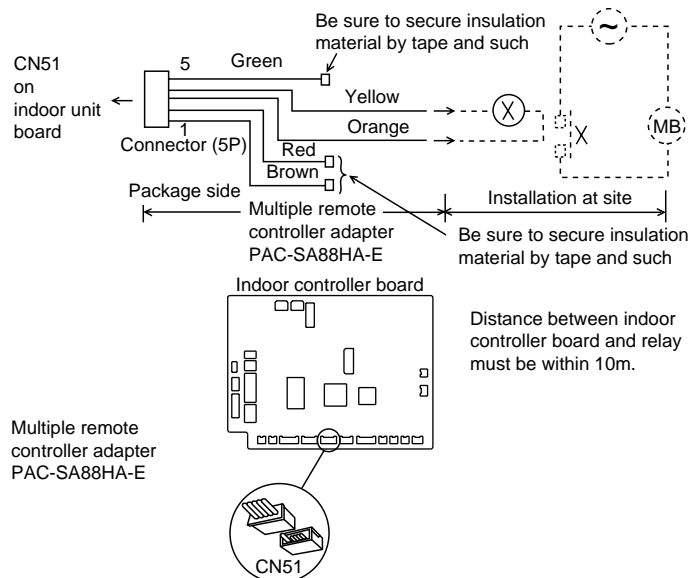

#### How to read curves

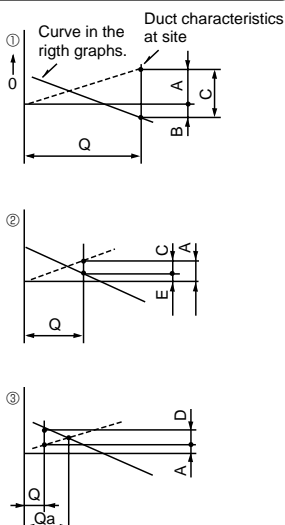

- Q...Planned amount of fresh air intake <m<sup>3</sup>/min>
- A...Static pressure loss of fresh air intake duct system with air flow amount Q <Pa>
- B...Forced static pressure at air conditioner inlet with air flow amount Q <Pa>
- C...Static pressure of booster fan with air flow amount Q <Pa>
- D...Static pressure loss increase amount of fresh air intake duct system for air flow amount Q <Pa>
- E...Static pressure of indoor unit with air flow amount Q <Pa>
- Qa...Estimated amount of fresh air intake with out D <m<sup>3</sup>/min>

Characteristic diagram of fresh air taken capacity

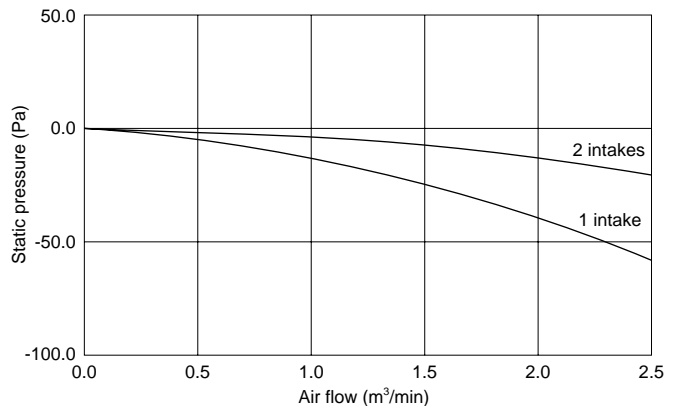

### 3-4. NOISE CRITERION CURVES

**PMFY-P20VBM-E**

NOTCH	SPL(dB)	LINE
Hi	35	○—○
Mi1	33	△—△
Mi2	30	▲—▲
Lo	27	●—●

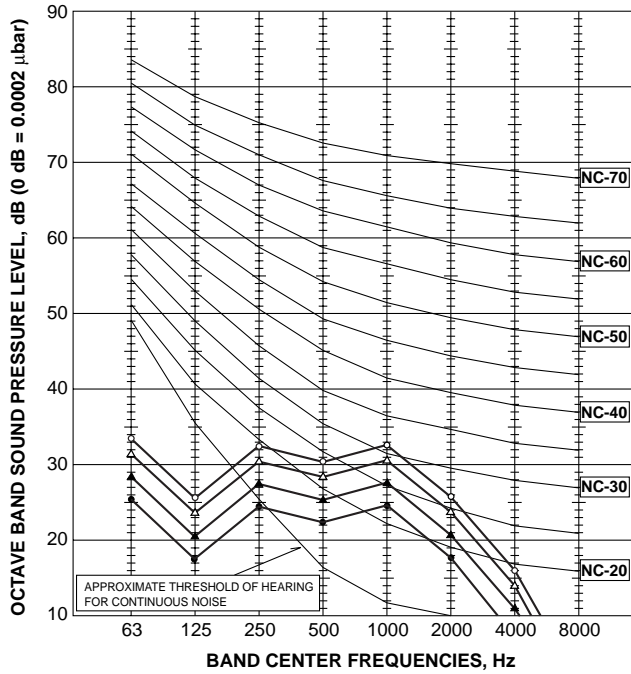

**PMFY-P25VBM-E**  
**PMFY-P32VBM-E**

NOTCH	SPL(dB)	LINE
Hi	37	○—○
Mi1	36	△—△
Mi2	34	▲—▲
Lo	32	●—●

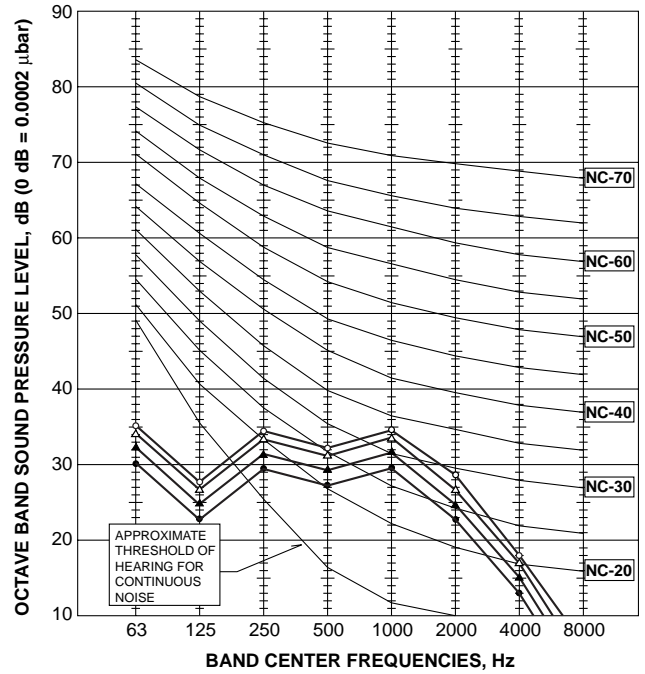

**PMFY-P40VBM-E**

NOTCH	SPL(dB)	LINE
Hi	39	○—○
Mi1	37	△—△
Mi2	35	▲—▲
Lo	33	●—●

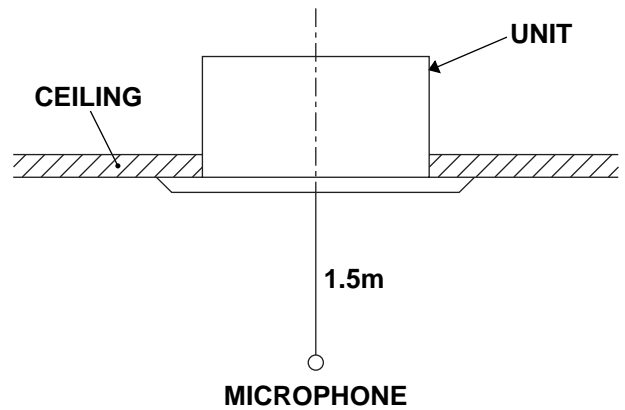
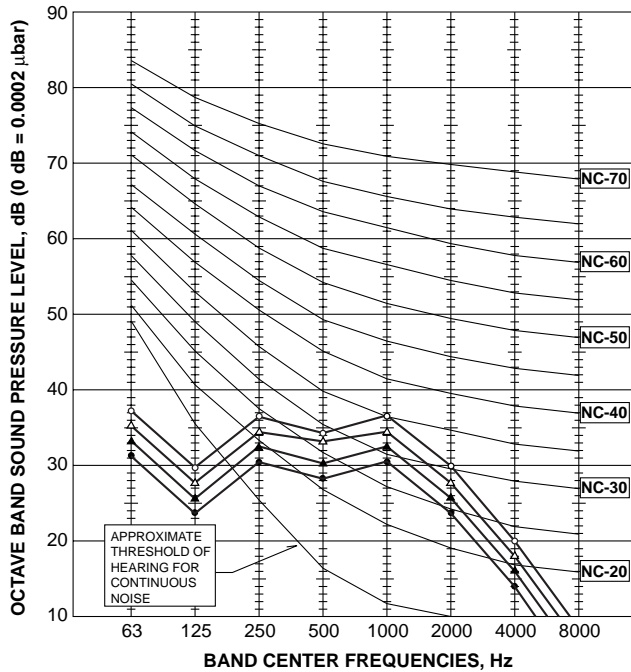

PMFY-P20VBM-E  
 PMFY-P20VBM-E  
 PMFY-P32VBM-E  
 PMFY-P40VBM-E

Unit : mm

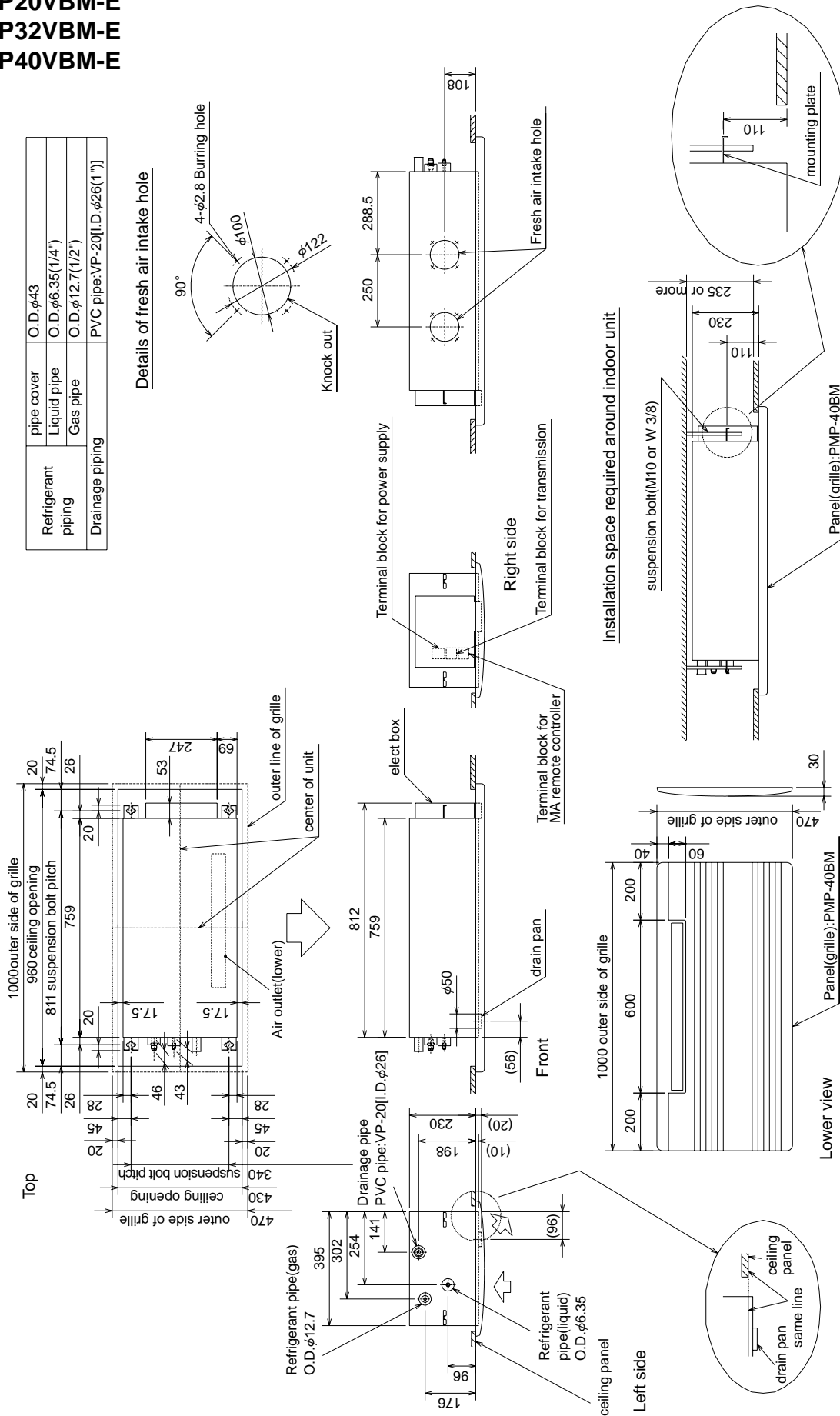

PMFY-P20VBM-E  
 PMFY-P25VBM-E  
 PMFY-P32VBM-E  
 PMFY-P40VBM-E

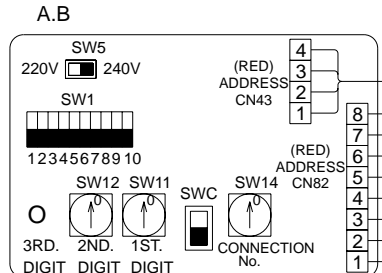
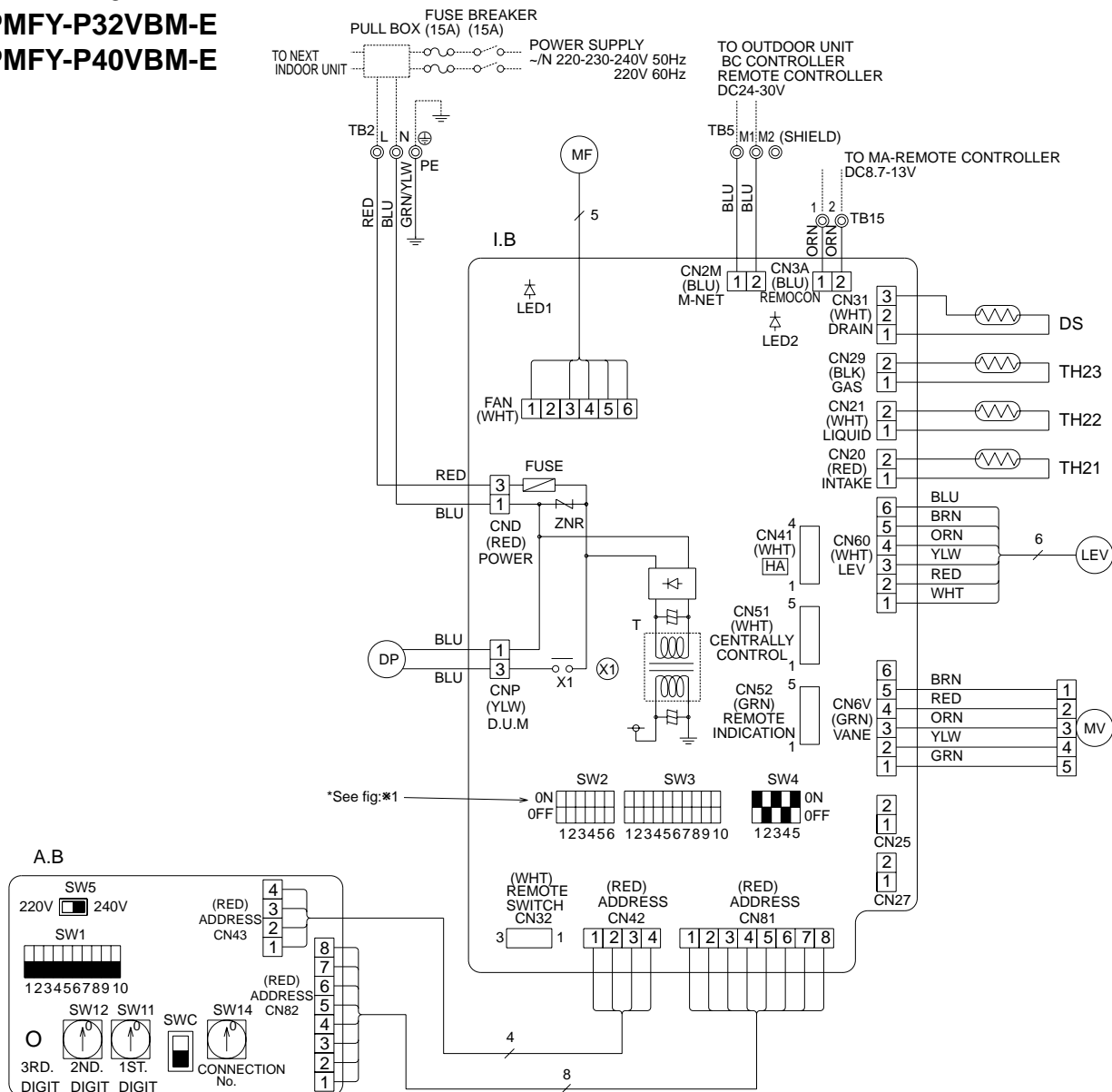

[ LEGEND ]

SYMBOL	NAME	SYMBOL	NAME
I.B	INDOOR CONTROLLER BOARD	MF	FAN MOTOR
CN25	CONNECTOR/HUMIDIFIER	MV	VANE MOTOR
CN27	DAMPEN	DP	DRAIN WATER LIFTING-UP MACH.
CN32	REMOTE SWITCH	DS	DRAIN SENSOR
CN41	HA TERMINAL-A	TB2	TERMINAL
CN41	CENTRALLY CONTROL	TB5	BLOCK
CN52	REMOTE INDICATION	TB15	TRANSMISSION
SW2	SWITCH	TH21	THERMISTOR
SW3	CAPACITY CODE	TH22	PIPE TEMPERATURE DETECTION (0°C/15kΩ, 25°C/5.4kΩ)
SW4	MODE SELECTION	TH23	PIPE TEMPERATURE DETECTION/LIQUID (0°C/15kΩ, 25°C/5.4kΩ)
ZNR	VARIATOR	TH21	PIPE TEMPERATURE DETECTION/GAS (0°C/15kΩ, 25°C/5.4kΩ)
FUSE	FUSE(6.3A/250V)	LEV	LINEAR EXPANSION VALVE
X1	AUX.RELAY		
T	TRANSFORMER		
LED1	POWER SUPPLY(I.B)		
LED2	POWER SUPPLY(I.B)		
A.B	CIRCUIT BOARD		
SW1	SWITCH		
SW5	MODE SELECTION		
SW11	VOLTAGE SELECTION		
SW12	ADDRESS SETTING 1ST DIGIT		
SW14	ADDRESS SETTING 2ND DIGIT		
	CONNECTION NO.		

< \*1 >

MODELS	SW2	SW3
P20VBM	ON OFF 123456	ON OFF 12345678910
P25VBM	ON OFF 123456	ON OFF 12345678910
P32VBM	ON OFF 123456	ON OFF 12345678910
P40VBM	ON OFF 123456	ON OFF 12345678910

- NOTES:
- At servicing for outdoor unit, always follow the wiring diagram of outdoor unit.
  - In case of using MA-Remote controller, please connect to TB15. (Remote controller wire is non-polar.)
  - In case of using M-NET, please connect to TB5. (Transmission line in non-polar.)
  - Symbol [S] of TB5 is the shield wire connection.
  - Symbols used in wiring diagram above are,
    - ⊙:terminal block, □□□:connector.
  - The setting of the SW2 dip switches differs in the capacity. For the detail, refer to the table below.
  - Please set the switch SW5 according to the power supply voltage. Set SW5 to 240V side when the power supply is 230 and 240 volts. When the power supply is 220 volts, set SW5 to 220V side.

LED on indoor board for service

Mark	Meaning	Function
LED1	Main power supply	Main power supply(Indoor unit:220-240V) power on → lamp is lit
LED2	Power supply for MA-Remote controller	Power supply for MA-Remote controller on → lamp is lit

6

REFRIGERANT SYSTEM DIAGRAM

PMFY-P20VBM-E PMFY-P25VBM-E PMFY-P32VBM-E PMFY-P40VBM-E

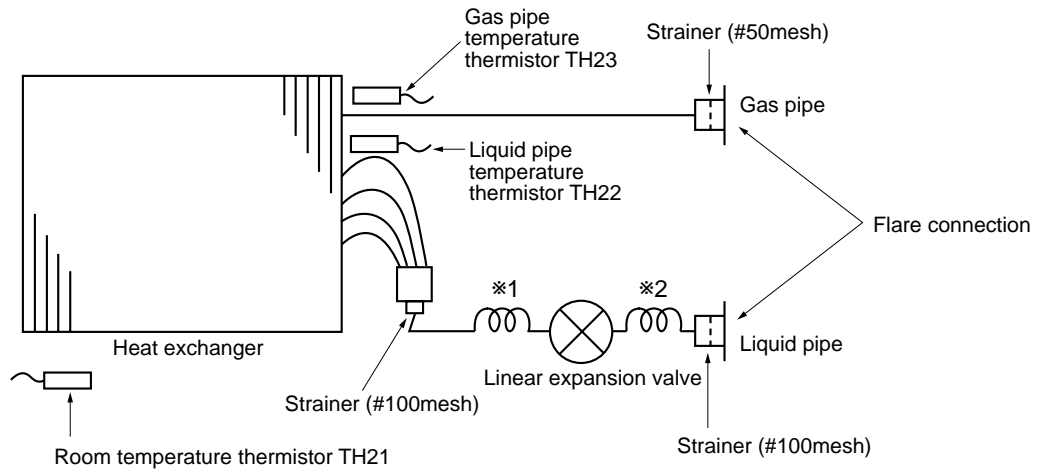

Service Ref.	PMFY-P20, P25, P32, P40VBM-E
Item	
Gas pipe	$\phi 12.7(1/2")$
Liquid pipe	$\phi 6.35(1/4")$

	PMFY-P20, P25VBM-E	PMFY-P32, P25VBM-E
Capillary tube *1	O.D. $\phi 4.6 \times$ I.D. $\phi 3.4 \times l 200$	O.D. $\phi 3.6 \times$ I.D. $\phi 2.4 \times l 200$
Capillary tube *2	O.D. $\phi 3.6 \times$ I.D. $\phi 2.4 \times l 80$	

# 7

# TROUBLE SHOOTING

## 7-1. How to check the parts

### PMFY-P20VBM-E PMFY-P25VBM-E PMFY-P32VBM-E PMFY-P40VBM-E

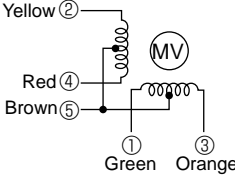
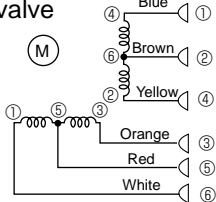
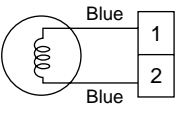
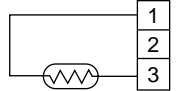
Parts name	Check points														
Room temperature thermistor (TH21) Liquid pipe temperature thermistor (TH22) Gas pipe temperature thermistor (TH23)	Disconnect the connector then measure the resistance using a tester. (Surrounding temperature 10°C ~30°C) <table border="1" style="margin-left: 20px;"> <thead> <tr> <th>Normal</th> <th>Abnormal</th> </tr> </thead> <tbody> <tr> <td>4.3kΩ~9.6kΩ</td> <td>Open or short</td> </tr> </tbody> </table> Refer to the next page for the details.	Normal	Abnormal	4.3kΩ~9.6kΩ	Open or short										
Normal	Abnormal														
4.3kΩ~9.6kΩ	Open or short														
Vane motor 	Measure the resistance between the terminals using a tester. (Surrounding temperature 20°C ~30°C) <table border="1" style="margin-left: 20px;"> <thead> <tr> <th>Connector</th> <th>Normal</th> <th>Abnormal</th> </tr> </thead> <tbody> <tr> <td>Brown — Yellow</td> <td rowspan="4">380Ω ±7%</td> <td rowspan="4">Open or short</td> </tr> <tr> <td>Brown — Red</td> </tr> <tr> <td>Brown — Orange</td> </tr> <tr> <td>Brown — Green</td> </tr> </tbody> </table>	Connector	Normal	Abnormal	Brown — Yellow	380Ω ±7%	Open or short	Brown — Red	Brown — Orange	Brown — Green					
Connector	Normal	Abnormal													
Brown — Yellow	380Ω ±7%	Open or short													
Brown — Red															
Brown — Orange															
Brown — Green															
Linear expansion valve 	Disconnect the connector then measure the resistance valve using a tester. Refer to the next page for a detail. <table border="1" style="margin-left: 20px;"> <thead> <tr> <th colspan="4">Normal</th> <th>Abnormal</th> </tr> </thead> <tbody> <tr> <td>(1)-(5) White-Red</td> <td>(2)-(6) Yellow-Blown</td> <td>(3)-(5) Orange-Red</td> <td>(4)-(6) Blue-Brown</td> <td rowspan="2">Open or short</td> </tr> <tr> <td colspan="4" style="text-align: center;">150kΩ ±10%</td> </tr> </tbody> </table> Refer to the next page for the details.	Normal				Abnormal	(1)-(5) White-Red	(2)-(6) Yellow-Blown	(3)-(5) Orange-Red	(4)-(6) Blue-Brown	Open or short	150kΩ ±10%			
Normal				Abnormal											
(1)-(5) White-Red	(2)-(6) Yellow-Blown	(3)-(5) Orange-Red	(4)-(6) Blue-Brown	Open or short											
150kΩ ±10%															
Drain-up mechanism 	Measure the resistance between the terminals using a tester. (Surrounding temperature 20°C) <table border="1" style="margin-left: 20px;"> <thead> <tr> <th>Normal</th> <th>Abnormal</th> </tr> </thead> <tbody> <tr> <td>400Ω~480Ω</td> <td>Open or short</td> </tr> </tbody> </table>	Normal	Abnormal	400Ω~480Ω	Open or short										
Normal	Abnormal														
400Ω~480Ω	Open or short														
Drain sensor 	Measure the resistance after 3 minutes have passed since the power supply was intercepted. (Surrounding temperature 0°C ~60°C) <table border="1" style="margin-left: 20px;"> <thead> <tr> <th>Normal</th> <th>Abnormal</th> </tr> </thead> <tbody> <tr> <td>0.6kΩ~6.0kΩ</td> <td>Open or short</td> </tr> </tbody> </table> Refer to the next page for the details.	Normal	Abnormal	0.6kΩ~6.0kΩ	Open or short										
Normal	Abnormal														
0.6kΩ~6.0kΩ	Open or short														

### <Thermistor Characteristic graph>

Thermistor for lower temperature

Room temperature thermistor (TH21)  
Liquid pipe temperature thermistor (TH22)  
Gas pipe temperature thermistor (TH23)

Thermistor  $R_0 = 15k\Omega \pm 3\%$   
Fixed number of  $B = 3480K \pm 2\%$

$$R_t = 15 \exp \left\{ 3480 \left( \frac{1}{273+t} - \frac{1}{273} \right) \right\}$$

0°C	: 15kΩ
10°C	: 9.6kΩ
20°C	: 6.3kΩ
25°C	: 5.4kΩ
30°C	: 4.3kΩ
40°C	: 3.0kΩ

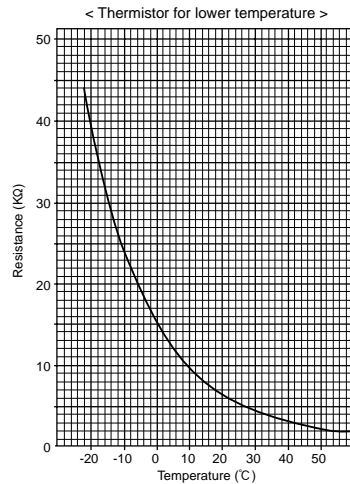

Thermistor for lower temperature

Drain sensor (DS)

Thermistor  $R_0 = 6.0k\Omega \pm 3\%$   
Fixed number of  $B = 3390K \pm 2\%$

$$R_t = 6 \exp \left\{ 3390 \left( \frac{1}{273+t} - \frac{1}{273} \right) \right\}$$

0°C	: 6 kΩ
10°C	: 3.9kΩ
20°C	: 2.6kΩ
25°C	: 2.2kΩ
30°C	: 1.8kΩ
40°C	: 1.3kΩ

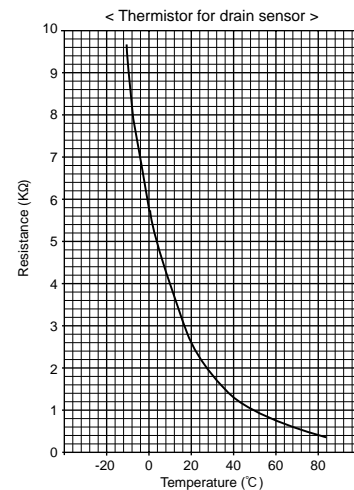

### Linear expansion valve

#### ① Operation summary of the linear expansion valve.

- Linear expansion valve open/close through stepping motor after receiving the pulse signal from the indoor controller board.
- Valve position can be changed in proportion to the number of pulse signal.

<Connection between the indoor controller board and the linear expansion valve>

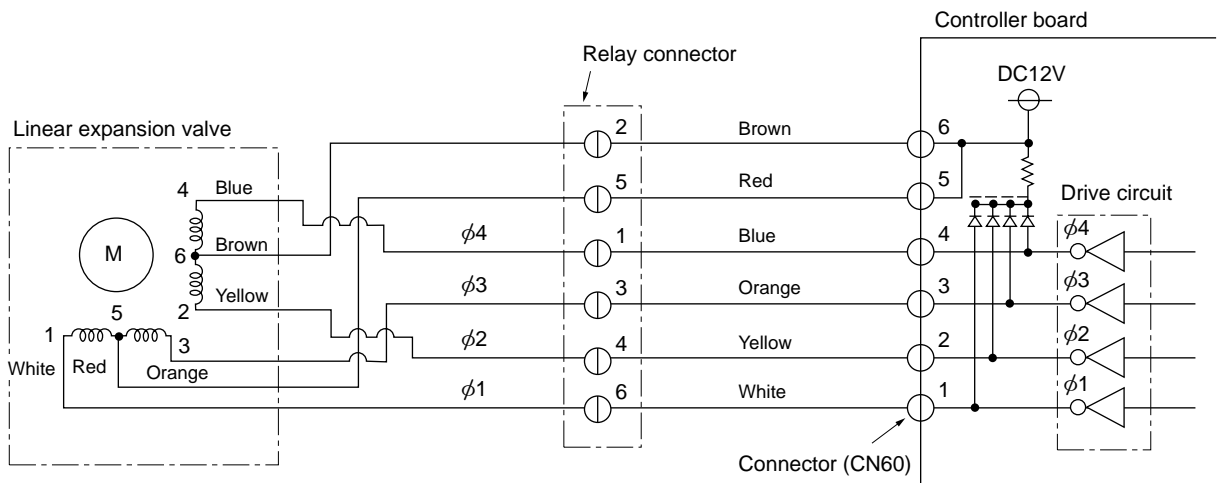

Note : Since the number of the connector at the controller board side and the relay connector are different, follow the color of the lead wire.



### <Output pulse signal and the valve operation>

Output (Phase)	Output			
	1	2	3	4
φ1	ON	OFF	OFF	ON
φ2	ON	ON	OFF	OFF
φ3	OFF	ON	ON	OFF
φ4	OFF	OFF	ON	ON

Closing a valve : 1 → 2 → 3 → 4 → 1  
 Opening a valve : 4 → 3 → 2 → 1 → 4

The output pulse shifts in above order.

- \* 1. When linear expansion valve operation stops, all output phase become OFF.
- 2. At phase interruption or when phase does not shift in order, motor does not rotate smoothly and motor will locks and vibrates.

#### ② Linear expansion valve operation

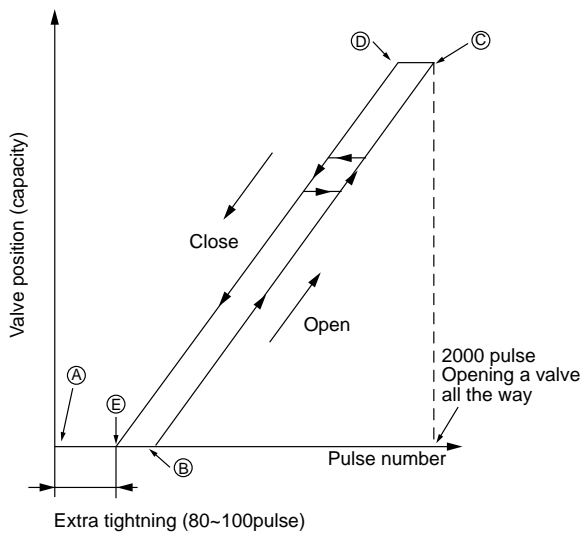

- \* When the switch is turned on, 2200 pulse closing valve signal will be send till it goes to A point in order to define the valve position.

When the valve move smoothly, there is no noise or vibration occurring from the linear expansion valve : however, when the pulse number moves from E to A or when the valve is locked, more noise can be heard than normal situation.

- \* Noise can be detected by placing the ear against the screw driver handle while putting the screw driver to the linear expansion valve.

#### ③ Trouble shooting

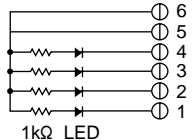
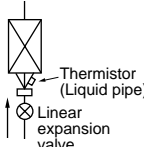
Symptom	Check points	Countermeasures
Operation circuit failure of the micro processor.	Disconnect the connector on the controller board, then connect LED for checking.  Pulse signal will be sent out for 10 seconds as soon as the main switch is turn on. If there is LED with lights on or lights off, it means the operation circuit is abnormal.	Exchange the indoor controller board at drive circuit failure.
Linear expansion valve mechanism is locked.	Motor will idle and make ticking noise when motor is operated while the linear expansion valve is locked. This ticking sound is the sign of the abnormality.	Exchange the linear expansion vale.
Short or breakage of the motor coil of the linear expansion valve.	Measure the resistance between the each coil (red-white, red-orange, brown-yellow, brown-blue) using a tester. It is normal if the resistance is in the range of $150\Omega \pm 10\%$ .	Exchange the linear expansion valve.
Valve doesn't close completely (thermistor leaking).	To check the linear expansion valve, operate the indoor unit in fan mode and at the same time operate other indoor units in cooling mode, then check the pipe temperature <liquid pipe temperature> of the indoor unit by the outdoor multi controller board operation monitor. During fan operation, linear expansion valve is closed completely and if there are some leaking, detecting temperature of the thermistor will go lower. If the detected temperature is much lower than the temperature indicated in the remote controller, it means the valve is not closed all the way. It is not necessary to exchange the linear expansion valve, if the leakage is small and not making any trouble. 	If large amount of thermistor is leaked, exchange the linear expansion valve.
Wrong connection of the connector or contact failure.	Check the color of lead wire and missing terminal of the connector.	Disconnect the connector at the controller board, then check the continuity.

## 7-2. TROUBLE SHOOTING

Check method of indoor fan motor (fan motor / control p.c.board)

① Notes

- High voltage is applied to the connector (FAN) for the fan motor. Give attention to the service.
- Do not pull out the connector (Fan) for the motor with the power supply on.  
(It causes trouble of the control p.c.board)

② Self check

Conditions : The indoor fan cannot turn around.

Wiring contact check  
Contact of fan motor connector (FAN)  
Contact of power supply cable.



Was contact caused good?

→ NO →

Wiring recovery

↓Yes

Fan motor check  
Measure the resistance between the fan motor connector ①(+) and ③(-).  
(With the connector is pulled out from the p.c.board)



Is the resistance 1MΩ or more?

→ NO →

Trouble of the fan motor Replacement of the motor

↓Yes

Power supply check  
Check the voltage in the indoor control p.c.board  
Approx. 310~340V between the connector (FAN) ①(+) and ③(-).  
Approx. 1~3V between the connector (FAN) ⑤(+) and ③(-).  
(The voltage between the ⑤ and ③ is a value during the fan motor operation.)  
(In the case that the fan motor off, the voltage is 0V.)



Is the voltage normal?

→ NO →

Trouble of the indoor p.c.board  
Replacement of the indoor control p.c.board

↓Yes

Fan motor position sensor signal check  
Turn around the fan motor more than one revolution slowly, and check the voltage between the connector (FAN) ⑥(+) and ③(-).



Does the voltage repeat DC0V and DC15V?

→ NO →

Trouble of the fan motor  
Replacement of the motor

↓Yes







Replacement of the indoor control p.c.board

### 7-3. FUNCTION OF DIP SWITCH

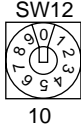
PMFY-P20VBM-E PMFY-P25VBM-E PMFY-P32VBM-E PMFY-P40VBM-E

Switch	Pole	Function	Operation by switch		Remarks																																				
			ON	OFF																																					
SW1 Mode Selection	1	Thermistor <intake temperature detection> position	Built-in remote controller	Indoor unit	<div style="border: 1px solid black; padding: 2px;">Address board</div> <At delivery> <table style="margin-left: 20px;"> <tr> <td>ON</td> <td><input type="checkbox"/></td><td><input type="checkbox"/></td><td><input type="checkbox"/></td><td><input type="checkbox"/></td><td><input type="checkbox"/></td><td><input type="checkbox"/></td><td><input type="checkbox"/></td><td><input type="checkbox"/></td><td><input type="checkbox"/></td> </tr> <tr> <td>OFF</td> <td><input type="checkbox"/></td><td><input type="checkbox"/></td><td><input type="checkbox"/></td><td><input type="checkbox"/></td><td><input type="checkbox"/></td><td><input type="checkbox"/></td><td><input type="checkbox"/></td><td><input type="checkbox"/></td><td><input type="checkbox"/></td> </tr> <tr> <td></td> <td>1</td><td>2</td><td>3</td><td>4</td><td>5</td><td>6</td><td>7</td><td>8</td><td>9</td><td>10</td> </tr> </table> ※1 Fan operation at Heating mode. ※2 Heater thermo ON is operating. ※3 SW 1-7=OFF, SW 1-8=ON → Setting air flow. SW 1-7=OFF, SW 1-8=ON → Indoor fan stop.	ON	<input type="checkbox"/>	<input type="checkbox"/>	<input type="checkbox"/>	<input type="checkbox"/>	<input type="checkbox"/>	<input type="checkbox"/>	<input type="checkbox"/>	<input type="checkbox"/>	<input type="checkbox"/>	OFF	<input type="checkbox"/>	<input type="checkbox"/>	<input type="checkbox"/>	<input type="checkbox"/>	<input type="checkbox"/>	<input type="checkbox"/>	<input type="checkbox"/>	<input type="checkbox"/>	<input type="checkbox"/>		1	2	3	4	5	6	7	8	9	10					
	ON	<input type="checkbox"/>	<input type="checkbox"/>	<input type="checkbox"/>		<input type="checkbox"/>	<input type="checkbox"/>	<input type="checkbox"/>	<input type="checkbox"/>	<input type="checkbox"/>	<input type="checkbox"/>																														
	OFF	<input type="checkbox"/>	<input type="checkbox"/>	<input type="checkbox"/>		<input type="checkbox"/>	<input type="checkbox"/>	<input type="checkbox"/>	<input type="checkbox"/>	<input type="checkbox"/>	<input type="checkbox"/>																														
		1	2	3		4	5	6	7	8	9	10																													
	2	Filter crogging detection	Provided	Not provided																																					
	3	Filter cleaning sign	2,500hr	100hr																																					
	4	Fresh air intake	Effective	Not effective																																					
	5	Remote indication switching	Thermostat ON signal indication	Fan output indication																																					
	6	Humidifier control	Always operated while the heat in ON ※1	Operated depends on the condition ※2																																					
	7	Air flow at	Low ※3	Extra low ※3																																					
8	Heat thermostat OFF	Setting air flow	Depends on SW1-7																																						
9	Auto restart function	Effective	Not effective																																						
10	Power source ON/OFF	Effective	Not effective																																						
SW2 Capacity code setting	1~6	Capacity	SW 2	Capacity	SW 2	<div style="border: 1px solid black; padding: 2px;">Indoor controller board</div> Set while the unit is off. <At delivery> Set for each capacity.																																			
		P20	ON OFF <table style="display: inline-table; border-collapse: collapse;"><tr><td><input type="checkbox"/></td><td><input type="checkbox"/></td><td><input type="checkbox"/></td><td><input type="checkbox"/></td><td><input type="checkbox"/></td><td><input type="checkbox"/></td></tr><tr><td>1</td><td>2</td><td>3</td><td>4</td><td>5</td><td>6</td></tr></table>	<input type="checkbox"/>	<input type="checkbox"/>		<input type="checkbox"/>	<input type="checkbox"/>	<input type="checkbox"/>	<input type="checkbox"/>	1	2	3	4	5	6	P32	ON OFF <table style="display: inline-table; border-collapse: collapse;"><tr><td><input type="checkbox"/></td><td><input type="checkbox"/></td><td><input type="checkbox"/></td><td><input type="checkbox"/></td><td><input type="checkbox"/></td><td><input type="checkbox"/></td></tr><tr><td>1</td><td>2</td><td>3</td><td>4</td><td>5</td><td>6</td></tr></table>	<input type="checkbox"/>	<input type="checkbox"/>	<input type="checkbox"/>	<input type="checkbox"/>	<input type="checkbox"/>	<input type="checkbox"/>	1	2	3	4	5	6											
		<input type="checkbox"/>	<input type="checkbox"/>	<input type="checkbox"/>	<input type="checkbox"/>		<input type="checkbox"/>	<input type="checkbox"/>																																	
		1	2	3	4		5	6																																	
<input type="checkbox"/>	<input type="checkbox"/>	<input type="checkbox"/>	<input type="checkbox"/>	<input type="checkbox"/>	<input type="checkbox"/>																																				
1	2	3	4	5	6																																				
P25	ON OFF <table style="display: inline-table; border-collapse: collapse;"><tr><td><input type="checkbox"/></td><td><input type="checkbox"/></td><td><input type="checkbox"/></td><td><input type="checkbox"/></td><td><input type="checkbox"/></td><td><input type="checkbox"/></td></tr><tr><td>1</td><td>2</td><td>3</td><td>4</td><td>5</td><td>6</td></tr></table>	<input type="checkbox"/>	<input type="checkbox"/>	<input type="checkbox"/>	<input type="checkbox"/>	<input type="checkbox"/>	<input type="checkbox"/>	1	2	3	4	5	6	P40	ON OFF <table style="display: inline-table; border-collapse: collapse;"><tr><td><input type="checkbox"/></td><td><input type="checkbox"/></td><td><input type="checkbox"/></td><td><input type="checkbox"/></td><td><input type="checkbox"/></td><td><input type="checkbox"/></td></tr><tr><td>1</td><td>2</td><td>3</td><td>4</td><td>5</td><td>6</td></tr></table>	<input type="checkbox"/>	<input type="checkbox"/>	<input type="checkbox"/>	<input type="checkbox"/>	<input type="checkbox"/>	<input type="checkbox"/>	1	2	3	4	5	6														
<input type="checkbox"/>	<input type="checkbox"/>	<input type="checkbox"/>	<input type="checkbox"/>	<input type="checkbox"/>	<input type="checkbox"/>																																				
1	2	3	4	5	6																																				
<input type="checkbox"/>	<input type="checkbox"/>	<input type="checkbox"/>	<input type="checkbox"/>	<input type="checkbox"/>	<input type="checkbox"/>																																				
1	2	3	4	5	6																																				
SW3 Function Selection	1	Heat pump / Cool only	Cooling only	Heat pump	<div style="border: 1px solid black; padding: 2px;">Indoor controller board</div> Set while the unit is off. <At delivery> <table style="margin-left: 20px;"> <tr> <td>ON</td> <td><input type="checkbox"/></td><td><input type="checkbox"/></td><td><input type="checkbox"/></td><td><input type="checkbox"/></td><td><input type="checkbox"/></td><td><input type="checkbox"/></td><td><input type="checkbox"/></td><td><input type="checkbox"/></td><td><input type="checkbox"/></td> </tr> <tr> <td>OFF</td> <td><input type="checkbox"/></td><td><input type="checkbox"/></td><td><input type="checkbox"/></td><td><input type="checkbox"/></td><td><input type="checkbox"/></td><td><input type="checkbox"/></td><td><input type="checkbox"/></td><td><input type="checkbox"/></td><td><input type="checkbox"/></td> </tr> <tr> <td></td> <td>1</td><td>2</td><td>3</td><td>4</td><td>5</td><td>6</td><td>7</td><td>8</td><td>9</td><td>10</td> </tr> </table> ※4 At cooling mode, each angle can be used only 1 hour. ※5 SW 3-9 setting P20, P25 = ON P32, P40 = OFF SW 3-10 setting P20, P25 = ON P32, P40 = OFF ※6 The numerical valve in the parentheses shows the case which the R22 outdoor unit is connected.	ON	<input type="checkbox"/>	<input type="checkbox"/>	<input type="checkbox"/>	<input type="checkbox"/>	<input type="checkbox"/>	<input type="checkbox"/>	<input type="checkbox"/>	<input type="checkbox"/>	<input type="checkbox"/>	OFF	<input type="checkbox"/>	<input type="checkbox"/>	<input type="checkbox"/>	<input type="checkbox"/>	<input type="checkbox"/>	<input type="checkbox"/>	<input type="checkbox"/>	<input type="checkbox"/>	<input type="checkbox"/>		1	2	3	4	5	6	7	8	9	10					
	ON	<input type="checkbox"/>	<input type="checkbox"/>	<input type="checkbox"/>		<input type="checkbox"/>	<input type="checkbox"/>	<input type="checkbox"/>	<input type="checkbox"/>	<input type="checkbox"/>	<input type="checkbox"/>																														
	OFF	<input type="checkbox"/>	<input type="checkbox"/>	<input type="checkbox"/>		<input type="checkbox"/>	<input type="checkbox"/>	<input type="checkbox"/>	<input type="checkbox"/>	<input type="checkbox"/>	<input type="checkbox"/>																														
		1	2	3		4	5	6	7	8	9	10																													
	2	Louver	Available	Not available																																					
	3	Vane	Available	Not available																																					
	4	Vane swing function	Available	Not available																																					
	5	Vane horizontal angle	Second setting	First setting																																					
	6	Vane cooling limit angle setting ※4	Horizontal angle	Down B, C																																					
	7	Indoor linear expansion valve opening change	Effective	Not effective																																					
8	Heating 4deg. up	Not effective	Effective																																						
9	Target superheat setting ※5	9deg. (5deg.) ※6	6deg. (2deg.) ※6																																						
10	Target sub cool setting ※5	15deg.	10deg.																																						
SW4 Unit Selection	1~5	<table style="margin-left: 20px;"> <tr> <td>ON</td> <td><input type="checkbox"/></td><td><input type="checkbox"/></td><td><input type="checkbox"/></td><td><input type="checkbox"/></td><td><input type="checkbox"/></td> </tr> <tr> <td>OFF</td> <td><input type="checkbox"/></td><td><input type="checkbox"/></td><td><input type="checkbox"/></td><td><input type="checkbox"/></td><td><input type="checkbox"/></td> </tr> <tr> <td></td> <td>1</td><td>2</td><td>3</td><td>4</td><td>5</td> </tr> </table>			ON	<input type="checkbox"/>	<input type="checkbox"/>	<input type="checkbox"/>	<input type="checkbox"/>	<input type="checkbox"/>	OFF	<input type="checkbox"/>	<input type="checkbox"/>	<input type="checkbox"/>	<input type="checkbox"/>	<input type="checkbox"/>		1	2	3	4	5	<div style="border: 1px solid black; padding: 2px;">Indoor controller board</div> Set while the unit is off. <table style="margin-left: 20px;"> <tr> <td>ON</td> <td><input type="checkbox"/></td><td><input type="checkbox"/></td><td><input type="checkbox"/></td><td><input type="checkbox"/></td><td><input type="checkbox"/></td> </tr> <tr> <td>OFF</td> <td><input type="checkbox"/></td><td><input type="checkbox"/></td><td><input type="checkbox"/></td><td><input type="checkbox"/></td><td><input type="checkbox"/></td> </tr> <tr> <td></td> <td>1</td><td>2</td><td>3</td><td>4</td><td>5</td> </tr> </table>	ON	<input type="checkbox"/>	<input type="checkbox"/>	<input type="checkbox"/>	<input type="checkbox"/>	<input type="checkbox"/>	OFF	<input type="checkbox"/>	<input type="checkbox"/>	<input type="checkbox"/>	<input type="checkbox"/>	<input type="checkbox"/>		1	2	3	4	5
		ON	<input type="checkbox"/>	<input type="checkbox"/>	<input type="checkbox"/>	<input type="checkbox"/>	<input type="checkbox"/>																																		
OFF	<input type="checkbox"/>	<input type="checkbox"/>	<input type="checkbox"/>	<input type="checkbox"/>	<input type="checkbox"/>																																				
	1	2	3	4	5																																				
ON	<input type="checkbox"/>	<input type="checkbox"/>	<input type="checkbox"/>	<input type="checkbox"/>	<input type="checkbox"/>																																				
OFF	<input type="checkbox"/>	<input type="checkbox"/>	<input type="checkbox"/>	<input type="checkbox"/>	<input type="checkbox"/>																																				
	1	2	3	4	5																																				

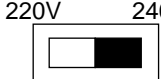
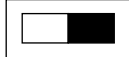

Switch	Pole	Operation by switch	Remarks
SW11 1st digit address setting SW12 2nd digit address setting	Rotary switch	  <p>Address setting should be done when M-NET remote controller is being used.</p>	<p><b>Address board</b></p> <p>Address can be set while the unit is stopped.</p> <p>&lt;At delivery&gt;</p>  
SW14 Connection No. setting	Rotary switch	 <p>This is the switch to be used when the indoor unit is operated with R2 series outdoor unit as a set.</p>	<p><b>Address board</b></p> <p>&lt;At delivery&gt;</p> 
SW5 Voltage Selection	2	 <p>If the unit is used at the 230V or 240V area, set the voltage to 240V. If the unit is used at the 220V, set the voltage to 220V.</p>	<p><b>Address board</b></p> <p>&lt;At delivery&gt;</p> 

# 7-4. TEST POINT DIAGRAM

Indoor controller board  
 PMFY-P20VBM-E  
 PMFY-P25VBM-E  
 PMFY-P32VBM-E  
 PMFY-P40VBM-E

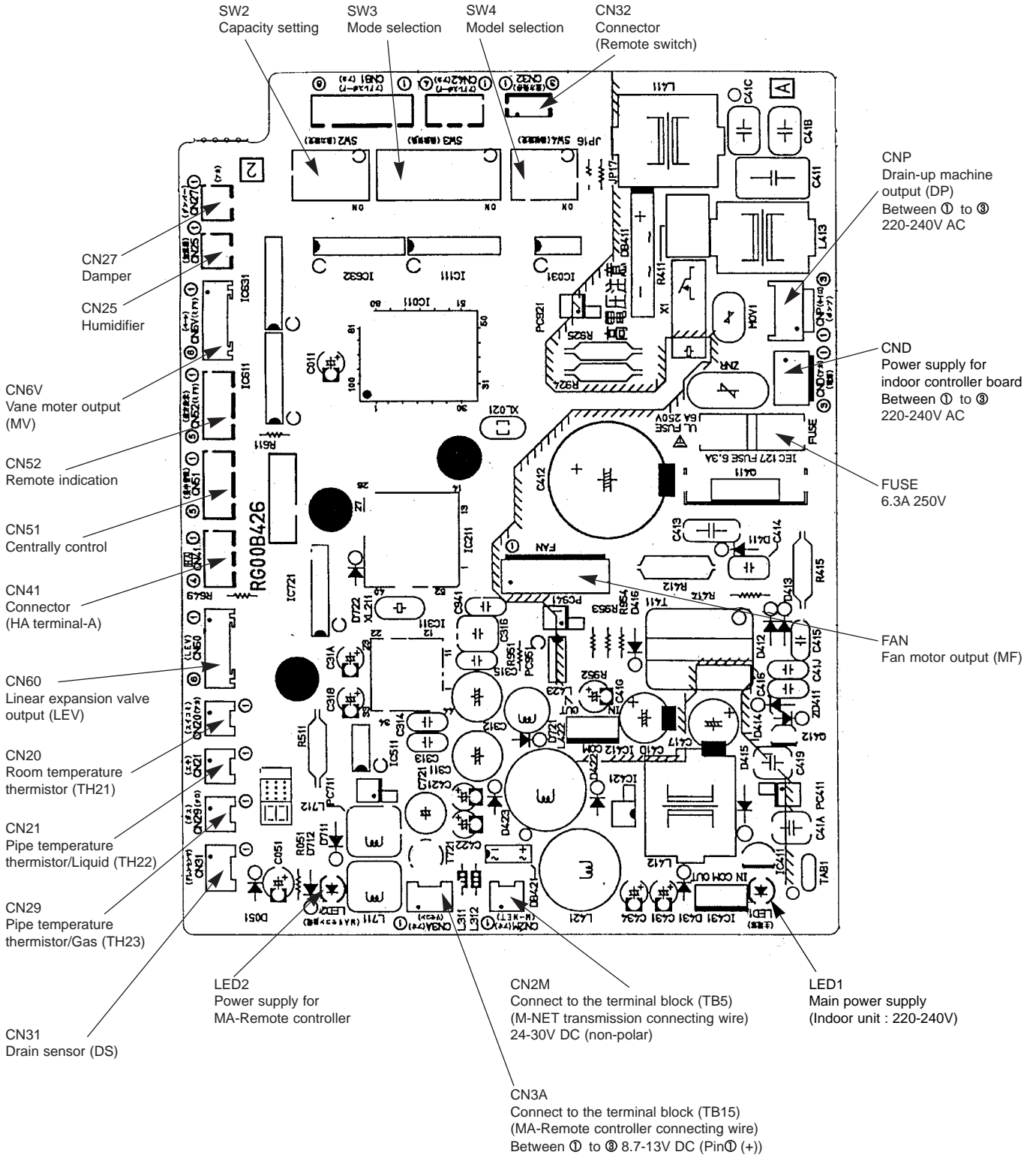

Be careful on removing heavy parts.

### PMFY-P32VBM-E

#### OPERATING PROCEDURE

##### 1. Removing the intake grille

###### Opening the air intake grille

- (1) Press the **PUSH** of the air intake grille.(See figure 1)
- (2) Put your figure on the both end of nut of the air intake grille and put it down after the grille clicked.

###### Removing the air intake grille

- (1) Press the **PUSH** of air intake grille, and pull down the both end of nut with your fingers after the grille clicked. (See figure 1)
- (2) Pull out the handle of air intake grille strong toward you. (See figure 2)
- (3) Draw the string of air intake grille to prevent the grille from dropping.(See figure 3)

#### PHOTOS&ILLUSTRATIONS

Photo 1



Figure 1

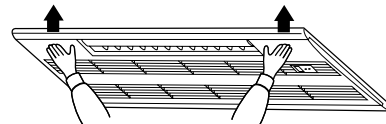

Figure 2

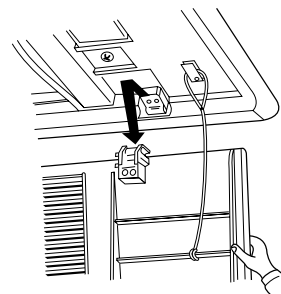
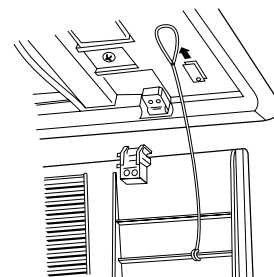

Figure 3





**OPERATING PROCEDURE**

**2. Removing the electrical parts box**

- (1) Remove the panel.
- (2) Remove the address board cover.
- (3) Remove the electrical parts cover.
- (4) Disconnect the connectors of fan motor, vane motor, drain pump, room temperature thermistor, pipe temperature thermistor, condenser/evaporator temperature thermistor, and drain sensor on the electrical controller board.
- (5) Disconnect the lead wire and earth wire from terminal block.
- (6) Remove the electrical parts box.

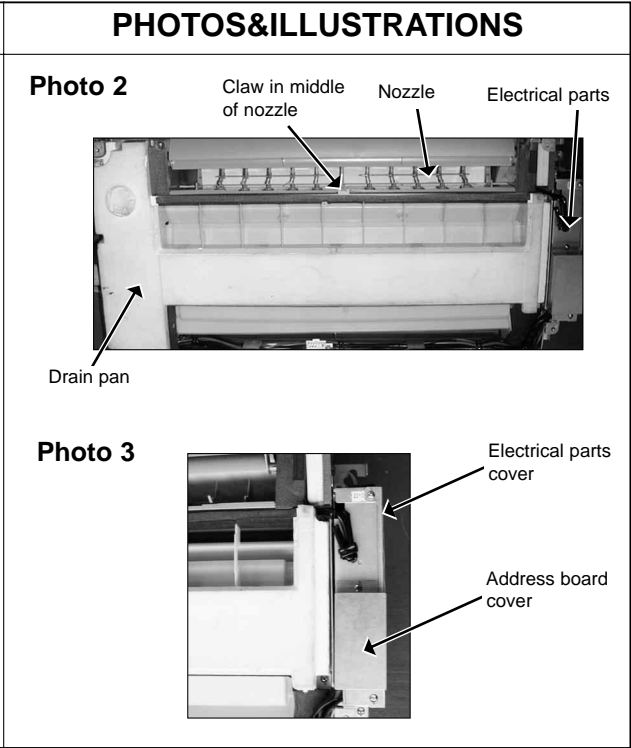

**3. Removing the nozzle**

**Note when the nozzle is removed**

- The white insulation material which prevents water drop is mounted to the side of vane motor, remove the insulation material before removing nozzle. (See figure 4)
- After completing the service, re-mount the insulation material as before as shown in right figure.
- After service, mount the double layer insulation without fail. The hard material side should be faced to the nozzle. (See figure 4)

- (1) Remove the panel.
- (2) Remove the room temperature thermistor.
- (3) Unhook the claw in the middle of nozzle and remove the drain pan. (5 screws) (See photo 2)
- (4) Remove the nozzle side of the heat exchanger.(2 screws)
- (5) Remove the address board cover.
- (6) Remove the electrical parts cover.
- (7) Disconnect the connector of vane motor.
- (8) Remove the insulation material (white) on the right side of nozzle.
- (9) Remove the nozzle. (6 screws)

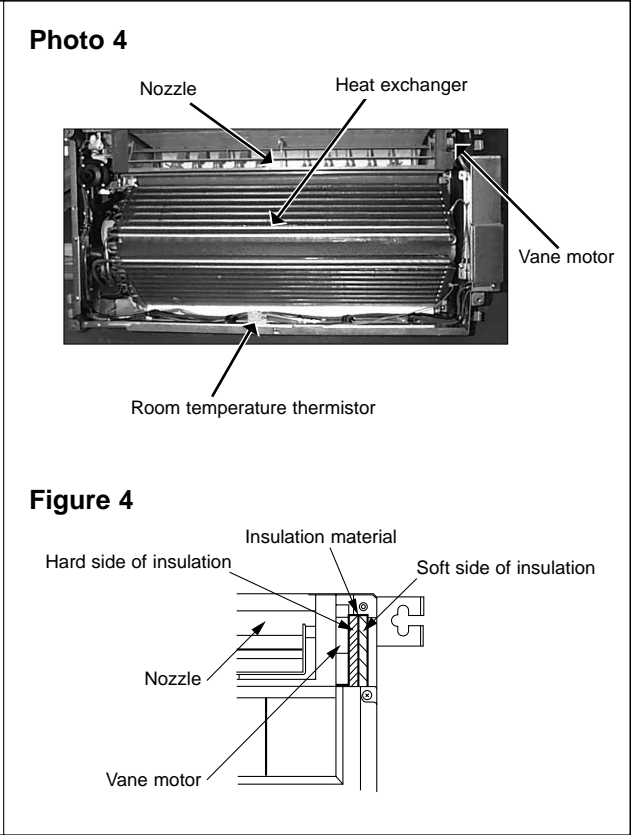

**4. Removing the vane motor**

- (1) Remove the nozzle. Refer to above-mentioned (3) Removing the nozzle.
- (2) Remove the vane motor.

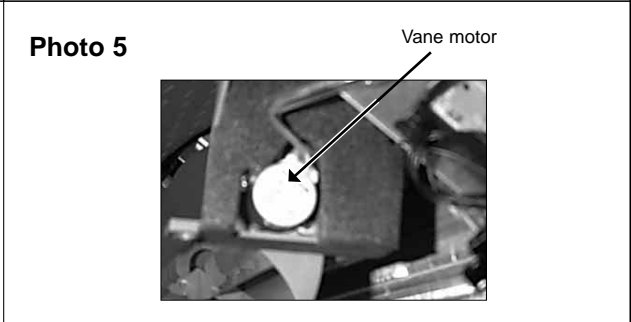



**OPERATING PROCEDURE**

**PHOTOS&ILLUSTRATIONS**

**5. Removing the drain pump**

- (1) Remove the panel.
- (2) Unhook the claw in the middle of nozzle and remove the drain pan.
- (3) Remove the address board cover.
- (4) Remove the electrical parts cover.
- (5) Disconnect the connector of drain pump.
- (6) Remove the drain hose.
- (7) Remove the drain pump.(2 screws)

**Photo 6**

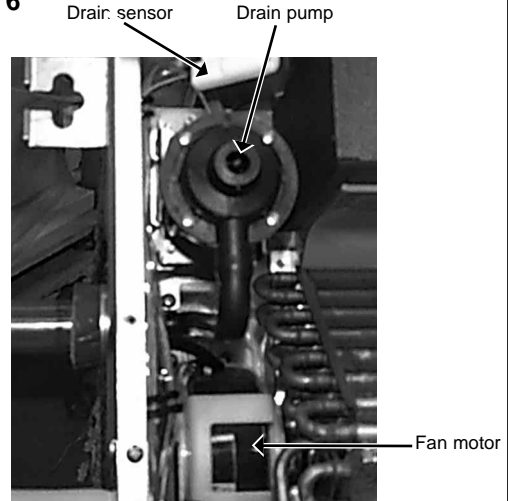

**6. Removing the fan motor and line flow fan**

- (1) Remove the panel.
- (2) Unhook the claw in the middle of nozzle and remove the drain pan.
- (3) Unscrew 2 screws at the nozzle side of the heat exchanger.
- (4) Remove the address board cover.
- (5) Remove the electrical parts cover.
- (6) Disconnect the connector of vane motor, fan motor and drain pump.
- (7) Remove the nozzle side of the heat exchanger.(2 screws)
- (8) Remove the nozzle.
- (9) Remove the drain pump.
- (10) Unscrew 2 screws in the motor support.
- (11) Remove the fan motor and line flow fan (The fan motor and line flow fan can be removed without removing the heat exchanger.)

**Photo 7**

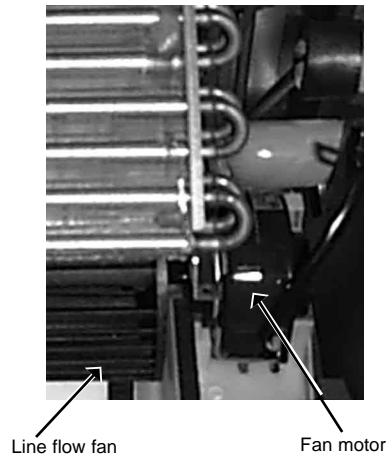

**7. Removing the thermistor<Intake temperature detector>**

- (1) Remove the panel.
- (2) Remove the address board cover.
- (3) Remove the electrical parts cover.
- (4) Remove the thermistor <intake temperature detector>
- (5) Disconnect the lead wire from the cord clamp (5 points)
- (6) Disconnect the connector (CN20) on the indoor controller board.

**8. Removing the thermistor<Liquid pipe temperature detector>  
<Gas pipe temperature detector>**

- (1) Remove the panel.
- (2) Remove the address board cover.
- (3) Remove the electrical parts cover.
- (4) Remove the drain pan.
- (5) Remove the thermistor <Gas pipe temperature detector> /<Liquid pipe temperature detector>.
- (6) Disconnect the lead wire from the cord clamp
- (7) Disconnect the connector (CN21)/(CN29) on the indoor controller board.



PANEL PARTS  
 PMFY-P20VBM-E  
 PMFY-P25VBM-E  
 PMFY-P32VBM-E  
 PMFY-P40VBM-E

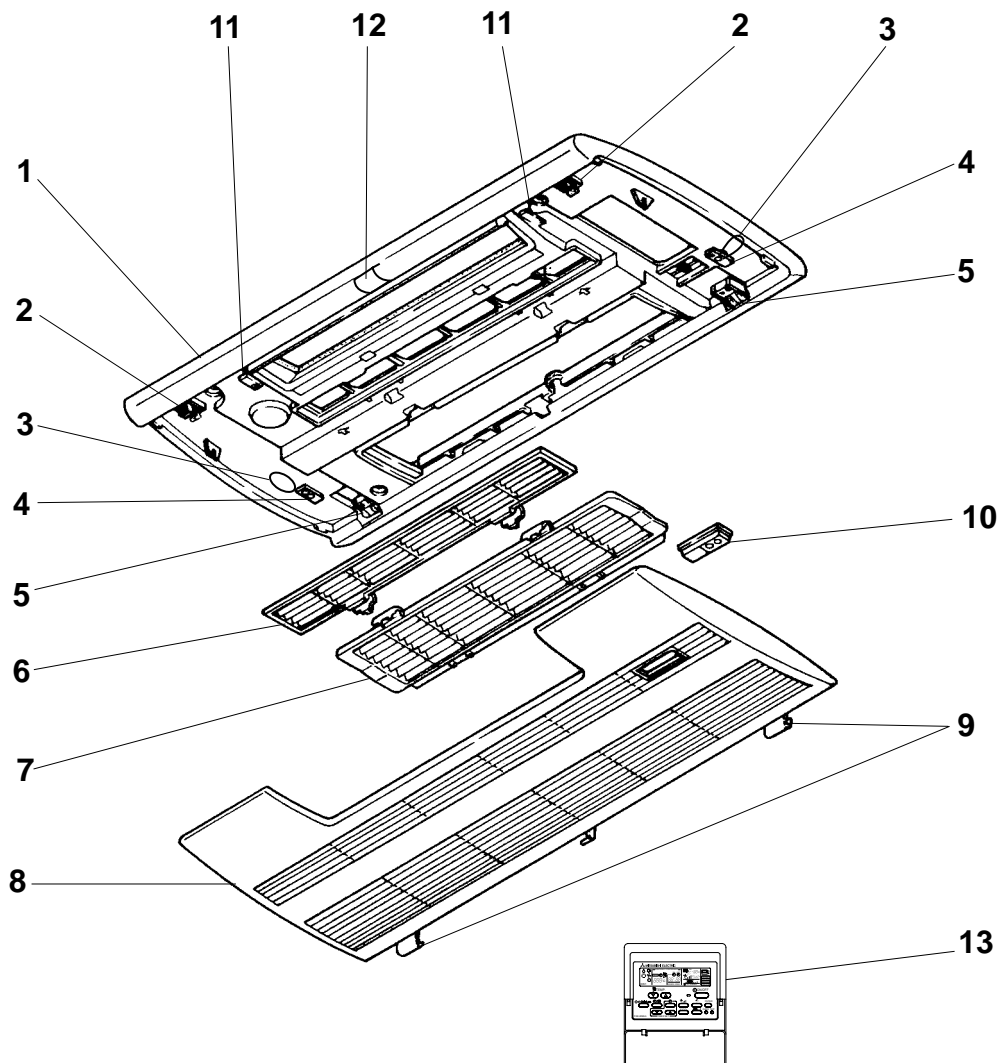

No.	Part No.	Part Name	Specification	Q'ty/set	Remarks (Drawing No.)	Wiring Diagram Symbol	Recom- mended Q'ty	Price	
				PMFY- P20,P25,P32,P40 VBM-E				Unit	Amount
1	T7W E11 003	AIR OUTLET GRILLE		1					
2	R01 E00 055	LATCH		2					
3	—	HANGER		2	(DT88D360H03)				
4	R01 E00 099	PANEL HOOK		2					
5	RO1 E01 054	GRILLE CATCH		2					
6	RO1 E01 500	L.L.FILTER		1					
7	R01 E02 500	L.L.FILTER		1					
8	TW7 E01 691	INTAKE GRILLE		1					
9	R01 E00 054	GRILLE CATCH		2					
10	R01 E00 648	RECEIVER COVER		1					
11	R01 E00 044	MAGNET		2					
12	R01 E00 096	SCREW CAP		1					
13	—	REMOTE CONTROLLER	PAR-20MAA	1		R.B			

**FUNCTIONAL PARTS**  
**PMFY-P20VBM-E**  
**PMFY-P25VBM-E**  
**PMFY-P32VBM-E**  
**PMFY-P40VBM-E**

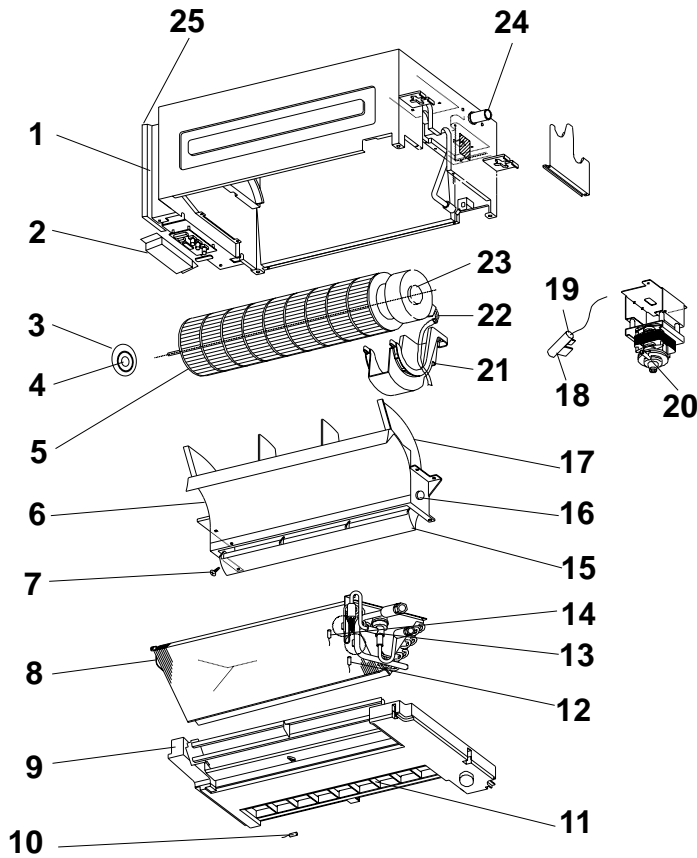

Part number that is circled is not shown in the figure.

No.	Part No.	Part Name	Specification	Q'ty/set		Remarks (Drawing No.)	Wiring Diagram Symbol	Recom- mended Q'ty	Price	
				PMFY-P · VBM-E					Unit	Amount
				20, 25	32, 40					
1	—	CABINET		1	1	(DT00A478G78)				
2	—	ADDRESS BOARD COVER		1	1	(RG02L277H02)				
3	R01 22A 102	BEARING MOUNT		1	1					
4	R01 005 103	SLEEVE BEARING		1	1					
5	R01 E02 114	LINE FLOW FAN		1	1					
6	R01 E00 079	STABILIZER ASSY		1	1					
7	R01 E00 092	VANE SLEEVE		1	1					
8	T7W E48 480	HEAT EXCHANGER		1						
	T7W E49 480	HEAT EXCHANGER			1					
9	R01 E10 529	DRAIN PAN		1	1					
10	R01 E00 202	THERMISTOR	ROOM	1	1		TH21			
11	R01 E00 038	GUIDE VANE		1	1					
12	R01 E01 202	THERMISTOR	LIQUID	1	1		TH22			
13	R01 E66 401	LINEAR EXPANSION VALVE		1	1		LEV			
14	R01 E03 202	THERMISTOR	GAS	1	1		TH23			
15	R01 E01 002	VANE		1	1					
16	R01 E01 223	VANE MOTOR		1	1		MV			
17	R01 E00 110	CASING		1	1					
18	R01 31K 241	SENSOR HOLDER		1	1					
19	R01 E01 266	DRAIN SENSOR		1	1		DS			
20	T7W E02 355	DRAIN PUMP		1	1		DP			
21	R01 E00 130	MOTOR SUPPORT		1	1					
22	R01 E03 220	FAN MOTOR		1	1		MF			
23	R01 E01 105	MOTOR MOUNT		1	1					
24	R01 E00 527	DRAIN PIPE		1	1					
25	—	CONTROL BOX COVER		1	1	(RG00L311G11)				
26	R01 E01 673	SCREW ASSY		1	1					

**ELECTRICAL PARTS**  
**PMFY-P20VBM-E**  
**PMFY-P25VBM-E**  
**PMFY-P32VBM-E**  
**PMFY-P40VBM-E**

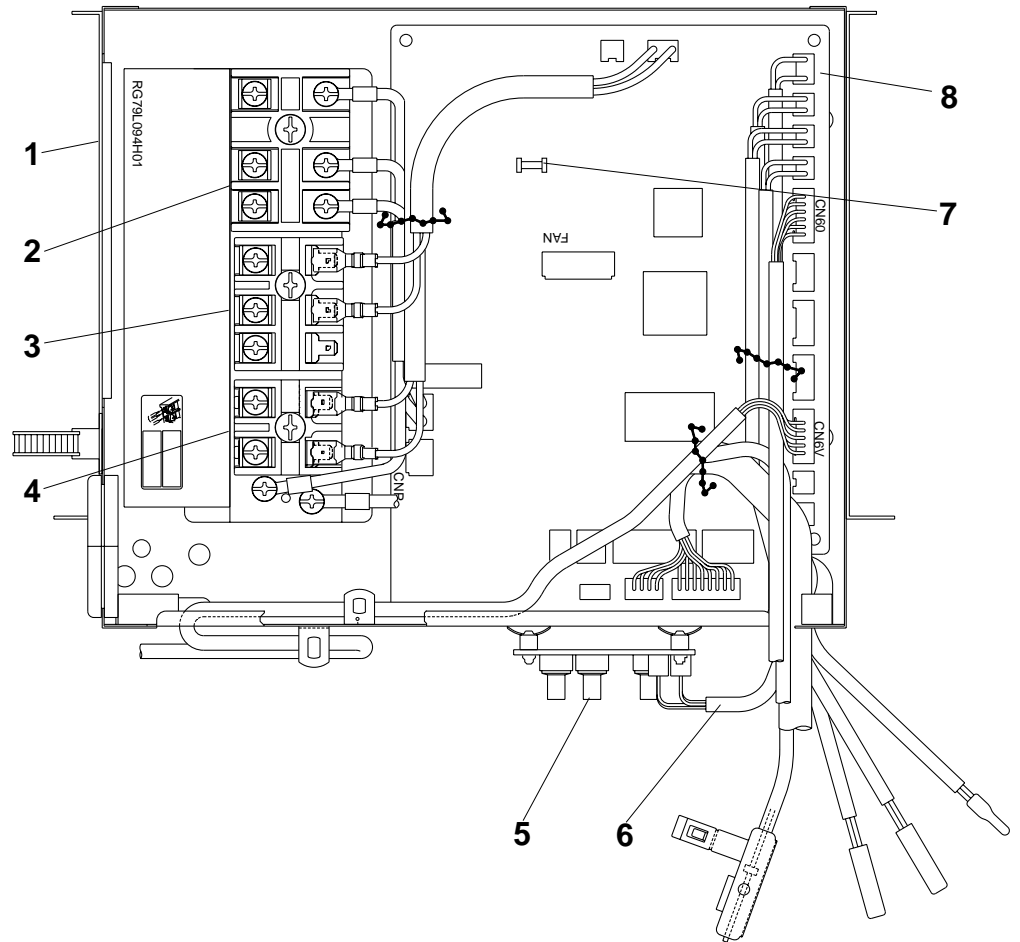

No.	Part No.	Part Name	Specification	Q'ty/set	Remarks (Drawing No.)	Wiring Diagram Symbol	Recom- mended Q'ty	Price	
				PMFY- P20, P25, P32, P40 VBM-E				Unit	Amount
1	—	CONTROL BOX		1	(RG02B337G14)				
2	T7W A14 716	TERMINAL BLOCK	3P (L,N,⊕)	1		TB2			
3	T7W E00 716	TERMINAL BLOCK	3P (M1,M2,S)	1		TB5			
4	T7W 515 716	TERMINAL BLOCK	2P(1,2)	1		TB15			
5	T7W B01 294	ADDRESS BOARD		1		A.B			
6	R01 E00 304	CABLE ASSY		1					
7	T7W 520 239	FUSE	250V 6.3A	1		FUSE			
8	T7W E35 310	INDOOR CONTROLLER BOARD	with POWER BOARD	1		I.B			

