

PKFY-P-VBM-E, VHM-E, VKM-E

1. SPECIFICATIONS	1 - 150
2. EXTERNAL DIMENSIONS	1 - 152
3. CENTER OF GRAVITY	1 - 155
4. ELECTRICAL WIRING DIAGRAMS	1 - 156
5. SOUND LEVELS	1 - 159
5-1. Sound levels	1 - 159
5-2. NC curves	1 - 159
6. TEMPERATURE/AIRFLOW DISTRIBUTIONS	1 - 160
6-1. Temperature distributions	1 - 160
6-2. Airflow distributions	1 - 161
7. OPTIONAL PARTS.....	1 - 162
7-1. Optional parts line up for the Indoor unit.....	1 - 162
7-2. External LEV Box.....	1 - 162
7-3. Drain pump	1 - 162

1. SPECIFICATIONS

Model		PKFY-P15VBM-E	PKFY-P20VBM-E	PKFY-P25VBM-E	PKFY-P32VHM-E		
Power source		1-phase 220-240V 50Hz, 1-phase 220V 60Hz	1-phase 220-240V 50Hz, 1-phase 220V 60Hz	1-phase 220-240V 50Hz, 1-phase 220V 60Hz	1-phase 220-240V 50Hz, 1-phase 220V 60Hz		
Cooling capacity (Nominal)	*1 kW	1.7	2.2	2.8	3.6		
	*1 kcal / h	1,450	1,900	2,400	3,100		
	*1 BTU / h	5,800	7,500	9,600	12,300		
	*2 kcal / h	1,500	2,000	2,500	3,150		
(220V)	Power input *4 kW	0.04	0.04	0.04	0.04		
	Current input *4 A	0.20	0.20	0.20	0.40		
Heating capacity (Nominal)	*3 kW	1.9	2.5	3.2	4.0		
	*3 kcal / h	1,600	2,200	2,800	3,400		
	*3 BTU / h	6,500	8,500	10,900	13,600		
(220V)	Power input kW	0.04	0.04	0.04	0.03		
	Current input A	0.20	0.20	0.20	0.30		
External finish		Plastic, MUNSELL (1.0Y 9.2/0.2)	Plastic, MUNSELL (1.0Y 9.2/0.2)	Plastic, MUNSELL (1.0Y 9.2/0.2)	Plastic, MUNSELL (1.0Y 9.2/0.2)		
External dimension HxWxD		mm	295x815x225	295x815x225	295x815x225		
		in.	11-5/8 x 32-1/8 x 8-7/8	11-5/8 x 32-1/8 x 8-7/8	11-5/8 x 32-1/8 x 8-7/8	11-5/8 x 35-3/8 x 9-13/16	
Net weight		kg(lbs)	10 (23)	10 (23)	10 (23)		
Heat exchanger		Cross fin (Aluminum fin and copper tube)	Cross fin (Aluminum fin and copper tube)	Cross fin (Aluminum fin and copper tube)	Cross fin (Aluminum fin and copper tube)		
FAN	Type x Quantity		Line flow fan x 1	Line flow fan x 1	Line flow fan x 1	Line flow fan x 1	
	External static press.	Pa	0	0	0	0	
		mmH ₂ O	0	0	0	0	
	Motor Type		1-phase induction motor	1-phase induction motor	1-phase induction motor	DC motor	
	Motor output		kW	0.017	0.017	0.017	0.030
	Driving mechanism		Direct-driven by motor	Direct-driven by motor	Direct-driven by motor	Direct-drive	
	Airflow rate (Low-Mid2-Mid-High)	m ³ / min	4.9-5.0-5.2-5.3	4.9-5.2-5.6-5.9	4.9-5.2-5.6-5.9	9-10-11	
		L/s	82-83-87-88	82-87-93-98	82-87-93-98	150-167-183	
cfm		173-177-184-187	173-184-198-208	173-184-198-208	318-353-388		
Sound pressure level (measured in anechoic room)		dB <A>	29-31-32-33	29-31-34-36	29-31-34-36	34-37-41	
Insulation material		Polyethylene sheet	Polyethylene sheet	Polyethylene sheet	Polyethylene sheet		
Air filter		PP honeycomb	PP honeycomb	PP honeycomb	PP honeycomb		
Protection device		Fuse	Fuse	Fuse	Fuse		
Refrigerant control device		LEV	LEV	LEV	LEV		
Connectable outdoor unit		PURY-P-Y(S)JM-A PUHY-P-Y(S)JM-A PUMY-P100~140VHMB PUMY-P100~140YHMB PQRY-P-Y(S)HM-A PQHY-P-Y(S)HM-A	R410A CITY MULTI	R410A CITY MULTI	R410A CITY MULTI		
Diameter of refrigerant pipe	Liquid (R410A)	mm(in.)	6.35(1/4) Flare	6.35(1/4) Flare	6.35(1/4) Flare	6.35(1/4) Flare	
	Gas (R410A)	mm(in.)	12.70(1/2) Flare	12.70(1/2) Flare	12.70(1/2) Flare	12.70(1/2) Flare	
Field drain pipe size		mm(in.)	I.D. 16(5/8)	I.D. 16(5/8)	I.D. 16(5/8)	I.D. 16(5/8)	
Drawing	External		-	-	-	-	
	Wiring		-	-	-	-	
	Refrigerant cycle		-	-	-	-	
Standard attachment	Document		Installation Manual, Instruction Book	Installation Manual, Instruction Book	Installation Manual, Instruction Book	Installation Manual, Instruction Book	
	Accessory		-	-	-	-	
Optional parts	External LEV Box		PAC-SG95LE-E	PAC-SG95LE-E	PAC-SG95LE-E	-	
	Drain pump		-	-	-	PAC-SH75DM-E	
Remarks		* Details on foundation work, duct work, insulation work, electrical wiring, power source switch, and other items shall be referred to the Installation Manual. * Due to continuing improvement, above specification may be subject to change without notice.					

PKFY

Notes :	*1 Nominal cooling conditions (subject to JIS B8615-1)	*2 Nominal cooling conditions	*3 Nominal heating conditions (subject to JIS B8615-1)	Unit converter
	Indoor : 27degC D.B. / 19degC W.B. (81degF D.B. / 66degF W.B.)	27degC D.B. / 19.5degC W.B. (81degF D.B. / 67degF W.B.)	20degC D.B. (68degF D.B.)	kcal/h = kW x 860
	Outdoor : 35degC D.B. (95degF D.B.)	35degC D.B. (95degF D.B.)	7degC D.B. / 6degC W.B. (45degF D.B. / 43degF W.B.)	BTU/h = kW x 3,412
	Pipe length : 7.5 m (24-9/16 ft.)	5 m (16-3/8 ft.)	7.5 m (24-9/16 ft.)	cfm = m3/min x 35.31
	Level difference : 0 m (0 ft.)	0 m (0 ft.)	0 m (0 ft.)	lbs = kg / 0.4536
				*The specification data is subject to rounding variation.
*4 Electrical characteristic of cooling are included optional drain-pump. (Applicable only to PKFY-P32VHM-E)				

1. SPECIFICATIONS

Model			PKFY-P40VHM-E	PKFY-P50VHM-E	PKFY-P63VKM-E	PKFY-P100VKM-E		
Power source			1-phase 220-240V 50Hz, 1-phase 220V 60Hz	1-phase 220-240V 50Hz, 1-phase 220V 60Hz	1-phase 220-240V 50Hz, 1-phase 220V 60Hz	1-phase 220-240V 50Hz, 1-phase 220V 60Hz		
Cooling capacity (Nominal)	*1	kW	4.5	5.6	7.1	11.2		
		kcal / h	3,900	4,800	6,100	9,600		
		BTU / h	15,400	19,100	24,200	38,200		
	(220V)	*2	kcal / h	4,000	5,000	6,300	10,000	
			Power input	*4 kW	0.04	0.04	0.05	0.08
			Current input	*4 A	0.40	0.40	0.37	0.58
Heating capacity (Nominal)	*3	kW	5.0	6.3	8.0	12.5		
		kcal / h	4,300	5,400	6,900	10,800		
		BTU / h	17,100	21,500	27,300	42,600		
	(220V)	*3	Power input	kW	0.03	0.03	0.04	0.07
			Current input	A	0.30	0.30	0.30	0.51
			External finish	Plastic, MUNSELL (1.0Y 9.2/0.2)		Plastic, MUNSELL (1.0Y 9.2/0.2)	Plastic, MUNSELL (1.0Y 9.2/0.2)	Plastic, MUNSELL (1.0Y 9.2/0.2)
External dimension HxWxD	mm	295x898x249		295x898x249	365x1170x295	365x1170x295		
	in.	11-5/8 x 35-3/8 x 9-13/16		11-5/8 x 35-3/8 x 9-13/16	14-3/8 x 46-1/16 x 11-5/8	14-3/8 x 46-1/16 x 11-5/8		
Net weight	kg(lbs)	13(29)		13(29)	21(46)	21(46)		
Heat exchanger			Cross fin (Aluminum fin and copper tube)	Cross fin (Aluminum fin and copper tube)	Cross fin (Aluminum fin and copper tube)	Cross fin (Aluminum fin and copper tube)		
FAN	Type x Quantity		Line flow fan x 1		Line flow fan x 1		Line flow fan x 1	
	External static press.	Pa	0		0		0	
		mmH ₂ O	0		0		0	
	Motor Type		DC motor		DC motor		DC motor	
	Motor output		kW		0.030		0.056	
	Driving mechanism		Direct-drive		Direct-drive		Direct-drive	
	Airflow rate (Low-Mid-High)	m ³ / min	9-10.5-11.5		9-10.5-12		16-20	
		L/s	150-175-192		150-175-200		267-333	
		cfm	318-371-406		318-371-424		565-706	
Sound pressure level (measured in anechoic room)			dB <A>		34-38-41		34-39-43	
Insulation material			Polyethylene sheet		Polyethylene sheet		Polyethylene sheet	
Air filter			PP honeycomb		PP honeycomb		PP honeycomb	
Protection device			Fuse		Fuse		Fuse	
Refrigerant control device			LEV		LEV		LEV	
Connectable outdoor unit			R410A CITY MULTI		R410A CITY MULTI		R410A CITY MULTI	
Diameter of refrigerant pipe	Liquid (R410A)	mm(in.)	6.35(1/4) Flare		6.35(1/4) Flare		9.52(3/8) Flare	
	Gas (R410A)	mm(in.)	12.70(1/2) Flare		12.70(1/2) Flare		15.88(5/8) Flare	
Field drain pipe size			mm(in.)		I.D. 16(5/8)		I.D. 16(5/8)	
Drawing	External		-		-		-	
	Wiring		-		-		-	
	Refrigerant cycle		-		-		-	
Standard attachment	Document		Installation Manual, Instruction Book		Installation Manual, Instruction Book		Installation Manual, Instruction Book	
	Accessory		-		-		-	
Optional parts	External LEV Box		-		-		-	
	Drain pump		PAC-SH75DM-E		PAC-SH75DM-E		PAC-SH94DM-E	
Remarks			* Details on foundation work, duct work, insulation work, electrical wiring, power source switch, and other items shall be referred to the Installation Manual. * Due to continuing improvement, above specification may be subject to change without notice.					

Notes :	*1 Nominal cooling conditions (subject to JIS B8615-1)	*2 Nominal cooling conditions	*3 Nominal heating conditions (subject to JIS B8615-1)	Unit converter
Indoor :	27degC D.B. / 19degC W.B. (81degF D.B. / 66degF W.B.)	27degC D.B. / 19.5degC W.B. (81degF D.B. / 67degF W.B.)	20degC D.B. (68degF D.B.)	kcal/h = kW x 860
Outdoor :	35degC D.B. (95degF D.B.)	35degC D.B. (95degF D.B.)	7degC D.B. / 6degC W.B. (45degF D.B. / 43degF W.B.)	BTU/h = kW x 3,412
Pipe length :	7.5 m (24-9/16 ft.)	5 m (16-3/8 ft.)	7.5 m (24-9/16 ft.)	cfm = m3/min x 35.31
Level difference :	0 m (0 ft.)	0 m (0 ft.)	0 m (0 ft.)	lbs = kg / 0.4536
				*The specification data is subject to rounding variation.
*4 Electrical characteristic of cooling are included optional drain-pump.				

PKFY

PKFY-P32, 40, 50VHM-E

Unit : mm

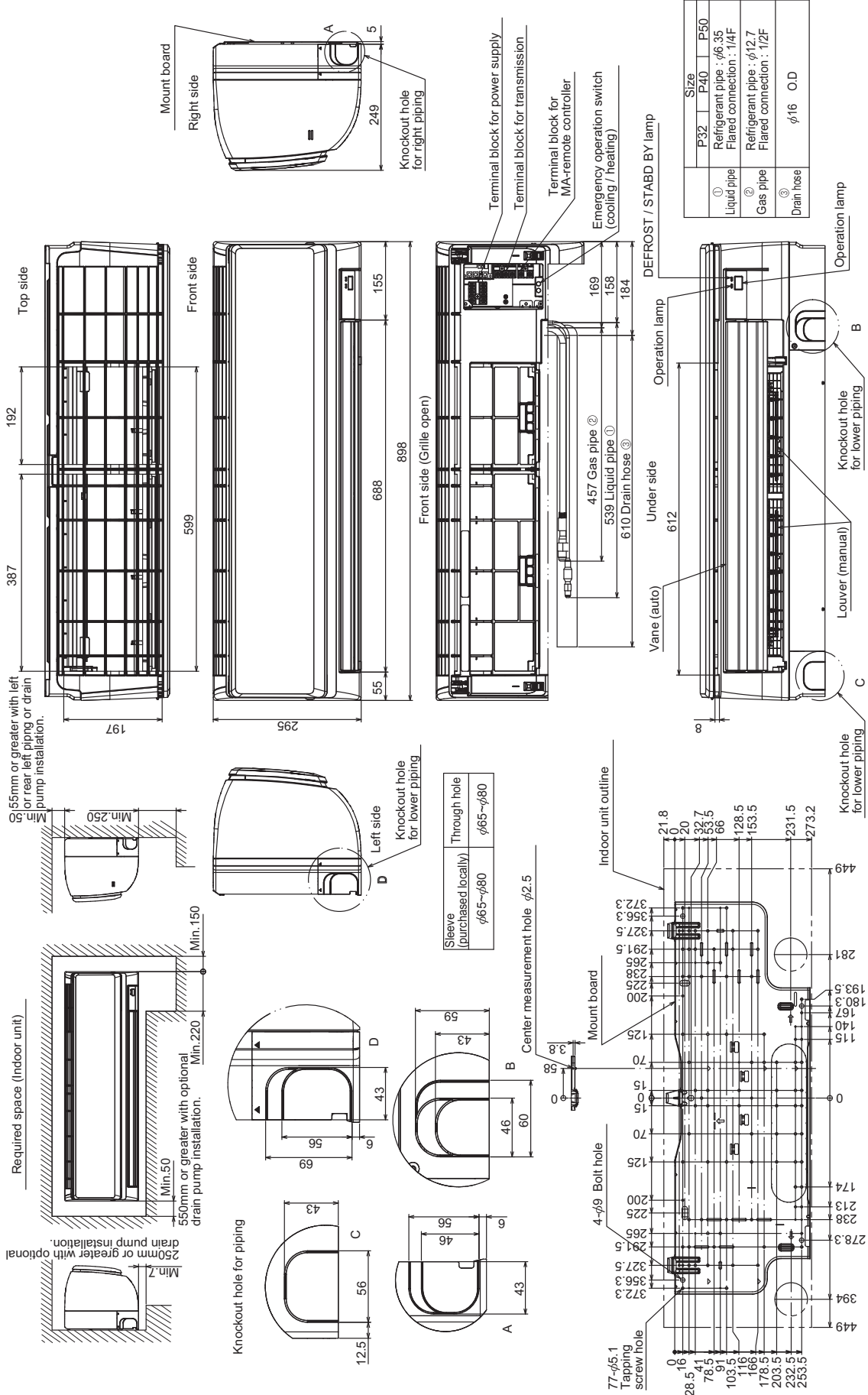

PKFY

PKFY-P63, 100VKM-E

Unit : mm

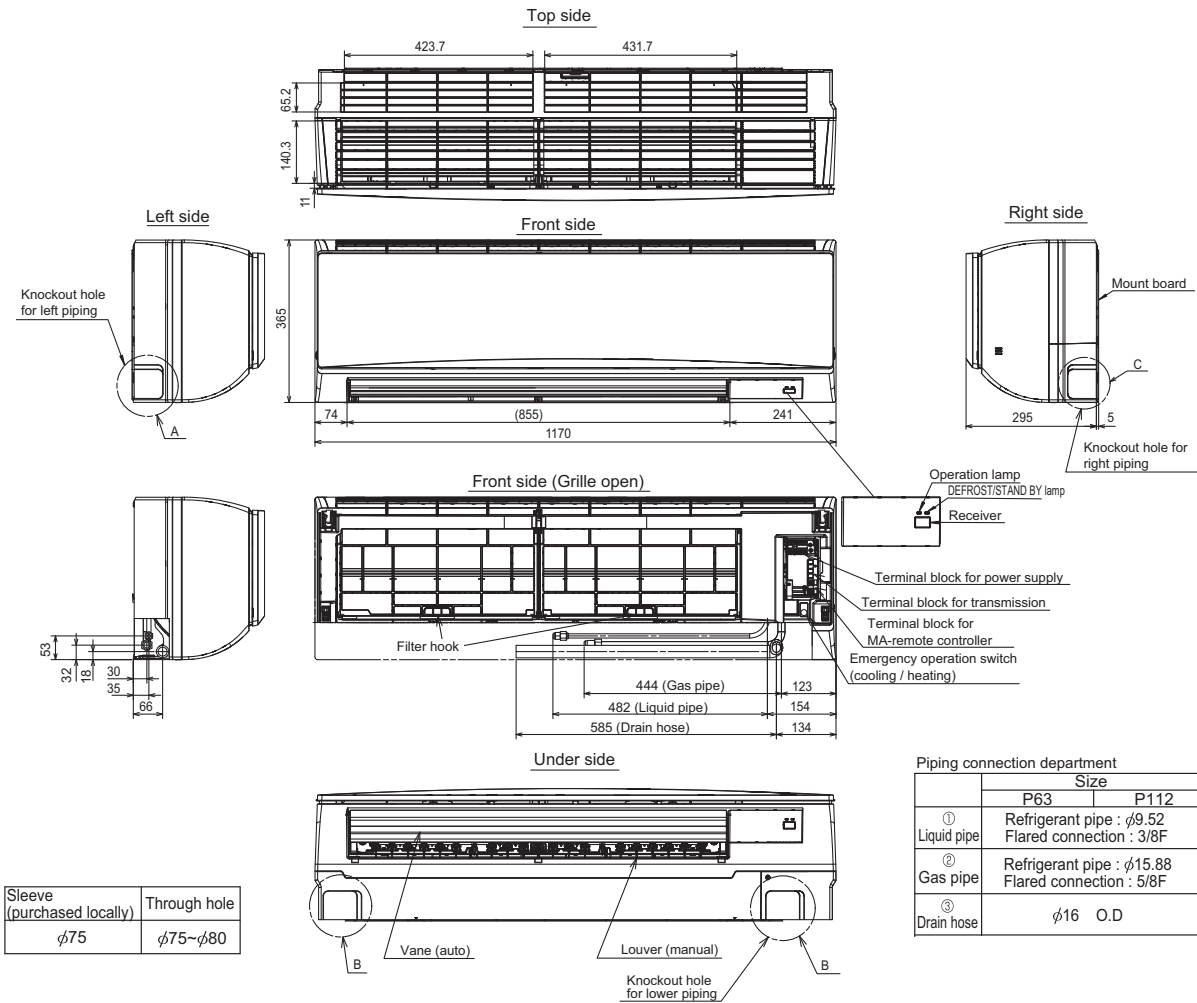

Sleeve (purchased locally)	Through hole
φ75	φ75~φ80

	Size	
	P63	P112
① Liquid pipe	Refrigerant pipe : φ9.52 Flared connection : 3/8F	
② Gas pipe	Refrigerant pipe : φ15.88 Flared connection : 5/8F	
③ Drain hose	φ16 O.D	

PKFY

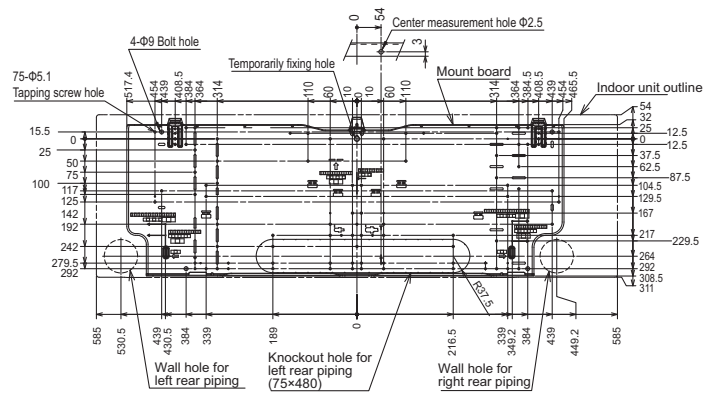
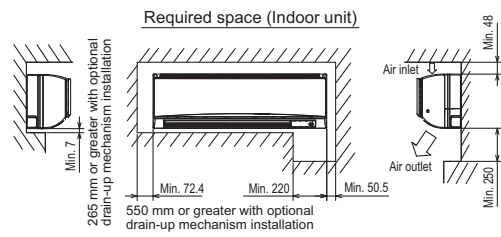
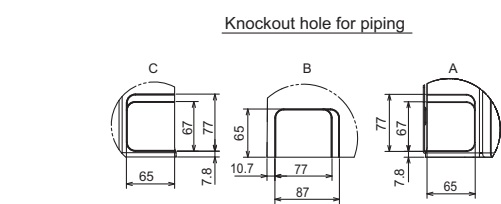

108 mm or greater with left or rear left piping or drain-up mechanism installation

PKFY-P-VBM-E, VHM-E, VKM-E

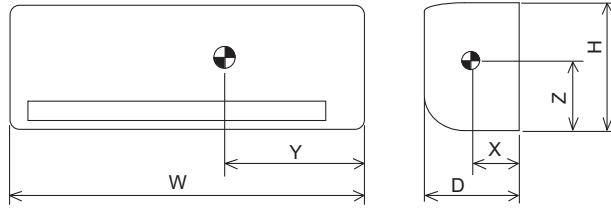

Model	W	D	H	X	Y	Z
PKFY-P15VBM-E	815	225	295	120	300	150
PKFY-P20VBM-E	815	225	295	120	300	150
PKFY-P25VBM-E	815	225	295	120	300	150
PKFY-P32VHM-E	898	249	295	120	390	160
PKFY-P40VHM-E	898	249	295	120	390	160
PKFY-P50VHM-E	898	249	295	120	390	160
PKFY-P63VKM-E	1170	295	365	190	460	190
PKFY-P100VKM-E	1170	295	365	190	460	190

PKFY-P15, 20, 25VBM-E

Legend

Symbol	Name	Symbol	Name	Symbol	Name
I.B	Indoor controller board	MV	Vane motor	SW5	Switch
CN32	Connector	LEV	Linear expansion valve	SW11	Address setting 1s digit
CN51	Centrally control	TB2	Terminal block	SW12	Address setting 10ths digit
CN52	Remote indication	TB5	Transmission	SW14	Connection No.
SW2	Switch	TH21	Thermistor	W.B	Wireless remote controller board
SW3	Capacity code	TH22	Room temp.detection (0°C/15kΩ,25°C/5.4kΩ)	RU	Receiving unit
	Mode selection	TH23	Pipe temp.detection/Liquid (0°C/15kΩ,25°C/5.4kΩ)	BZ	Buzzer
P.B	Indoor power board	TH23	Pipe temp.detection/Gas (0°C/15kΩ,25°C/5.4kΩ)	LED1	LED(Operation indicator:Green)
ZNR	Varistor	A.B	Address board	LED2	LED(Preparation for heating:Orange)
FUSE	Fuse (T6.3AL 250V)	SW1	Switch	SW1	Emergency operation (Heat)
F.C	Fan phase control			SW2	Emergency operation (Cool)
C1	Capacitor (Fan motor)				
MF	Fan motor				

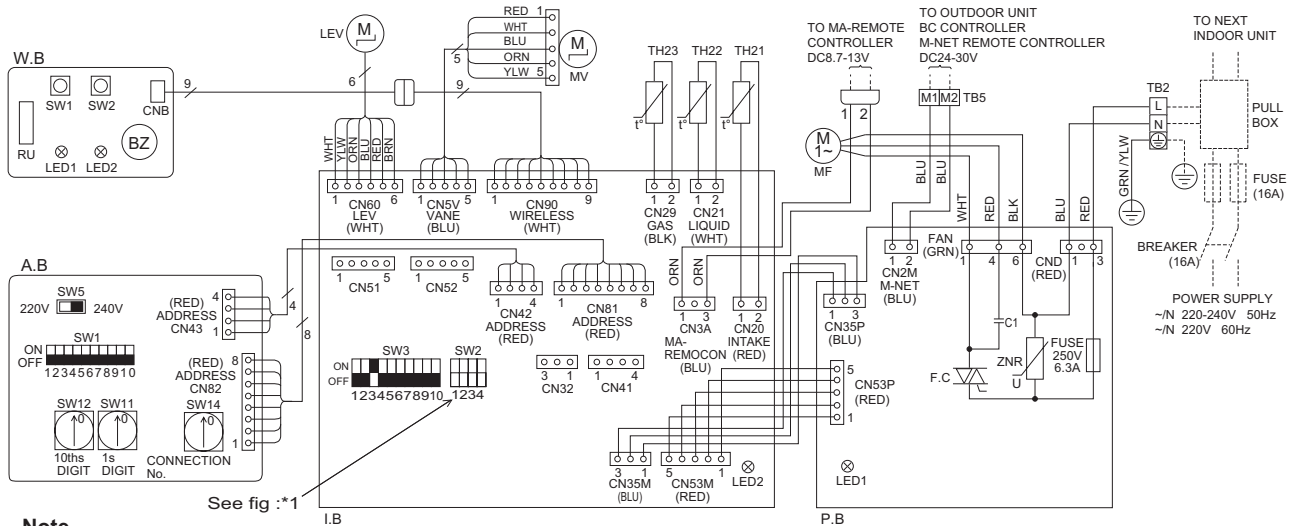

Note

- At servicing for outdoor unit, always follow the wiring diagram of outdoor unit.
- In case of using MA-remote controller, please connect MA-remote controller cable in an accessory to the connector (Remote controller wire is non-polar.)
- In case of using M-NET, please connect to TB5 (Transmission line is non-polar.)
- Symbols used in wiring diagram above are, : terminal block, : connector
- The setting of the SW2 dip switches differs in the capacity. For the detail, refer to the fig : *1.
- Please set the switch SW5 according to the power supply voltage.
Set SW5 to 240V side when the power supply is 230 and 240 volts.
When the power supply is 220 volts, set SW5 to 220V side.

LED on indoor board for service

Mark	Meaning	Function
LED1	Main power supply	Main power supply (indoor unit:220-240V) power on → lamp is lit
LED2	Power supply for MA-Remote controller	Power supply for MA-Remote controller on → lamp is lit

<*1>

MODELS	SW2	MODELS	SW2	MODELS	SW2
P15		P20		P25	

PKFY-P32, 40, 50VHM-E

SYMBOL	NAME	SYMBOL	NAME
I.B	INDOOR CONTROLLER BOARD	TH21	THERMISTOR ROOM TEMP. DETECTION (0°C/15kΩ, 25°C/5.4kΩ)
CN32	CONNECTOR REMOTE SWITCH	TH22	PIPE TEMP. DETECTION / LIQUID (0°C/15kΩ, 25°C/5.4kΩ)
CN51	CENTRALLY CONTROL	TH23	PIPE TEMP. DETECTION / GAS1 (0°C/15kΩ, 25°C/5.4kΩ)
CN52	REMOTE INDICATION	TH24	PIPE TEMP. DETECTION / GAS2 (0°C/15kΩ, 25°C/5.4kΩ)
BZ	BUZZER	A.B	ADDRESS BOARD
DSA	SURGE ABSORBER	SWA	SWITCH FAN SPEED SELECTOR
FUSE	FUSE (T3.15AL 250V)	SW1	MODE SELECTION
LED1	POWER SUPPLY (I.B)	SW11	ADDRESS SETTING 1s DIGIT
LED2	POWER SUPPLY (I.B)	SW12	ADDRESS SETTING 10ths DIGIT
SW2	SWITCH CAPACITY CODE	SW14	BRANCH No.
SW3	MODE SELECTION	S.B	SWITCH BOARD
SW4	MODEL SELECTOR	SWE1	EMERGENCY OPERATION(HEAT)
SWE	DRAIN PUMP (TEST MODE)	SWE2	EMERGENCY OPERATION(COOL)
X1	AUX.RELAY DRAIN PUMP (OPTION)	W.B	PCB FOR WIRELESS REMOTE CONTROLLER
MOV 01.02	VARIATOR	LED1	LED(OPERATION INDICATOR:GREEN)
LEV	LINEAR EXPANSION VALVE	LED2	LED(OPERATION FOR HEATING :ORANGE)
MF	FAN MOTOR	RU	RECEIVING UNIT
MV	VANE MOTOR	DP	DRAIN PUMP (OPTION)
TB2	TERMINAL POWER SUPPLY	FS	DRAIN FLOAT SWITCH (OPTION)
TB5	BLOCK TRANSMISSION		
TB15	MA-REMOTE CONTROLLER		

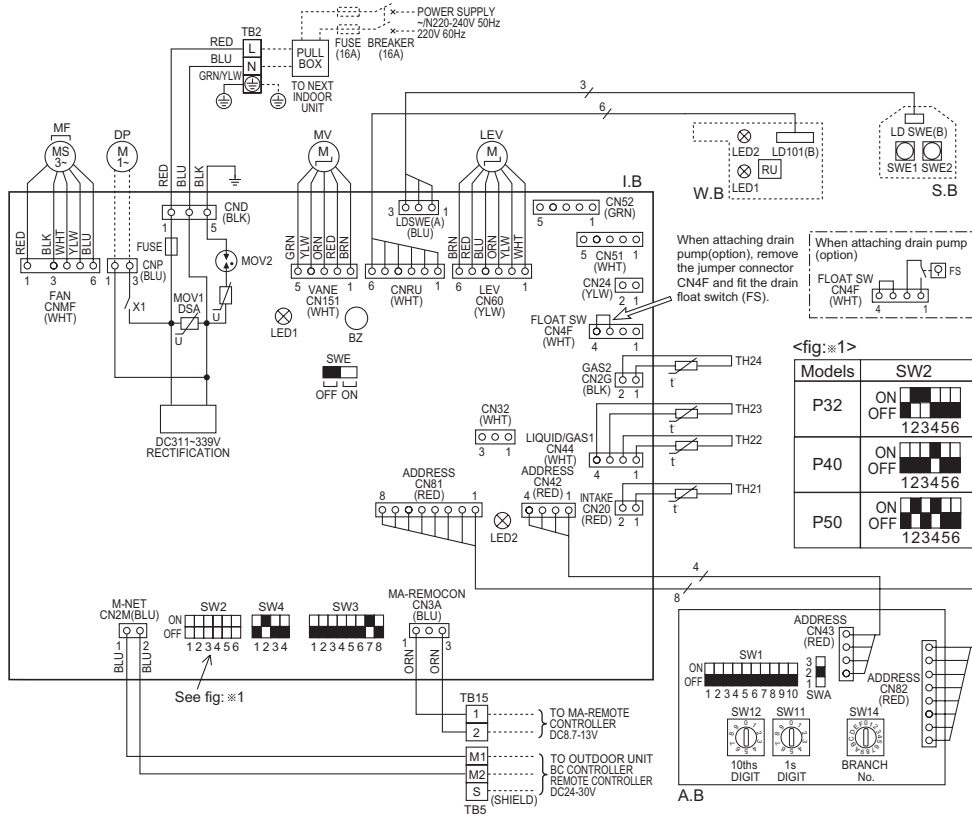

LED on indoor board for service

Mark	Meaning	Function
LED1	Main power supply	Main power supply (Indoor unit:220-240V) Power on → lamp is lit
LED2	Power supply for MA-Remote controller	Power supply for MA-Remote controller on → lamp is lit

NOTES:

- At servicing for outdoor unit, always follow the wiring diagram of outdoor unit.
- In case of using MA-Remote controller, please connect to TB15.
(Remote controller wire is non-polar.)
- In case of using M-NET, please connect to TB5. (Transmission line is non-polar.)
- Symbol [S] of TB5 is the shield wire connection.
- Symbols used in wiring diagram above are, [] : terminal block, [] : connector.
- The setting of the SW2 dip switches differs in the capacity. for the detail, refer to the fig. ※1.

PKFY

PKFY-P63, 100VKM-E

SYMBOL	NAME	SYMBOL	NAME
I.B	INDOOR CONTROLLER BOARD	TH21	THERMISTOR
CN32	CONNECTOR	TH22	ROOM TEMP. DETECTION (0°C/15kΩ, 25°C/5.4kΩ)
CN51	CENTRALLY CONTROL	TH23	PIPE TEMP. DETECTION / LIQUID (0°C/15kΩ, 25°C/5.4kΩ)
CN52	REMOTE SWITCH	TH24	PIPE TEMP. DETECTION / GAS1 (0°C/15kΩ, 25°C/5.4kΩ)
BZ	BUZZER		PIPE TEMP. DETECTION / GAS2 (0°C/15kΩ, 25°C/5.4kΩ)
DSA	SURGE ABSORBER	A.B	ADDRESS BOARD
FUSE	FUSE (T3.15A/250V)	SWA	SWITCH
LED1	POWER SUPPLY (I.B)	SW1	FAN SPEED SELECTOR
LED2	POWER SUPPLY (I.B)	SW11	MODE SELECTION
SW2	SWITCH	SW12	ADDRESS SETTING 1s DIGIT
SW3	CAPACITY CODE	SW14	ADDRESS SETTING 10ths DIGIT
SW4	MODE SELECTION		BRANCH No.
SW6	MODEL SELECTOR	S.B	SWITCH BOARD
SWE	DRAIN PUMP (TEST MODE)	SWE1	EMERGENCY OPERATION(HEAT)
X1	AUX.RELAY	SWE2	EMERGENCY OPERATION(COOL)
MOV 01.02	VARISTOR	W.B	PCB FOR WIRELESS REMOTE CONTROLLER
LEV	LINEAR EXPANSION VALVE	LED1	LED(OPERATION INDICATOR:GREEN)
MF	FAN MOTOR	LED2	LED(OPERATION FOR HEATING :ORANGE)
MV	VANE MOTOR	RU	RECEIVING UNIT
TB2	TERMINAL	DP	DRAIN PUMP (OPTION)
TB5	BLOCK	FS	DRAIN FLOAT SWITCH (OPTION)
TB15	TRANSMISSION		
	MA-REMOTE CONTROLLER		

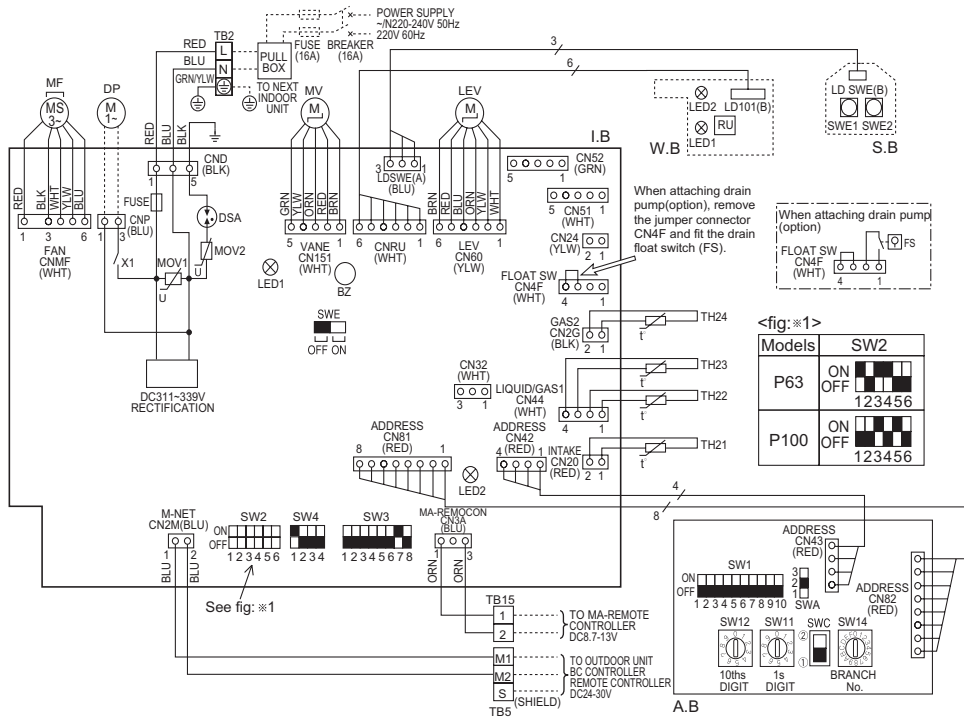

LED on indoor board for service

Mark	Meaning	Function
LED1	Main power supply	Main power supply (Indoor unit:220-240V) Power on → lamp is lit
LED2	Power supply for MA-Remote controller	Power supply for MA-Remote controller on → lamp is lit

NOTES:

- At servicing for outdoor unit, always follow the wiring diagram of outdoor unit.
- In case of using MA-Remote controller, please connect to TB15.
(Remote controller wire is non-polar.)
- In case of using M-NET, please connect to TB5. (Transmission line is non-polar.)
- Symbol [S] of TB5 is the shield wire connection.
- Symbols used in wiring diagram above are, : terminal block, : connector.
- The setting of the SW2 dip switches differs in the capacity. for the detail, refer to the fig:※1.

5-1. Sound levels

Wall mounted

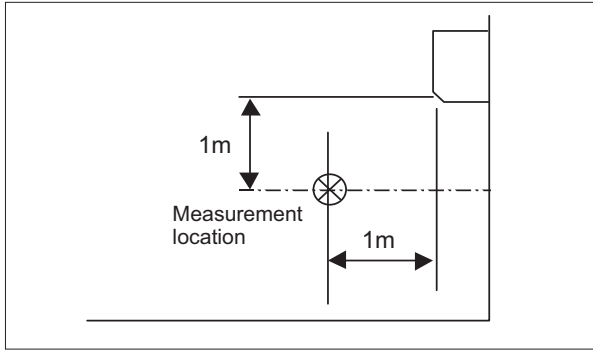

Sound level at anechoic room : Low-(Middle2-Middle)-High

Model	Sound level dB (A)
PKFY-P15VBM-E	29-31-32-33
PKFY-P20VBM-E PKFY-P25VBM-E	29-31-34-36
PKFY-P32VHM-E	34-37-41
PKFY-P40VHM-E	34-38-41
PKFY-P50VHM-E	34-39-43
PKFY-P63VKM-E	39-45
PKFY-P100VKM-E	41-49

* Measured in anechoic room.

5-2. NC curves

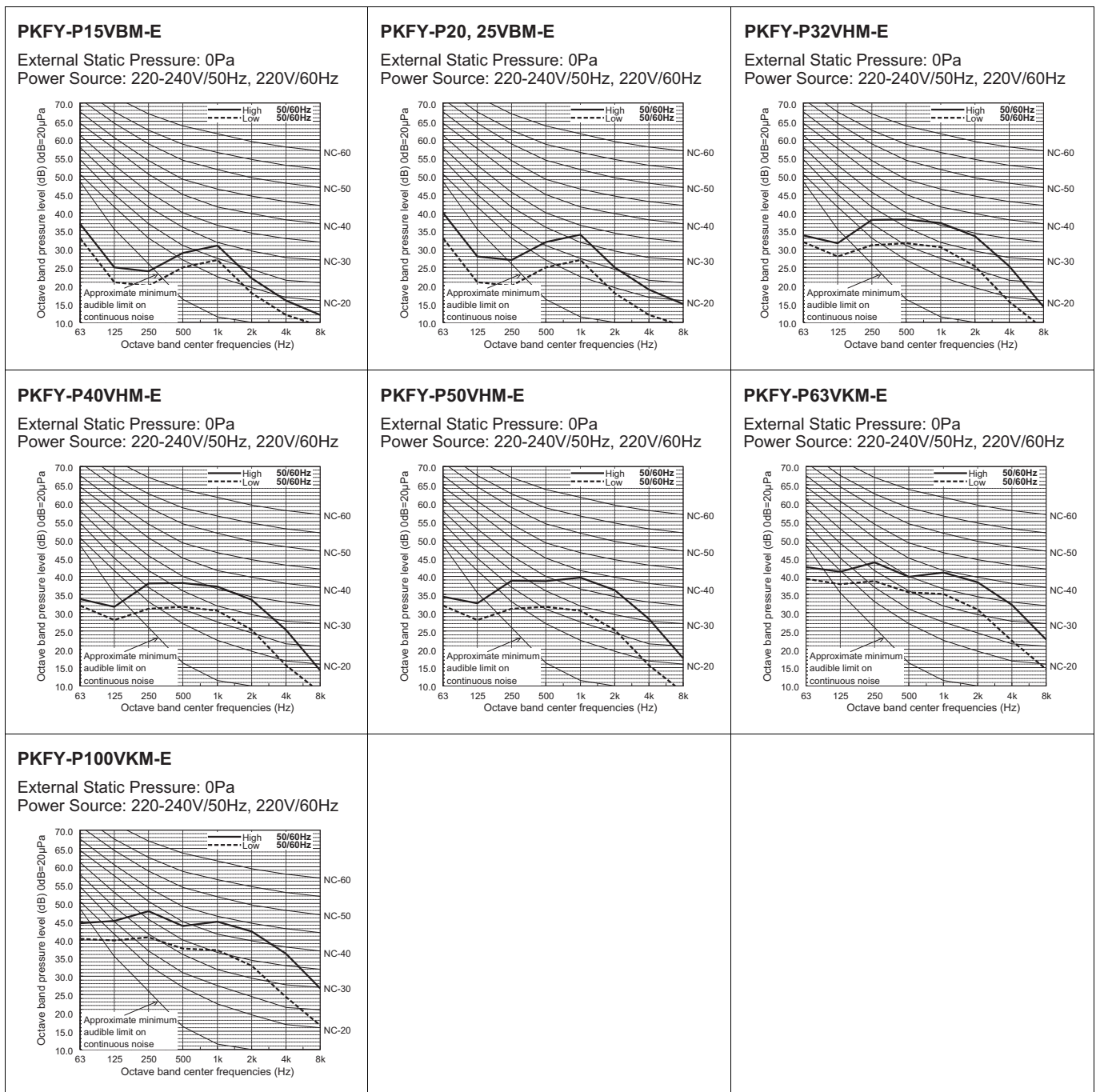

PKFY

6-1. Temperature distributions

PKFY-P15-25VBM-E

<Cooling mode>
Horizontal air flow



<Heating mode>
Downward air flow

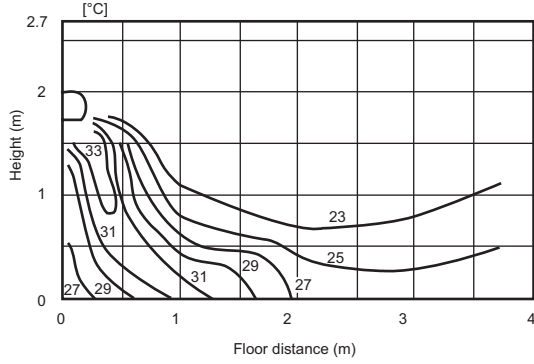

PKFY-P32-50VHM-E

<Cooling mode>
Horizontal air flow

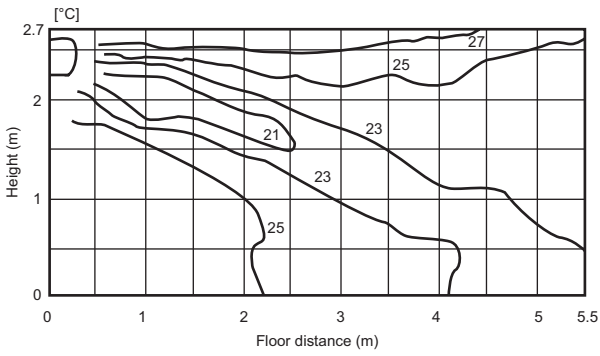

<Heating mode>
Downward air flow

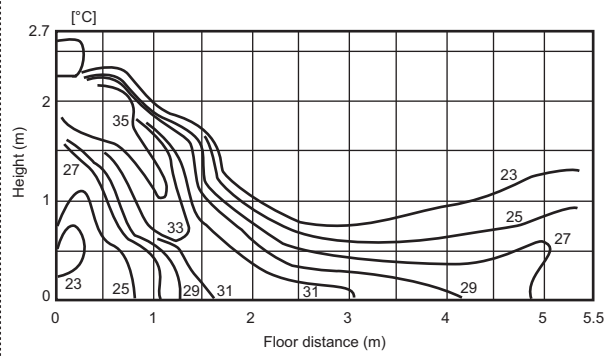

PKFY-P63, 100VKM-E

<Cooling mode>
Horizontal air flow

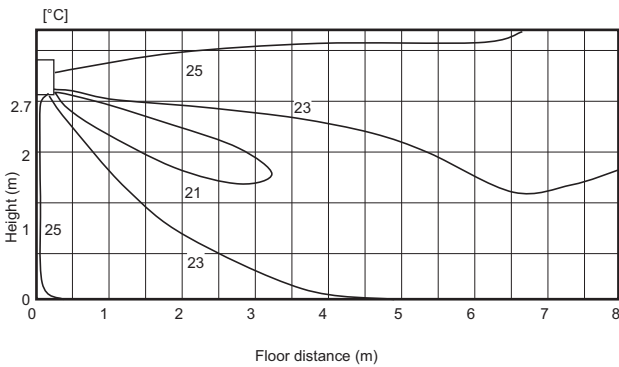

<Heating mode>
Downward air flow

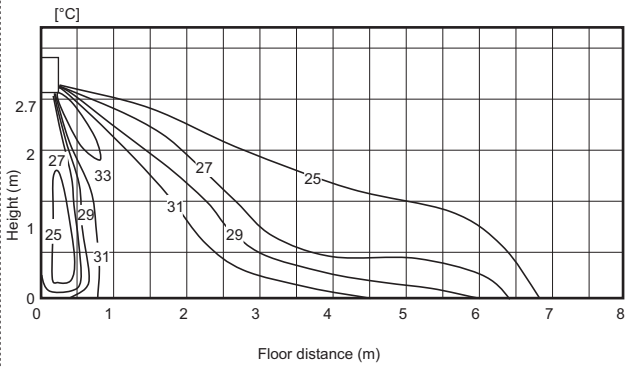

Note : These figures show typical temperature distributions in the conditions above. In the actual installation, they may differ from these figures under the influence of air temperature conditions, ceiling height, cooling/heating load, obstacles, etc.

PKFY

6-2. Airflow distributions

PKFY-P15-25VBM-E

<Fan mode>
Horizontal air flow

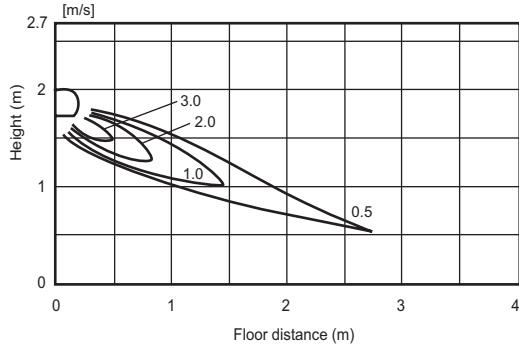

<Fan mode>
Downward air flow

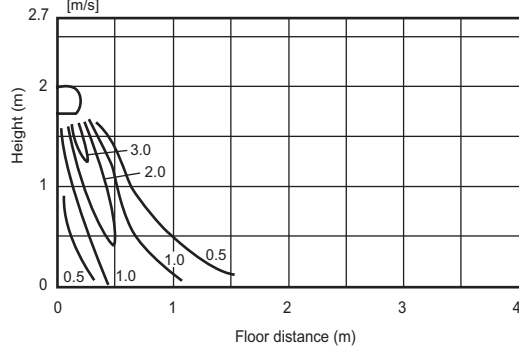

PKFY-P32-50VHM-E

<Fan mode>
Horizontal air flow

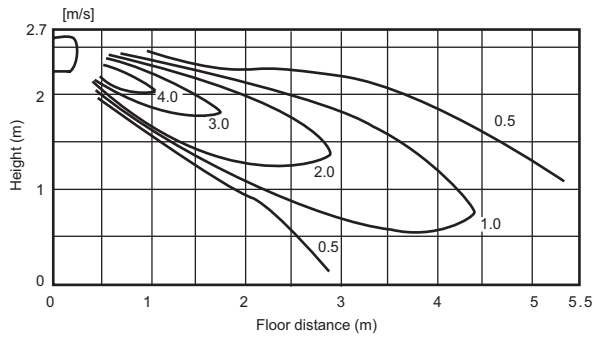

<Fan mode>
Downward air flow

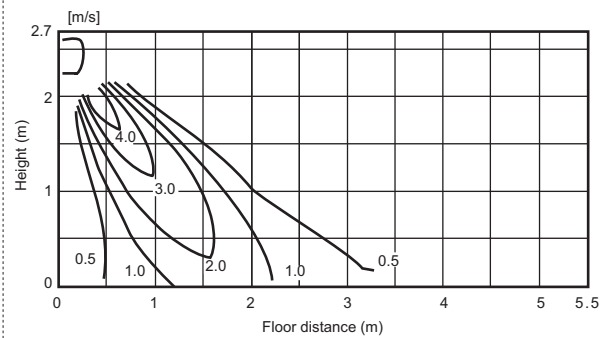

PKFY-P63, 100VKM-E

<Fan mode>
Horizontal air flow

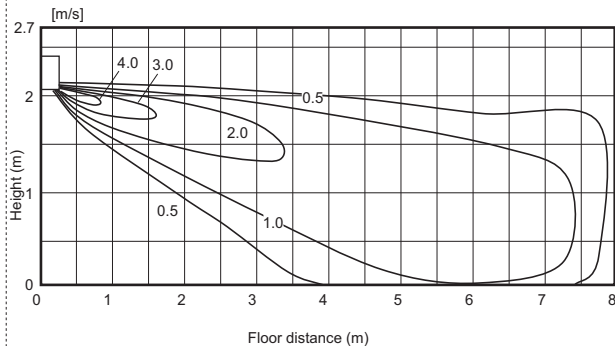

<Fan mode>
Downward air flow

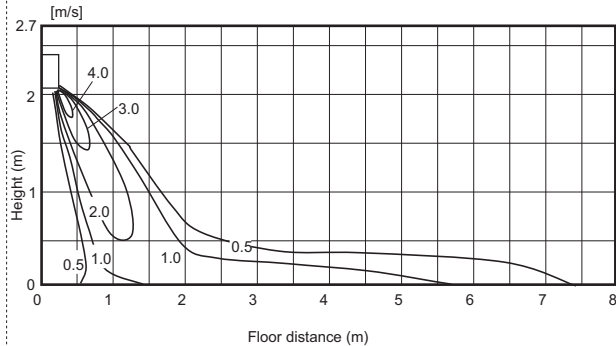



Note : These figures show typical airflow distributions in the conditions above. In the actual installation, they may differ from these figures under the influence of air temperature conditions, ceiling height, cooling/heating load, obstacles, etc.

PKFY

7-1. Optional parts line up for the Indoor unit

	External LEV Box	Drain pump
PKFY-P15, 20, 25VBM-E	PAC-SG95LE-E	—
PKFY-P32, 40, 50VHM-E	—	PAC-SH75DM-E
PKFY-P63, 100VKM-E	—	PAC-SH94DM-E

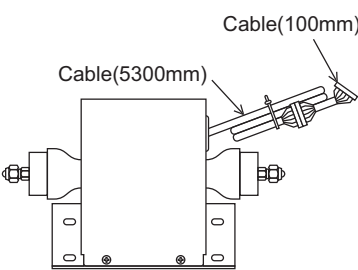
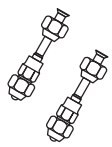
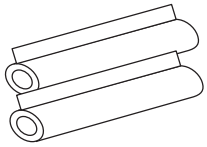
7-2. External LEV Box

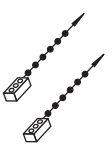

Item	① External LEV Box	② Joint pipe	③ Pipe cover	④ Band	⑤ Fastener
Quantity	1	2	2	2	2
Shape					

Detailed installation information should be referred to its Installation Manual (RG79A417K01)

7-3. Drain pump

PAC-SH75DM-E

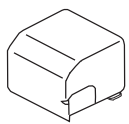

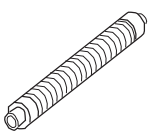
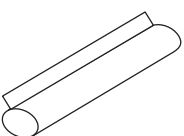
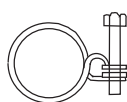
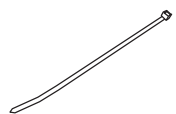
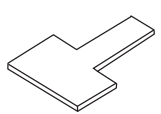
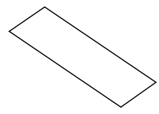
If drain water can not flow out the Indoor unit by gravity and gradient, a Drain-pump for draining is needed. Drain pump PAC-SH75DM-E can pump water up to 800mm high from the drain pan.

Item	① Drain pump	② Screw	③ Drain hose	④ Drain hose cover	⑤ Hose band
Quantity	1	(M4×16)×1, (M4×35)×6	1	1	1
Shape					
Item	⑥ Band	⑦ Installation plate	⑧ Wiring diagram		
Quantity	1	1	1		
Shape					

Detailed installation information should be referred to its Installation Manual (RG79Y375H01)

PAC-SH94DM-E

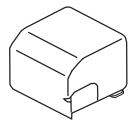
If drain water can not flow out the Indoor unit by gravity and gradient, a Drain-pump for draining is needed. Drain pump PAC-SH94DM-E can pump water up to 800mm high from the drain pan.

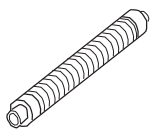
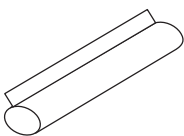
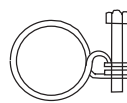
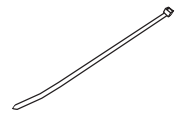
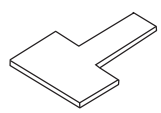
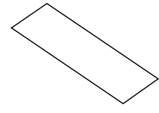
Item	① Drain pump	② Screw	③ Drain hose	④ Drain hose cover	⑤ Hose band
Quantity	1	(M4×16)×1, (M4×35)×6	1	1	1
Shape					
Item	⑥ Band	⑦ Installation plate	⑧ Wiring diagram		
Quantity	1	1	1		
Shape					

Detailed installation information should be referred to its Installation Manual (RG79Y376H01)