



PKFY-P-VBM-E



PKFY-P-VGM-E

**PKFY-P-VBM-E
PKFY-P-VGM-E
PKFY-P-VFM-E**



PKFY-P-VFM-E

1. SPECIFICATIONS	IU-G- 2
2. EXTERNAL DIMENSIONS	IU-G- 4
3. ELECTRICAL WIRING DIAGRAMS	IU-G- 7
4. SOUND LEVELS	
4-1. Sound levels	IU-G- 10
4-2. NC curves	IU-G- 10
5. TEMPERATURE/AIRFLOW DISTRIBUTIONS	
5-1. Temperature distributions	IU-G- 11
5-2. Airflow distributions	IU-G- 12
6. Optional parts for PKFY-P-VBM-E	IU-G- 13

Wall mounted	P20	P25	P32	P40	P50	P63	P71	P80	P100	P125	P140	P200	P250
	0.8HP	1.0HP	1.3HP	1.6HP	2.0HP	2.5HP	2.8HP	3.2HP	4.0HP	5.0HP	5.6HP	8.0HP	10.0HP
PKFY-P-VBM-E	●	●											
PKFY-P-VGM-E			●	●	●								
PKFY-P-VFM-E						●							

1. SPECIFICATIONS

R410A Data G4

Model		PKFY-P20VBM-E	PKFY-P25VBM-E	PKFY-P32VGM-E	PKFY-P40VGM-E	PKFY-P50VGM-E		
Power source		1-phase 220-240V 50Hz, 1-phase 220V 60Hz						
Cooling capacity (Nominal)	*1 kW	2.2	2.8	3.6	4.5	5.6		
	*1 kcal / h	1,900	2,400	3,100	3,900	4,800		
	*1 Btu / h	7,500	9,600	12,300	15,400	19,100		
	*2 kcal / h	2,000	2,500	3,150	4,000	5,000		
	Power input	kW	0.04	0.04	0.07	0.07	0.07	
	Current input	A	0.20	0.20	0.32	0.32	0.32	
Heating capacity (Nominal)	*3 kW	2.5	3.2	4.0	5.0	6.3		
	*3 kcal / h	2,200	2,800	3,400	4,300	5,400		
	*3 Btu / h	8,500	10,900	13,600	17,100	21,500		
	Power input	kW	0.04	0.04	0.07	0.07	0.07	
	Current input	A	0.20	0.20	0.32	0.32	0.32	
External finish		Plastic, MUNSELL (1.0Y 9.2/0.2)						
External dimension H x W x D		mm	295 x 815 x 225	295 x 815 x 225	340 x 990 x 235	340 x 990 x 235	340 x 990 x 235	
		in.	11-5/8" x 32-1/8" x 8-7/8"	11-5/8" x 32-1/8" x 8-7/8"	13-7/16" x 39" x 9-5/16"	13-7/16" x 39" x 9-5/16"	13-7/16" x 39" x 9-5/16"	
Net weight		kg (lb)	10 (23)	10 (23)	16 (36)	16 (36)	16 (36)	
Heat exchanger		Cross fin (Aluminum fin and copper tube)						
FAN	Type x Quantity		Line flow fan x 1	Line flow fan x 1	Line flow fan x 1	Line flow fan x 1	Line flow fan x 1	
	External static press.	Pa	0	0	0	0	0	
		mmH ₂ O	0	0	0	0	0	
	Motor type		1-phase induction motor					
	Motor output		kW	0.017	0.017	0.030	0.030	0.030
	Driving mechanism		Direct-driven by motor					
	Airflow rate (Low-Mid-High)	m ³ / min	4.9 - 5.2 - 5.6 - 5.9	4.9 - 5.2 - 5.6 - 5.9	8 - 9.5 - 10.5 - 11.5	8 - 9.5 - 10.5 - 11.5	9 - 10 - 11 - 12	
L / s		82 - 87 - 93 - 98	82 - 87 - 93 - 98	133 - 158 - 175 - 192	133 - 158 - 175 - 192	150 - 167 - 183 - 200		
		cfm	173 - 184 - 198 - 208	173 - 184 - 198 - 208	283 - 335 - 371 - 406	283 - 335 - 371 - 406	318 - 353 - 388 - 424	
Noise level (Low-High) (measured in anechoic room)		dB <A>	29 - 31 - 34 - 36	29 - 31 - 34 - 36	33 - 36 - 38 - 41	33 - 36 - 38 - 41	34 - 37 - 40 - 43	
Insulation material		Polyester sheet						
Air filter		PP honeycomb						
Protection device		Fuse						
Refrigerant control device		LEV						
Connectable outdoor unit		R410A, R407C, R22 CITY MULTI						
Diameter of refrigerant pipe	Liquid (R410A) (R22, R407C)	mm (in.)	ø6.35 (ø1/4") Flare	ø6.35 (ø1/4") Flare	ø6.35 (ø1/4") Flare	ø6.35 (ø1/4") Flare	ø6.35 (ø1/4") Flare	
			ø6.35 (ø1/4") Flare	ø6.35 (ø1/4") Flare	ø6.35 (ø1/4") Flare	ø6.35 (ø1/4") Flare	ø9.52 (ø3/8") Flare	
	Gas (R410A) (R22, R407C)	mm (in.)	ø12.7 (ø1/2") Flare	ø12.7 (ø1/2") Flare	ø12.7 (ø1/2") Flare	ø12.7 (ø1/2") Flare	ø12.7 (ø1/2") Flare	ø15.88 (ø5/8") Flare
Field drain pipe size		mm (in.)	I.D. 16mm (5/8")	I.D. 16mm (5/8")	I.D. 20mm (13/16")	I.D. 20mm (13/16")	I.D. 20mm (13/16")	
Drawing	External					IU-RG01-N630		
	Wiring					IU-RG79-N550		
	Refrigerant cycle					-		
Standard attachment		Document Accessory					Installation Manual, Instruction Book	
Remark	Optional parts							
	External LEV Box		PAC-SG95LE-E□ (for□ PKFY-F-VBM-E□ only)					
Installation		Details on foundation work, duct work, insulation work, electrical wiring, power source switch, and other items shall be referred to the Installation Manual.						

Note :

*1 Nominal cooling conditions	*2 Nominal cooling conditions	*3 Nominal heating conditions	Unit converter
Indoor : 27°CDB/19°CWB (81°FDB/66°FWB)	27°CDB/19.5°CWB (81°FDB/67°FWB)	20°CDB (68°FDB)	kcal/h = kW x 860
Outdoor : 35°CDB (95°FDB)	35°CDB (95°FDB)	7°CDB/6°CWB (45°FDB/43°FWB)	Btu/h = kW x 3,412
Pipe length : 7.5 m (24-9/16 ft)	5 m (16-3/8 ft)	7.5 m (24-9/16 ft)	cfm = m ³ /min x 35.31
Level difference : 0 m (0 ft)	0 m (0 ft)	0 m (0 ft)	lb = kg / 0.4536

* Nominal conditions *1, *3 are subject to JIS B8615-1.
 * Due to continuing improvement, above specification may be subject to change without notice.

*Above specification data is subject to rounding variation.

1. SPECIFICATIONS

Model		PKFY-P63VFM-E			
Power source		1-phase 220-240V 50Hz, 220V 60Hz			
Cooling capacity (Nominal)	*1	kW	7.1		
	*1	kcal / h	6,100		
	*1	Btu / h	24,200		
	*2	kcal / h	6,300		
	Power input	kW	0.12		
	Current input	A	0.55		
Heating capacity (Nominal)	*3	kW	8.0		
	*3	kcal / h	6,900		
	*3	Btu / h	27,300		
	Power input	kW	0.12		
	Current input	A	0.55		
External finish		Plastic, White MUNSELL (3.4Y 7.7/0.8)			
External dimension H x W x D	mm	340x1,400x235			
	in.	13-7/16" x 55-1/8" x 9-5/16"			
Net weight	kg (lb)	24 (53 lb)			
Heat exchanger		Cross fin (Aluminum fin and copper tube)			
FAN	Type x Quantity		Line flow fan x 2		
	External static press.	Pa	0		
		mmH ₂ O	0		
	Motor type		1-phase induction motor		
	Motor output	kW	0.040		
	Driving mechanism		Direct-driven by motor		
	Airflow rate (Low-Mid-High)	m ³ / min	15-20		
L / s		250-333			
cfm		530-706			
Noise level (Low-Mid-High) (measured in anechoic room)	dB <A>	39-45			
Insulation material		Polyethylene sheet			
Air filter		PP honeycomb fabric			
Protection device		Fuse			
Refrigerant control device		LEV			
Connectable outdoor unit		R410A, R407C, R22 CITY MULTI			
Diameter of refrigerant pipe	Liquid (R410A) (R22, R407C)	mm (in.)	ø9.52 (ø3/8") Flare		
	Gas (R410A) (R22, R407C)	mm (in.)	ø15.88 (ø5/8") Flare ø15.88 (ø5/8") Flare		
Field drain pipe size	mm (in.)	I.D. 20mm (13/16")			
Drawing	External		IU-RG01V219		
	Wiring		IU-RG79V059		
	Refrigerant cycle		-		
Standard attachment	Document	Installation Manual, Instruction Book			
	Accessory				
Remark	Optional parts				
	Installation	Details on foundation work, duct work, insulation work, electrical wiring, power source switch, and other items shall be referred to the Installation Manual.			
Note :		*:1 Nominal cooling conditions	*:2 Nominal cooling conditions	*:3 Nominal heating conditions	Unit converter
Indoor :	27°CDB/19°CWB (81°FDB/66°FWB)	27°CDB/19.5°CWB (81°FDB/67°FWB)	20°CDB (68°FDB)	kcal/h = kW x 860	
Outdoor :	35°CDB (95°FDB)	35°CDB (95°FDB)	7°CDB/6°CWB (45°FDB/43°FWB)	Btu/h = kW x 3,412	
Pipe length :	7.5 m (24-9/16 ft)	5 m (16-3/8 ft)	7.5 m (24-9/16 ft)	cfm = m ³ /min x 35.31	
Level difference :	0 m (0 ft)	0 m (0 ft)	0 m (0 ft)	lb = kg / 0.4536	
* Nominal conditions *:1, *:3 are subject to JIS B8615-1.					*Above specification data is subject to rounding variation.
* Due to continuing improvement, above specification may be subject to change without notice.					

PKFY-P20, 25VBM-E

Unit : mm

Detail of installation plate

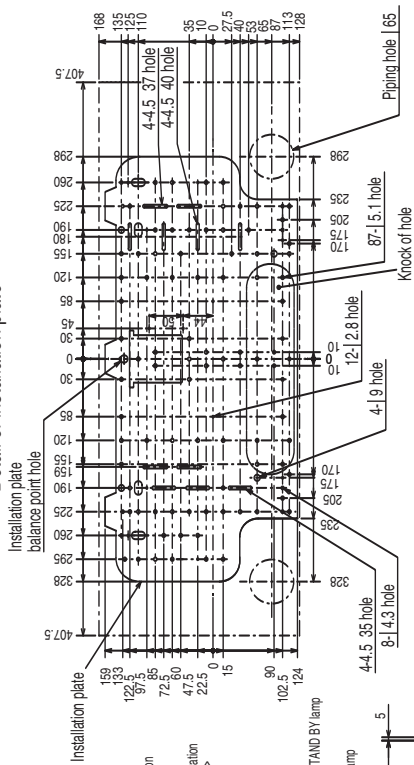

Installation space

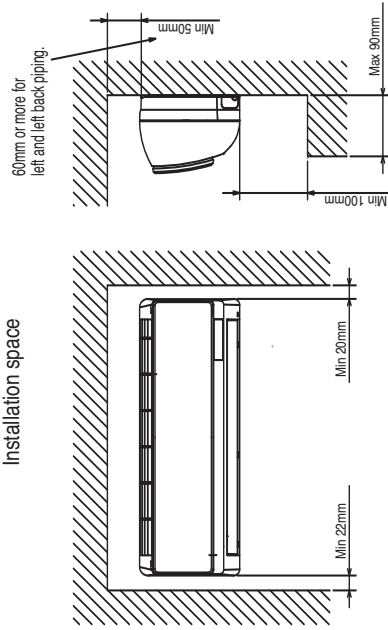

Note.1 Use M10 or W38 screw for installation plate.
 Note.2 Extension piping side.
 Note.3 In case of connecting MA-remote controller, please connect MA-remote controller cable (accessory) to the connector.

Refrigerant piping	Liquid pipe	1/4F (6.35)
	Gas pipe	1/2F (12.7)
Drain pipe		1 1/6 (I.D)

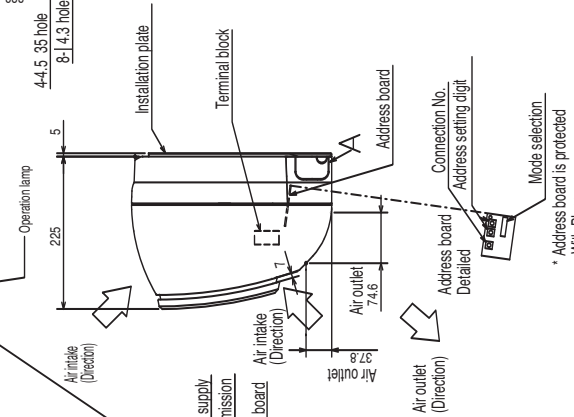
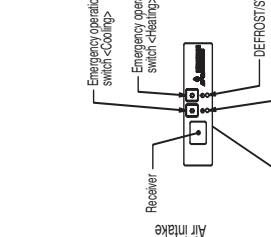

* Address board is protected with PL cover. Remove the screw with driver on the occasion of setting.

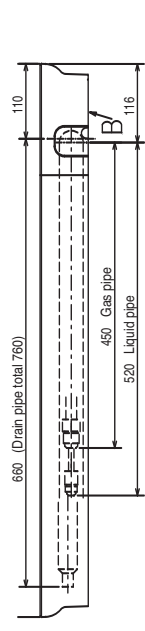
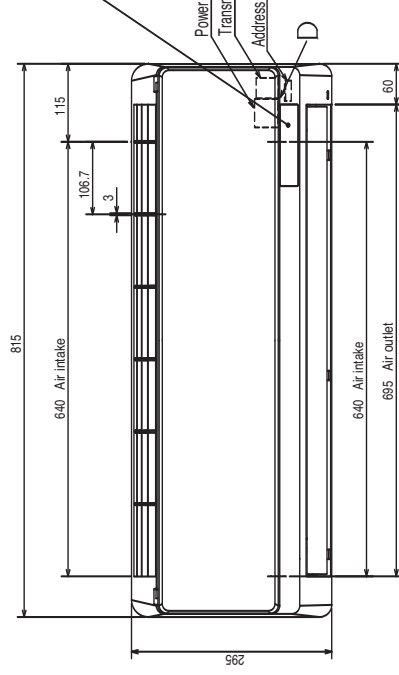
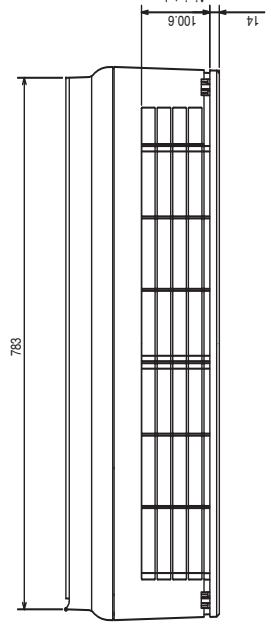

Detailed figure dwg(A BC) (Knock out hole)

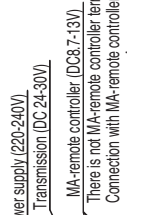
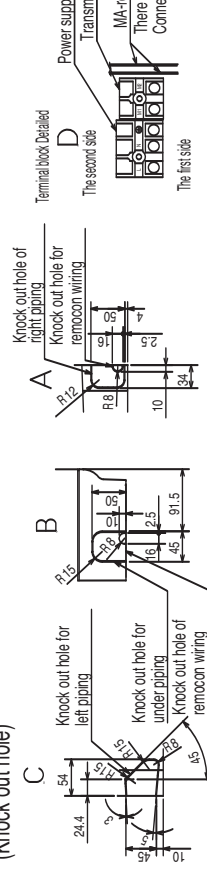

2. EXTERNAL DIMENSIONS

PKFY-P32,40,50VGM-E

Drw. : IU-RG01-N630
Unit : mm

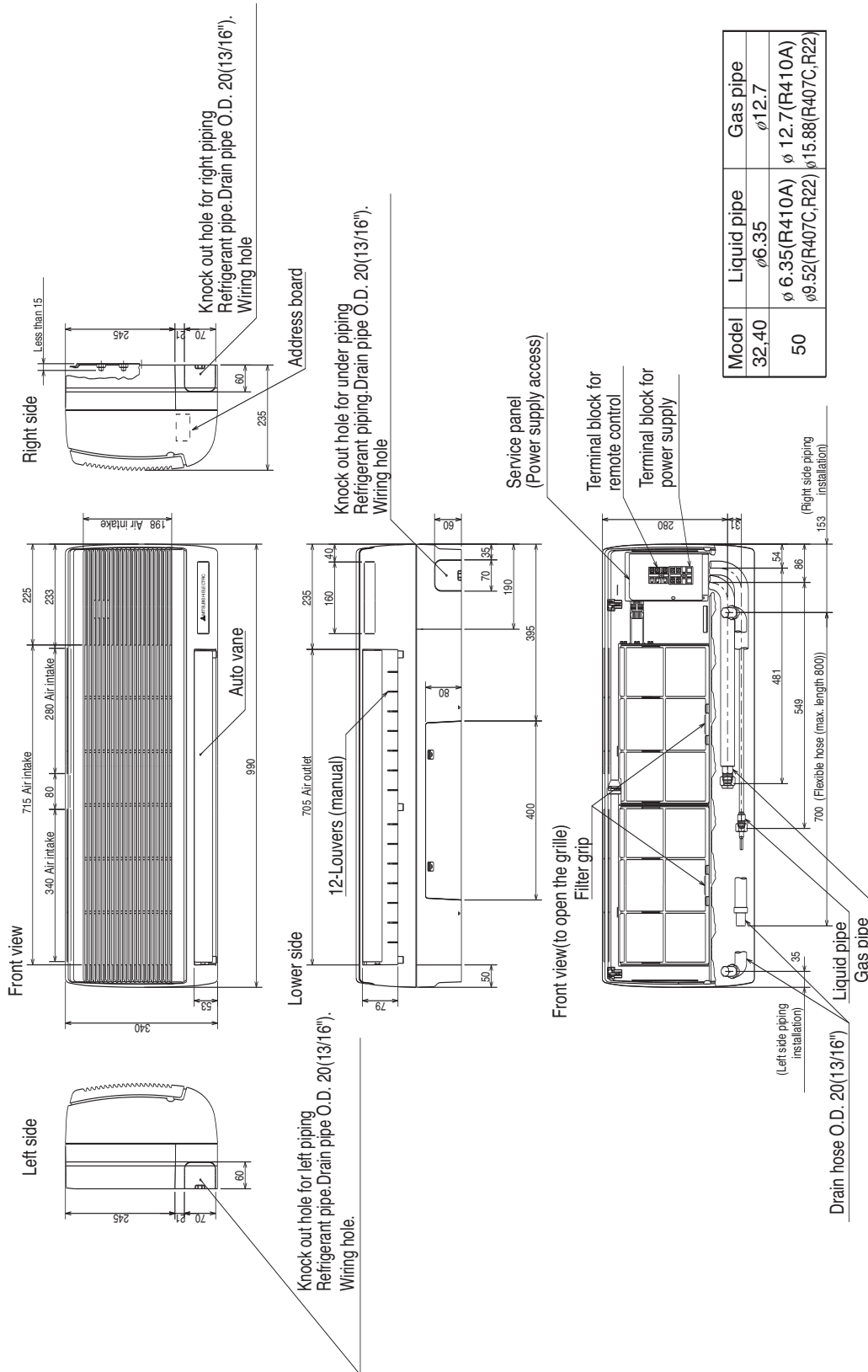

PKFY-P20,25VBM-E

Drw. : IU-RG79V612H01

Legend

Symbol	Name	Symbol	Name	Symbol	Name
I.B	Indoor controller board	MV	Vane motor	SW5	Switch
CN32	Connector	LEV	Linear expansion valve	SW11	Voltage selection
CN51	Connector	TB2	Terminal block	SW12	Address setting 1st digit
CN52	Connector	TB5	Terminal block	SW14	Address setting 2nd digit
SW2	Switch	TH21	Thermistor	SW14	Connection No.
SW3	Switch	TH21	Thermistor	W.B	Wireless remote controller board
P.B	Indoor power board	TH22	Thermistor	RU	Receiving unit
ZNR	Varistor	TH22	Thermistor	BZ	Buzzer
FUSE	Fuse (6.3A 250V)	TH23	Thermistor	LED1	LED(Operation indicator:Green)
F.C	Fan phase control	TH23	Thermistor	LED2	LED(Preparation for heating:Orange)
C1	Capacitor (fan motor)	A.B	Address board	SW1	Emergency operation (Heat)
MF	Fan motor	SW1	Switch	SW2	Emergency operation (Cool)

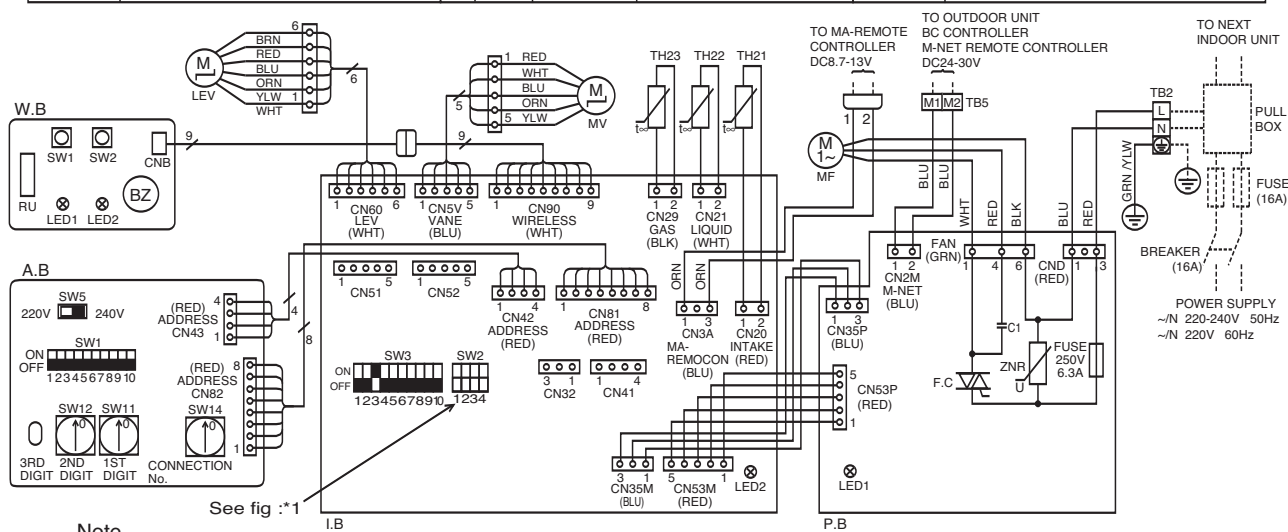

Note

- At servicing for outdoor unit, always follow the wiring diagram of outdoor unit.
- In case of connecting MA-remote controller, please connect MA remote controller cable in an accessory to the connector (Remote controller wire is non-polar.)
- In case of using M-NET, please connect to TB5 (Transmission line is non-polar.)
- Symbols used in wiring diagram above are, : terminal block, : connector
- The setting of the SW2 dip switches differs in the capacity. For the detail, refer to the fig : *1.
- Please set the switch SW2 according to the power supply voltage.
Set SW5 to 240V side when the power supply is 230 and 240 volts.
When the power supply is 220 volts, set SW5 to 220V side.

LED on indoor board for service

Mark	Meaning	Function
LED1	Main power supply	Main power supply (indoor unit:220-240V) power on → lamp is lit
LED2	Power supply for MA Remote controller	Power supply for MA Remote controller on → lamp is lit

<*1>

MODELS	SW2	MODELS	SW2
P20	ON OFF	P25	ON OFF

PKFY-P32,40,50VGM-E

Drw. : IU-RG79-N550

<SYMBOL EXPLANATION>

Symbol	Name	Symbol	Name	Symbol	Name	
I.B	Indoor controller board	TH21	Thermistor	A.B	Circuit board	
CN32	Connector	TH22		SW1	Mode selection	
CN41	Remote switch	TH23		SW5	Voltage selection	
CN51	Centrally control		SW11	Address setting 1st digit		
CN52	Remote indication		SW12	Address setting 2nd digit		
SW2	Switch	MF	Fan motor (with inner thermostat)	SW14	Connection No.	
SW3	Capacity code	C1	Capacitor (fan motor)	SWC	Option selector	
SW4	Mode selection	P.B	Indoor power board			
ZNR	Varistor	MV	Vane motor			
X4	Aux.Relay (Fan motor)	TB2	Terminal block			
FUSE	Fuse (6.3A)	TB5		Power supply		
F.C	Fan phase control	TB15		Transmission		
		LEV	Linear expansion valve			

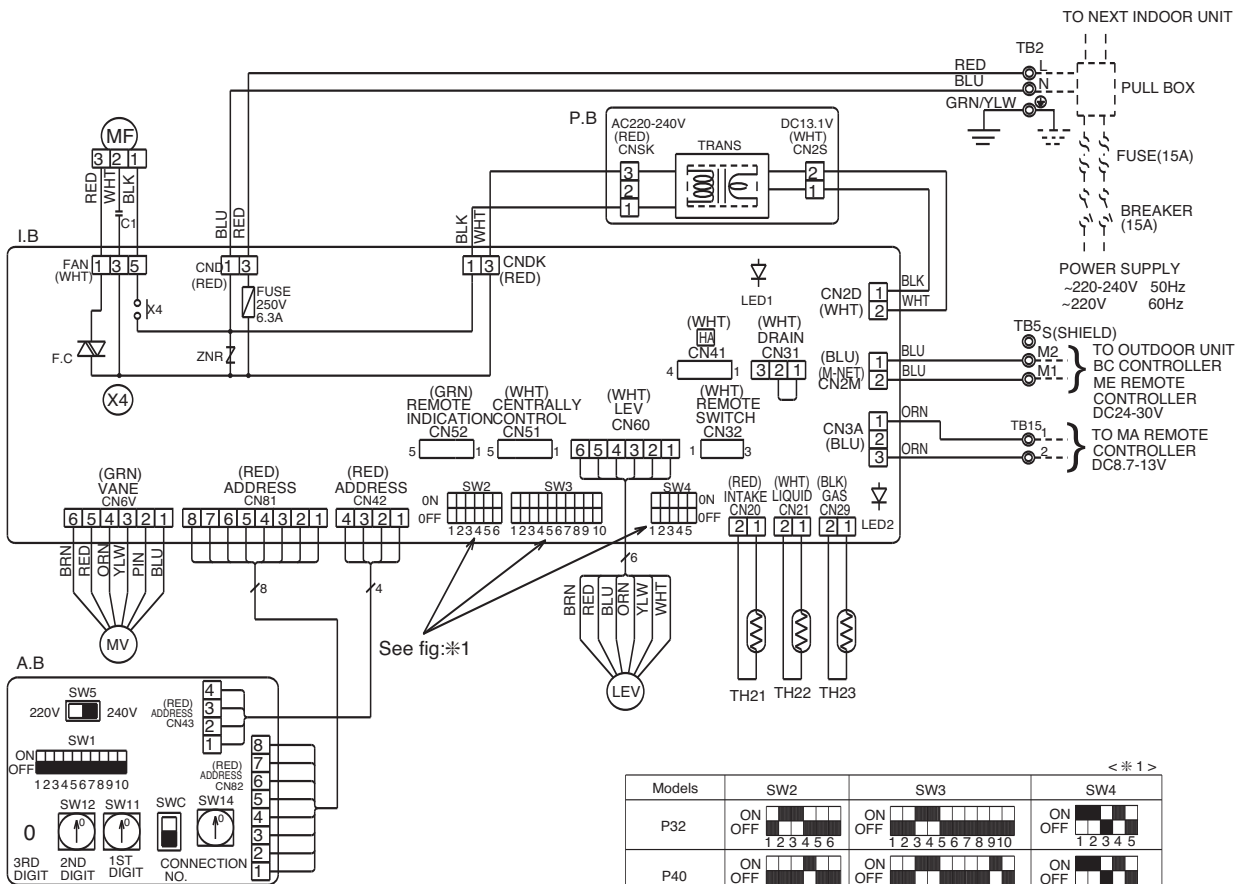

< * 1 >

Models	SW2	SW3	SW4
P32	ON OFF 1 2 3 4 5 6	ON OFF 1 2 3 4 5 6 7 8 9 10	ON OFF 1 2 3 4 5
P40	ON OFF 1 2 3 4 5 6	ON OFF 1 2 3 4 5 6 7 8 9 10	ON OFF 1 2 3 4 5
P50	ON OFF 1 2 3 4 5 6	ON OFF 1 2 3 4 5 6 7 8 9 10	ON OFF 1 2 3 4 5

NOTE

- At servicing for outdoor unit, always follow the wiring diagram of outdoor unit.
- In case of using MA Remote controller, please connect to TB15.
(Remote controller wire is non-polar.)
- In case of using M-NET, please connect to TB5. (Transmission line is non-polar.)
- Symbol [S] of TB5 is the shield wire connection.
- Symbols used in wiring diagram above are,
⊙: Terminal block, □: Connector.
- The setting of the SW2 dip switches differs in the capacity. For the detail, refer to the fig: *1.
- Please set the switch SW5 according to the power supply voltage.
Set SW5 to 240V side when the power supply is 230 and 240 volts.
When the power supply is 220 volts, set SW5 to 220V side.

Led on indoor board for service

Mark	Meaning	Function
LED1	Main power supply	Main power supply (indoor unit: 220-240V) power on → lamp is lit
LED2	Power supply for MA Remote controller	Power supply for MA Remote controller on → lamp is lit

PKFY-P63VFM-E

Drw. : IU-RG79-V059

<SYMBOL EXPLANATION>

Symbol	Name	Symbol	Name	Symbol	Name
I.B	Indoor controller board	C1	Capacitor (fan motor)	TH23	Thermistor Pipe temp.detection/Gas (0°C/15kΩ,25°C/5.4kΩ)
CN32	Connector	Remote switch	LEV	Linear expansion valve	
CN41	HA terminal-A	MF	Fan motor (with inner thermo)	A.B	Circuit board
CN51	Centrally control	MV	Vane motor	SW1	Switch Mode selection
CN52	Remote indication	P.B	Indoor power board	SW5	Voltage selection
F.C	Fan phase control	TB2	Terminal block	SW11	Address setting 1st digit
FUSE	Fuse (6.3A/ 250V)	TB5	Terminal block	SW12	Address setting 2nd digit
SW2	Switch	TB15	Terminal block	SW14	Connection No.
SW3	Capacity code	TH21	Thermistor	SWC	Option selector
SW4	Mode selection	TH22	Thermistor	CNP	Connector D.Heater
X4	Aux.Relay (Fan motor)			X1	Aux. Relay (D.Heater)
ZNR	Varistor			H2	Dew prevention heater

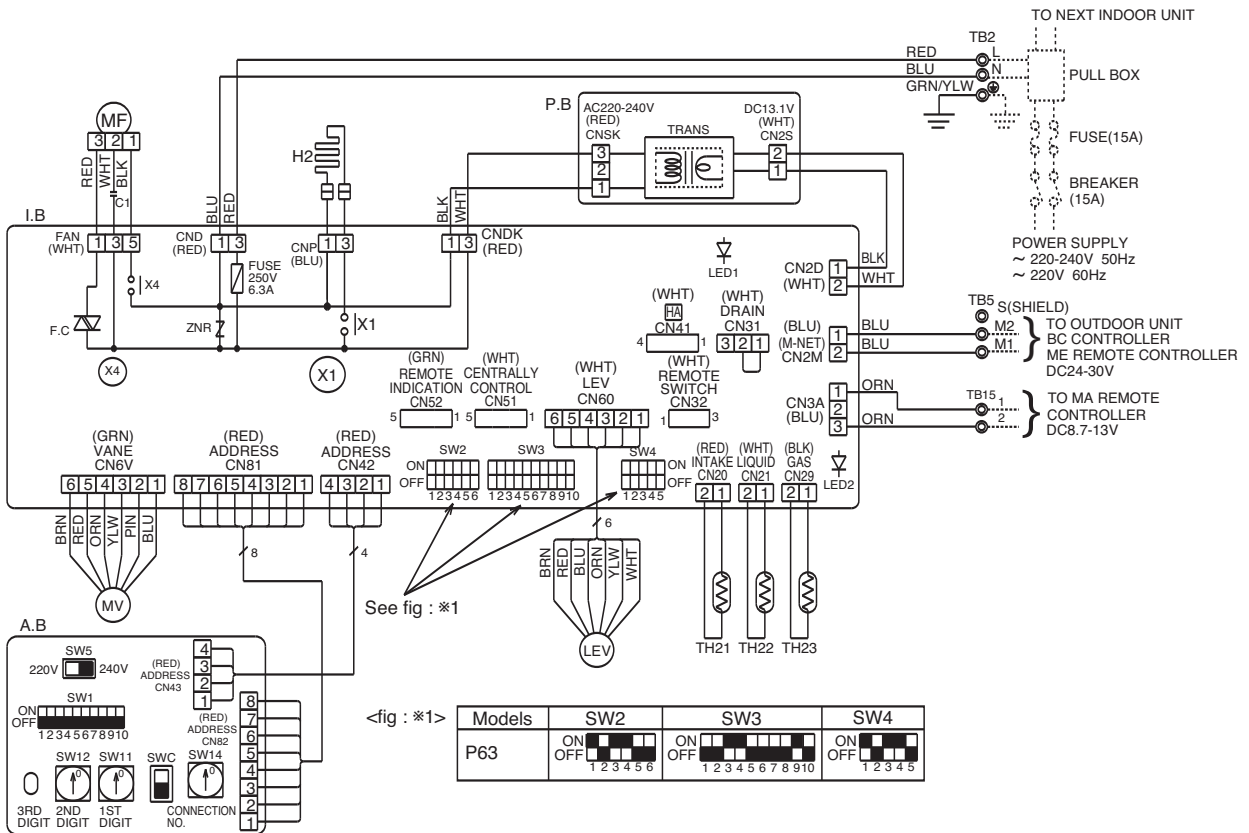

Note

- 1.At servicing for outdoor unit, always follow the wiring diagram of outdoor unit.
- 2.In case of using MA-Remote controller, please connect to TB15.
(Remote controller wire is non-polar.)
- 3.In case of using M-NET, please connect to TB5.
(Transmission line is non-polar.)
- 4.Symbol[S] of TB5 is the shield wire connection.
- 5.Symbols used in wiring diagram above are, ⊙:terminal block, □□:connector.
- 6.The setting of the SW2 dip switches differs in the capacity for the detail, refer to the fig : *1.
- 7.Please set the switch SW5 according to the power supply voltage.
Set SW5 to 240V side when the power supply is 230 and 240 volts.
When the power supply is 220 volts, set SW5 to 220V side.

LED on indoor board for service

Mark	Meaning	Function
LED1	Main power supply	Main power supply (Indoor unit : 220-240V) power on lamp is lit
LED2	Power supply for MA-Remote controller	Power supply for MA-Remote controller on lamp is lit

4. SOUND LEVELS

4-1. Sound levels

PKFY-P-VBM,VGM-E,VFM-E

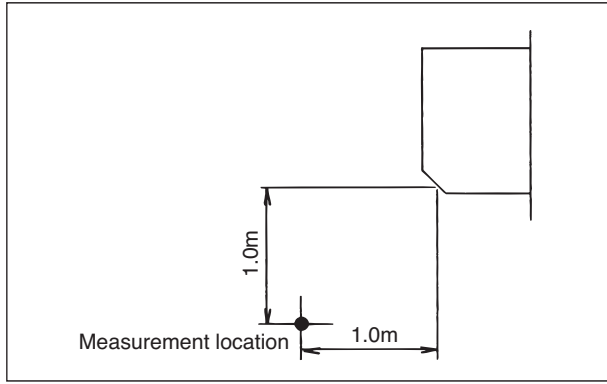

Sound level at anechoic room : Low-(Middle2-Middle1)-High

	Sound level dB (A)
PKFY-P20VBM-E	29-31-34-36
PKFY-P25VBM-E	
PKFY-P32VGM-E	33-36-38-41
PKFY-P40VGM-E	
PKFY-P50VGM-E	34-37-40-43
PKFY-P63VFM-E	39-45

* Measured in anechoic room.

4-2. NC curves

PKFY-P20, 25VBM-E

External static pressure : 0Pa

Power source : 220,230,240V, 50Hz / 220V, 60Hz

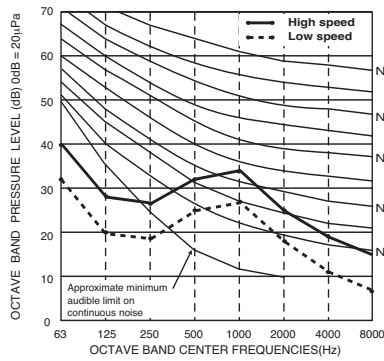

PKFY-P32VGM-E

External static pressure : 0Pa

Power source : 220,230,240V, 50Hz / 220V, 60Hz

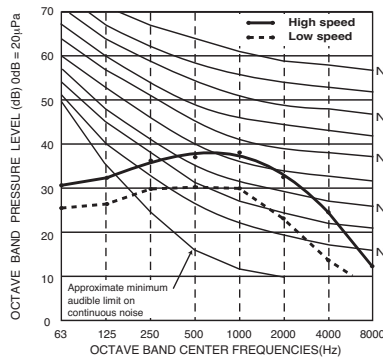

PKFY-P40VGM-E

External static pressure : 0Pa

Power source : 220,230,240V, 50Hz / 220V, 60Hz

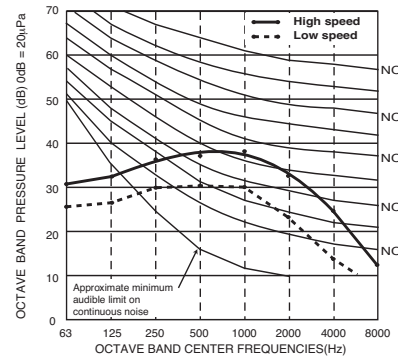

PKFY-P50VGM-E

External static pressure : 0Pa

Power source : 220,230,240V, 50Hz / 220V, 60Hz

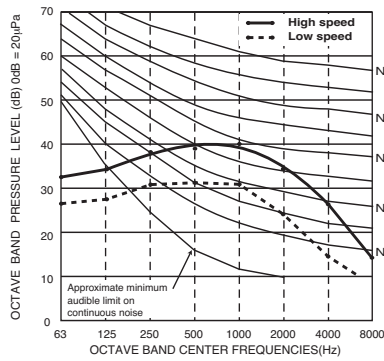

PKFY-P63VFM-E

External static pressure : 0Pa

Power source : 220,230,240V, 50Hz / 220V, 60Hz

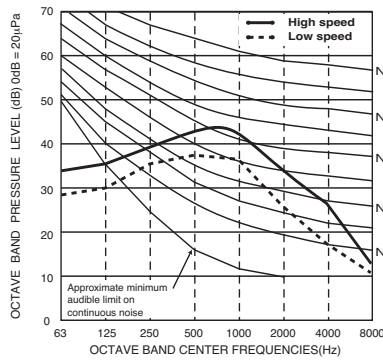

5-1. Temperature distributions

PKFY-P-VBM-E

<Cooling mode>
Horizontal air flow

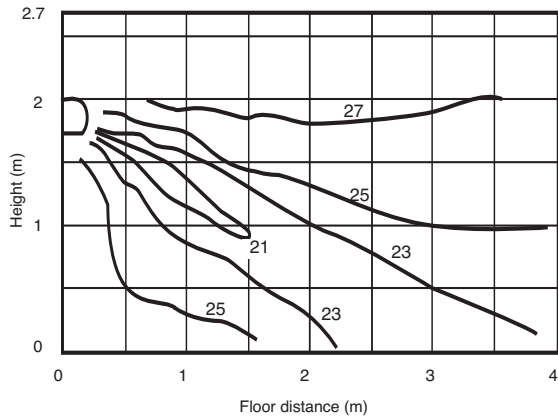

<Heating mode>
Downward air flow

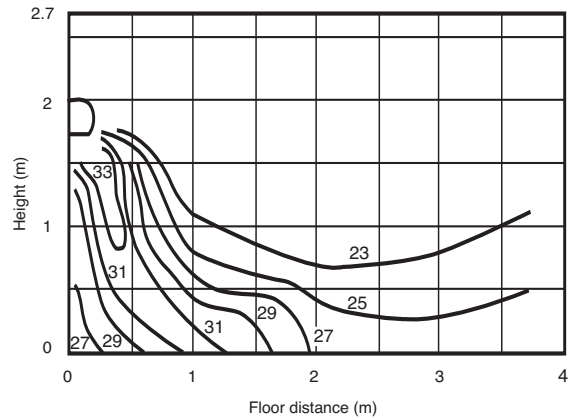

PKFY-P-VGM-E

<Cooling mode>
Flow angle : 10°

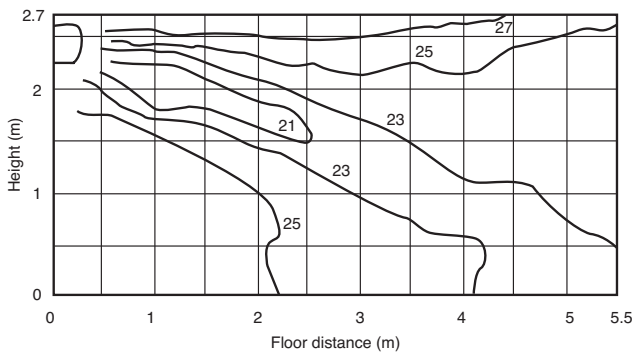

<Heating mode>
Flow angle : 70°



Note : These figures show typical temperature distributions in the conditions above. In the actual installation, they may differ from these figures under the influence of air temperature conditions, ceiling height, cooling/heating load, obstacles, etc.

5-1. Temperature distributions

PKFY-P-VBM-E

<Fan mode>

Horizontal air flow



<Fan mode>

Downward air flow

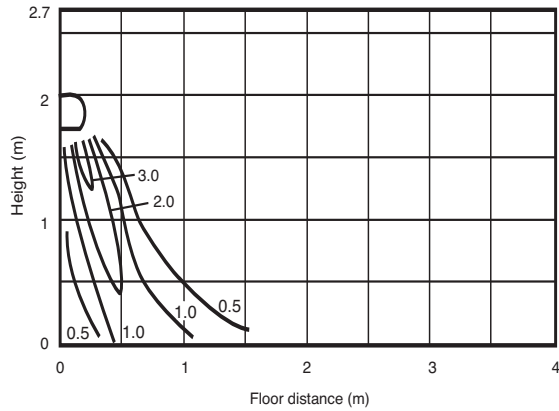

PKFY-P-VGM-E

<Fan mode>

Flow angle : 10°

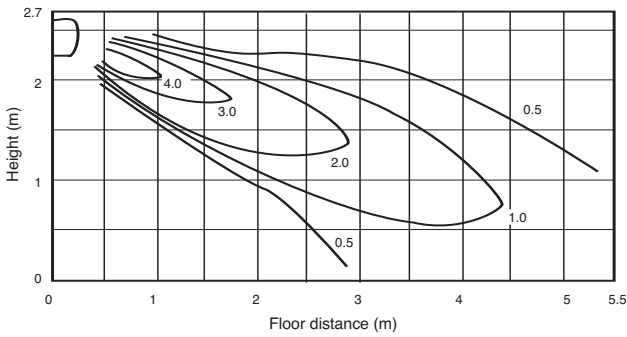

<Fan mode>

Flow angle : 70°

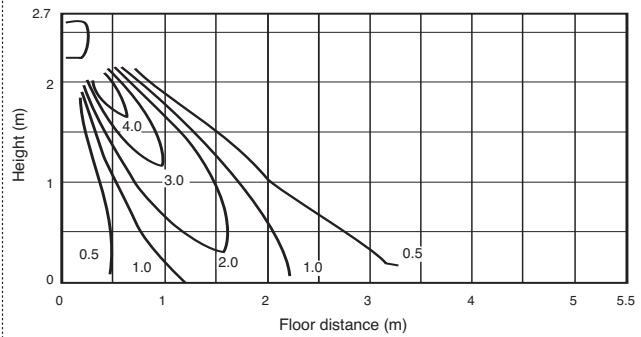

Note : These figures show typical airflow distributions in the conditions above. In the actual installation, they may differ from these figures under the influence of air temperature conditions, ceiling height, cooling/heating load, obstacles, etc.

6. Optional parts for PKFY-P-VBM-E

R410A Data G4

■ Optional parts line up for the indoor unit

	External LEV Box
PKFY-P-VBM-E	PAC-SG95LE-E

A

B

C

D

E

F

G

H

V_a

V_b

BC

CT

- A
- B
- C
- D
- E
- F
- G**
- H
- V_A
- V_B
- EC
- CT