

TECHNICAL & SERVICE MANUAL

Series PKFY **Wall Mounted** **R410A** / **R407C** / **R22**

<Indoor unit>
[Model names]

PKFY-P32VGM-E

PKFY-P40VGM-E

PKFY-P50VGM-E

[Service Ref.]

PKFY-P32VGM-E
PKFY-P40VGM-E
PKFY-P50VGM-E

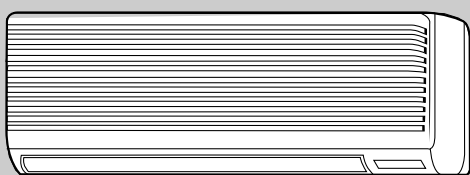

Indoor unit

CONTENTS

1. SAFETY PRECAUTION	2
2. PART NAMES AND FUNCTIONS	6
3. SPECIFICATIONS	8
4. OUTLINES AND DIMENSIONS	10
5. WIRING DIAGRAM	11
6. REFRIGERANT SYSTEM DIAGRAM	12
7. TROUBLE SHOOTING	13
8. DISASSEMBLY PROCEDURE	20
9. PARTS LIST	23

STRUCTURAL PARTS

PKFY-P32VGM-E

PKFY-P40VGM-E

PKFY-P50VGM-E

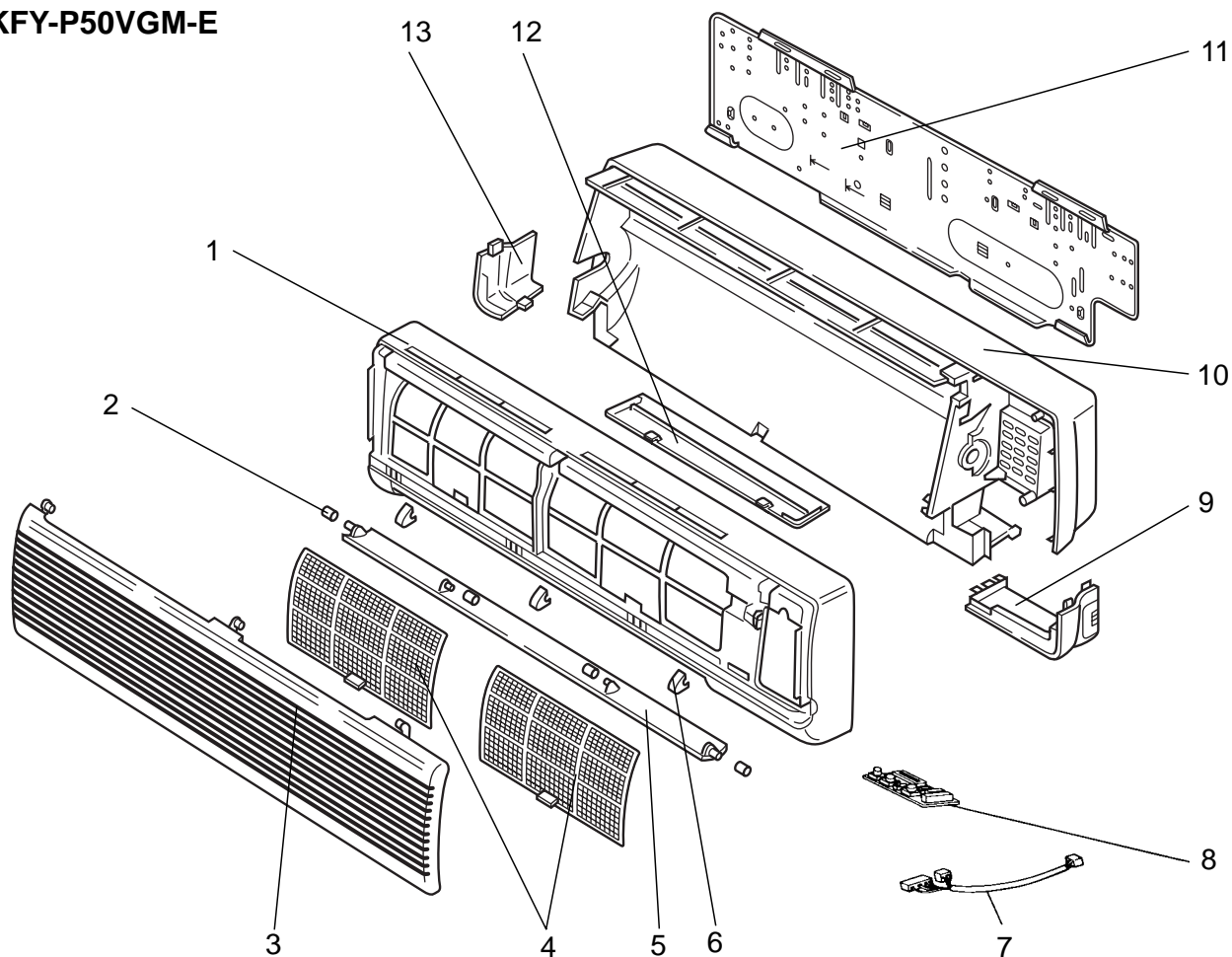

No.	Parts No.	Parts Name	Specifications	PKFY- P32,P40,P50VGM-E	Remarks (Drawing No.)	Wiring Diagram Symbol	Recom- mended Q'ty	Price	
								Unit	Amount
1	R01 89Y 651	FRONT PANEL		1					
2	R01 07Y 092	VANE SLEEVE		1					
3	R01 07Y 691	FRONT GRILLE		1					
4	R01 A16 500	AIR FILTER		2					
5	R01 07Y 002	AUTO VANE		1					
6	R01 07Y 096	SCREW CAP		3					
7	R01 85Y 304	ADDRESS CABLE		1					
8	T7W B01 294	ADDRESS BOARD		1		A.B			
9	R01 07Y 658	CORNER COVER		1					
10	R01 07Y 635	BOX ASSEMBLY		1					
11	R01 07Y 808	BACK PLATE		1					
12	R01 07Y 623	UNDER COVER		1					
13	R01 09Y 658	CORNER COVER		1					

ELECTRICAL PARTS
PKFY-P32VGM-E
PKFY-P40VGM-E
PKFY-P50VGM-E

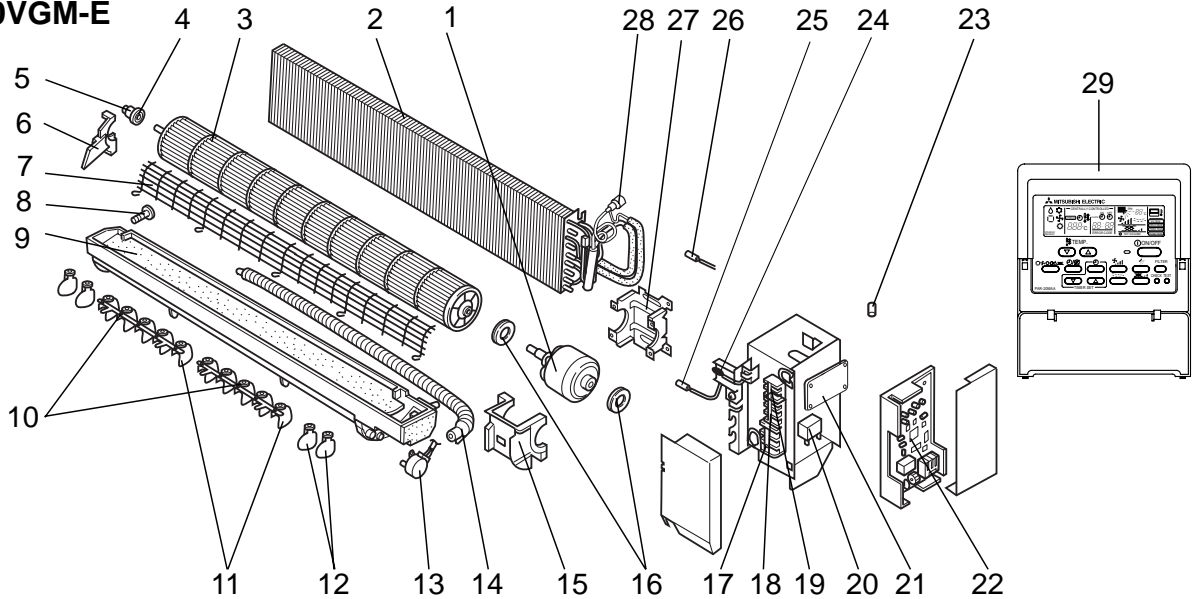

No.	Parts No.	Parts Name	Specifications	PKFY-			Remarks (Drawing No.)	Wiring Diagram Symbol	Recom- mended Q'ty	Price	
				P32VGM -E	P40VGM -E	P50VGM -E				Unit	Amount
1	T7W A01 762	FAN MOTOR		1	1	1					
2	R01 H55 480	HEAT EXCHANGER		1							
	R01 H56 480	HEAT EXCHANGER			1						
	R01 H57 480	HEAT EXCHANGER				1					
3	R01 07Y 114	LINE FLOW FAN		1	1	1					
4	R01 005 103	SLEEVE BEARING		1	1	1					
5	R01 07Y 102	BEARING MOUNT		1	1	1					
6	R01 07Y 106	BEARING SUPPORT		1	1	1					
7	T7W A00 675	FAN GUARD		1	1	1					
8	R01 07Y 524	DRAIN PLUG		1	1	1					
9	R01 07Y 530	NOZZLE ASSY		1	1	1					
10	R01 07Y 059	ARM		2	2	2					
11	R01 07Y 038	GUIDE VANE		10	10	10					
12	R01 09Y 038	GUIDE VANE		4	4	4					
13	R01 E04 223	VANE MOTOR		1	1	1		MV			
14	R01 07Y 527	DRAIN HOSE		1	1	1					
15	R01 07Y 135	MOTOR COVER		1	1	1					
16	R01 07Y 105	RUBBER MOUNT		2	2	2					
17	T7W 512 716	TERMINAL BLOCK	2P(1,2)	1	1	1		TB15			
18	T7W E00 716	TERMINAL BLOCK	3P(M1,M2,S)	1	1	1		TB5			
19	T7W A14 716	TERMINAL BLOCK	3P(L,N,⊕)	1	1	1		TB2			
20	R01 588 255	RUN CAPACITOR	2.0μF 440V	1	1	1		C1			
21	R01 E02 313	POWER BOARD		1	1	1		P.B			
22	T7W E34 310	CONTROLLER BOARD		1	1	1		I.B			
23	T7W 520 239	FUSE	250V 6.3A	1	1	1		FUSE			
24	R01 E26 202	ROOM THERMISTOR		1	1	1		TH21			
25	R01 E28 202	LIQUID PIPE THERMISTOR		1	1	1		TH22			
26	R01 E34 202	GAS PIPE THERMISTOR		1	1	1		TH23			
27	R01 07Y 130	MOTOR SUPPORT		1	1	1					
28	R01 E63 401	LINEAR EXPANSION VALVE		1	1	1		LEV			
29	—	REMOTE CONTROLLER	PAR-20MAA	1	1	1					

MITSUBISHI ELECTRIC CORPORATION
 HEAD OFFICE : MITSUBISHI DENKI BLDG., 2-2-3, MARUNOUCHI, CHIYODA-KU TOKYO 100-8310, JAPAN