

TECHNICAL & SERVICE MANUAL

Series PKFY **Wall Mounted** **R410A** / **R407C** / **R22**

Indoor unit
[Model names]

PKFY-P20VAM-E

PKFY-P25VAM-E

[Service Ref.]

PKFY-P20VAM-E

PKFY-P25VAM-E

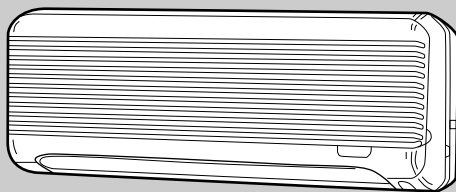

INDOOR UNIT

CONTENTS

1. SAFETY PRECAUTION	2
2. PART NAMES AND FUNCTIONS	6
3. SPECIFICATION	8
4. OUTLINES AND DIMENSIONS	10
5. WIRING DIAGRAM	11
6. REFRIGERANT SYSTEM DIAGRAM	12
7. TROUBLESHOOTING	12
8. DISASSEMBLY PROCEDURE	19
9. PARTS LIST	22

PANEL PARTS
PKFY-P20VAM-E
PKFY-P25VAM-E

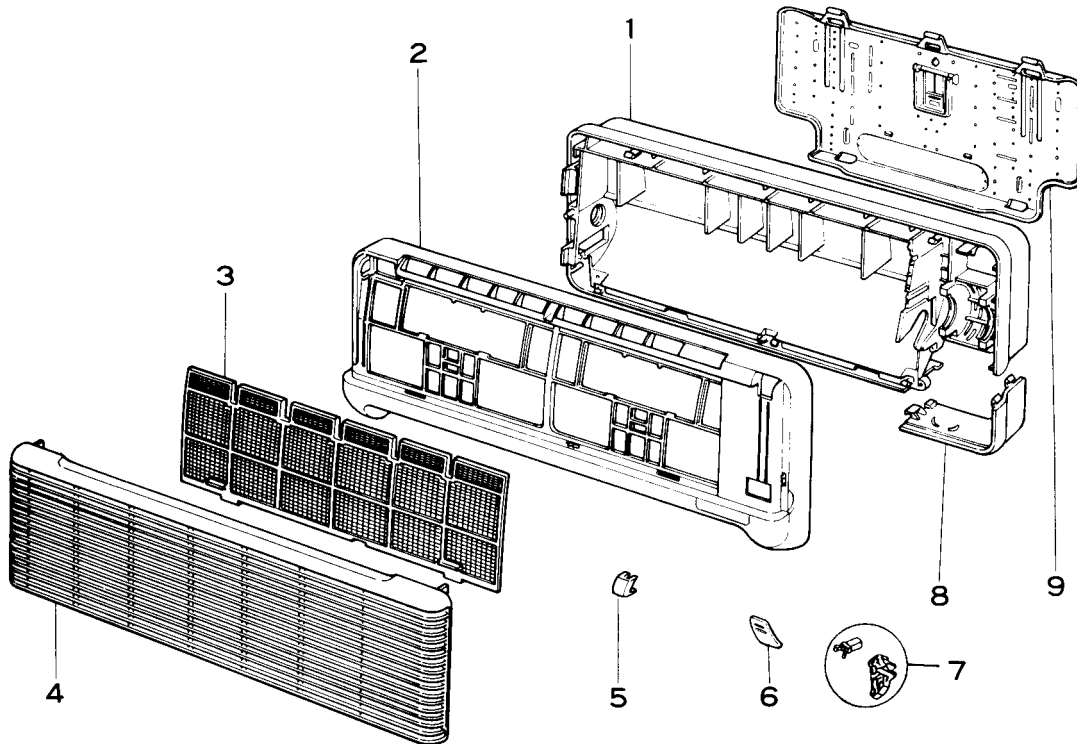

Part number that is circled is not shown in the figure.

No.	Parts No.	Parts Name	Specifications	Q'ty / set	Remarks (Drawing No.)	Wiring Diagram Symbol	Recom- mended Q'ty	Price	
				PKFY-P20VAM-E PKFY-P25VAM-E				Unit	Amount
1	R01 22A 635	BOX		1					
2	R01 22A 651	FRONT PANEL		1					
3	R01 22A 500	AIR FILTER		1					
4	R01 22A 691	INTAKE GRILLE		1					
5	R01 22A 096	SCREW CAP		1	3PCS/SET				
6	—	RECEIVING COVER		1	(DT25C174H03)				
7	R01 22A 054	GRILLE CATCH		1					
8	T7W A00 658	CORNER BOX		1					
9	R01 22A 808	BACK PLATE		1					
⑩	—	BRAND LABEL		1	(BC79R798H02)				

ELECTRICAL PARTS PKFY-P20VAM-E PKFY-P25VAM-E

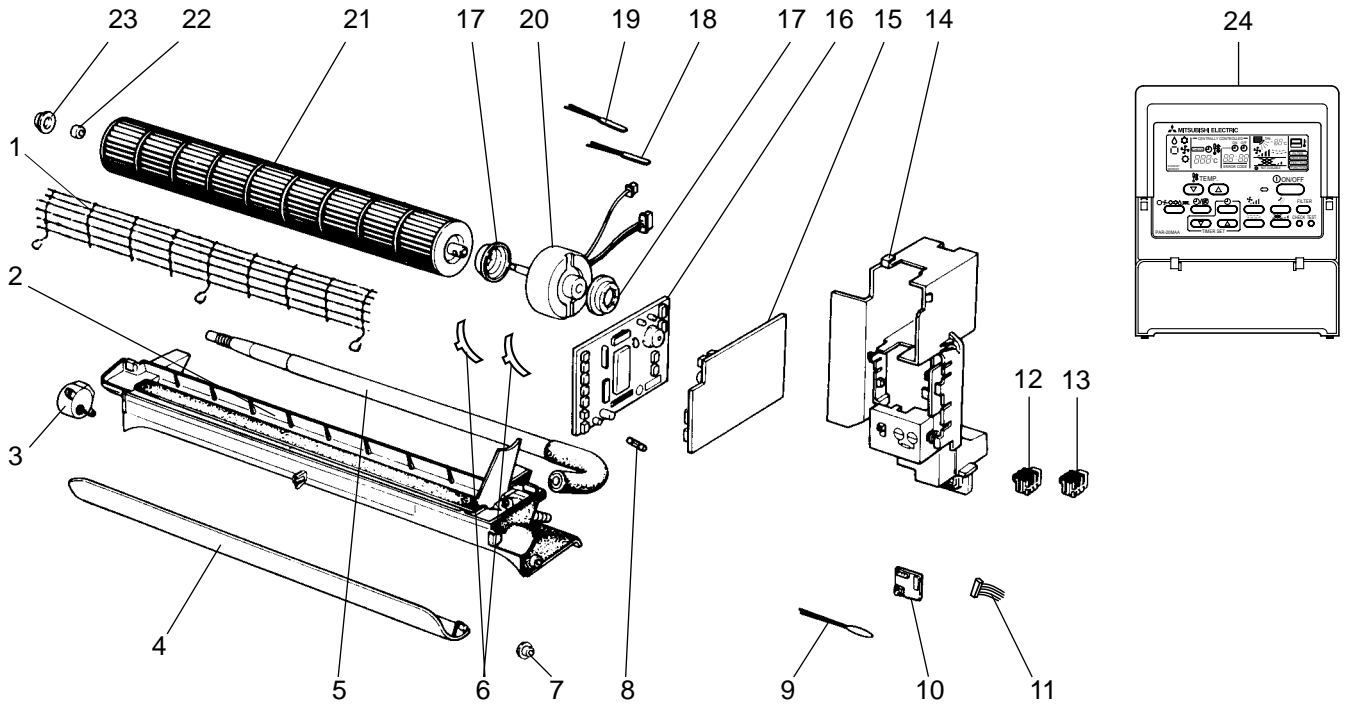

No.	Parts No.	Parts Name	Specifications	Q'ty / set		Remarks (Drawing No.)	Wiring Diagram Symbol	Recom- mended Q'ty	Price	
				PKFY- P20VAM-E	PKFY- P25VAM-E				Unit	Amount
1	T7W B00 675	FAN GUARD		1	1					
2	R01 22A 530	NOZZLE		1	1					
3	R01 22A 223	VANE MOTOR		1	1		MV			
4	R01 22A 002	AUTO VANE		1	1					
5	R01 22A 527	DRAIN HOSE		1	1					
6	R01 22A 126	MOTOR BAND	SET (LEFT, RIGHT)	1	1					
7	R01 07Y 092	VANE SLEEVE		1	1					
8	T7W 520 239	FUSE	250V 6.3A	1	1		FUSE			
9	T7W E12 202	ROOM TEMPERATURE THERMISTOR		1	1		TH21			
10	T7W B01 294	ADDRESS BOARD		1	1		A.B			
11	T7W E00 304	ADDRESS CABLE		1	1					
12	T7W 512 716	TERMINAL BLOCK	2P (M1, M2)	1	1		TB5			
13	T7W E05 716	TERMINAL BLOCK	3P (L, N, ⊕)	1	1		TB2			
14	—	ELECTRICAL BOX		1	1	(BG00J285G24)				
15	T7W E03 313	POWER BOARD		1	1		P.B			
16	R01 H17 310	INDOOR CONTROLLER BOARD		1	1		M.B			
17	R01 22A 105	RUBBER MOUNT		2	2					
18	R01 E38 202	PIPE TEMPERATURE THERMISTOR	GAS	1	1		TH23			
19	T7W E06 202	PIPE TEMPERATURE THERMISTOR	LIQUID	1	1		TH22			
20	T7W E11 762	FAN MOTOR	PS4V17-KA	1	1		MF			
21	R01 22A 114	LINE FLOW FAN		1	1					
22	R01 005 103	SLEEVE BEARING		1	1					
23	R01 22A 102	BEARING MOUNT		1	1					
24	—	REMOTE CONTROLLER	PAR-20MAA	1	1		R.B			

HEAT EXCHANGER PARTS
PKFY-P20VAM-E
PKFY-P25VAM-E

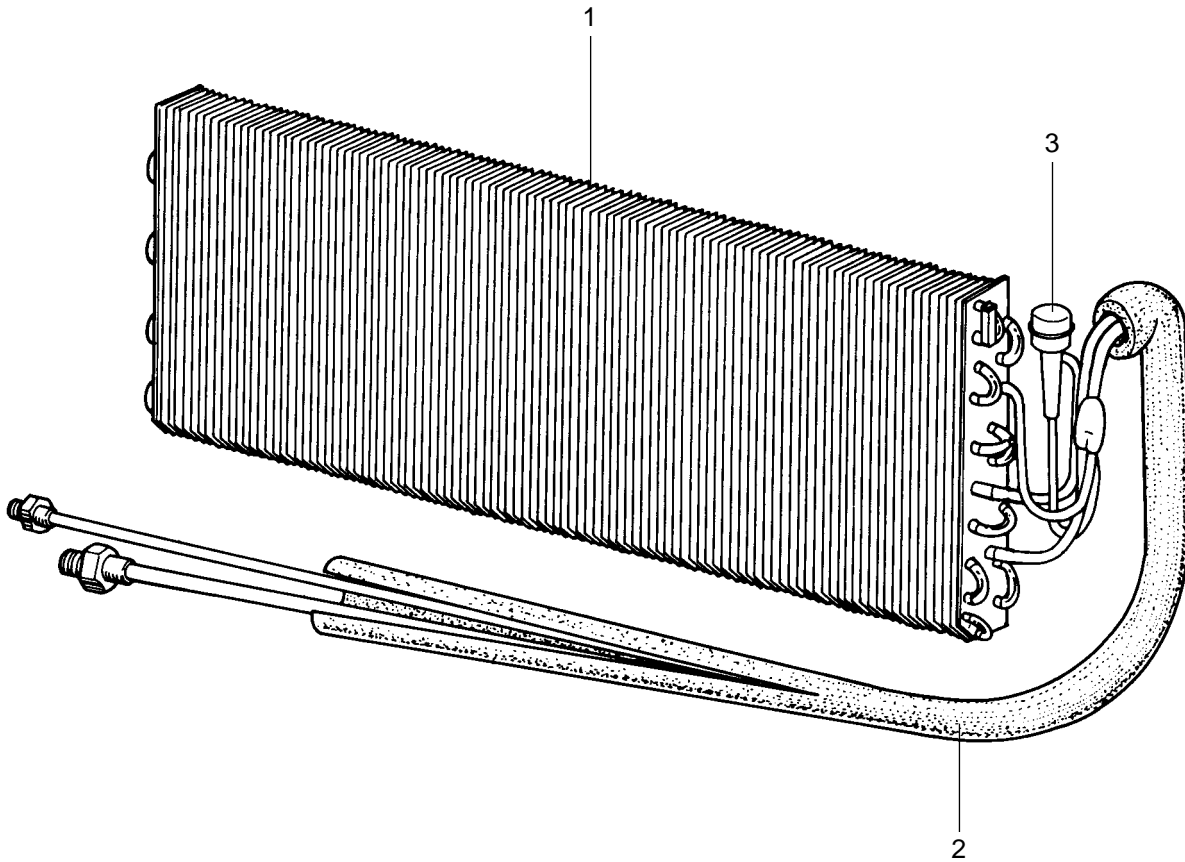

No.	Parts No.	Parts Name	Specifications	Q'ty / set		Remarks (Drawing No.)	Wiring Diagram Symbol	Recom- mended Q'ty	Price	
				PKFY- P20VAM-E	PKFY- P25VAM-E				Unit	Amount
1	R01 H58 480	HEAT EXCHANGER		1						
	R01 H59 480	HEAT EXCHANGER			1					
2	R01 E03 470	CONNECT PIPE		1	1					
3	R01 E63 401	LINEAR EXPANSION VALVE		1	1		LEV			

MITSUBISHI ELECTRIC CORPORATION

HEAD OFFICE : MITSUBISHI DENKI BLDG., 2-2-3, MARUNOUCHI, CHIYODA-KU TOKYO 100-8310, JAPAN