

# TECHNICAL & SERVICE MANUAL

**Series PKFY** **Wall Mounted** **R410A** / **R407C** / **R22**

Indoor unit  
[Model names]

PKFY-P20VAM-E

PKFY-P25VAM-E

[Service Ref.]

**PKFY-P20VAM-E**

**PKFY-P25VAM-E**

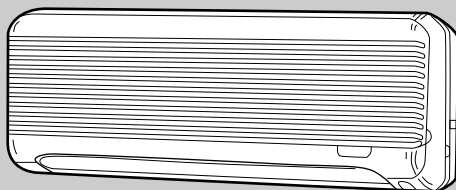

INDOOR UNIT

## CONTENTS

1. SAFETY PRECAUTION .....	2
2. PART NAMES AND FUNCTIONS .....	6
3. SPECIFICATION .....	8
4. OUTLINES AND DIMENSIONS .....	10
5. WIRING DIAGRAM .....	11
6. REFRIGERANT SYSTEM DIAGRAM .....	12
7. TROUBLESHOOTING .....	12
8. DISASSEMBLY PROCEDURE .....	19
9. PARTS LIST .....	22

## CAUTIONS RELATED TO NEW REFRIGERANT

## Cautions for units utilizing refrigerant R407C

**Do not use the existing refrigerant piping.**

The old refrigerant and lubricant in the existing piping contains a large amount of chlorine which may cause the lubricant deterioration of the new unit.

**Use liquid refrigerant to seal the system.**

If gas refrigerant is used to seal the system, the composition of the refrigerant in the cylinder will change and performance may drop.

**Use "low residual oil piping"**

If there is a large amount of residual oil (hydraulic oil, etc.) inside the piping and joints, deterioration of the lubricant will result.

**Do not use a refrigerant other than R407C.**

If another refrigerant (R22, etc.) is used, the chlorine in the refrigerant may cause the lubricant deterioration.

**Store the piping to be used during installation indoors with keep both ends sealed until just before brazing.  
(Store elbows and other joints in a plastic bag.)**

If dust, dirt, or water enters the refrigerant cycle, deterioration of the oil and compressor trouble may result.

**Use a vacuum pump with a reverse flow check valve.**

The vacuum pump oil may flow back into the refrigerant cycle and cause the lubricant deterioration.

**Use ESTR , ETHER or HAB as the lubricant to coat flares and flange connection parts.**

If large amount of mineral oil enter, that can cause deterioration of refrigerant oil etc.

**Ventilate the room if refrigerant leaks during operation. If refrigerant comes into contact with a flame, poisonous gases will be released.****[1] Cautions for service**

- After recovering the all refrigerant in the unit, proceed to working.
- Do not release refrigerant in the air.
- After completing the repair service, recharge the cycle with the specified amount of liquid refrigerant.

**[2] Refrigerant recharging**

## (1) Refrigerant recharging process

## ① Direct charging from the cylinder.

- R407C cylinder are available on the market has a syphon pipe.
- Leave the syphon pipe cylinder standing and recharge it.  
(By liquid refrigerant)

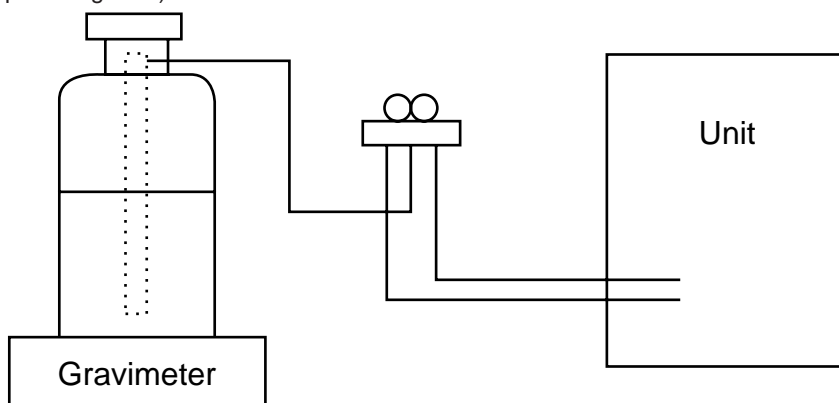

## (2) Recharge in refrigerant leakage case

- After recovering the all refrigerant in the unit, proceed to working.
- Do not release the refrigerant in the air.
- After completing the repair service, recharge the cycle with the specified amount of liquid refrigerant.

### [3] Service tools

Use the below service tools as exclusive tools for R407C refrigerant.

No.	Tool name	Specifications
①	Gauge manifold	·Only for R407C.
		·Use the existing fitting SPECIFICATIONS. (UNF7/16)
		·Use high-tension side pressure of 3.43MPa-G or over.
②	Charge hose	·Only for R407C.
		·Use pressure performance of 5.10MPa-G or over.
③	Electronic scale	
④	Gas leak detector	·Use the detector for R134a or R407C.
⑤	Adapter for reverse flow check.	·Attach on vacuum pump.
⑥	Refrigerant charge base.	
⑦	Refrigerant cylinder.	·For R407C      ·Top of cylinder (Brown)
		·Cylinder with syphon
⑧	Refrigerant recovery equipment.	

## Cautions for units utilizing refrigerant R410A

### Do not use the existing refrigerant piping.

The old refrigerant and lubricant in the existing piping contains a large amount of chlorine which may cause the lubricant deterioration of the new unit.

### Use "low residual oil piping"

If there is a large amount of residual oil (hydraulic oil, etc.) inside the piping and joints, deterioration of the lubricant will result.

### Store the piping to be used during installation indoors and keep both ends of the piping sealed until just before brazing. (Leave elbow joints, etc. in their packaging.)

If dirt, dust or moisture enter into refrigerant cycle, that can cause deterioration of refrigerant oil or malfunction of compressor.

### Use ester oil, ether oil or alkylbenzene oil (small amount) as the refrigerant oil applied to flares and flange connections.

If large amount of mineral oil enter, that can cause deterioration of refrigerant oil etc.

### Charge refrigerant from liquid phase of gas cylinder.

If the refrigerant is charged from gas phase, composition change may occur in refrigerant and the efficiency will be lowered.

### Do not use refrigerant other than R410A.

If other refrigerant (R22 etc.) is used, chlorine in refrigerant can cause deterioration of refrigerant oil etc.

### Use a vacuum pump with a reverse flow check valve.

Vacuum pump oil may flow back into refrigerant cycle and that can cause deterioration of refrigerant oil etc.

### Use the following tools specifically designed for use with R410A refrigerant.

The following tools are necessary to use R410A refrigerant.

Tools for R410A	
Gauge manifold	Flare tool
Charge hose	Size adjustment gauge
Gas leak detector	Vacuum pump adaptor
Torque wrench	Electronic refrigerant charging scale

### Keep the tools with care.

If dirt, dust or moisture enter into refrigerant cycle, that can cause deterioration of refrigerant oil or malfunction of compressor.

### Do not use a charging cylinder.

If a charging cylinder is used, the composition of refrigerant will change and the efficiency will be lowered.

### Ventilate the room if refrigerant leaks during operation. If refrigerant comes into contact with a flame, poisonous gases will be released.

### [1] Cautions for service

- (1) Perform service after collecting the refrigerant left in unit completely.
- (2) Do not release refrigerant in the air.
- (3) After completing service, charge the cycle with specified amount of refrigerant.
- (4) When performing service, install a filter drier simultaneously.  
Be sure to use a filter drier for new refrigerant.

### [2] Additional refrigerant charge

#### When charging directly from cylinder

- Check that cylinder for R410A on the market is syphon type.
- Charging should be performed with the cylinder of syphon stood vertically. (Refrigerant is charged from liquid phase.)

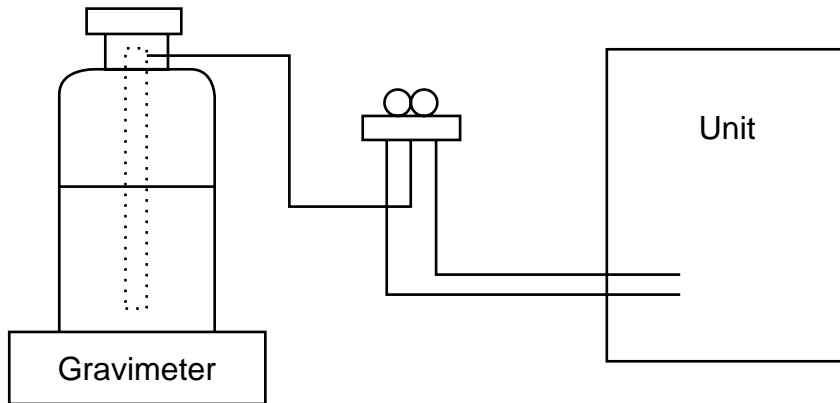

### [3] Service tools

Use the below service tools as exclusive tools for R410A refrigerant.

No.		Specifications
①	Gauge manifold	·Only for R410A
		·Use the existing fitting specifications. (UNF1/2)
		·Use high-tension side pressure of 5.3MPa-G or over.
②	Charge hose	·Only for R410A
		·Use pressure performance of 5.09MPa-G or over.
③	Electronic scale	—
④	Gas leak detector	·Use the detector for R134a, R407C or R410A.
⑤	Adaptor for reverse flow check	·Attach on vacuum pump.
⑥	Refrigerant charge base	—
⑦	Refrigerant cylinder	·Only for R410A
		Top of cylinder (Pink) Cylinder with syphon
⑧	Refrigerant recovery equipment	—

● Indoor Unit

PKFY-P20VAM-E

PKFY-P25VAM-E

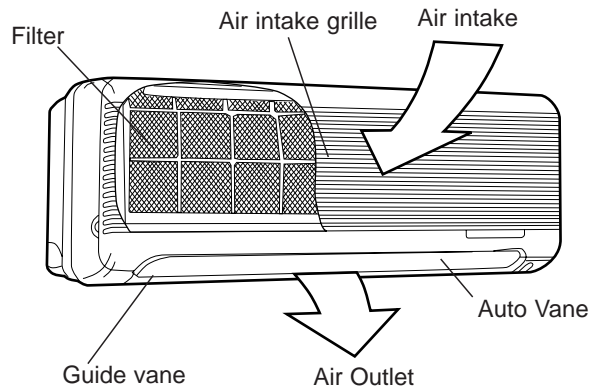

● MA remote controller [PAR-20MAA]

- Once the operation of the unit is set, subsequent operations can only be performed by pressing the ON/OFF button repeatedly.

● Operation buttons

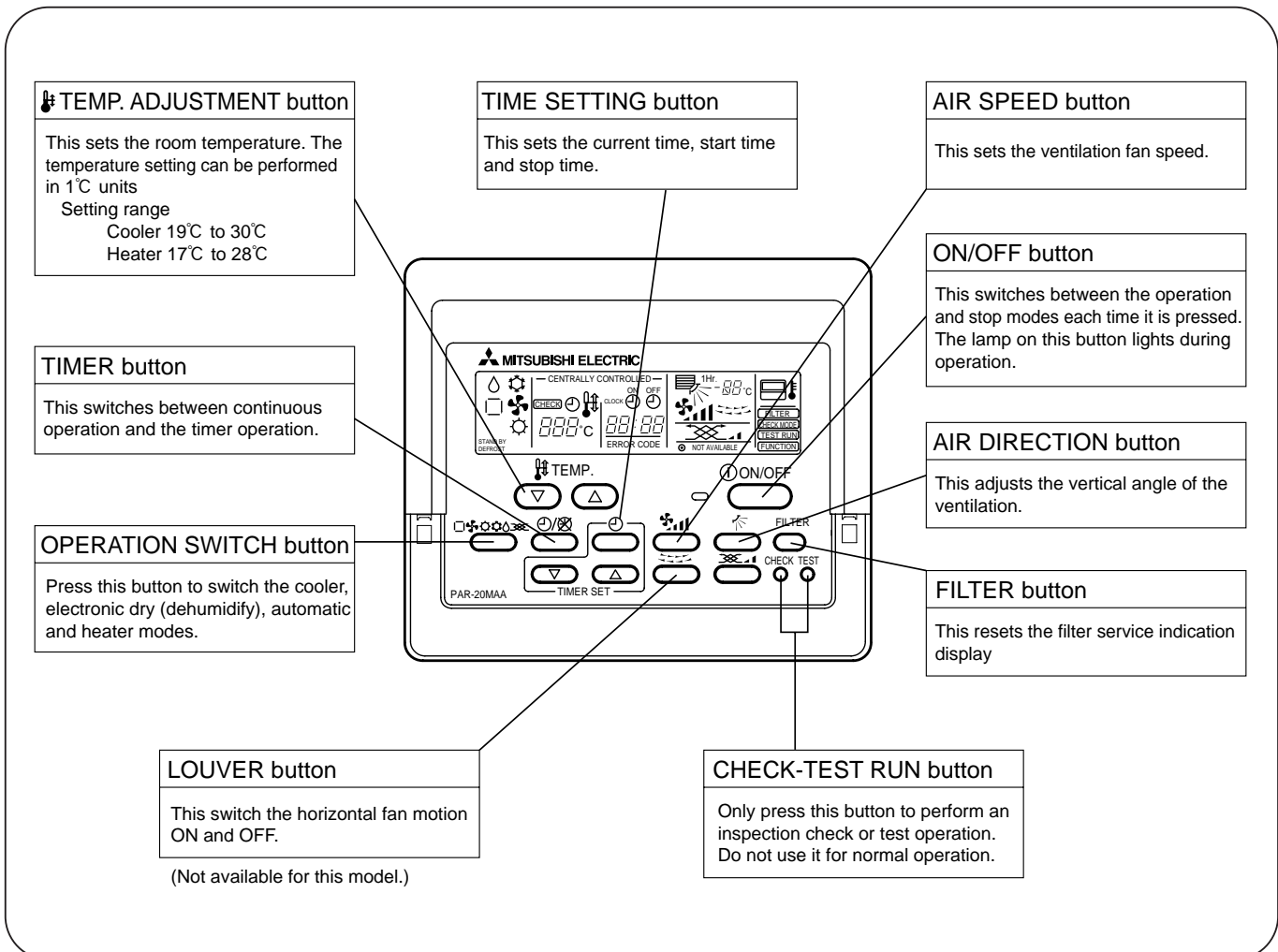

## ● Display

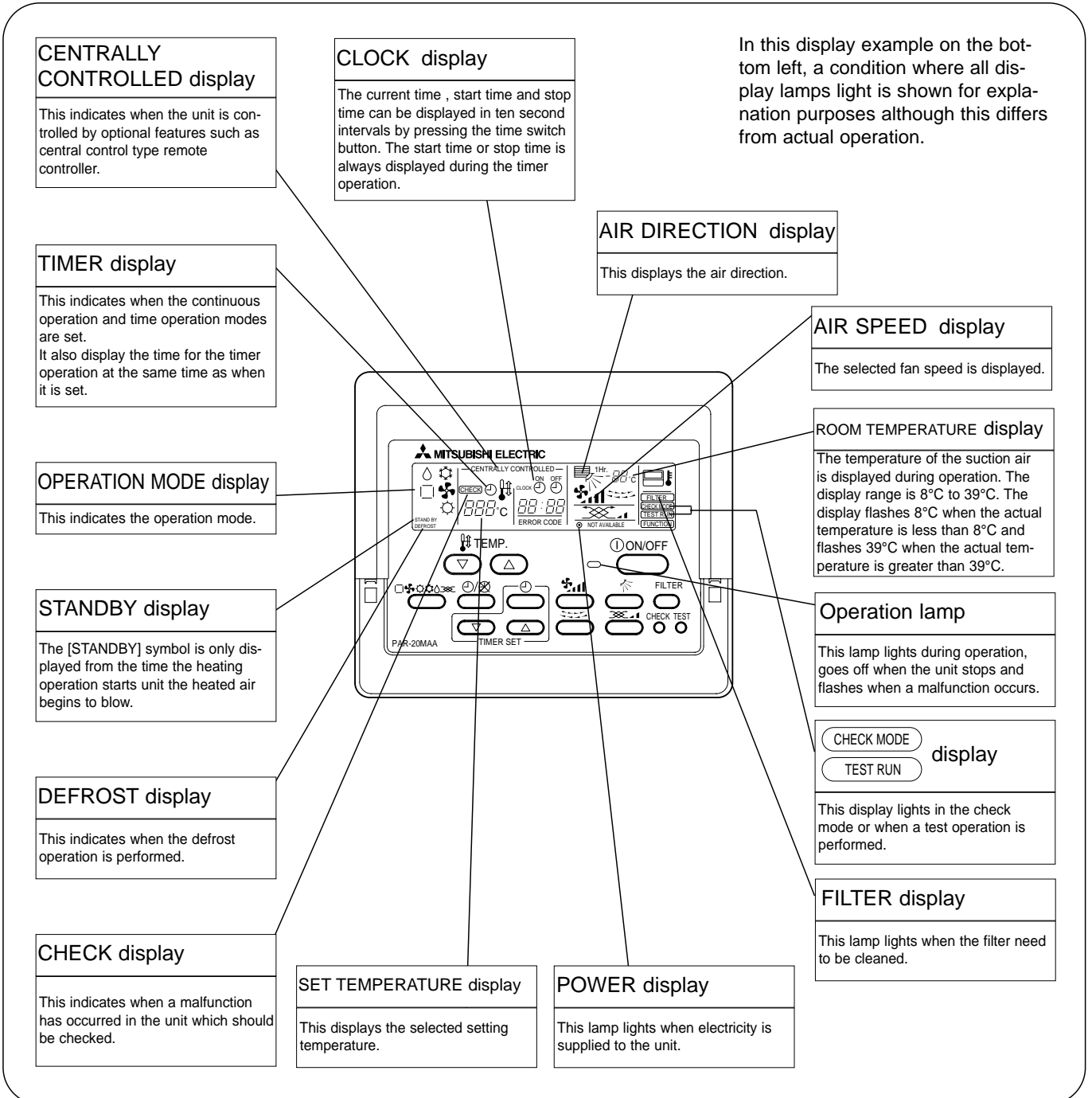

### Caution

- Only the Power display lights when the unit is stopped but power is supplied to the unit.
- When the central control remote control unit, which is sold separately, is used the ON-OFF button, operation switch button and TEMP. adjustment button do not operate.
- "NOT AVAILABLE" is displayed when the Air speed button are pressed. This indicates that this room unit is not equipped with the fan direction adjustment function and the louver function.
- When power is turned ON for the first time, it is normal that "H0" is displayed on the room temperature indication (For max. 2minutes). Please wait until this "H0" indication disappear then start the operation.

## 3-1. Specification

Item		Unit	PKFY-P20VAM-E	PKFY-P25VAM-E
Power		$\phi, V, Hz$	Single phase, 220-230-240V, 50Hz Single phase, 220V, 60Hz	
Cooling capacity		kW	2.2	2.8
Heating capacity		kW	2.5	3.2
Electric characteristic	Power Supply	Cooling	kW	0.04
		Heating	kW	0.04
	Starting Current	Cooling	A	0.20
		Heating	A	0.20
Exterior <munsell symbol>		—	Plastic munsell : <2.60Y 8.66/0.69>	
Out dimensions	Height	mm	295	
	Width	mm	815	
	Depth	mm	158	
Heat exchanger		—	Cross fin	
Fan	Fan X No.	—	Lineflow fan X 1	
	Air flow ※ 2	m <sup>3</sup> /min	5.9-5.6-5.2-4.9	
	External static pressure	Pa	0	
	Fan motor output	kW	0.017	
Insulator		—	Polyethylene sheet	
Air filter		—	PP honey comb	
Pipe dimensions	Gas side	$\phi mm(in.)$	12.7 (1/2")	
	Liquid side	$\phi mm(in.)$	6.35 (1/4")	
Unit drain pipe size		$\phi mm$	PVC pipe VP-16 connectable (I.D. 16)	
Noise level ※ 2		dB	36-35-33-32	
Product weight		kg	8.5	

**Note 1.** Rating conditions (JIS B 8615-1)

Cooling : Indoor D.B. 27°C W.B. 19°C

Outdoor D.B. 35°C

Heating : Indoor D.B. 20°C

Outdoor D.B. 7°C W.B. 6°C

※ 2. Air flow and the noise level are indicated as High – Middium1 – Middium2 – Low.



### 3-2. Electrical parts specifications

Parts name \ Model	Symbol	PKFY-P20VAM-E	PKFY-P25VAM-E
Room temperature thermistor	TH21	Resistance 0°C/15kΩ, 10°C/9.6kΩ, 20°C/6.3kΩ, 25°C/5.4kΩ, 30°C/4.3kΩ, 40°C/3.0kΩ	
Liquid pipe thermistor	TH22	Resistance 0°C/15kΩ, 10°C/9.6kΩ, 20°C/6.3kΩ, 25°C/5.4kΩ, 30°C/4.3kΩ, 40°C/3.0kΩ	
Gas pipe thermistor	TH23	Resistance 0°C/15kΩ, 10°C/9.6kΩ, 20°C/6.3kΩ, 25°C/5.4kΩ, 30°C/4.3kΩ, 40°C/3.0kΩ	
Fuse (Indoor controller board)	FUSE	250V 6.3A	
Fan motor (with thermal fuse)	MF	4-Pole Output 17W / RC4V17	
Fan motor capacitor	C1	1.5μF X 440V	
Vane motor (with limit switch)	MV	MSFBC20A76 DC12V	
Linear expansion valve	LEV	DC12V Stepping motor drive Port φ3.2 (0~2000pulse)	
Power supply terminal block	TB2	(L, N, ⊕) 250V 20A	
Transmission terminal block	TB5	(M1, M2) 250V 10A	

PKFY-P20VAM-E  
PKFY-P25VAM-E

Unit : mm

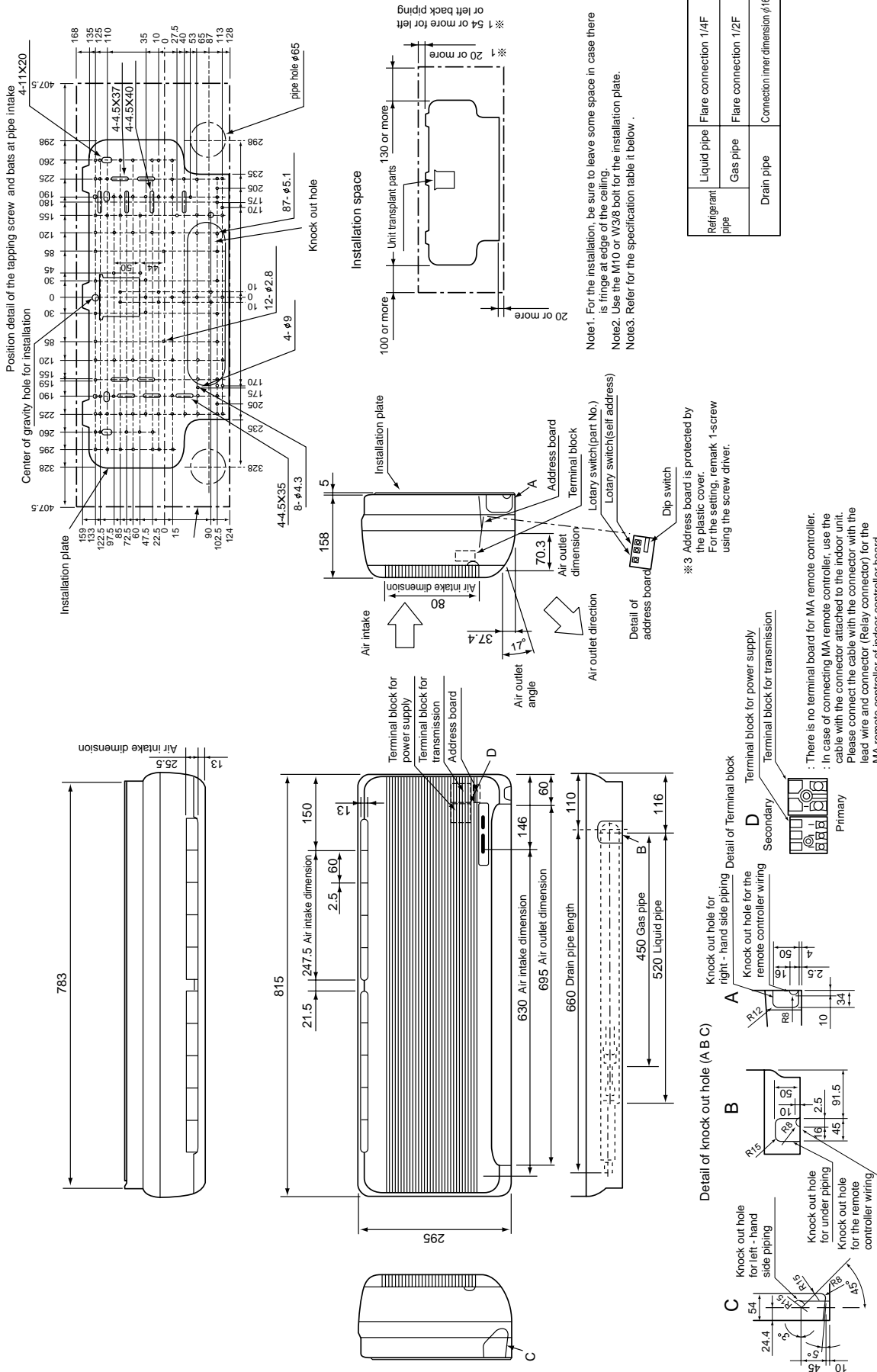

PKFY-P20VAM-E  
PKFY-P25VAM-E

Legend

Symbol	Name	Symbol	Name	Symbol	Name
M.B	Indoor controller board	TH23	Thermistor	TB2	Terminal block
CN32	Connector	TH22	Pipe temperature,detection/Gas (0°C/15kΩ,25°C/5.4kΩ)	TB5	Terminal block
CN41	Remote switch	P.B	Indoor power board	A.B	Circuit board
CN51	HA terminal-A	ZNR	Varistor	SW1<A.B>	Switch
CN52	Centrally control	FUSE	Fuse (6.3A)	SW5<A.B>	Mode selection
SW2	Switch	F.C	Fan phase control	SW11<A.B>	Voltage selection
SW3	Capacity code	MF	Fan motor	SW12<A.B>	Address setting 1st digit
TH21	Thermistor	C1	Capacitor(fan motor)	SW14<A.B>	Address setting 2nd digit
TH22	Room temperature,detection (0°C/15kΩ,25°C/5.4kΩ)	MV	Vane motor		Connection No.
	Pipe temperature,detection/liquid (0°C/15kΩ,25°C/5.4kΩ)	LEV	Linear expansion valve		

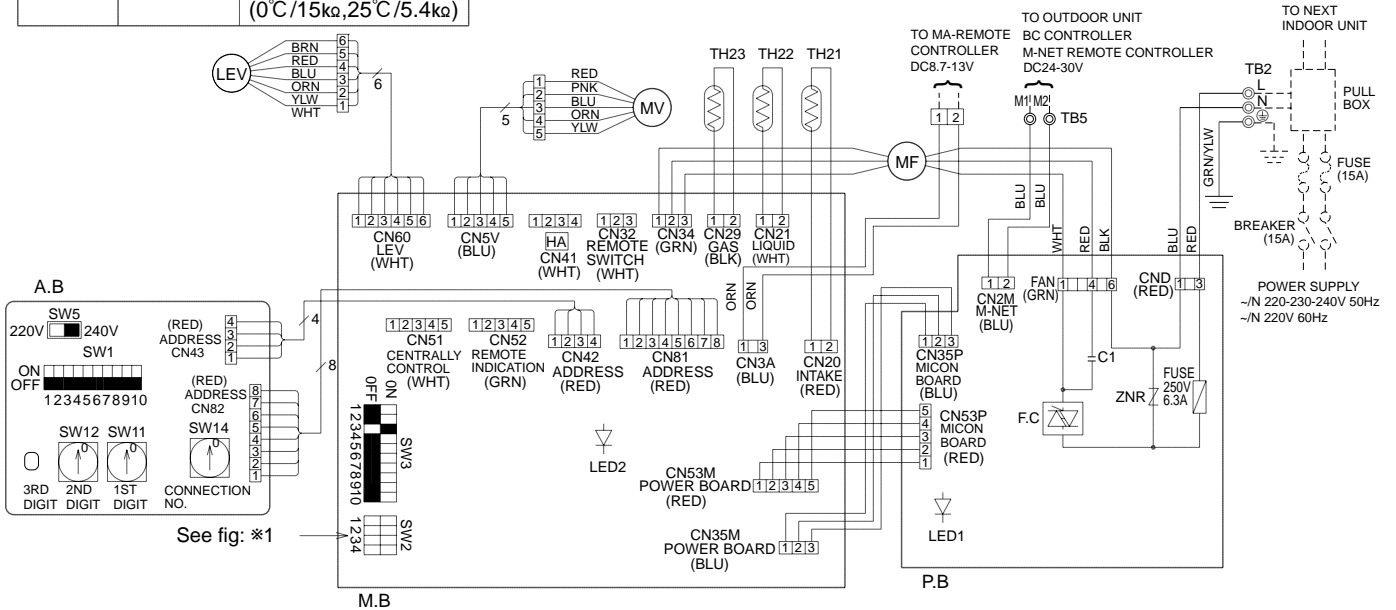

Note

- At servicing for outdoor unit, always follow the wiring diagram of outdoor unit.
- In case of connecting MA-remote controller, please connect MA remote controller cable in an accessory to the connector [1][2]. (Remote controller wire is non-polar.)
- In case of using M-NET, please connect to TB5. (Transmission line is non-polar.)
- Symbols used in wiring diagram above are, ⊙: terminal block, □: connector.
- The setting of the SW2 dip switches differs in the capacity. For the detail, refer to the fig: \*1.
- Please set the switch SW5 according to the power supply voltage.  
Set SW5 to 240V side when the power supply is 230 and 240 volts.  
When the power supply is 220 volts, set SW5 to 220V side.

LED on indoor board for service

Mark	Meaning	Function
LED1	Main power supply	Main power supply(Indoor unit:220-240V) power on → lamp is lit
LED2	Power supply for MA-Remote controller	Power supply for MA-Remote controller on → lamp is lit

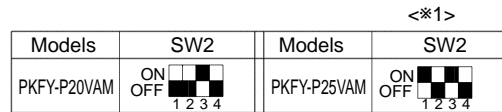

# 6

# REFRIGERANT SYSTEM DIAGRAM

PKFY-P20VAM-E  
PKFY-P25VAM-E

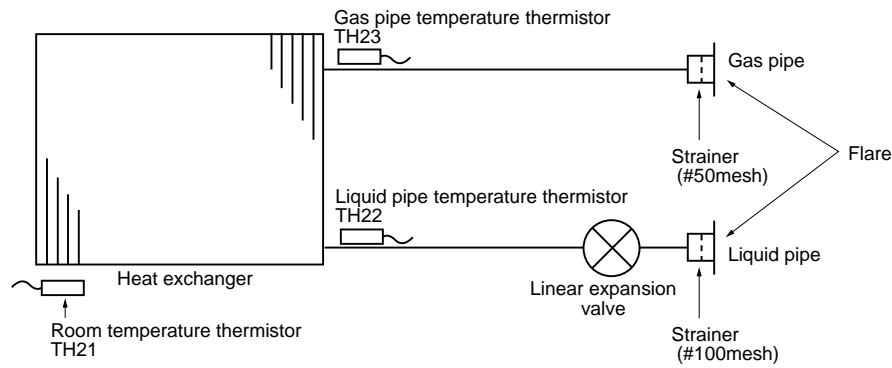

Item	Models	
	PKFY-P20VAM-E	PKFY-P25VAM-E
Gas pipe	φ12.7 (1/2")	
Liquid pipe	φ6.35 (1/4")	

# 7

# TROUBLESHOOTING

## 7-1. How to check

PKFY-P20VAM-E PKFY-P25VAM-E

Parts name	Check points														
Room temperature thermistor (TH21) Liquid pipe temperature thermistor (TH22) Gas pipe temperature thermistor (TH23)	Disconnect the connector then measure the resistance using a tester. (Surrounding temperature 10°C ~30°C) <table border="1"> <thead> <tr> <th>Normal</th> <th>Abnormal</th> </tr> </thead> <tbody> <tr> <td>4.3kΩ~9.6kΩ</td> <td>Open or short</td> </tr> </tbody> </table> Refer to the next page for the details.	Normal	Abnormal	4.3kΩ~9.6kΩ	Open or short										
Normal	Abnormal														
4.3kΩ~9.6kΩ	Open or short														
Vane motor 	Measure the resistance between the terminals using a tester. (Surrounding temperature 25°C) <table border="1"> <thead> <tr> <th colspan="4">Normal</th> <th>Abnormal</th> </tr> </thead> <tbody> <tr> <td>①-② Red-Pink</td> <td>①-③ Red-Blue</td> <td>①-④ Red-Orange</td> <td>①-⑤ Red-Yellow</td> <td rowspan="2">Open or short</td> </tr> <tr> <td colspan="4">200Ω ±7%</td> </tr> </tbody> </table>	Normal				Abnormal	①-② Red-Pink	①-③ Red-Blue	①-④ Red-Orange	①-⑤ Red-Yellow	Open or short	200Ω ±7%			
Normal				Abnormal											
①-② Red-Pink	①-③ Red-Blue	①-④ Red-Orange	①-⑤ Red-Yellow	Open or short											
200Ω ±7%															
Fan motor 	① Measure the resistance between the terminals using a tester. (Surrounding temperature 20°C) <table border="1"> <thead> <tr> <th></th> <th>Normal</th> <th>Abnormal</th> </tr> </thead> <tbody> <tr> <td>White-Black</td> <td>195Ω</td> <td rowspan="2">Open or short</td> </tr> <tr> <td>Red-Black</td> <td>200Ω</td> </tr> </tbody> </table> ② Without disassembling the parts, measure the electrical pressure of the gray wire (Signal line) and brown wire (GND) while the power is on. <table border="1"> <tbody> <tr> <td>Normal</td> <td>(1) At first, check if the electrical pressure is 12V between the brown wire (GND) and yellow wire (VCC). (2) Slowly start running the fan. It is normal if while the fan rotate once, the electrical pressure change from 0V to 12V then go back to 0V.</td> </tr> <tr> <td>Abnormal</td> <td>If the electrical pressure stay at around 0V or 10V, it means the fan motor has the defects.</td> </tr> </tbody> </table>		Normal	Abnormal	White-Black	195Ω	Open or short	Red-Black	200Ω	Normal	(1) At first, check if the electrical pressure is 12V between the brown wire (GND) and yellow wire (VCC). (2) Slowly start running the fan. It is normal if while the fan rotate once, the electrical pressure change from 0V to 12V then go back to 0V.	Abnormal	If the electrical pressure stay at around 0V or 10V, it means the fan motor has the defects.		
	Normal	Abnormal													
White-Black	195Ω	Open or short													
Red-Black	200Ω														
Normal	(1) At first, check if the electrical pressure is 12V between the brown wire (GND) and yellow wire (VCC). (2) Slowly start running the fan. It is normal if while the fan rotate once, the electrical pressure change from 0V to 12V then go back to 0V.														
Abnormal	If the electrical pressure stay at around 0V or 10V, it means the fan motor has the defects.														
Linear expansion valve 	Disconnect the connector then measure the resistance valve using a tester. (Coil temperature 20°C) <table border="1"> <thead> <tr> <th colspan="4">Normal</th> <th>Abnormal</th> </tr> </thead> <tbody> <tr> <td>(1)-(5) White-Red</td> <td>(2)-(6) Yellow-Brown</td> <td>(3)-(5) Orange-Red</td> <td>(4)-(6) Blue-Brown</td> <td rowspan="2">Open or short</td> </tr> <tr> <td colspan="4">150Ω ±10%</td> </tr> </tbody> </table>	Normal				Abnormal	(1)-(5) White-Red	(2)-(6) Yellow-Brown	(3)-(5) Orange-Red	(4)-(6) Blue-Brown	Open or short	150Ω ±10%			
Normal				Abnormal											
(1)-(5) White-Red	(2)-(6) Yellow-Brown	(3)-(5) Orange-Red	(4)-(6) Blue-Brown	Open or short											
150Ω ±10%															

<Thermistor Characteristic graph>

Thermistor for lower temperature

Room temperature thermistor (TH21)  
 Liquid pipe temperature thermistor (TH22)  
 Gas pipe temperature thermistor (TH23)

Thermistor  $R_0=15k\Omega \pm 3\%$   
 Fixed number of  $B=3480K \pm 2\%$

$$R_t = 15 \exp \left\{ 3480 \left( \frac{1}{273+t} - \frac{1}{273} \right) \right\}$$

0°C	15kΩ
10°C	9.6kΩ
20°C	6.3kΩ
25°C	5.4kΩ
30°C	4.3kΩ
40°C	3.0kΩ

< Thermistor for lower temperature >

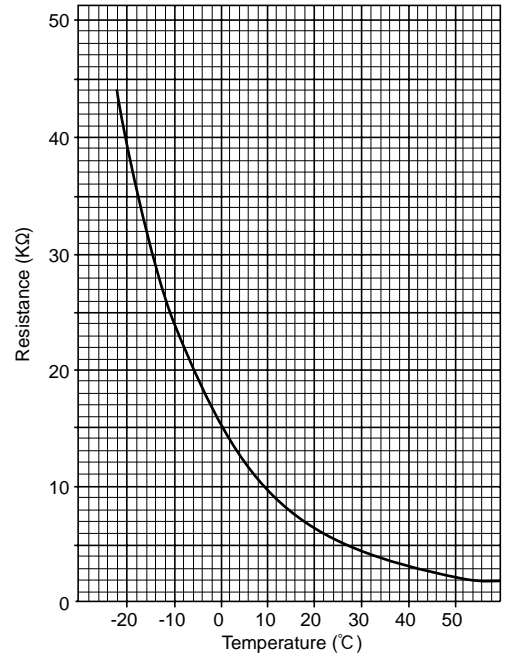

Linear expansion valve

① Operation summary of the linear expansion valve.

- Linear expansion valve open/close through stepping motor after receiving the pulse signal from the indoor controller board.
- Valve position can be changed in proportion to the number of pulse signal.

<Connection between the indoor controller board and the linear expansion valve>

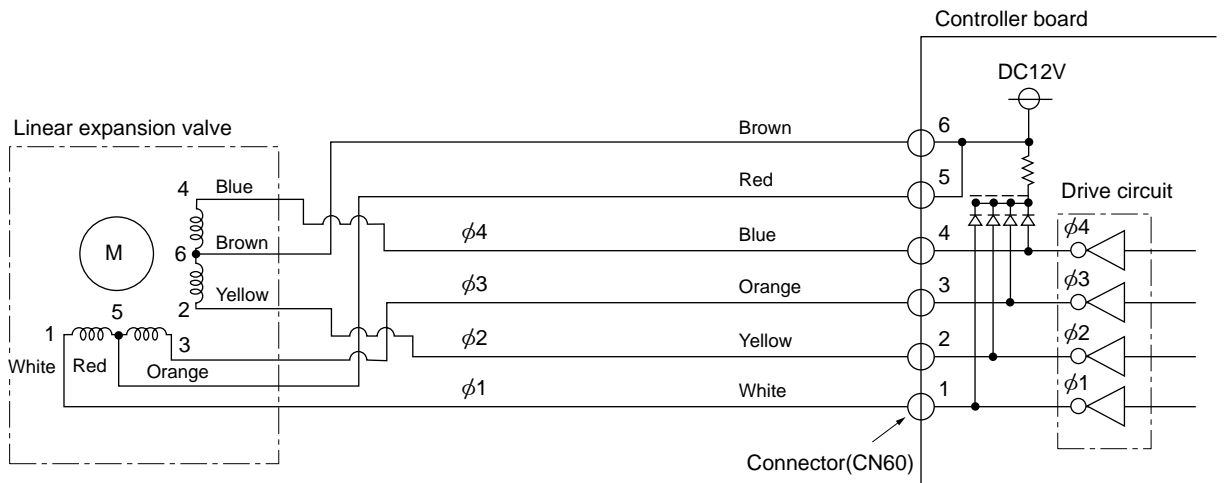

Note : Since the number of the connector at the controller board side and the relay connector are different, follow the color of the lead wire.

### <Output pulse signal and the valve operation>

Output (Phase)	Output			
	1	2	3	4
$\phi 1$	ON	OFF	OFF	ON
$\phi 2$	ON	ON	OFF	OFF
$\phi 3$	OFF	ON	ON	OFF
$\phi 4$	OFF	OFF	ON	ON

Closing a valve : 1 → 2 → 3 → 4 → 1  
 Opening a valve : 4 → 3 → 2 → 1 → 4

The output pulse shift in above order.

- \* 1. When linear expansion valve operation stops, all output phase become OFF.
- 2. At phase interruption or when phase does not shift in order, motor does not rotate smoothly and motor lock, and vibrates.

#### ② Linear expansion valve operation

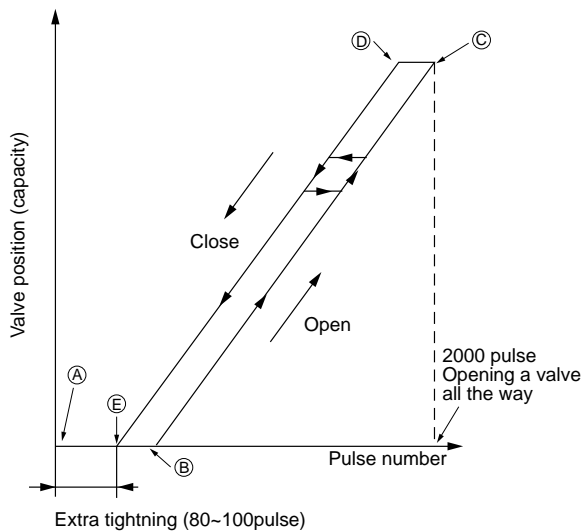

- \* When the switch is turned on, 2200 pulse closing valve signal will be send till it goes to ④ point in order to define the valve position.

When the valve move smoothly, there is no noise or vibration occurring from the linear expansion valve ; however, when the pulse number moves from ③ to ④ or when the valve is locked, more noise can be heard than normal situation.







- \* Noise can be detected by placing the ear against the screw driver handle while putting the screw driver to the linear expansion valve.

#### ③ Trouble shooting



Symptom	Check points	Countermeasures
Operation circuit failure of the micro processor.	Disconnect the connector on the controller board, then connect LED for checking.                                          Pulse signal will be sent out for 10 seconds as soon as the main switch is turn on. If there is LED with lights on or lights off, it means the operation circuit is abnormal.	Exchange the indoor controller board at drive circuit failure.
Linear expansion valve mechanism is locked.	Motor will idle and make ticking noise when motor is operated while the linear expansion valve is locked. This ticking sound is the sign of the abnormality.	Exchange the linear expansion valve.
Short or breakage of the motor coil of the linear expansion valve.	Measure the resistance between the each coil (red-white, red-orange, brown-yellow, brown-blue) using a tester. It is normal if the resistance is in the range of 150Ω+10%.	Exchange the linear expansion valve.
Valve doesn't close completely (thermistor leaking).	To check the linear expansion valve, operate the indoor unit in fan mode and at the same time operate other indoor units in cooling mode, then check the pipe temperature <liquid pipe temperature> of the indoor unit by the outdoor multi controller board operation monitor. During fan operation, linear expansion valve is closed completely and if there are some leaking, detecting temperature of the thermistor will go lower. If the detected temperature is much lower than the temperature indicated in the remote controller, it means the valve is not closed all the way. It is not necessary to exchange the linear expansion valve, if the leakage is small and not making any trouble.	If large amount of thermistor is leaked, exchange the linear expansion valve.
Wrong connection of the connector or contact failure.	Check the color of lead wire and missing terminal of the connector.	Disconnect the connector at the controller board, then check the continuity.

## 7-2. FUNCTION OF DIP SWITCH

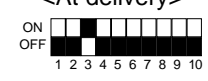
### PKFY-P20VAM-E PKFY-P25VAM-E

Switch	Pole	Function	Operation by switch		Remarks						
			ON	OFF							
SW1 Mode selection	1	Thermistor<Intake temperature> position	Built-in remote controller	Indoor unit	<div style="border: 1px solid black; padding: 5px; margin-bottom: 10px;">Address board</div> <At delivery>  NOTE: ※1 SW1-7=OFF, SW1-8=ON →Setting air flow. SW1-7=OFF, SW1-8=ON →Indoor fan stop. ※2 It is impossible to intake the fresh air.						
	2	Filter clogging	Provide	Not provide							
	3	Filter sign indication	2,500 hr	100 hr							
	4	Air intake ※2	Not effective	Not effective							
	5	Remote indication switching	Thermostat ON signal indication	Fan output indication							
	6	Humidifier control	Fan operation at Heating mode	Heat thermostat ON is operating							
	7	Air flow at heat thermostat	Low ※1	Extra low ※1							
	8	OFF	Setting air flow ※1	Reset to SW1-7							
	9	Auto restart function	Effective	Not effective							
	10	Power ON/OFF	Effective	Not effective							
SW2 Capacity code switch	1~4	<table border="1" style="width: 100%; text-align: center;"> <thead> <tr> <th>MODEL</th> <th>SW2</th> </tr> </thead> <tbody> <tr> <td>PKFY-P20VAM-E</td> <td>  </td> </tr> <tr> <td>PKFY-P25VAM-E</td> <td>  </td> </tr> </tbody> </table>			MODEL	SW2	PKFY-P20VAM-E		PKFY-P25VAM-E		<div style="border: 1px solid black; padding: 5px; margin-bottom: 10px;">Indoor controller board</div> Set while the unit is off. <At delivery> Set for each capacity.
		MODEL	SW2								
PKFY-P20VAM-E											
PKFY-P25VAM-E											
SW3 Function selection	1	Heat pump/Cool only	Cooling only	Heat pump	<div style="border: 1px solid black; padding: 5px; margin-bottom: 10px;">Indoor controller board</div> Set while the unit is off. <At delivery>  (Note 1) At cooling mode, each angle can be used only 1 hour.						
	2	Capacity save	Available	Not available							
	3	Vane	Available	Not available							
	4	Reading change of LEV opening on reversion of after defrosting	Not available	Available							
	5	Vane horizontal angle	Second setting	First setting							
	6	Vane cooling limit angle setting ※1	Horizontal angle	Down B,C							
	7	Indoor linear expansion valve opening	Effective	Not effective							
	8	Heater 4 degressed up	Not effective	Effective							
	9	Target Superheat setting temperature	9 degressed	6 degressed							
	10	Target Subcool setting temperature	15 degressed	10 degressed							

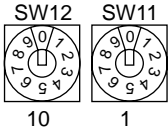
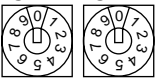

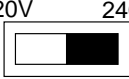
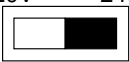
Switch		Operation by switch	Remarks
SW11 1st digit address setting SW12 2nd digit address setting	Rotary switch	 <p>Address setting should be done when M-NET remote controller is being used.</p>	<div style="border: 1px solid black; padding: 2px; width: fit-content; margin-bottom: 5px;">Address board</div> Address can be set while the unit is stopped. <At delivery> SW12 SW11 
SW14 Connection No. Setting	Rotary switch	 <p>This is the switch to be used when the indoor unit is operated with R2 series outdoor unit as a set.</p>	<div style="border: 1px solid black; padding: 2px; width: fit-content; margin-bottom: 5px;">Address board</div> <At delivery> SW14 
SW5 Voltage selection	2	 <p>If the unit is used at the 230V or 240V area, set the voltage to 240V.            If the unit is used at the 220V, set the voltage to 220V.</p>	<div style="border: 1px solid black; padding: 2px; width: fit-content; margin-bottom: 5px;">Address board</div> <At delivery> 



### 7-3. TEST POINT DIAGRAM

#### 7-3-1. Indoor controller board

PKFY-P20VAM-E

PKFY-P25VAM-E

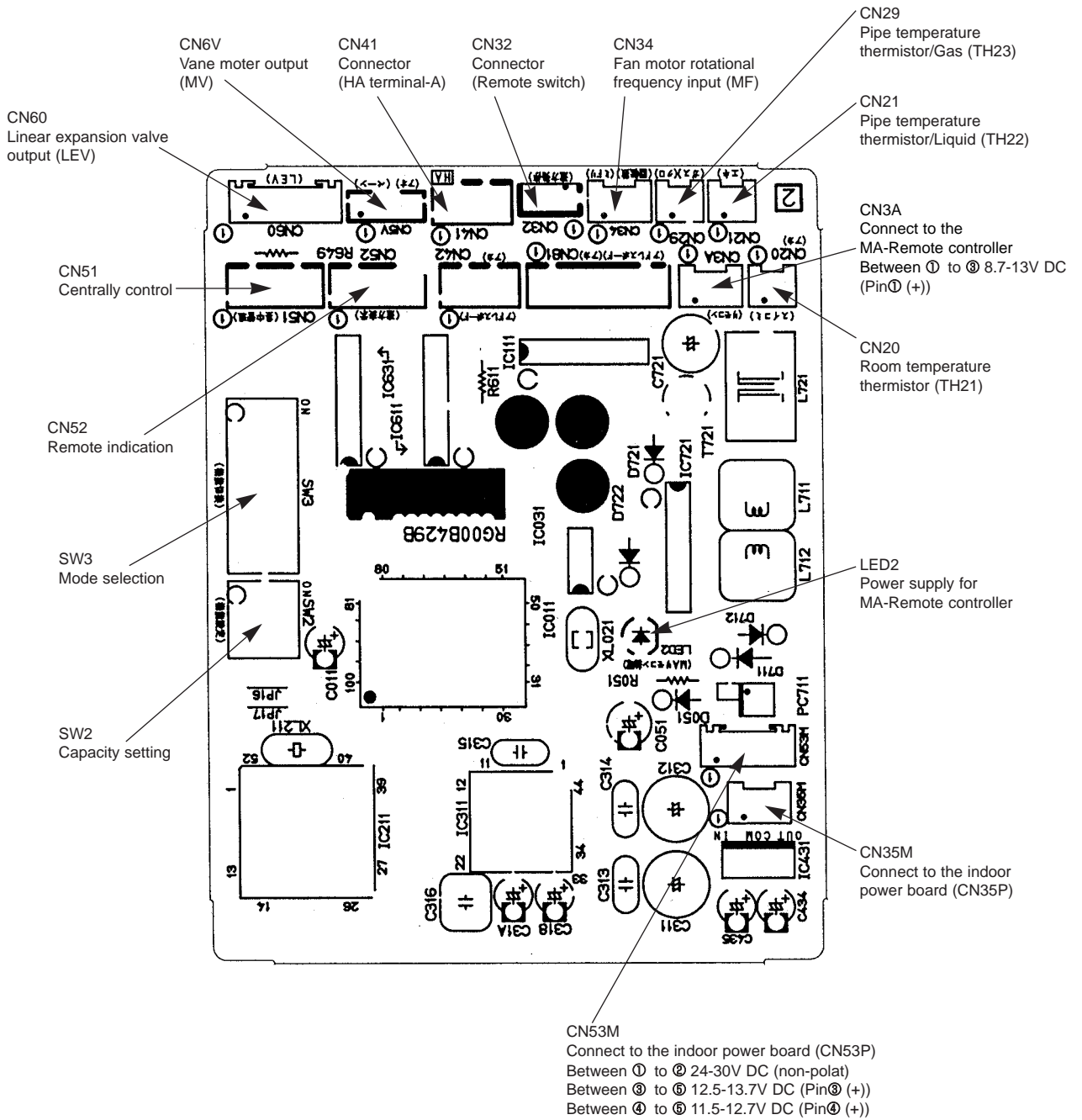

**7-3-2. Indoor power board**  
**PKFY-P20VAM-E**  
**PKFY-P25VAM-E**

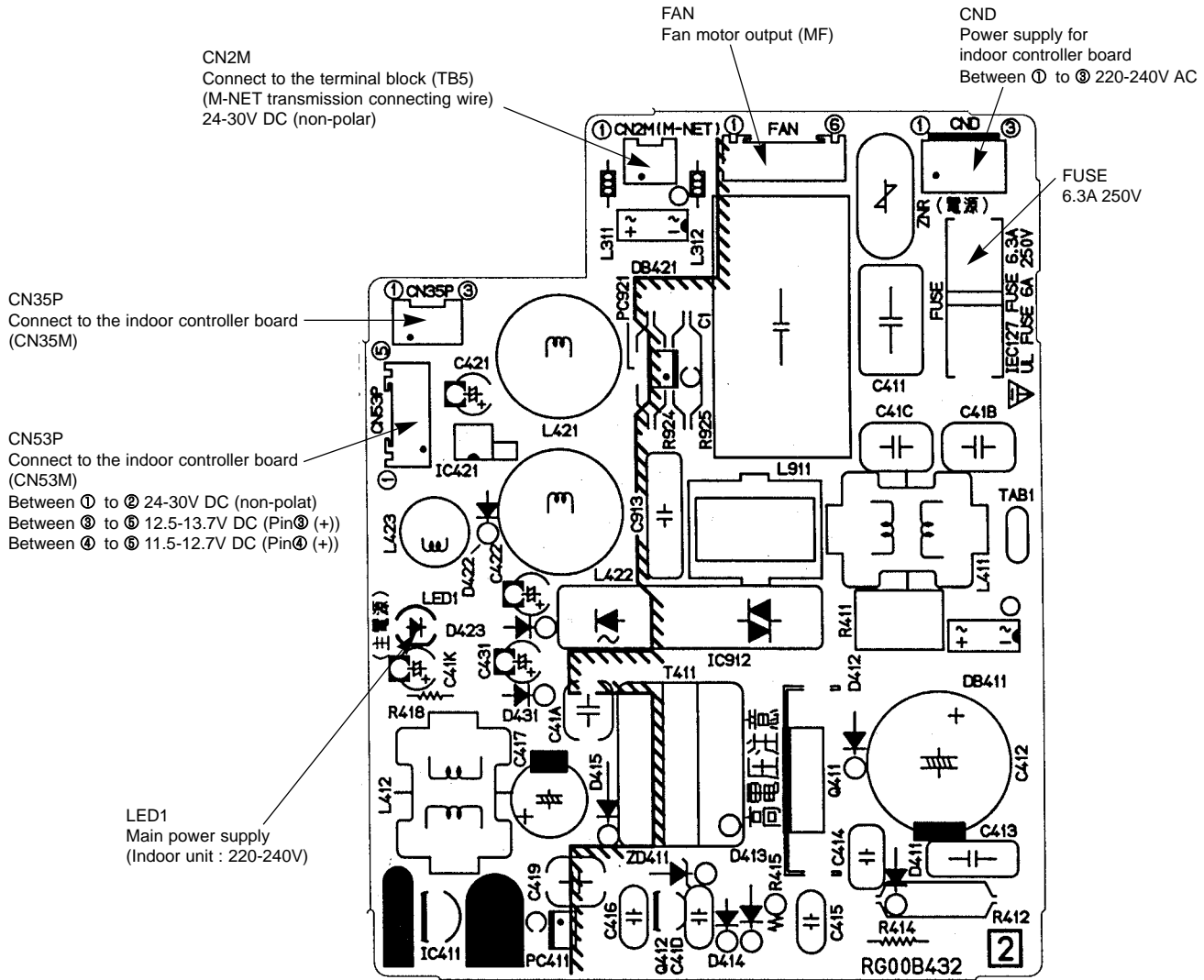

PKFY-P25VAM-E

Be careful on removing heavy parts.

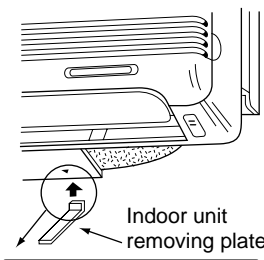
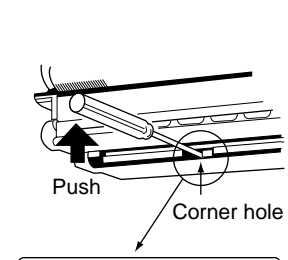
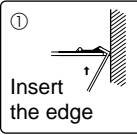
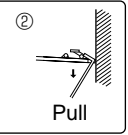
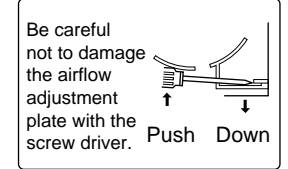
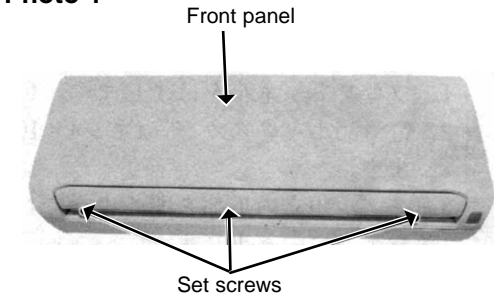
OPERATION PROCEDURE	PHOTOS & ILLUSTRATIONS
<p><b>1. REMOVING THE LOWER SIDE OF THE INDOOR UNIT FROM THE INSTALLATION PLATE</b></p> <p>When there is removing plate</p> <ol style="list-style-type: none"> <li>(1) Remove the corner box at right lower side of the indoor unit.</li> <li>(2) Insert the removing plate at the back side of the corner box to remove the indoor unit.</li> <li>(3) Remove the hook by pulling the lower side of the indoor unit down as shown in the figure 1.</li> </ol> <p>When there is no removing plate or it can not be used for some reason.</p> <ol style="list-style-type: none"> <li>(1) Remove the front panel.</li> <li>(2) Insert the screw driver to the corner hole at both left and right side as shown in the figure 2.</li> <li>(3) Push it up then, pull down the lower side of indoor unit and remove the hook.</li> </ol>	<div style="display: flex; justify-content: space-around;"> <div style="text-align: center;"> <p><b>Figure 1</b></p>  <p>Indoor unit removing plate</p> </div> <div style="text-align: center;"> <p><b>Figure 2</b></p>  <p>Push Corner hole</p> </div> </div> <div style="margin-top: 10px;">  <p>① Insert the edge      ② Pull</p> </div> <div style="margin-top: 10px; border: 1px solid black; padding: 5px;"> <p>Be careful not to damage the airflow adjustment plate with the screw driver.</p>  <p>Push      Down</p> </div>
<p><b>2. REMOVING THE FRONT PANEL</b></p> <p>※ Before removing the front panel, leave the open space at upper side of air flow adjustment plate approximately 2 to 3 cm.</p> <ol style="list-style-type: none"> <li>(1) Remove the screw caps then remove the set screws. (Refer to the photo 1)</li> <li>(2) Remove the left side of the front panel, then right side.</li> <li>(3) After removing the lower side of the front panel a little, remove it as pulling the upper side toward you.</li> </ol> <p>※ Please pay attention to the nozzle assemble.</p> <p><b>INSTALLING THE FRONT PANEL</b></p> <ol style="list-style-type: none"> <li>(1) Insert the lower side of the front panel under the air adjustment plate.</li> <li>(2) Set the upper side of the front panel.</li> <li>(3) Set the lower side of the front panel then fix it with the screws.</li> <li>(4) Press the area indicated as arrow sign and set it to the air conditioner unit.</li> </ol>	<p><b>Photo 1</b></p>  <p>Front panel Set screws</p> <p><b>Figure 3</b></p>  <p>④ Push Airflow adjustment plate ① ② ③</p>

## OPERATION PROCEDURE

## PHOTOS & ILLUSTRATIONS

### 3. REMOVING THE INDOOR MICRO CONTROLLER BOARD AND INDOOR POWER BOARD

- (1) Remove the front panel. (Refer to 2)
- (2) Remove the electrical box cover (screw 4 X 10).  
(Refer to the photo 2)

#### INDOOR MICRO CONTROLLER BOARD

- (1) Disconnect the following connectors on the indoor micro controller board.  
(connector in front of)
  - CN60, CN5V, CN34, CN29, CN21
  - CN42, CN81, CN3A, CN20
- (2) Pull out the indoor micro controller board toward you, then disconnect the rest of connectors.
  - CN53M, CN35M (See the photo 3)

#### INDOOR POWER BOARD

- (1) Disconnect the following connectors on the indoor power board.
  - FAN, CN53P, CN35P, CN2M, CND
- (2) Remove the screws of the indoor power board, then pull out the indoor power board toward you. (See the photo 3)

Photo 2

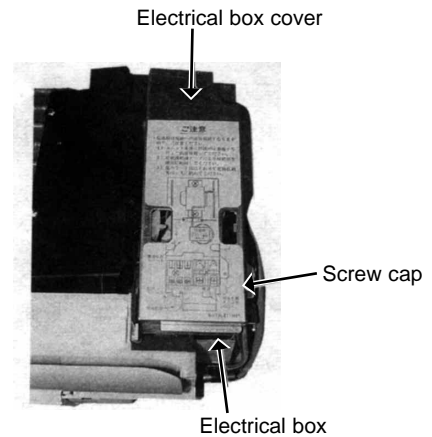
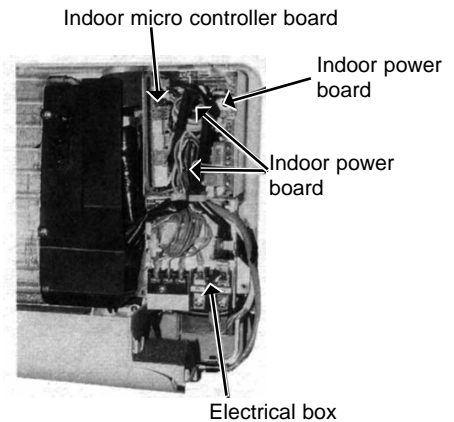

Photo 3



### 4. REMOVING THE ELECTRICAL BOX

- (1) Remove the front panel. (Refer to 2)
- (2) Remove the electrical box cover.
- (3) Pull the nozzle assembly toward you as opening the catch of the nozzle assembly.
- (4) Disconnect the indoor/outdoor connector.
- (5) Disconnect the following connector on the indoor micro controller board. (See the photo 4)
  - CN60, CN5V, CN34, CN29, CN21, CN20, CN3A
- (6) Disconnect the following connector on the indoor power board. (See the photo 4)
  - FAN, CN2M, CND
- (7) Disconnect the ground wire.
- (8) Pull the disconnected lead wire out from the electrical box.
- (9) Push up the upper fixture catch to remove the box, then pull the lower fixture and remove it from the box fixture.

Photo 4

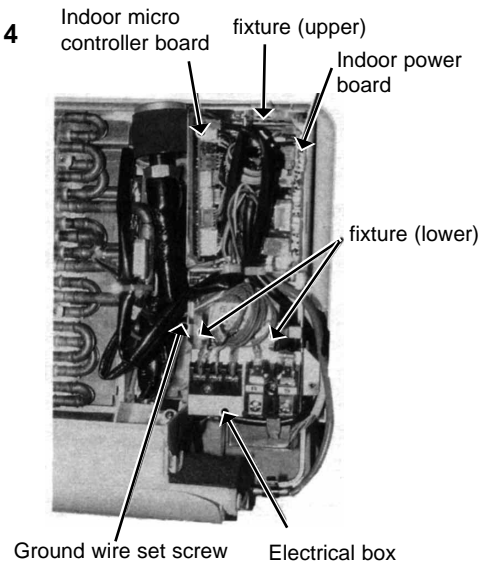



**OPERATION PROCEDURE**

**PHOTOS & ILLUSTRATIONS**

**5. REMOVING THE NOZZLE ASSEMBLY**

- (1) Remove the front panel (Refer to 2).
- (2) Remove the electrical box cover.
- (3) Disconnect the connector (CN5V) on the indoor micro controller board.
- (4) After unhook the right side of the corner box, press the upper left side and remove the corner box.
- (5) Remove the nozzle assemble from the fixture. (See the photo 5)
- (6) Remove the drain hose.

**Photo 5**

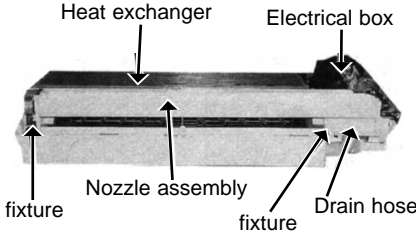

**6. REMOVING THE LINE FLOW FAN AND THE FAN MOTOR**

- (1) Remove the front panel. (Refer to 2)
- (2) Remove the nozzle assembly. (Refer to 5)
- (3) Remove the electrical parts box.
- (4) Remove the fixture while pressing the right side of motor fixture catch. (See the photo 6)
- (5) Remove the left side of the motor fixture.
- (6) Loosen the screw which fixes the line flow fan to the fan motor, then remove the fan motor by sliding it to the right side. (See the photo 6)
- (7) Pull the left-hand side of the heat exchanger toward you. (See the photo 7)
- (8) Remove the line flow fan.

**Photo 6**

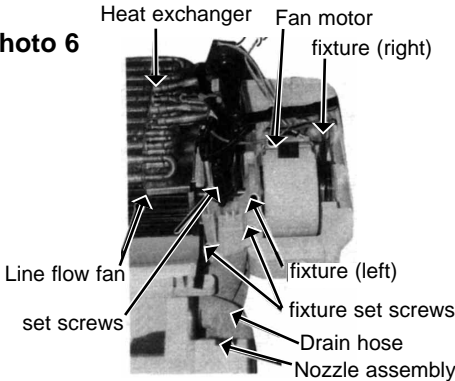

**Photo 7**

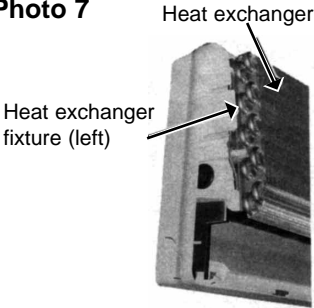

**7. REMOVING THE VANE MOTOR**

- (1) Remove the front panel.
- (2) Remove the screw of the electrical parts box cover, and remove the cover.
- (3) Remove the screw of the vane motor, and remove the motor from the shaft.
- (4) Disconnect the vane motor connector (CN5V) on the indoor controller board.

**Photo 8**

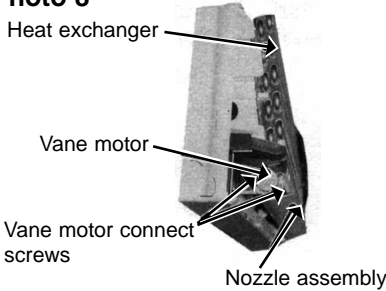

**8. REMOVING THE LIQUID PIPE THERMISTOR AND GAS PIPE THERMISTOR**

- (1) Remove the front panel. (Refer to 2)
- (2) Remove the electrical box cover.
- (3) Remove the pipe cover.
- (4) Cut the wiring fixed band.
- (5) Remove the liquid pipe thermistor and gas pipe thermistor. (See the photo 9)
- (6) Disconnect the connector (CN29) (CN21) on the indoor micro controller board.

**Photo 9**

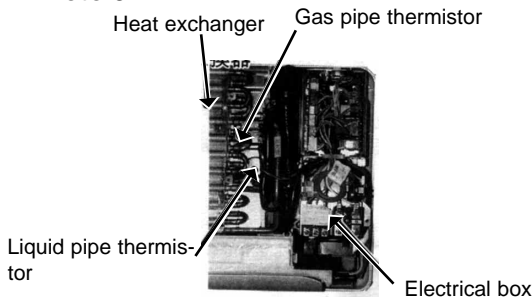

PANEL PARTS  
PKFY-P20VAM-E  
PKFY-P25VAM-E

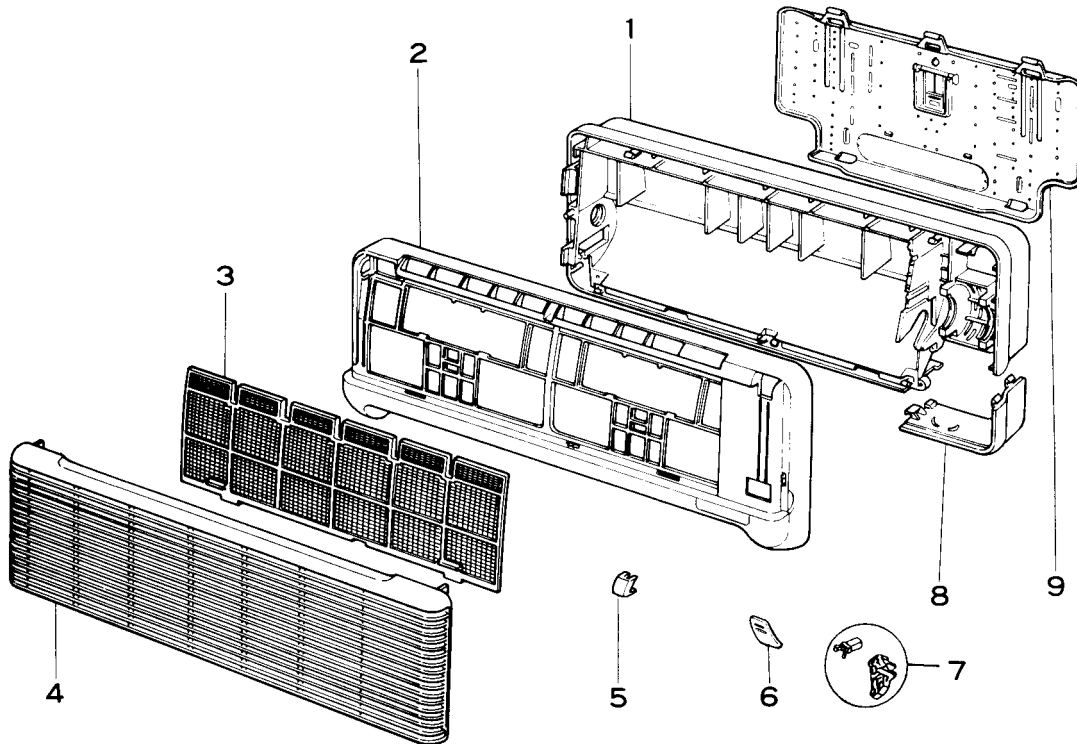

Part number that is circled is not shown in the figure.

No.	Parts No.	Parts Name	Specifications	Q'ty / set	Remarks (Drawing No.)	Wiring Diagram Symbol	Recom- mended Q'ty	Price	
				PKFY-P20VAM-E PKFY-P25VAM-E				Unit	Amount
1	R01 22A 635	BOX		1					
2	R01 22A 651	FRONT PANEL		1					
3	R01 22A 500	AIR FILTER		1					
4	R01 22A 691	INTAKE GRILLE		1					
5	R01 22A 096	SCREW CAP		1	3PCS/SET				
6	—	RECEIVING COVER		1	(DT25C174H03)				
7	R01 22A 054	GRILLE CATCH		1					
8	T7W A00 658	CORNER BOX		1					
9	R01 22A 808	BACK PLATE		1					
⑩	—	BRAND LABEL		1	(BC79R798H02)				

## ELECTRICAL PARTS PKFY-P20VAM-E PKFY-P25VAM-E

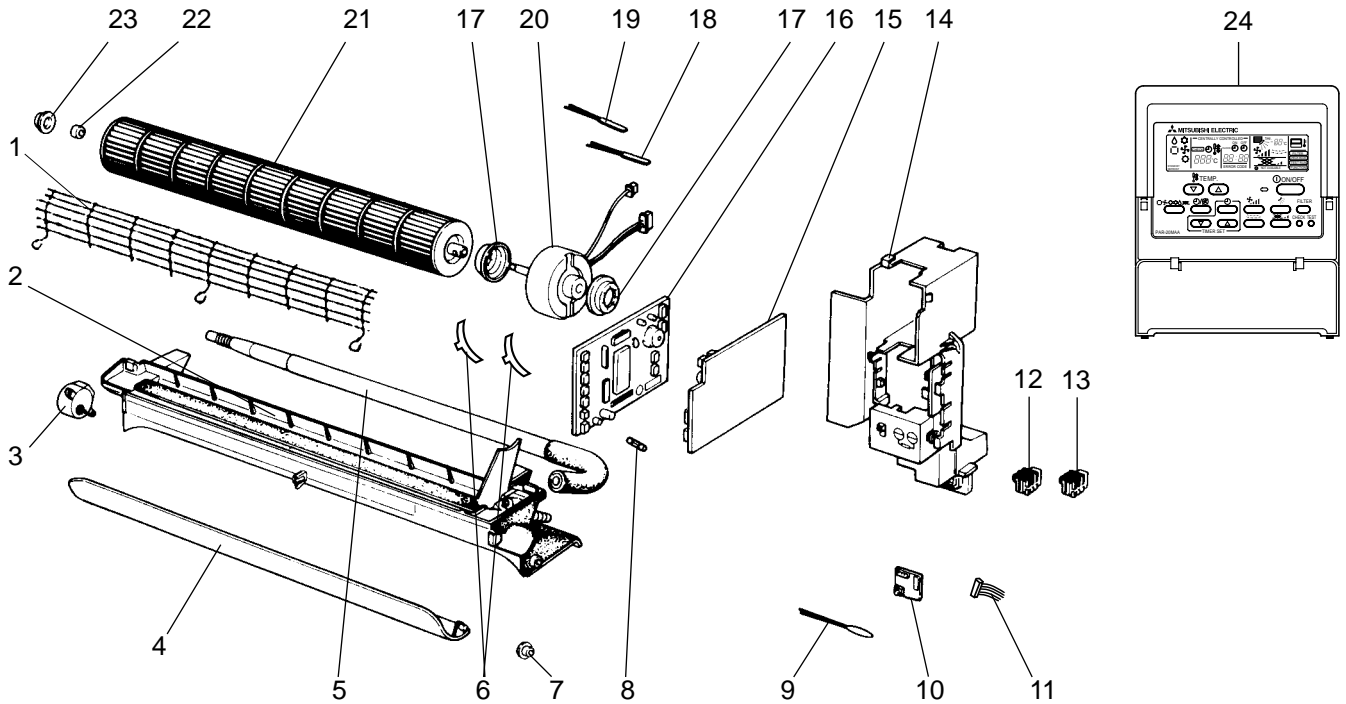

No.	Parts No.	Parts Name	Specifications	Q'ty / set		Remarks (Drawing No.)	Wiring Diagram Symbol	Recom- mended Q'ty	Price	
				PKFY- P20VAM-E	PKFY- P25VAM-E				Unit	Amount
1	T7W B00 675	FAN GUARD		1	1					
2	R01 22A 530	NOZZLE		1	1					
3	R01 22A 223	VANE MOTOR		1	1		MV			
4	R01 22A 002	AUTO VANE		1	1					
5	R01 22A 527	DRAIN HOSE		1	1					
6	R01 22A 126	MOTOR BAND	SET (LEFT, RIGHT)	1	1					
7	R01 07Y 092	VANE SLEEVE		1	1					
8	T7W 520 239	FUSE	250V 6.3A	1	1		FUSE			
9	T7W E12 202	ROOM TEMPERATURE THERMISTOR		1	1		TH21			
10	T7W B01 294	ADDRESS BOARD		1	1		A.B			
11	T7W E00 304	ADDRESS CABLE		1	1					
12	T7W 512 716	TERMINAL BLOCK	2P (M1, M2)	1	1		TB5			
13	T7W E05 716	TERMINAL BLOCK	3P (L, N, ⊕)	1	1		TB2			
14	—	ELECTRICAL BOX		1	1	(BG00J285G24)				
15	T7W E03 313	POWER BOARD		1	1		P.B			
16	R01 H17 310	INDOOR CONTROLLER BOARD		1	1		M.B			
17	R01 22A 105	RUBBER MOUNT		2	2					
18	R01 E38 202	PIPE TEMPERATURE THERMISTOR	GAS	1	1		TH23			
19	T7W E06 202	PIPE TEMPERATURE THERMISTOR	LIQUID	1	1		TH22			
20	T7W E11 762	FAN MOTOR	PS4V17-KA	1	1		MF			
21	R01 22A 114	LINE FLOW FAN		1	1					
22	R01 005 103	SLEEVE BEARING		1	1					
23	R01 22A 102	BEARING MOUNT		1	1					
24	—	REMOTE CONTROLLER	PAR-20MAA	1	1		R.B			

**HEAT EXCHANGER PARTS**  
**PKFY-P20VAM-E**  
**PKFY-P25VAM-E**

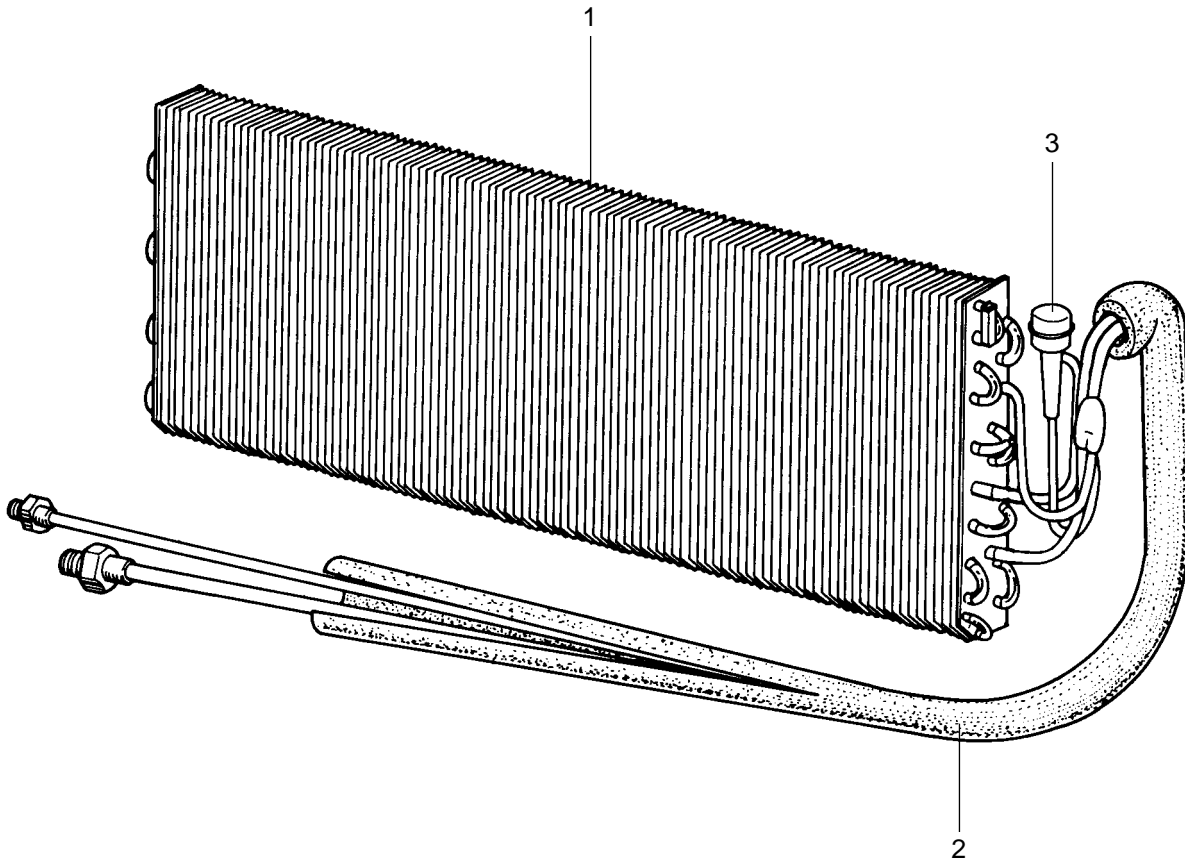

No.	Parts No.	Parts Name	Specifications	Q'ty / set		Remarks (Drawing No.)	Wiring Diagram Symbol	Recom- mended Q'ty	Price	
				PKFY- P20VAM-E	PKFY- P25VAM-E				Unit	Amount
1	R01 H58 480	HEAT EXCHANGER		1						
	R01 H59 480	HEAT EXCHANGER			1					
2	R01 E03 470	CONNECT PIPE		1	1					
3	R01 E63 401	LINEAR EXPANSION VALVE		1	1		LEV			

**MITSUBISHI ELECTRIC CORPORATION**

HEAD OFFICE : MITSUBISHI DENKI BLDG., 2-2-3, MARUNOUCHI, CHIYODA-KU TOKYO 100-8310, JAPAN