



Air-Conditioners

2007

TECHNICAL & SERVICE MANUAL

Models PFFY-P20VLRMM-E, PFFY-P40VLRMM-E
PFFY-P25VLRMM-E, PFFY-P50VLRMM-E
PFFY-P32VLRMM-E, PFFY-P63VLRMM-E

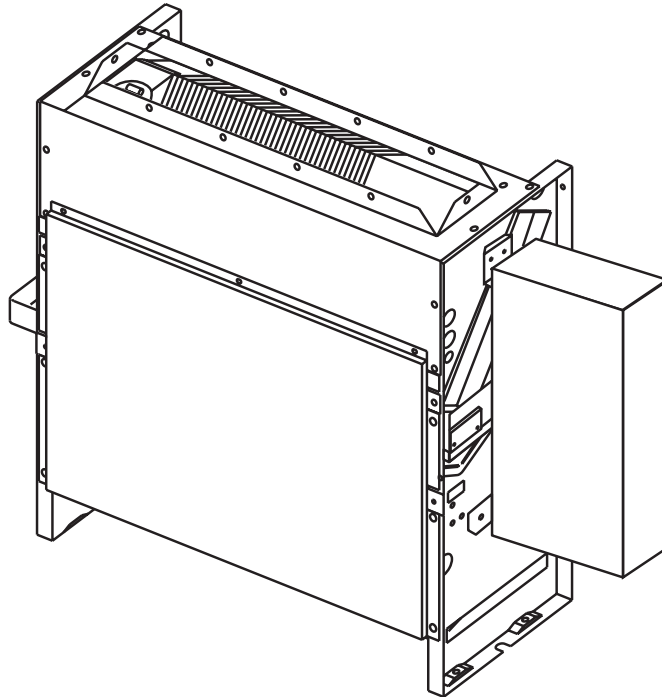

CITY MULTI

For use with the R410A

Safety Precautions

Read before installation and performing electrical work

- Thoroughly read the following safety precautions prior to installation.
- Observe these safety precautions for your safety.
- This equipment may have adverse effects on the equipment on the same power supply system.
- Contact the local power authority before connecting to the system.

Symbol explanations



WARNING

This symbol indicates that failure to follow the instructions exactly as stated poses the risk of serious injury or death.



CAUTION

This symbol indicates that failure to follow the instructions exactly as stated poses the risk of serious injury or damage to the unit.



Indicates an action that must be avoided.



Indicates important instructions.



Indicates a parts that requires grounding.



Indicates that caution must be taken with rotating parts. (This symbol is on the main unit label.) <Color: Yellow>



Indicates that the parts that are marked with this symbol pose a risk of electric shock. (This symbol is on the main unit label.) <Color: Yellow>



WARNING

Carefully read the labels affixed to the main unit.



WARNING

Ask your dealer or a qualified technician to install the unit.

Improper installation by the user may result in water leakage, electric shock, or fire.

Properly install the unit on a surface that can withstand its weight.

Unit installed on an unstable surface may fall and cause injury.

Only use specified cables. Securely connect each cable so that the terminals do not carry the weight of the cable.

Improperly connected cables may produce heat and start a fire.

Take appropriate safety measures against wind gusts and earthquakes to prevent the unit from toppling over.

Improper installation may cause the unit to topple over and cause injury or damage to the unit.

Do not make any modifications or alterations to the unit. Consult your dealer for repair.

Improper repair may result in water leakage, electric shock, or fire.

Do not touch the heat exchanger fins with bare hands.

The fins are sharp and pose a risk of cuts.

In the event of a refrigerant leak, thoroughly ventilate the room.

If gaseous refrigerant leaks out and comes in contact with an open flame, toxic gases will be generated.

Properly install the unit according to the instructions in the Installation Manual.

Improper installation may result in water leakage, electric shock, or fire.

Have all electrical work performed by an authorized electrician according to the local regulations and the instructions in this manual. Use a dedicated circuit.

Insufficient power supply capacity or improper installation of the unit may result in malfunctions of the unit, electric shock, or fire.

WARNING

Keep electrical parts away from water.

Wet electrical parts pose a risk of electric shock, smoke, or fire.

Securely attach the control box cover.

If the cover is not installed properly, dust or water may infiltrate and pose a risk of electric shock, smoke, or fire.

Only use the type of refrigerant that is indicated on the unit when installing or relocating the unit.

Infiltration of any other types of refrigerant or air into the unit may adversely affect the refrigerant cycle and may cause the pipes to burst or explode.

When installing the unit in a small space, take appropriate precautions to prevent leaked refrigerant from reaching the limiting concentration.

Leaked refrigerant gas will displace oxygen and may cause oxygen starvation. Consult your dealer before installing the unit.

Consult your dealer or a qualified technician when moving or reinstalling the unit.

Improper installation may result in water leakage, electric shock, or fire.

After completing the service work, check for a refrigerant leak.

If leaked refrigerant is exposed to a heat source, such as a fan heater, stove, or electric grill, toxic gases will be generated.

Do not try to defeat the safety features of the unit.

Forced operation of the pressure switch or the temperature switch by defeating the safety features for these devices, or the use of accessories other than the ones that are recommended by Mitsubishi Electric may result in smoke, fire, or explosion.

Consult your dealer for proper disposal method.

Do not use a leak detection additive.

Precautions for handling units for use with R410A

CAUTION

Do not use the existing refrigerant piping.

A large amount of chlorine that may be contained in the residual refrigerant and refrigerator oil in the existing piping may cause the refrigerator oil in the new unit to deteriorate.

Use refrigerant piping materials made of phosphorus deoxidized copper. Keep the inner and outer surfaces of the pipes clean and free of such contaminants as sulfur, oxides, dust, dirt, shaving particles, oil, and moisture.

Contaminants in the refrigerant piping may cause the refrigerator oil to deteriorate.

Store the piping materials indoors, and keep both ends of the pipes sealed until immediately before brazing. (Keep elbows and other joints wrapped in plastic.)

Infiltration of dust, dirt, or water into the refrigerant system may cause the refrigerator oil to deteriorate or cause the compressor to malfunction.

Charge the system with refrigerant in the liquid phase.

If gaseous refrigerant is drawn out of the cylinder first, the composition of the remaining refrigerant in the cylinder will change and become unsuitable for use.

Only use R410A.

The use of other types of refrigerant that contain chloride may cause the refrigerator oil to deteriorate.

Use a vacuum pump with a check valve.

If a vacuum pump that is not equipped with a check valve is used, the vacuum pump oil may flow into the refrigerant cycle and cause the refrigerator oil to deteriorate.

Prepare tools for exclusive use with R410A. Do not use the following tools if they have been used with the conventional refrigerant: gauge manifold, charging hose, gas leak detector, check valve, refrigerant charge base, vacuum gauge, and refrigerant recovery equipment.

If the refrigerant or the refrigerator oil that may be left on these tools are mixed in with R410A, it may cause the refrigerator oil in the new system to deteriorate.

Infiltration of water may cause the refrigerator oil to deteriorate. Leak detectors for conventional refrigerants will not detect an R410A leak because R410A is free of chlorine.

Do not use a charging cylinder.

If a charging cylinder is used, the composition of the refrigerant in the cylinder will change and become unsuitable for use.

Exercise special care when handling tools for use with R410A.

Infiltration of dust, dirt, or water into the refrigerant system may cause the refrigerator oil to deteriorate.

CONTENTS

I Features

[1] Features.....	1
-------------------	---

II Components and Functions

[1] Components and Functions.....	2
-----------------------------------	---

III Specifications

[1] Specifications.....	4
1.Specifications	4
2.Electrical component specifications.....	6

IV Outlines and Dimensions

[1] Outlines and Dimensions.....	7
----------------------------------	---

V Wiring Diagram

[1] Wiring Diagram.....	8
-------------------------	---

VI Refrigerant System Diagram

[1] Refrigerant system diagram.....	10
-------------------------------------	----

VII Troubleshooting

[1] Troubleshooting	11
1.Check methods.....	11
2.DC fan motor (fan motor/indoor control board).....	15
3.Address switch setting.....	16
4.Voltage test points on the control board.....	17
5.Dipswitch setting (Factory setting).....	18

VIII Disassembly Procedure

[1] Disassembly Procedure.....	21
1.Control box	21
2.Thermistor (Intake air)	22
3.Drainpan	23
4.Thermistor (Gas pipe) (Liquid pipe).....	25
5.Fan and fan motor	26
6.Heat exchanger	27



[1] Features

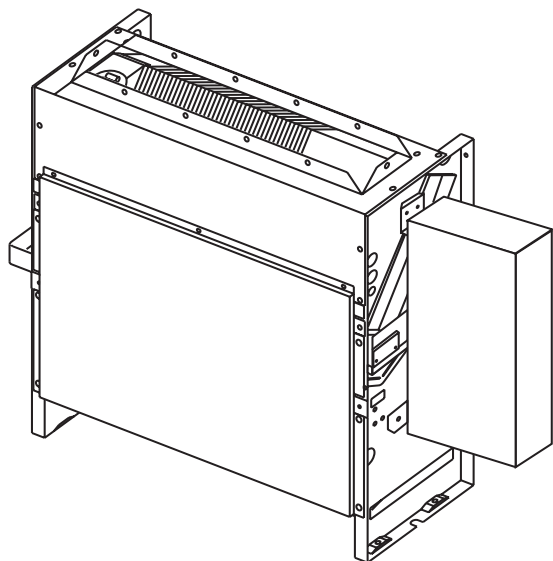

Model	Cooling capacity/Heating capacity
	kW
PFFY-P20VLRMM-E	2.2/2.5
PFFY-P25VLRMM-E	2.8/3.2
PFFY-P32VLRMM-E	3.6/4.0
PFFY-P40VLRMM-E	4.5/5.0
PFFY-P50VLRMM-E	5.6/6.3
PFFY-P63VLRMM-E	7.1/8.0

[1] Components and Functions

1. Indoor (Main) Unit

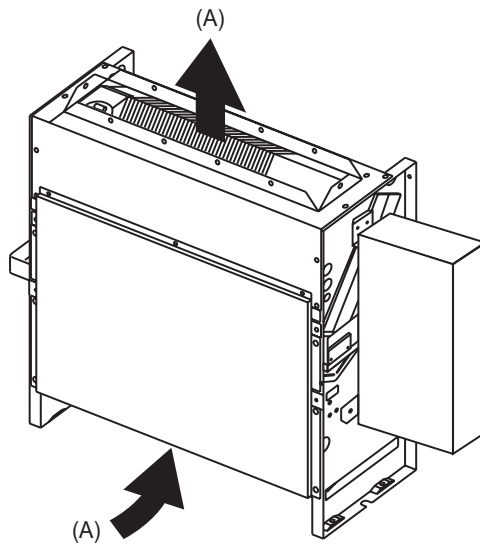

(A) Air

2. Remote Controller

[PAR-21MAA]

Once the operation mode is selected, the unit will remain in the selected mode until changed.

(1) Remote Controller Buttons

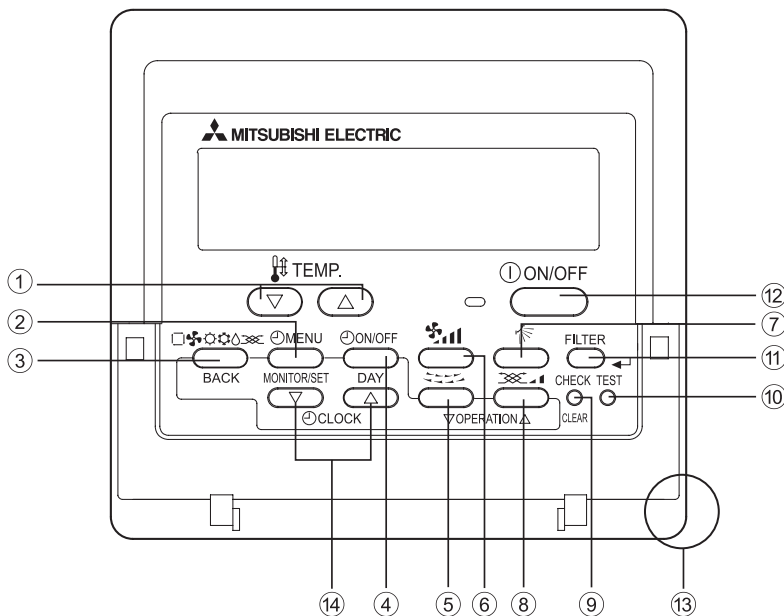

- | | |
|----------------------------|---|
| 1 [Set Temperature] Button | 7 [Vane Control] Button |
| 2 [Timer Menu] Button | 8 [Ventilation] Button |
| [Monitor/Set] Button | [Operation] Button |
| 3 [Mode] Button | 9 [Check/Clear] Button |
| [Back] Button | 10 [Test Run] Button |
| 4 [Timer On/Off] Button | 11 [Filter] Button |
| [Set Day] Button | [↵] Button |
| 5 [Louver] Button | 12 [ON/OFF] Button |
| [Operation] Button | 13 Position of built-in room thermistor |
| 6 [Fan Speed] Button | 14 [Set Time] Button |

- Keep the remote controller out of direct sunlight to ensure accurate measurement of room temperature.
- The thermistor at the lower right-hand section of the remote controller must be free from obstructions to ensure accurate measurement of room temperature.

(2) Remote Controller Display

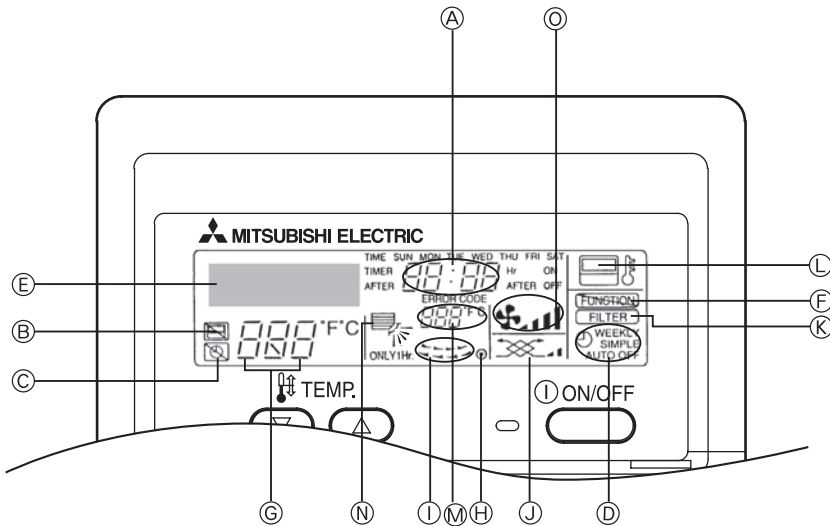

- | | | | |
|---|---|---|------------------|
| A | Current time/Timer time | I | Louver swing |
| B | Centralized control indicator | J | Ventilation |
| C | Timer OFF indicator | K | Filter sign |
| D | Timer mode | L | Sensor position |
| E | Operation mode display: COOL, DRY, AUTO, FAN, HEAT | M | Room temperature |
| F | Function Lock indicator | N | Vane setting |
| G | Preset temperature | O | Fan speed |
| H | Power indicator | | |

[1] Specifications**1. Specifications**

Model			PFFY-P20VLRMM-E	PFFY-P25VLRMM-E	PFFY-P32VLRMM-E
Power supply	Voltage	V	220-240		
	Frequency	Hz	50/60		
Cooling capacity *1		kW	2.2	2.8	3.6
Heating capacity *1		kW	2.5	3.2	4.0
Power consumption	Cooling	kW	0.04/0.04	0.04/0.04	0.04/0.04
	Heating	kW	0.04/0.04	0.04/0.04	0.04/0.04
Current consumption	Cooling	A	0.34/0.33	0.34/0.33	0.38/0.37
	Heating	A	0.34/0.33	0.34/0.33	0.38/0.37
External finish (Munsel No.)			Galvanized steel plate		
Dimensions	Height	mm	639		
	Width	mm	886	1006	
	Depth	mm	220		
Net weight *2		kg	18.5	18.5	20
Heat exchanger			Cross fin (Aluminium fin and copper tube)		
Fan	Type		Sirocco fan x 1		Sirocco fan x 2
	Airflow rate (Low-Mid-High)	m ³ /min	4.5-5.5-6.5	4.5-5.5-6.5	6.5-7.5-9.0
	External static pressure	Pa	20-40-60		
Motor	Output	kW	0.096	0.096	0.096
Air filter			PP Honeycomb fabric		
Refrigerant pipe dimensions	Gas (Brazed connection)	mm [in.]	ø12.7 [ø1/2]		
	Liquid (Brazed connection)	mm [in.]	ø6.35 [ø1/4]		
Drain pipe dimensions		mm [in.]	Accessory hose ø27 [1-3/32] (top end : ø20 [13/16])		
Operating noise (Low-Mid-High)	20Pa	dB (A)	31-36-40	31-36-40	27-32-37
	40Pa		34-39-42	34-39-42	30-35-41
	60Pa		35-40-43	35-40-43	32-37-42

*1 Cooling/Heating capacity indicates the maximum value at operation under the following condition.
 <Cooling> Indoor temperature: 27°CDB/19°CWB (81°FDB/66°F WB) Outdoor temperature: 35°CDB (95°FDB)
 <Heating> Indoor temperature: 20°CDB (68°FDB) Outdoor temperature: 7°CDB/6°CWB (45°FDB/43°F WB)
 Pipe length: 7.5m (24-9/16ft) Height difference: 0m (0ft)

*2 The external static pressure is set to 20Pa at factory shipment.

*3 The actual capacity characteristics vary with the combination of indoor and outdoor units. See the technical information.

*4 The noise level in operation is measured at 1m apart from the front side and the bottom side of the unit in anechoic room. (Noise meter A-scale value) Connect the duct of 1m in length to the air outlet.

Model			PFFY-P40VLRMM-E	PFFY-P50VLRMM-E	PFFY-P63VLRMM-E
Power supply	Voltage	V	220-240		
	Frequency	Hz	50/60		
Cooling capacity *1		kW	4.5	5.6	7.1
Heating capacity *1		kW	5.0	6.3	8.0
Power consumption	Cooling	kW	0.05/0.05	0.05/0.05	0.07/0.07
	Heating	kW	0.05/0.05	0.05/0.05	0.07/0.07
Current consumption	Cooling	A	0.43/0.42	0.48/0.47	0.59/0.58
	Heating	A	0.43/0.42	0.48/0.47	0.59/0.58
External finish (Munsel No.)			Galvanized steel plate		
Dimensions	Height	mm	639		
	Width	mm	1006	1246	
	Depth	mm	220		
Net weight *2		kg	21	25	27
Heat exchanger			Cross fin (Aluminium fin and copper tube)		
Fan	Type		Sirocco fan x 2		
	Airflow rate (Low-Mid-High)	m ³ /min	8.0-9.5-11.0	10.0-12.0-14.0	11.0-13.0-15.5
	External static pressure		Pa	20-40-60	
Motor	Output	kW	0.096	0.096	0.096
Air filter			PP Honeycomb fabric		
Refrigerant pipe dimensions	Gas (Brazed connection)	mm [in.]	ø12.7 [ø1/2]		ø15.88 [ø5/8]
	Liquid (Brazed connection)	mm [in.]	ø6.35 [ø1/4]		ø9.52 [ø3/8]
Drain pipe dimensions		mm [in.]	Accessory hose ø27 [1-3/32] (top end : 20 [13/16])		
Operating noise (Low-Mid-High)	20Pa	dB (A)	30-36-40	32-37-41	35-40-44
	40Pa		32-38-42	35-40-44	36-42-47
	60Pa		35-39-44	36-41-45	38-43-48

*1 Cooling/Heating capacity indicates the maximum value at operation under the following condition.
 <Cooling> Indoor temperature: 27°CDB/19°CWB (81°FDB/66°F WB) Outdoor temperature: 35°CDB (95°FDB)
 <Heating> Indoor temperature: 20°CDB (68°FDB) Outdoor temperature: 7°CDB/6°CWB (45°FDB/43°F WB)
 Pipe length: 7.5m (24-9/16ft) Height difference: 0m (0ft)

*2 The external static pressure is set to 20Pa at factory shipment.

*3 The actual capacity characteristics vary with the combination of indoor and outdoor units. See the technical information.

*4 The noise level in operation is measured at 1m apart from the front side and the bottom side of the unit in anechoic room. (Noise meter A-scale value) Connect the duct of 1m in length to the air outlet.

2. Electrical component specifications

Component	Sym- bol	PFFY-P20VLRMM-E	PFFY-P25VLRMM-E	PFFY-P32VLRMM-E
Room temperature thermistor	TH21	Resistance 0°C/15k Ω, 10°C/9.6kΩ, 20°C/6.3kΩ, 25°C/5.4kΩ, 30°C/4.3kΩ, 40°C/3.0kΩ		
Liquid pipe thermistor	TH22	Resistance 0°C/15k Ω, 10°C/9.6kΩ, 20°C/6.3kΩ, 25°C/5.4kΩ, 30°C/4.3kΩ, 40°C/3.0kΩ		
Gas pipe thermistor	TH23	Resistance 0°C/15k Ω, 10°C/9.6kΩ, 20°C/6.3kΩ, 25°C/5.4kΩ, 30°C/4.3kΩ, 40°C/3.0kΩ		
Fuse	FUSE	250V 6.3A		
Fan motor		8-pole, Output 96W SIC-70CW-D896-3		8-pole, Output 96W SIC-70CW-D8114-4
Linear expansion valve	LEV	12VDC Stepping motor drive port diameter ø3.2 (0~1400 pulse)		
Power supply terminal block	TB2	(L, N, ⊕) 330V 30A		
Transmission terminal block	TB5 TB15	(1, 2), (M1, M2, S) 250V 20A		

Component	Sym- bol	PFFY-P40VLRMM-E	PFFY-P50VLRMM-E	PFFY-P63VLRMM-E
Room temperature thermistor	TH21	Resistance 0°C/15k Ω, 10°C/9.6kΩ, 20°C/6.3kΩ, 25°C/5.4kΩ, 30°C/4.3kΩ, 40°C/3.0kΩ		
Liquid pipe thermistor	TH22	Resistance 0°C/15k Ω, 10°C/9.6kΩ, 20°C/6.3kΩ, 25°C/5.4kΩ, 30°C/4.3kΩ, 40°C/3.0kΩ		
Gas pipe thermistor	TH23	Resistance 0°C/15k Ω, 10°C/9.6kΩ, 20°C/6.3kΩ, 25°C/5.4kΩ, 30°C/4.3kΩ, 40°C/3.0kΩ		
Fuse	FUSE	250V 6.3A		
Fan motor		8-pole, Output 96W SIC-70CW-D8114-4		
Linear expansion valve	LEV	12VDC Stepping motor drive port diameter ø3.2 (0~1400 pulse)		
Power supply terminal block	TB2	(L, N, ⊕) 330V 30A		
Transmission terminal block	TB5 TB15	(1, 2), (M1, M2, S) 250V 20A		

[1] Outlines and Dimensions

1. PFFY-P20, 25, 32, 40, 50, 63VLRMM-E

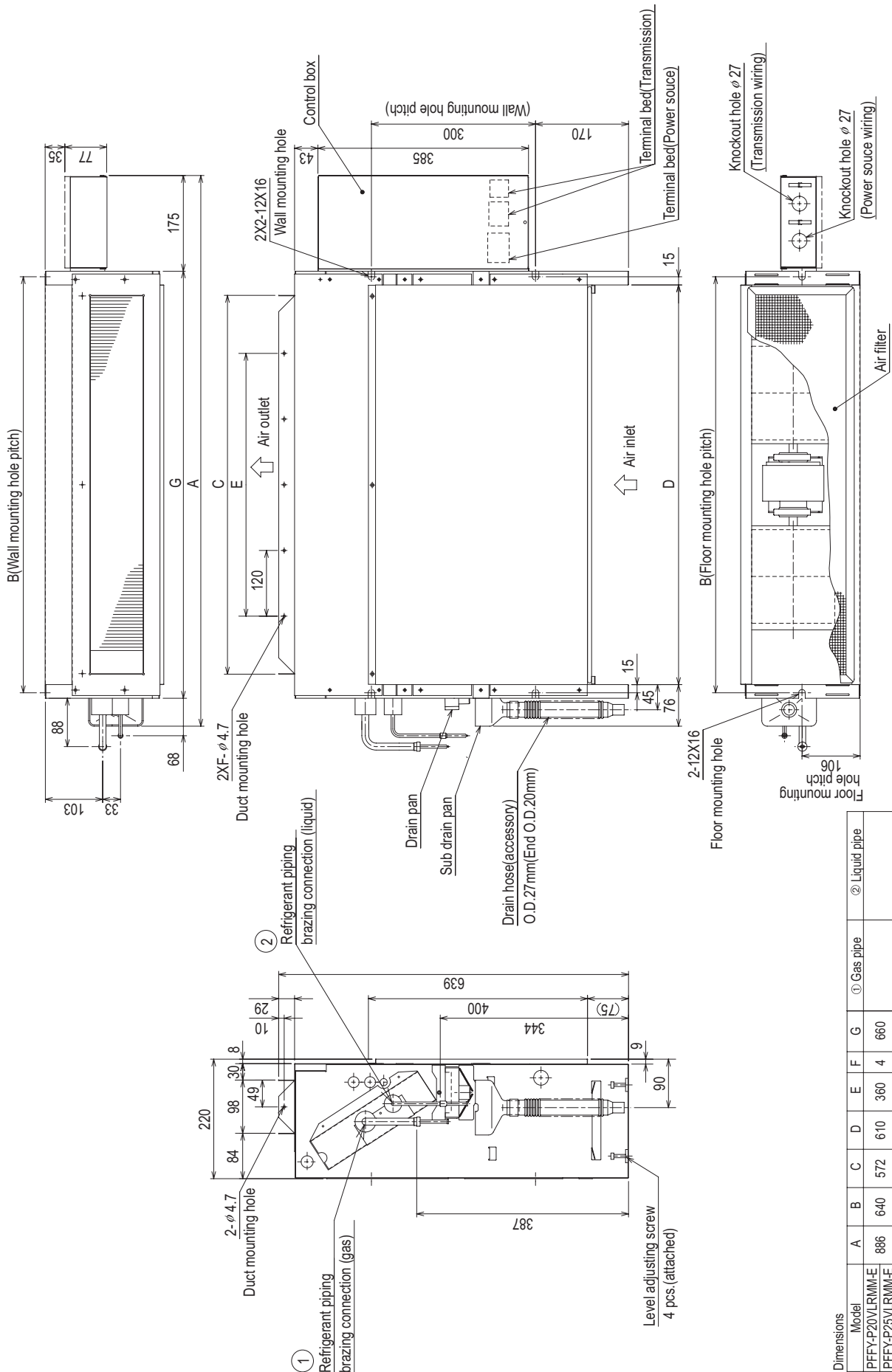

Dimensions		A	B	C	D	E	F	G	① Gas pipe	② Liquid pipe
Model										
PFFY-P20VLRMM-E	886	640	572	610	360	4	660			
PFFY-P25VLRMM-E										
PFFY-P32VLRMM-E	1006	760	692	730	480	5	780	φ12.7		φ6.35
PFFY-P40VLRMM-E										
PFFY-P50VLRMM-E	1246	1000	932	970	720	7	1020	φ15.88		φ9.52
PFFY-P63VLRMM-E										

[1] Wiring Diagram

1. PFFY-P20,25,32,40,50,63VLRMM-E

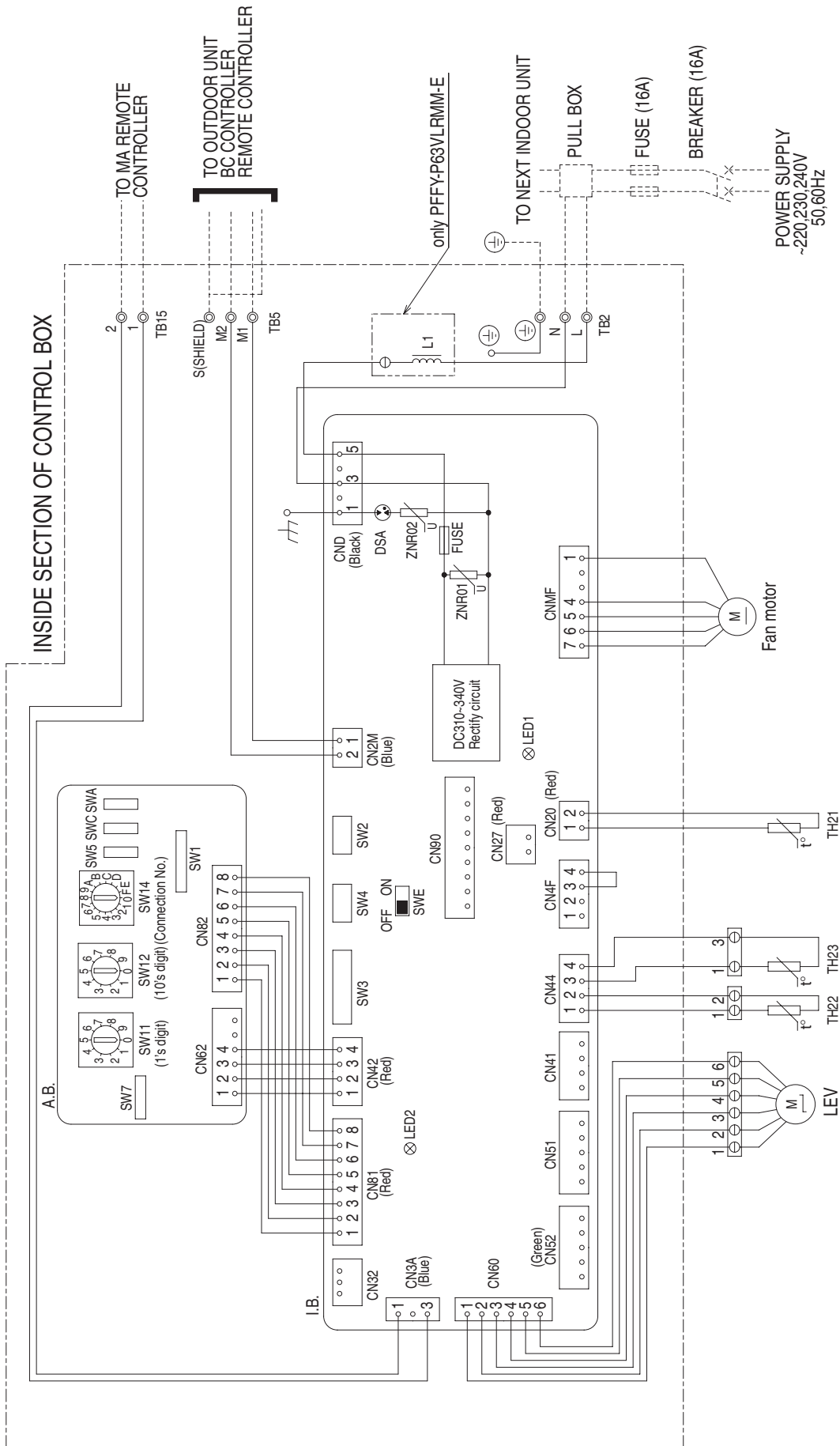

Table.1 SYMBOL EXPLANATION

SYM-BOL	NAME	SYM-BOL	NAME	SYM-BOL	NAME
I.B.	Indoor control board	CN32	Connector (Remote switch)	SW4 (I.B.)	Switch (model setting)
A.B.	Address board	CN41	Connector (HA terminal-A)	SWE (I.B.)	Connector (emergency operation)
TB2	Power supply terminal block	CN51	Connector (Centralized control)	SW1 (A.B.)	Switch (function setting)
TB5	Transmission terminal block	CN52	Connector (Remote display)	SW5 (A.B.)	Switch (function setting)
TB15	Transmission terminal block	CN90	Connector (Wireless)	SW7 (A.B.)	Switch (model setting)
FUSE	Fuse AC 250V 6.3A	TH21	Thermistor (inlet air)	SW11 (A.B.)	Switch (For setting the 1's digit in the address)
ZNR01, 02	Varistor	TH22	Thermistor (liquid pipe)	SW12 (A.B.)	Switch (For setting the 10's digit in the address)
DSA	Arrester	TH23	Thermistor (gas pipe)	SW14 (A.B.)	Switch (connection No.setting)
L1	AC reactor (Power factor improvement)	SW2 (I.B.)	Switch (capacity code setting)	SWA (A.B.)	Switch (static pressure setting)
CN27	Connector (Damper)	SW3 (I.B.)	Switch (function setting)	SWC (A.B.)	Switch (static pressure setting)
LEV	Electronic linear expan.valve				

- Note 1 Wiring to TB2, TB5, and TB15 indicated by the double-dashed lines is on-site work.
 2 ◎ terminal block, ⊖ connector.

Table.2 OPERATION OF LED FOR INDOOR CIRCUIT BOARD SERVICE

SYMBOL	LED operation under normal state
LED1	At applying main power source -> Lighting
LED2	At receiving MA transmission power source -> Lighting

[1] Refrigerant system diagram

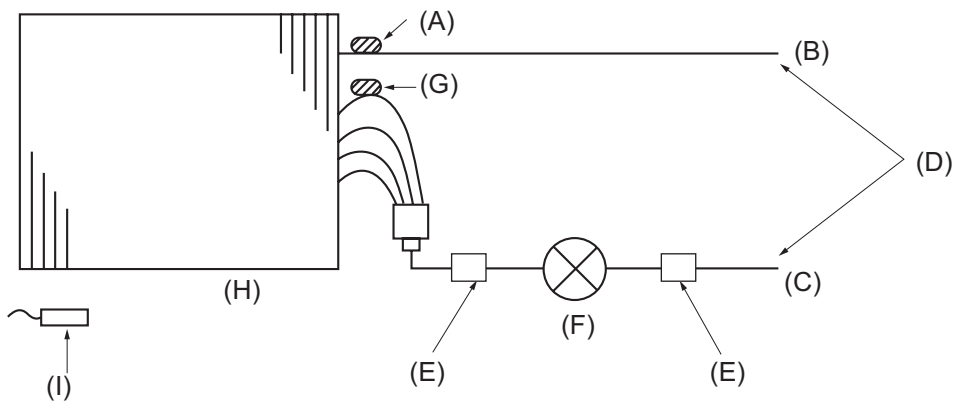

- (A) Gas pipe thermistor TH23
- (B) Gas pipe
- (C) Liquid pipe
- (D) Brazed connections
- (E) Strainer (#100 mesh)
- (F) Linear expansion valve
- (G) Liquid pipe thermistor TH22
- (H) Heat exchanger
- (I) Room temperature thermistor TH21

Capacity	PFFY-P20, 25, 32, 40, 50VLRMM-E	PFFY-P63VLRMM-E
Gas pipe	ø12.7 [1/2]	ø15.88 [5/8]
Liquid pipe	ø6.35 [1/4]	ø9.52 [3/8]

[1] Troubleshooting

1. Check methods

1. Component and check points

(1) Thermistor

- Room temperature thermistor (TH21)
- Liquid pipe thermistor (TH22)
- Gas pipe thermistor (TH23)

Disconnect the connector and measure the resistance between terminals with a tester.
(Ambient temperature 10°C - 30°C)

Normal	Abnormal
4.3kΩ - 9.6kΩ	Open or short

(Refer to the thermistor characteristic graph below.)

1) Thermistor characteristic graph

Low-temperature thermistor

- Room temperature thermistor (TH21)
- Liquid pipe thermistor (TH22)
- Gas pipe thermistor (TH23)

- Thermistor $R_0 = 15 \text{ k}\Omega \pm 3\%$
- Multiplier of B = $3480 \text{ k}\Omega \pm 2\%$

$$R_t = 15 \exp \left\{ 3480 \left(\frac{1}{273+t} - \frac{1}{273} \right) \right\}$$

- 0°C 15kΩ
- 10°C 9.6kΩ
- 20°C 6.3kΩ
- 25°C 5.2kΩ
- 30°C 4.3kΩ
- 40°C 3.0kΩ

(A) Temperature (°C)

(B) Resistance (kΩ)

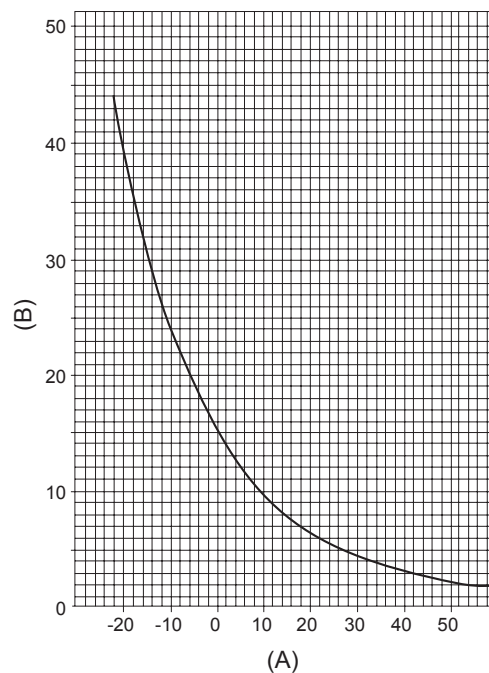

(2) Fan motor (CNMF)

Refer to the page on "DC fan motor (fan motor/indoor control board)."

(3) Linear expansion valve

Disconnect the connector, and measure the resistance between terminals with a tester.
Refer to the next page for details.

	Normal				Abnormal
		1-5 White-Red	2-6 Yellow-Brown	3-5 Orange-Red	4-6 Blue-Brown
	150 kΩ ± 10%				

- (A) Brown
- (B) Red
- (C) Blue
- (D) Orange
- (E) Yellow
- (F) White

1) Summary of linear expansion valve (LEV) operation

- The LEV is operated by a stepping motor, which operates by receiving a pulse signal from the indoor control board.
- The LEV position changes in response to the pulse signal.

Indoor control board and LEV connection

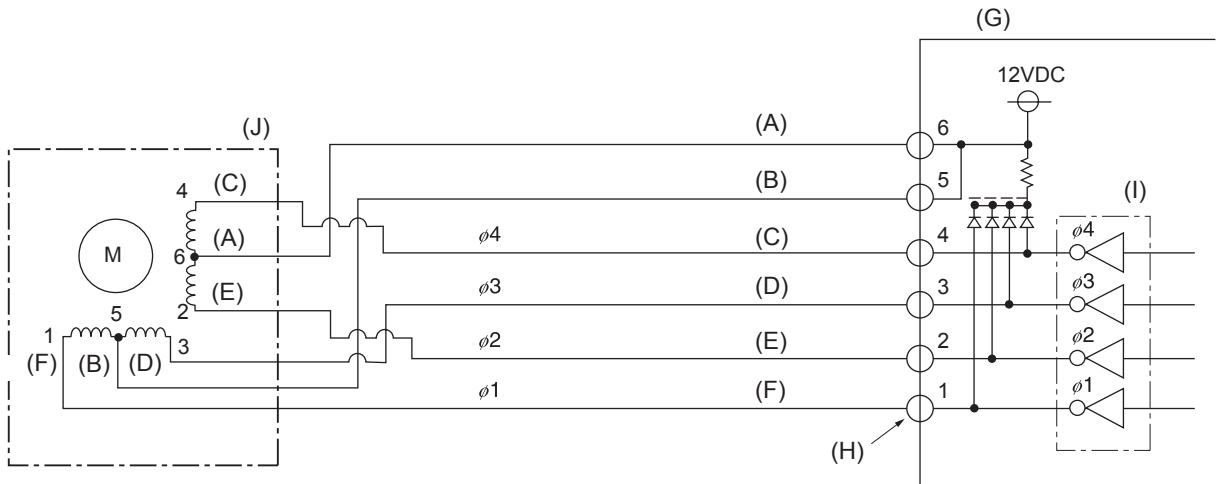

- | | |
|------------|----------------------------|
| (A) Brown | (F) White |
| (B) Red | (G) Control board |
| (C) Blue | (H) Connection (CN60) |
| (D) Orange | (I) Drive circuit |
| (E) Yellow | (J) Linear expansion valve |

Pulse signal output and valve operation

Phase number	Output pulse			
	1	2	3	4
ø1	ON	OFF	OFF	ON
ø2	ON	ON	OFF	OFF
ø3	OFF	ON	ON	OFF
ø4	OFF	OFF	ON	ON

The output pulse changes in the following order:

When the valve closes 1 -> 2 -> 3 -> 4 -> 1

When the valve opens 4 -> 3 -> 2 -> 1 -> 4

- When the valve position remains the same, all output signals will be OFF.
- If any output signal is missing or if the signal remains ON, the motor vibrates and makes clicking noise.

2) LEV operation

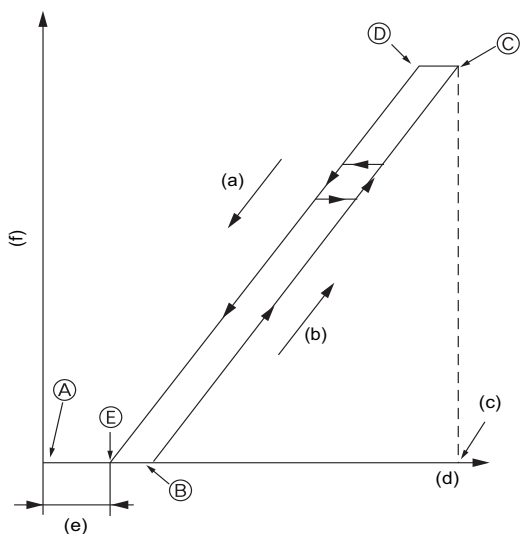

- (a) Close
- (b) Open
- (c) Fully open valve (2000 pulses)
- (d) No. of pulses
- (e) Extra tightning (0 - 200 pulse)
- (f) Valve opening degree

- When the power is turned on, a pulse signal of 2200 pulses is output (valve closure signal), to bring the valve to position A.
- When the valve is operating normally, it is free of vibration noise. If the valve locks or when it goes from point E to A in the figure, it makes louder noise than would be heard when there is an open phase.
- Check for abnormal sound/vibration by placing the metal tip of a screwdriver against the valve and the handle side against your ear.

3) Troubleshooting

Symptom	Checking Criteria	Remedy
Circuit failure on the microcomputer	Disconnect the connectors on the control board, and connect LEDs to test the circuit as shown below. <p>Pulse signals are output for 10 seconds when the main power is turned on. If there are LEDs that do not light up at all or remain lit after the pulses are turned off, there is a problem with the driving circuit.</p>	Replace the indoor control board if driving circuit failure is detected.
Locked LEV	The motor will idle and make small clicking noise if it is run while the LEV is locked. If this clicking noise is heard both when the valve is fully closed and while it is being opened, it indicates a problem.	Replace the LEV.
Disconnected or shorted LEV motor coils	Measure the resistance between the coils with a tester (red-white, red-orange, brown-yellow, brown-blue). The normal range of resistance is $150 \Omega \pm 10\%$	Replace the LEV.

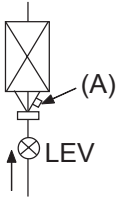
Symptom	Checking Criteria	Remedy
<p>Valve closure failure (leaky valve)</p>	<p>To check the LEV on the indoor unit, check the indoor unit liquid pipe temperature that appears on the operation monitor on the outdoor unit's multi control board while operating the indoor unit in question in the FAN mode and the other indoor units in the cooling mode.</p> <p>(A) Termistor (TH21)</p>  <p>Normally, the LEV is fully closed while the unit is in the FAN mode. If the valve is leaky, liquid pipe thermistor reading will be lower than normal. If it is significantly lower than the inlet temperature on the remote controller, valve closure failure is suspected. If the amount of leakage is insignificant, replacement of LEV is unnecessary unless it is causing a problem.</p>	<p>Replace the LEV if the amount of leakage is great.</p>
<p>Misconnections of connectors or contact failure</p>	<p>Perform a visual check for disconnected connectors. Perform a visual check of lead wire color.</p>	<p>Disconnect the connectors on the control board and perform a continuity test.</p>

2. DC fan motor (fan motor/indoor control board)

1. CAUTION

- A high voltage is applied to the connector for connection to the fan motor (CNMF).
- Do not unplug the connector CNMF with the unit energized to avoid damage to the indoor control board and fan motor.

2. Troubleshooting

- Symptom: Indoor unit fan does not run.

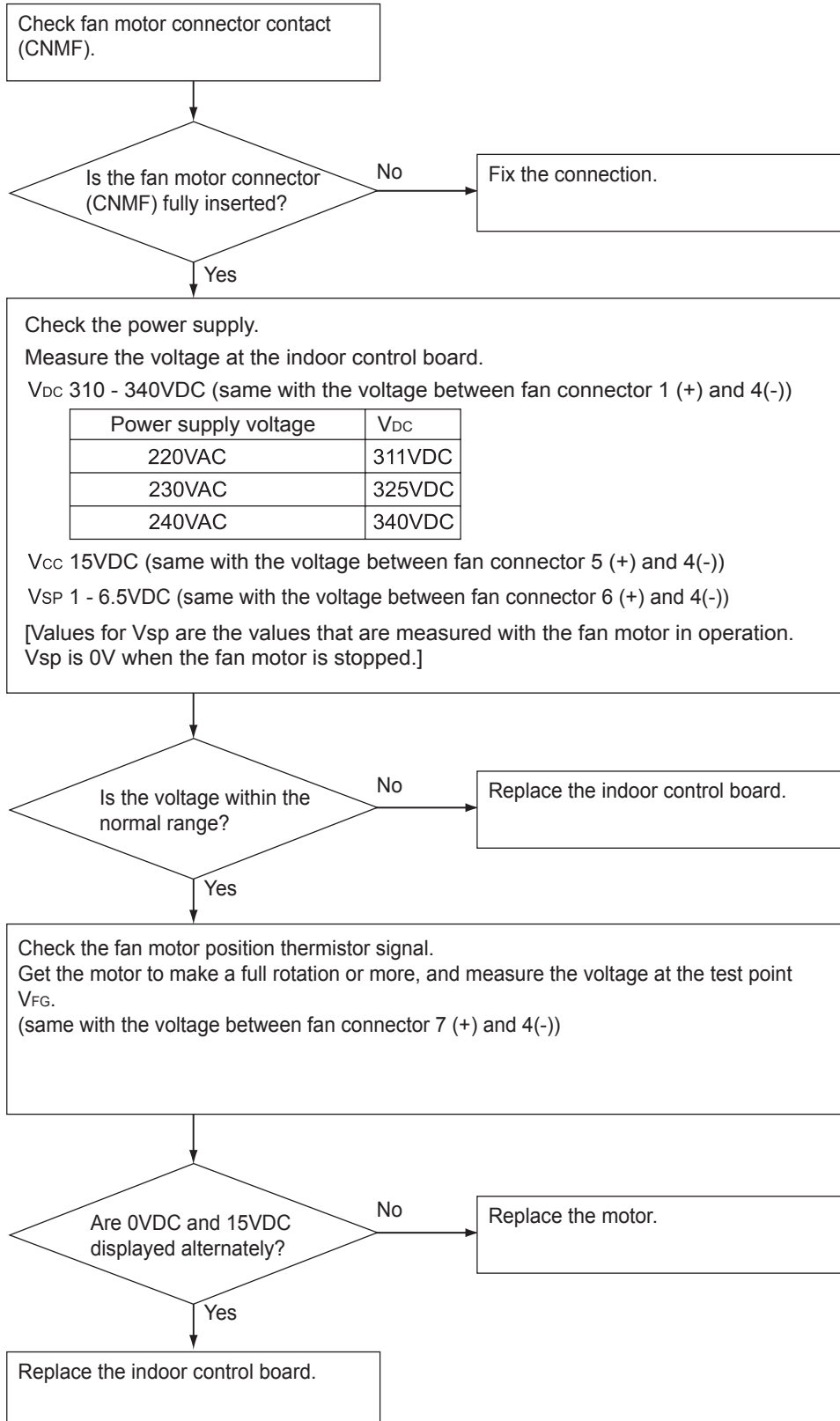

3. Address switch setting

Make sure that power to the unit is turned off.

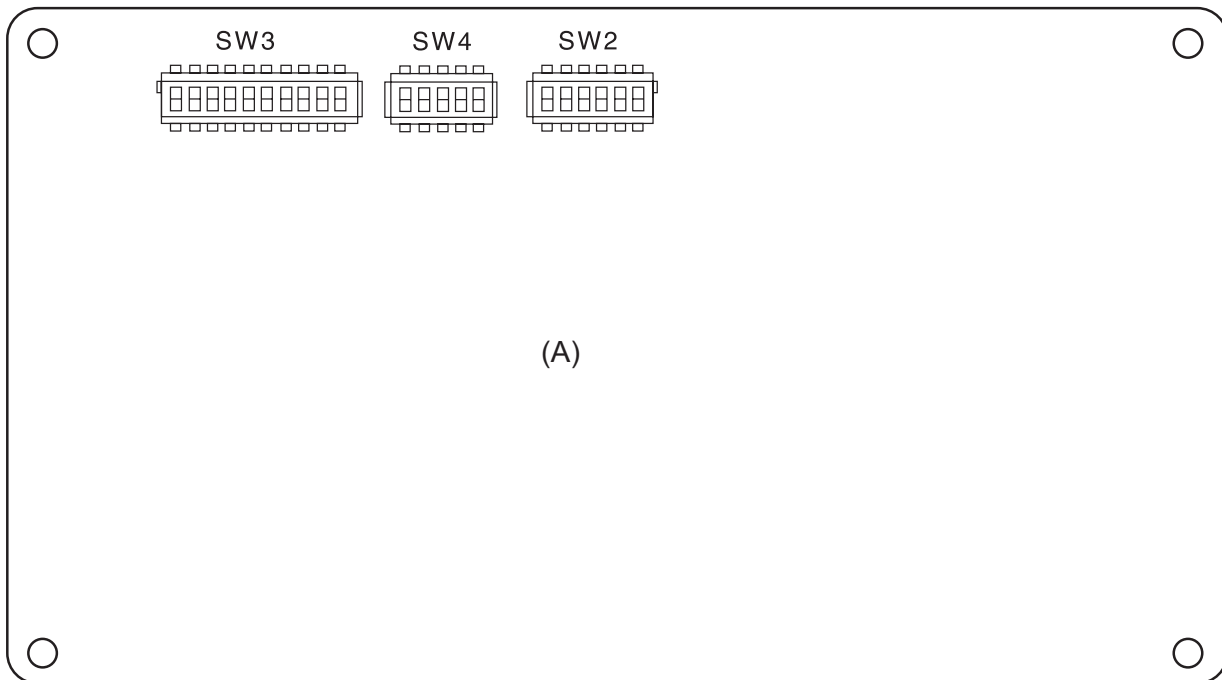

(A)

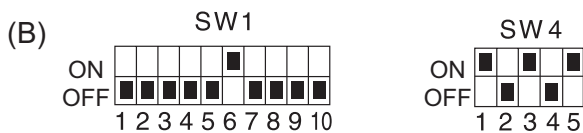

(B)

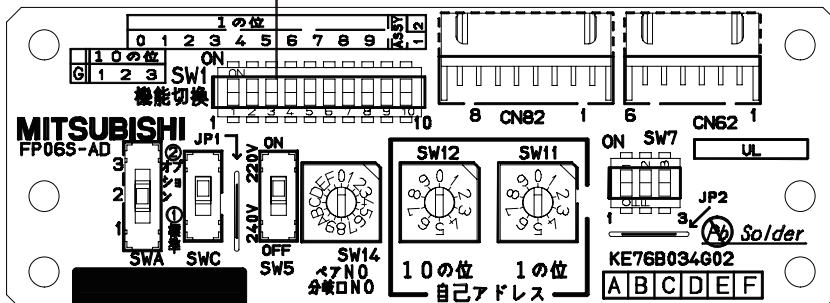

(A) Indoor unit control board

(B) Factory setting (all models)

1. When using an ME remote controller, set the address with the rotary switches (SW11, SW12).

•Address setting is not required when the unit remote controller is used.

On-site address setting is required for the indoor units to run.

2. Address settings vary in different systems.
Refer to the section on address setting in the outdoor unit installation manual.
3. Address is set with a combination of SW12 (10's digit) and SW11 (1's digit).
To set the address to "3," set SW12 to "0" and SW11 to "3."
To set the address to "25," set SW 12 to "2" and SW 11 to "5."

4. Voltage test points on the control board

1. PFFY-P20, 25, 32, 40, 50, 63VLRMM-E

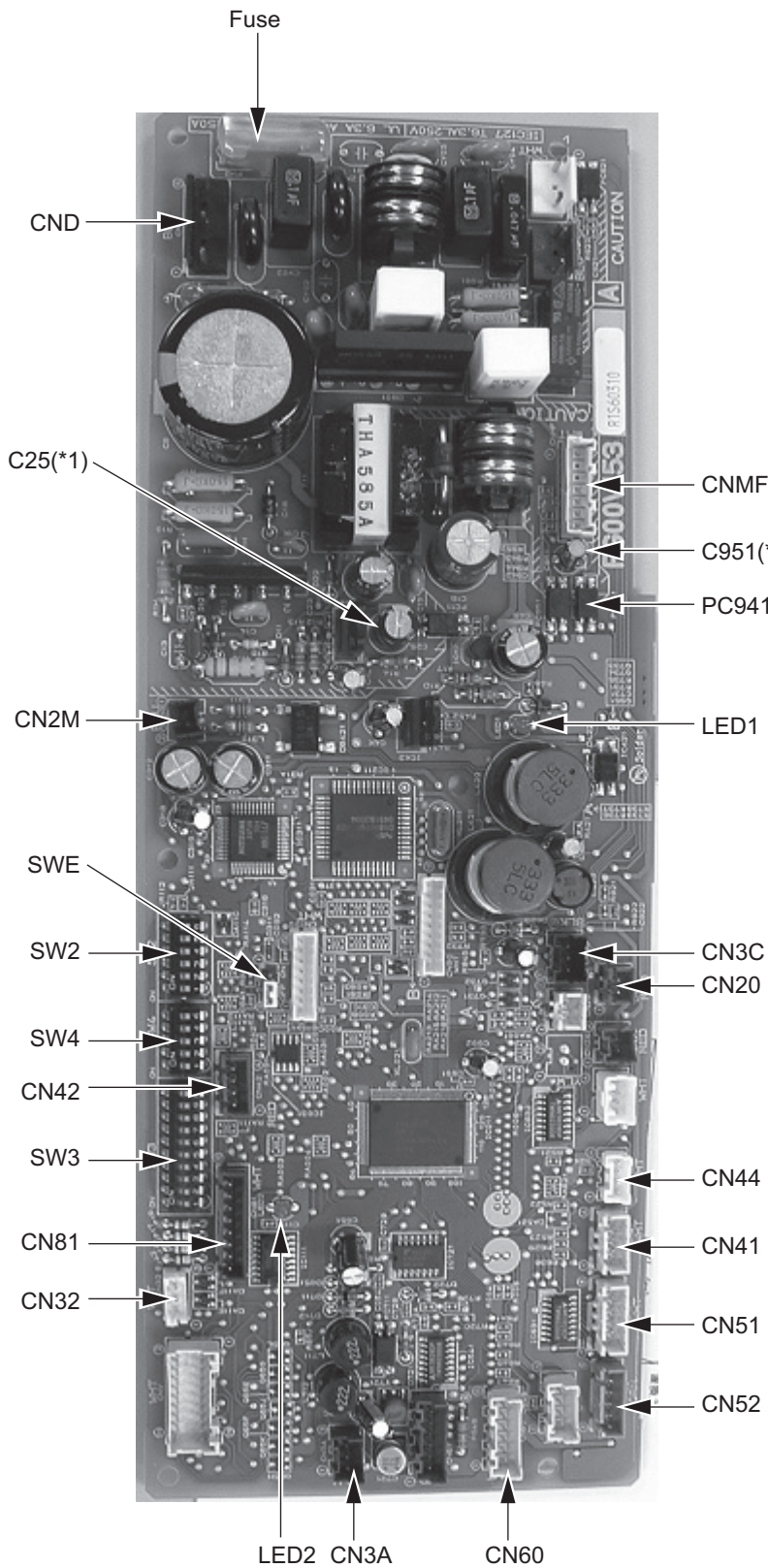

- Fuse Fuse(AC 250V 6.3A)
- CND Power supply voltage (220 - 240VAC)
- CN2M For M-NET transmission cable connection (24 - 30VDC)
- SWE Emergency operation
- SW2 Capacity setting
- SW4 Function setting
- CN42 For address board connection
- SW3 Function setting
- CN81 For address board connection
- CN32 Remote start/stop adapter
- CN3A For MA remote controller cable connection (10 - 13 VDC (Between 1 and 3.))
- CN52 Remote display
- CN51 Centralized control
- CN41 JAMA standard HA terminal A
- CN44 Thermistor (liquid/gas temperature)
- CN20 Thermistor (Inlet temperature)
- CN3C Indoor-outdoor transmission (0 - 24VDC)
- CNMF Fan motor output
 1 - 4: 310 - 340 VDC
 5 - 4: 15 VDC
 6 - 4: 0 - 6.5 VDC
 7 - 4: Stop 0 or 15 VDC
 Run 7.5 VDC
 (0 - 15 pulse)

- (*1)
- V_{FG} Voltage on the (-) side of PC941 and C25 (Same with the voltage between 7 (+) and 4 (-) of CNMF)
 - V_{CC} Voltage between the C25 pins 15 VDC (Same with the voltage between 5 (+) and 4 (-) of CNMF)
 - V_{sp} Voltage between the C951 pins 0VDC (with the fan stopped) 1 - 6.5VDC (with the fan in operation) (Same with the voltage between 6 (+) and 4 (-) of CNMF)

5. Dipswitch setting (Factory setting)

1. Function setting

(1) SW1

Switch position	Function	Switch setting	
		ON	OFF
1	Active Thermistor (Intake air thermistor)	Built-in thermistor on the remote controller	Indoor unit
2	Filter clogging detection	Available	Unavailable
3	Filter life	2500 hr	100 hr
4	Outdoor air intake	Enabled	Disabled
5	Remote display	Thermo-ON signal	Fan output
6	Humidifier operation	During heating mode	During heating operation
7	Fan speed	Low	Very low
8	Fan speed at heating Thermo-OFF	Preset fan speed	Follows the setting of SW1-7
9	Auto restart after power failure	Enabled	Disabled
10	Power start/stop	Enabled	Disabled

1) Address board

Factory setting



(2) SW3

Switch position	Function	Switch setting	
		ON	OFF
1	Unit type	Cooling only	Heat pump
2	-	-	-
3	-	-	-
4	-	-	-
5	-	-	-
6	-	-	-
7	-	-	-
8	Heating 4-deg up	Disabled	Enabled

1) Indoor control board

Dipswitch settings must be made while the unit is stopped.

Factory setting



2. Capacity code setting

(1) SW2

1) Indoor control board

Dipswitch settings must be made while the unit is stopped.

Factory setting

The switches are set to correspond to the unit capacity.

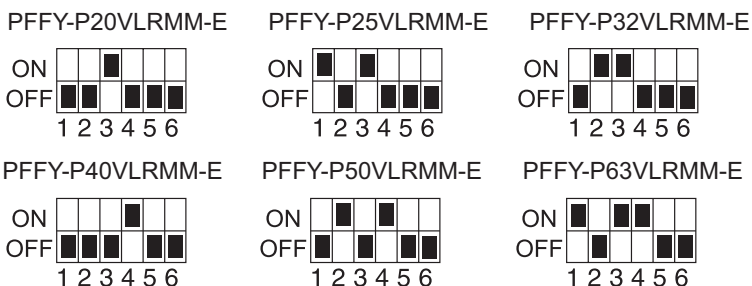

3. Model setting

(1) SW4

1) Indoor control board

Dipswitch settings must be made while the unit is stopped.

Factory setting









Note:

Changes made to the dipswitches SW1, SW2, and SW3 will become effective when the unit comes to a stop (remote controller off). There is no need to power cycle the unit.

4. External static pressure

(1) SWA, SWC

1) Address board

SWA, SWC		20Pa	40Pa	60Pa	Address board
External static pressure	1 - 3				
	1 - 2				
		SWA SWC	SWA SWC	SWA SWC	SWA SWC

Factory setting

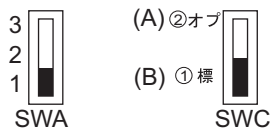

(A) Option

(B) Standard

Note:

Changes that are made to the dipswitches SWA and SWC immediately become effective regardless of the unit's operation status (RUN/STOP) or the remote controller status (ON/OFF).

5. 1's and 10's digits

(1) SW11, SW12 (Rotary switch)

The use of a network remote controller (PAR-F27MEA) requires address setting.

1) Address board

Address settings must be made while the unit is stopped.

Factory setting

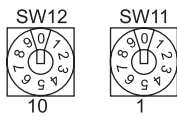

6. Connection No. setting

(1) SW14 (Rotary switch)

This switch is used when the unit connected to an R2 series of outdoor unit.

1) Address board

Factory setting



Note:

Changes to the dipswitches SW11, SW12 and SW14 must be made while the unit is stopped and the remote controller is OFF.

[1] Disassembly Procedure

1. Control box

Exercise caution when removing heavy parts.

1. Removing the control box cover
 - (1) Remove the fixing screws (two) on the cover (A) to remove it.

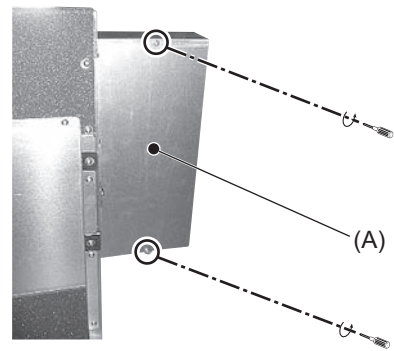

2. Thermistor (Intake air)

Exercise caution when removing heavy parts.

1. Removing the thermistor
 - (1) Pull out the thermistor holder (B) and thermistor (C) under the control box.

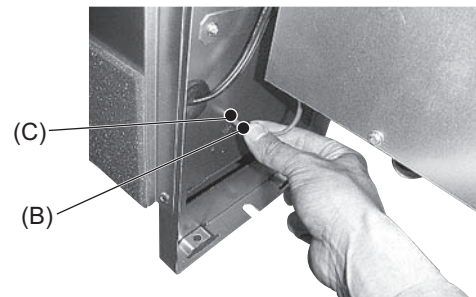

3. Drainpan

Exercise caution when removing heavy parts.

1. Removing the casing ass'y
 - (1) Remove the fixing screws(nine) of the plate(D) and remove the plate.

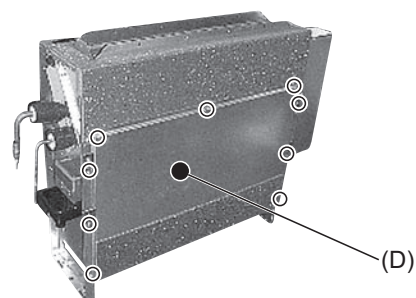

2. Remove the drainpan cover

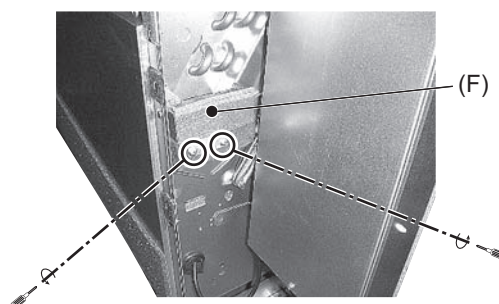
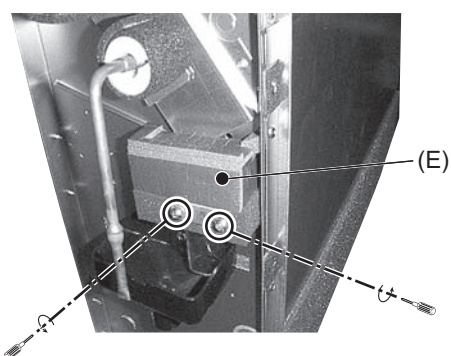

3. Remove the drainpan
 - (1) Remove the fixing screw of the both side frame.

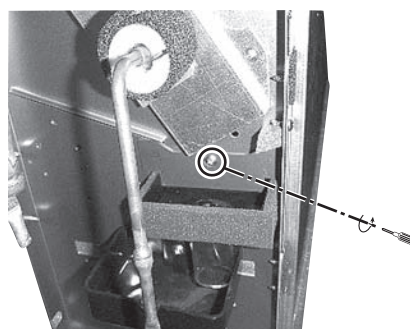

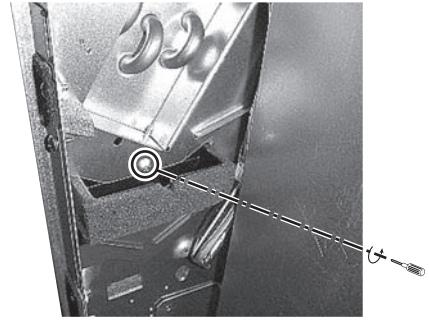

(2) Remove the magnet plate (G),(H),(I) of the both frame,remove the tube (J).

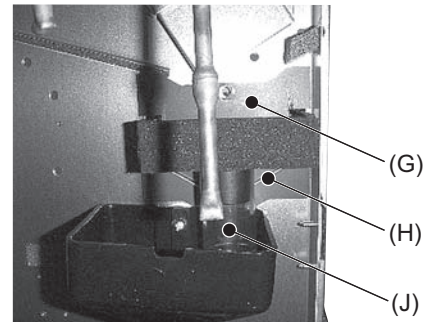

(3) Slide the drainpan in the direction of the arrow 1.

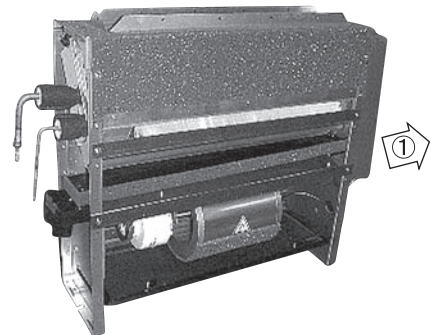

4. Thermistor (Gas pipe) (Liquid pipe)

Exercise caution when removing heavy parts.

1. Removing the thermistor

- (1) Remove the fixing screws (three), remove the cover (K) and (L).

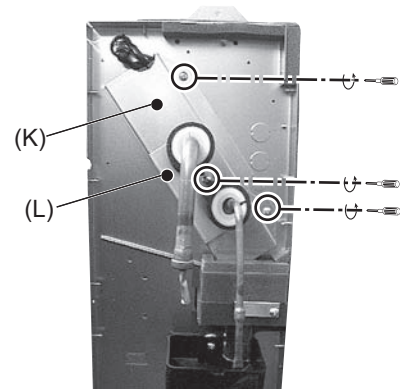

- (2) Remove the thermistor (gas)(M) and thermistor(liquid)(N).

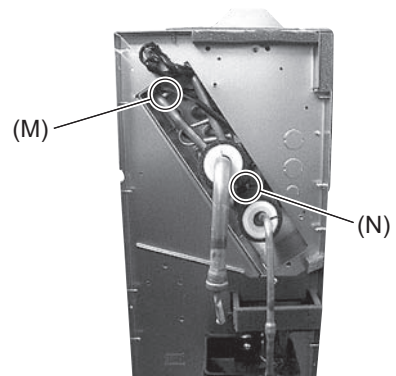

5. Fan and fan motor

Exercise caution when removing heavy parts.

1. Remove the plate(D) with procedure 3-1.
2. Remove the drainpan with procedure 3-2,3.
3. Sliding the fan section
 - (1) Remove the fixing screws(two).
 - (2) Slide the fan section in direction of the arrow 2.

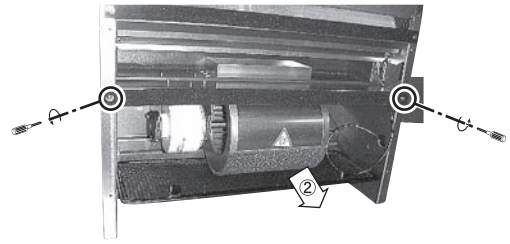

4. Removing the fan motor
 - (1) Remove the fixing screws(three)(a) on both sides of the fan casing(O) and turn the fan casing(O) in the upward direction (arrow 3).
 - (2) Remove the fan motor shaft fixing screw and remove the fan casing(O) and sirocco fan.
 - (3) Remove the fixing screws(two)(b) of the motor fixtures(two) and remove the motor.

Notice: In case of the Model(PFFY-P32 - 63VLRMM-E) stick out the motor shafts on both side of the motor.

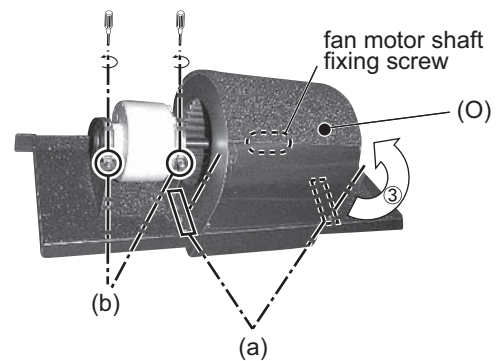

6. Heat exchanger

Exercise caution when removing heavy parts.

1. Remove the plate(D) with procedure 3-1.
2. Removing the air diffuser ass'y
 - (1) Remove the fixing screws(eight) of the air diffuser ass'y(P) and remove it.

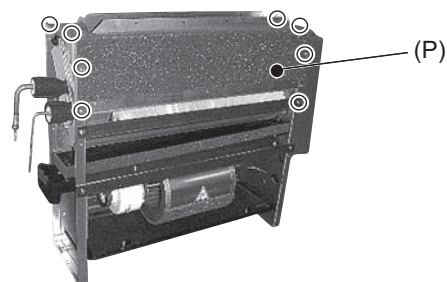

3. Remove the cover1,2 with procedure 4-1.
4. Removing the Heat exchanger
 - (1) Remove the fixing screws(four) and remove the heat exchanger support.

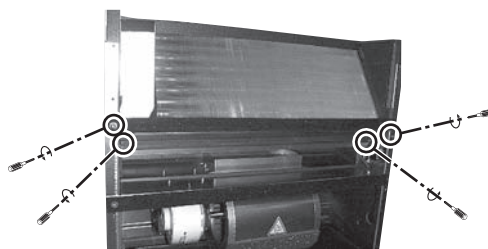

- (2) Remove the fixing screws(two) and remove the heat exchanger cover(Q).

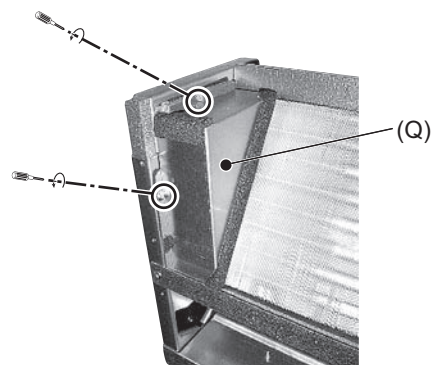

- (3) Remove the heat exchanger, moving from side to side.

