

Fresh Master

Models:

GUF-50RDH3 · GUF-50RD3

GUF-100RDH3 · GUF-100RD3

Installation Instructions

(For use by dealer/contractor)

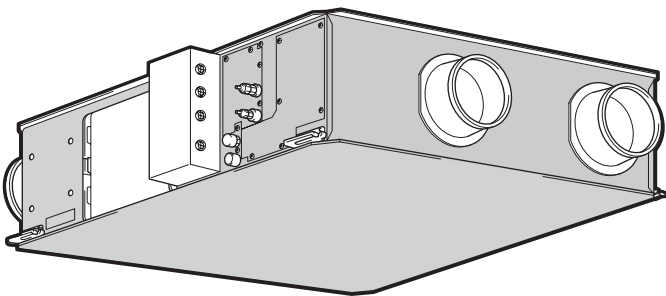

GUF-50RDH3 shown above.

Humidifier function not available on GUF-50RD3 and GUF-100RD3.

Contents

1. Safety precautions	2-4
2. Accessories	5
3. Outline drawings	5
4. Selecting an installation site	6
5. Installing the Fresh Master	6-7
6. Supply pipe and drain pipe work	8
7. Refrigerant pipe work	9-11
8. Electrical wiring	12-16
9. Feature settings	17-19
10. Test run	19-20
11. Troubleshooting	21

- Please take the time to read through these instructions before commencing with the installation work. They will help to install the Fresh Master properly and safely.
- The separate Operating Instructions are for the user. Make sure that they are handed over to the customer.

The warranty will not apply to damage resulting from failure to follow the warnings and precautions set forth in the Installation Instructions.

CITY MULTI

For use with the R410A&R407C&R22

1. Safety precautions

- ▶ Before operating the unit, make sure you read all the “Safety precautions”.
- ▶ “Safety precautions” lists important points about safety. Please be sure to follow them.

Symbols used in the text

Warning:

Describes precautions that should be observed to avoid the risk of injury or death to the user.

Caution:

Describes precautions that should be observed to prevent damage to the unit.

Symbols used in the illustrations

 : Indicates that important instructions must be followed.

 : Indicates a part which must be grounded.

 : Beware of electric shock. (This symbol is displayed on the main unit label.) <Colour: Yellow>

Warning:

Carefully read the labels affixed to the main unit.

1.1. Installation

- ▶ After you have read this manual, keep it and the Installation Manual in a safe place for easy reference whenever a question arises. If the unit is going to be operated by another person, make sure that this manual is given to him or her.

Warning:

- The unit should not be installed by the user. Ask the dealer or an authorized company to install the unit. If the unit is installed improperly, water leakage, electric shock or fire may result.
- Use only accessories authorized by Mitsubishi Electric and ask your dealer or an authorized company to install them. If accessories are installed improperly, water leakage, electric shock or fire may result.
- The Installation Manual details the suggested installation method. Any structural alteration necessary for installation must comply with local building code requirements.
- Never repair the unit or transfer it to another site by yourself. If repair is performed improperly, water leakage, electric shock or fire may result. If you need to have the unit repaired or moved, consult your dealer.

1) Outdoor unit

Warning:

- The outdoor unit must be installed on a stable, level surface, in a place where there is no accumulation of snow, leaves or rubbish.
- Do not stand on, or place any items on the unit. You may fall down or the item may fall, causing injury.

Caution:

The outdoor unit should be installed in a location where air and noise emitted by the unit will not disturb the neighbours.

2) Fresh Master

Warning:

The Fresh Master should be securely installed. If the unit is loosely mounted, it may fall, causing injury.

3) Remote controller

Warning:

The Remote controller should be installed in such a way that children cannot play with it.

4) Drain hose

Caution:

Make sure that the drain hose is installed so that drainage can go ahead smoothly. Incorrect installation may result in water leakage, causing damage to furniture.

5) Power Supply, fuse or circuit breaker

Warning:

- Make sure that the unit is powered by a dedicated power supply. Other appliances connected to the same power supply could cause an overload.
- Make sure that there is a mains power switch.
- Be sure to adhere to the unit's voltage and fuse circuit breaker ratings. Never use a cable or a fuse with a higher rating than the one specified.

6) Grounding

Caution:

- The unit must be properly grounded. Never connect the grounding wire to a gas pipe, water pipe, lightning conductor or telephone grounding wire. If the unit is not grounded properly, electric shock may result.
- Check frequently that the ground wire from the outdoor unit is properly connected to both the unit's ground terminal and the grounding electrode.

1.2. Precautions for devices that use R407C refrigerant

⚠ Caution:

- **Do not use the existing refrigerant piping.**
 - The old refrigerant and refrigerator oil in the existing piping contains a large amount of chlorine which may cause the refrigerator oil of the new unit to deteriorate.
- **Use refrigerant piping made of C1220 (CU-DHP) phosphorus deoxidized copper as specified in the JIS H3300 "Copper and copper alloy seamless pipes and tubes". In addition, be sure that the inner and outer surfaces of the pipes are clean and free of hazardous sulphur, oxides, dust/dirt, shaving particles, oils, moisture, or any other contaminant.**
 - Contaminants on the inside of the refrigerant piping may cause the refrigerant residual oil to deteriorate.
- **Store the piping to be used during installation indoors and keep both ends of the piping sealed until just before brazing. (Store elbows and other joints in a plastic bag.)**
 - If dust, dirt, or water enters the refrigerant cycle, deterioration of the oil and compressor trouble may result.
- **Use ester oil, ether oil or alkylbenzene (small amount) same as the refrigerator oil to coat flares and flange connections.**
 - The refrigerator oil will degrade if it is mixed with a large amount of mineral oil.
- **Use liquid refrigerant to fill the system.**
 - If gas refrigerant is used to seal the system, the composition of the refrigerant in the cylinder will change and performance may drop.
- **Do not use a refrigerant other than R407C.**
 - If another refrigerant (R22, etc.) is used, the chlorine in the refrigerant may cause the refrigerator oil to deteriorate.
- **Use a vacuum pump with a reverse flow check valve.**
 - The vacuum pump oil may flow back into the refrigerant cycle and cause the refrigerator oil to deteriorate.
- **Do not use the following tools that are used with conventional refrigerants.**

(Gauge manifold, charge hose, gas leak detector, reverse flow check valve, refrigerant charge base, vacuum gauge, refrigerant recovery equipment)

 - If the conventional refrigerant and refrigerator oil are mixed in the R407C, the refrigerant may deteriorate.
 - If water is mixed in the R407C, the refrigerator oil may deteriorate.
 - Since R407C does not contain any chlorine, gas leak detectors for conventional refrigerants will not react to it.
- **Do not use a charging cylinder.**
 - Using a charging cylinder may cause the refrigerant to deteriorate.
- **Be especially careful when managing the tools.**
 - If dust, dirt, or water gets in the refrigerant cycle, the refrigerant may deteriorate.

1.3. Precautions for devices that use R410A refrigerant

- **Make sure to use new refrigerant piping.**
 - When using the existing piping which used R22, take care of the following points.
 - Replace the flare nut with that is attached to the product. Flare section must be finished with the flare processing. (See P.10.)
 - Use of piping with thin wall should be avoided. (See P.10.)
- **Use refrigerant piping made of C1220 (CU-DHP) phosphorus deoxidized copper as specified in the JIS H3300 "Copper and copper alloy seamless pipes and tubes". The pipes must have the wall thickness as shown in the table below. In addition, be sure that the inner and outer surfaces of the pipes are clean and free of hazardous sulphur, oxides, dust/dirt, shaving particles, oils, moisture, or any other contaminant.**

ø6.35, Wall thickness 0.8 mm	ø9.52, Wall thickness 0.8 mm
ø12.7, Wall thickness 0.8 mm	ø15.88, Wall thickness 1.0 mm

It is strictly prohibited to use pipes with thin wall not listed in the above table.

If the inside of pipe is contaminated, it could cause deterioration of refrigerator oil, or other problems.

- **Store the piping to be used during installation indoors and keep both ends of the piping sealed until just before brazing. (Store elbows and other joints in a plastic bag.)**
 - If dust, dirt, or water enters the refrigerant cycle, deterioration of the oil and compressor trouble may result.
- **Use ester oil, ether oil or alkylbenzene (small amount) same as the refrigerator oil to coat flares and flange connections.**
 - The refrigerator oil will degrade if it is mixed with a large amount of mineral oil.
- **Do not use a refrigerant other than R410A.**
 - If another refrigerant (R22, etc.) is used, the chlorine in the refrigerant may cause the refrigerator oil to deteriorate.
- **Use a vacuum pump with a reverse flow check valve.**
 - The vacuum pump oil may flow back into the refrigerant cycle and cause the refrigerator oil to deteriorate.
- **For the following tools, use only the tools special to the refrigerant R410A.**
 - Tools as listed in the following table are required for the refrigerant R410A.

Tool name (For R410A)	
Gauge manifold	Flare tool
Charging hose	Protrusion adjust copper pipe gauge
Gas leak detector	Vacuum pump adaptor
Torque wrench	Balance for refrigerant charging

- **Be especially careful when managing the tools.**
 - If dust, dirt, or water gets in the refrigerant cycle, the refrigerant may deteriorate.
- **Do not use a charging cylinder.**
 - Using a charging cylinder may cause the refrigerant to deteriorate.

1.4. Before conducting supply pipe and drain pipe work

[Supply pipe work is not required for GUF-50 · 100RD3]

⚠ Caution:

- **The water quality of the permeable film humidifier's supply water should meet public waterworks standards, and have a hardness less than 100 mg/ℓ. If the supply water does not meet these standards, use a deionizer.**
- **The supply pressure must be within the range of 2×10⁴pa to 49×10⁴pa.**
 - Supply pressure that is lower than the specified range will cause the water to not supplied the permeable-film humidifier, and the humidifier may not work. Supply pressure that exceeds the specified range may cause damage to the solenoid valve and result in water leaks.
- **Drain pipe gradient must be more than 1/100.**
 - Drain water will not be properly discharged.
- **For areas that are extremely cold in winter, perform freeze-prevention on the supply pipe by wrapping a freeze prevention heater and thermal insulation.**
 - Cold temperatures may freeze water, and damage supply pipe.
- **Install the drain piping according to this installation Manual to ensure proper drainage. Wrap thermal insulation around the pipes to prevent condensation.**
 - Improper drain piping may cause water leakage and damage to furniture and other possessions.

1.5. Before getting installed

⚠ Caution:

- **Do not install the unit where combustible gas may leak.**
 - If the gas leaks and accumulates around the unit, an explosion may result.
- **Do not use the Fresh Master where food, pets, plants, precision instruments, or artwork are kept.**
 - The quality of the food, etc. may deteriorate.
- **Do not use the Fresh Master in special environments.**
 - Oil, steam, sulfuric smoke, etc. can significantly reduce the performance of the Fresh Master or damage its parts.
- **When installing the unit in a hospital, communication station, or similar place, provide sufficient protection against noise.**
 - The inverter equipment, private power generator, high-frequency medical equipment, or radio communication equipment may cause the Fresh Master to operate erroneously, or fail to operate. On the other hand, the Fresh Master may affect such equipment by creating noise that disturbs medical treatment or image broadcasting.
- **Do not install the unit on a structure that may cause leakage.**
 - When the room humidity exceeds 80% or when the drain pipe is clogged, condensation may drip from the Fresh Master. Perform collective drainage work together with the outdoor unit, as required.

1.6. Before getting installed (moved) - electrical work

⚠ Caution:

- **Ground the unit.**
 - Do not connect the ground wire to gas or water pipes, lightning rods, or telephone ground lines. Improper grounding may result in electric shock.
- **Install the power cable so that tension is not applied to the cable.**
 - Tension may cause the cable to break and generate heat and cause a fire.
- **Install an leak circuit breaker, as required.**
 - If an leak circuit breaker is not installed, electric shock may result.
- **Use power line cables of sufficient current carrying capacity and rating.**
 - Cables that are too small may leak, generate heat, and cause a fire.
- **Use only a circuit breaker and fuse of the specified capacity.**
 - A fuse or circuit breaker of a larger capacity or a steel or copper wire may result in a general unit failure or fire.
- **Do not wash the Fresh Master.**
 - Washing them may cause an electric shock.
- **Be careful that the installation base is not damaged by long use.**
 - If the damage is left uncorrected, the unit may fall and cause personal injury or property damage.
- **Be very careful about product transportation.**
 - Only one person should not carry the product if it weighs more than 20 kg.
 - Fresh Master use PP bands for packaging. Do not use any PP bands for a means of transportation. It is dangerous.
 - Do not touch the heat exchanger fins. Doing so may cut your fingers.
 - When transporting the outdoor unit, suspend it at the specified positions on the unit base. Also support the outdoor unit at four points so that it cannot slip sideways.
- **Safely dispose of the packing materials.**
 - Packing materials, such as nails and other metal or wooden parts, may cause stabs or other injuries.
 - Tear apart and throw away plastic packaging bags so that children can not play with them. If children play with a plastic bag which was not torn apart, they face the risk of suffocation.

1.7. Before starting the test run

⚠ Caution:

- **Turn on the power at least 12 hours before starting operation.**
 - Starting operation immediately after turning on the main power switch can result in severe damage to internal parts. Keep the power switch turned on during the operational season.
- **Do not touch the switches with wet fingers.**
 - Touching a switch with wet fingers can cause electrification.
- **Do not touch the refrigerant pipes during and immediately after operation.**
 - During and immediately after operation, the refrigerant pipes are may be hot or cold, depending on the condition of the refrigerant flowing through the refrigerant piping, compressor, and other refrigerant cycle parts. Your hands may suffer burns or frostbite if you touch the refrigerant pipes.
- **Do not operate the Fresh Master and outdoor unit with the panels and guards removed.**
 - Rotating, hot, or high-voltage parts can cause injuries.
- **Do not turn off the power immediately after stopping operation.**
 - Always wait at least five minutes before turning off the power. Otherwise, water leakage and trouble may occur.

2. Accessories

The unit is provided with the following accessories:

No.	Accessories	Qty
1	Pipe insulation	1
2	Flare insulation	1
3	Tie band	6
4	Duct connecting flanges	4
5	Mounting screws	16

3. Outline drawings

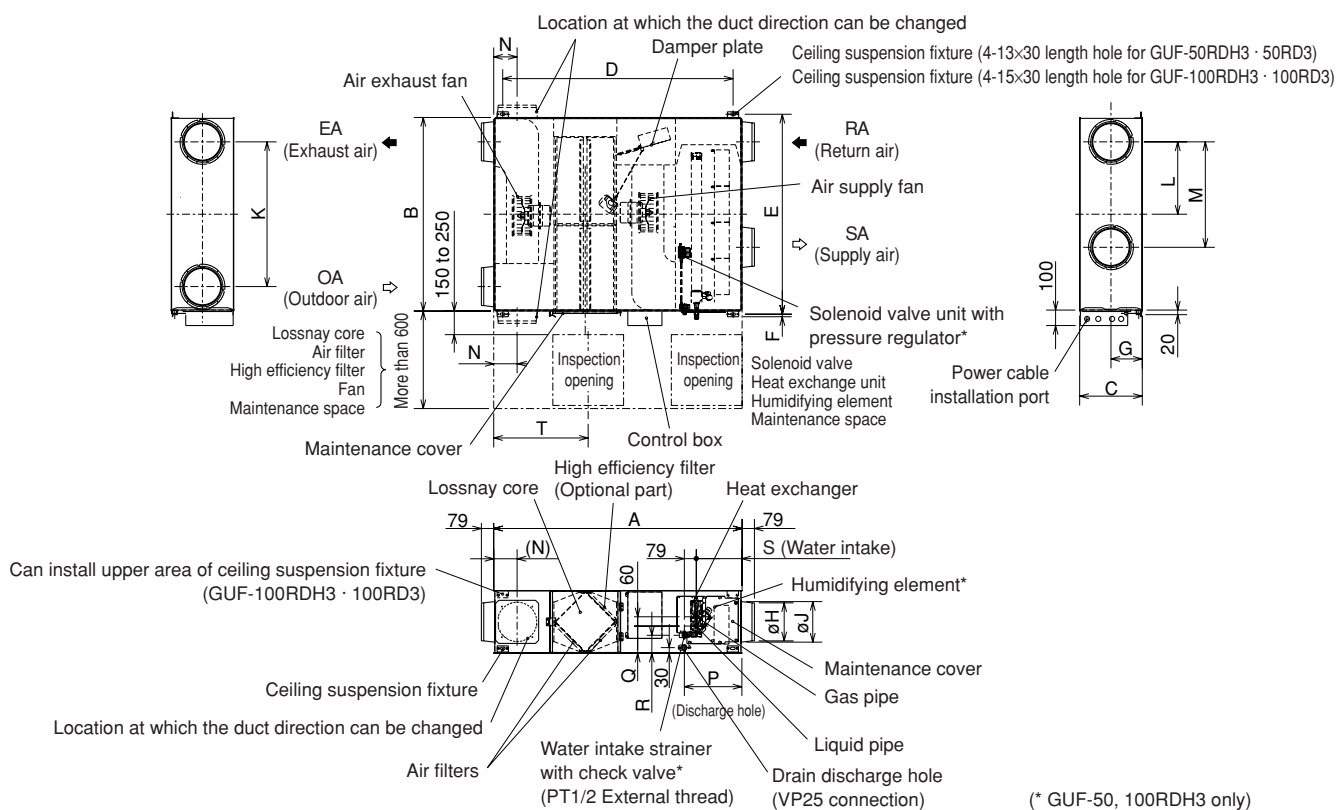

Unit (mm)

Model	External dimension			Ceiling suspension fixture pitch			Duct connection flange			Duct pitch				Humidification				Inspection opening	Weight (kg)	
	A	B	C	D	E	F	Nominal diameter	G	H	J	K	L	M	N	P	Q	R			S
GUF-50RDH3, GUF-50RD3	1288	1016	317	1185	1048	22	200	158.5	192	208	745	372.5	435	124	347	135	99	266	450	57 (54)
GUF-100RDH3, GUF-100RD3	1580	1231	398	1465	1271	16	250	199	242	258	920	460	670	149	361	169	110	280	600	98 (92)

*Values shown in parentheses “()” are for RD3.

4. Selecting an installation site

- Select a site with sturdy fixed surface sufficiently durable against the weight of unit.
- Before installing unit, the route to carry the unit to the installation site should be determined.
- Select a site where the unit is not affected by entering air.
- Select a site where the flow of supply, return, exhaust and outdoor air is not blocked.
- Select a site where refrigerant piping and exhaust/outdoor ducts can easily be led to the outside.
- Select a site which allows the supply air to be distributed fully in room.
- Select a location where the inspection opening can be installed.
- Do not install unit at a site with oil splashing or steam in large quantities.
- Do not install unit at a site where combustible gas may generate, flow in, stagnate or leak.
- Do not install unit at a site where equipment generating high frequency waves (a high frequency wave welder for example) is provided.
- Do not install unit at a site where fire detector is located at the supply air side. (Fire detector may operate erroneously due to the heated air supplied during heating operation.)
- When special chemical product may be scatter all around such as site chemical plants and hospitals, full investigation is required before installing unit. (The plastic components may be damaged depending on the chemical product applied.)
- Do not install this product in a refrigerated warehouse, heated swimming pool or other location where the temperature and humidity are significantly different.
(Failure to heed this warning may result in electrical shock or malfunction.)
- The electro-magnetic susceptibility has been chosen at a level that gains proper operation in residential areas, on business and light industrial premises and on small-scale enterprises, inside as well as outside of the buildings. All places of operation are characterised by their connection to the public low voltage power supply system.

4.1. Install the Fresh Master on a ceiling strong enough to sustain its weight

⚠ Warning:

The unit must be securely installed on a structure that can sustain its weight. If the unit is mounted on an unstable structure, it may fall down causing injuries.

4.2. Securing installation and service space

- Select the optimum direction of supply airflow according to the configuration of the room and the installation position.
- As the piping and wiring are connected at the side surfaces, and the maintenance is made at the same surfaces, allow a proper space properly. For the efficient suspension work and safety, provide a space as much as possible.

4.3. Standard installation examples

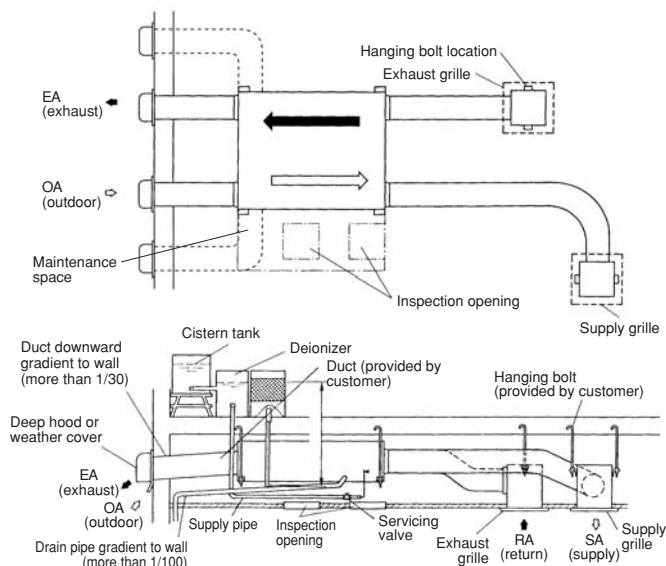

5. Installing the Fresh Master

5.1. Fixing hanging bolts

(Use M10 or M12 hanging bolts. The bolts and washers should be supplied in the field.)

(Give site of suspension strong structure.)

Hanging structure

- Ceiling: The ceiling structure varies from one building to another. For detailed information, consult your construction company.
- ① Reinforcing the ceiling with additional members (edge beam, etc.) must be required to keep the ceiling at level and to prevent the ceiling from vibrations.
 - ② Cut and remove the ceiling members.
 - ③ Reinforce the ceiling members, and add other members for fixing the ceiling boards.

- Mount the washers (outer diameter of >21 mm for M10, >24 mm for M12) and nuts obtained from a field supply onto the pre-recessed hanging bolts (M10 or M12) also obtained from a field supply, as shown in the figure.

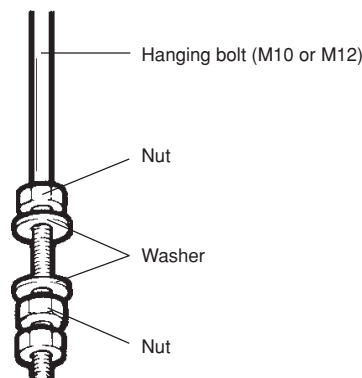

5.2. Attaching the duct connecting flanges

Use the screws supplied to secure the duct connecting flanges to the Fresh Master.

⚠ Caution:

- Before attaching the duct connecting flanges, check that no foreign matter (scraps of paper, vinyl, etc.) has found its way inside the main unit.
- Replace the screws that were removed when the duct connecting flange was removed back in place and securely tighten them.

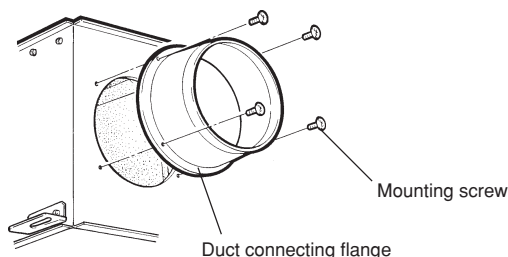

5.3. Hanging the unit body

1. Hang the ceiling suspension fixtures on the hanging bolts and adjust in such a way that the main unit is level.
2. Tighten up securely using double nuts in order to prevent looseness.

⚠ Caution:

- When suspending the main unit from the ceiling, do not handle it in such a way that force will be applied to the control box.
- Fasten the body so that it is oriented horizontally. (within 1°)

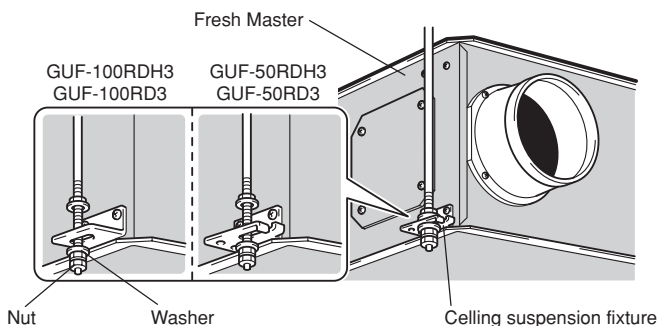

5.4. When changing the direction of the out door side duct (EA/OA)

Remove the flange cover and suspension fixture.

1. Remove the four mounting screws for the flange cover and remove the flange cover.
2. Remove the screws at the top mounting position.
3. Remove the ceiling suspension fixtures and attach them at higher mounting positions.
4. Tighten up the screws in the screw hole where the ceiling suspension fixtures were removed in order to prevent air leaks.

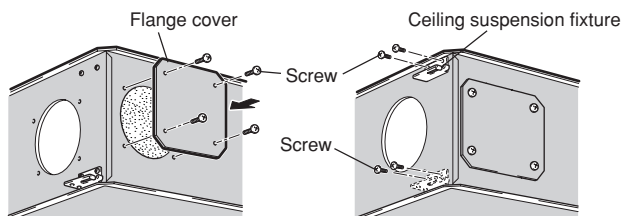

Mounting the duct connection flange

1. Use the mounting screws provided to mount the duct connection flange to the main body.
2. Use the four mounting screws that were removed to attach the flange cover.

5.5. Connecting the ducts

1. Fit the ducts securely into the duct connecting flanges, and wind aluminium tape available from a field supply around them to prevent air leaks.
2. Suspend the ducts from the ceiling so that their weight will not be applied to the Fresh Master.
3. The exhaust/outdoor and supply ducts must be covered with heat-insulating material in order to prevent condensation from forming.

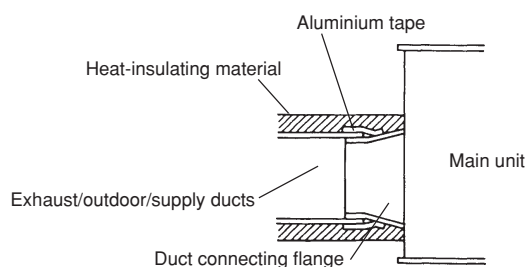
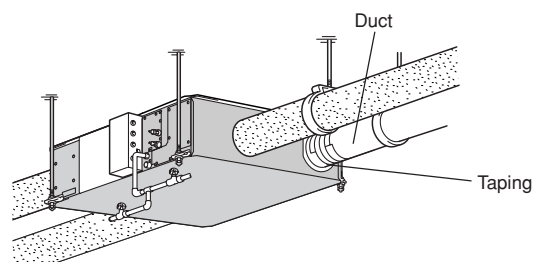

⚠ Caution:

- The main unit is equipped with connection locations for equipotential connection of ducts.
- Down ward gradient of outdoor duct: 1/30 or more (toward wall side)
- Provision of distance for the exhaust/outdoor ducts in table below (to prevent rain water from seeping in)

Model	Distance
GUF-50RDH3, GUF-50RD3	1 m or more
GUF-100RDH3, GUF-100RD3	2.5 m or more

- Before connecting the ducts, check that no sawdust or any other foreign matter (scraps of paper, vinyl, etc.) has found its way inside the ducts.
- Do not touch the damper plate inside the main unit when connecting the ducts.
- Do not install the ducts in the ways illustrated below. Doing so will reduce the air volume and give rise to abnormal sounds.

• Extremely sharp bends

• Bends right next to the outlet

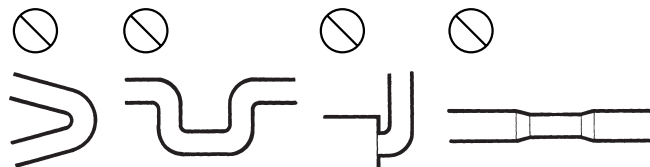

• Multiple bends

• Extreme reduction in the diameter of the connected ducts

6. Supply pipe and drain pipe work

Supply pipe work is not required for GUF-50 · 100RD3. Only perform the drain pipe work.

6.1. Supply pipe work

1. Connect a commercially available interlocked flexible metal hose or the equivalent between the water supply pipe and the water filler hole when performing pipe work for the water supply.
 - Set the water pressure between $2 \times 10^4 \text{ Pa}$ to $49 \times 10^4 \text{ Pa}$.
 - Install the servicing valve near the strainer then install the supply pipe.

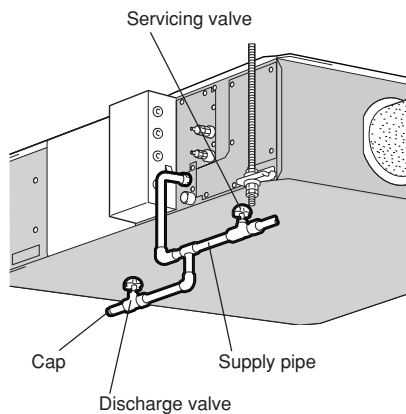

⚠ Caution:

- The supply water should meet public waterworks standards, and have a hardness less than 100 mg/l , otherwise the humidifier will clog up.
- Install the discharge and servicing valve in locations accessible from the inspection opening.
- Securely lock the supply pipe so that no force is applied to the strainer.
- When performing the supply pipe work, wash the pipe with fresh water prior to installation to prevent saw dust, etc. from entering, or install a discharge valve in the piping and sufficiently conduct water discharge before using until the water is clear.
- Take caution as to not let cutting oil or detergent from entering.
- The supply and drain pipes must be installed as such that they do not rest on the Maintenance cover and cover (humidifier).
- The supply and drain pipes must be properly installed so that there is no water leak.
- To prevent freezing when not using the unit for long periods of time, close the servicing valve, open the discharge valve, and remove the servicing valve and any water in the unit's supply water entrance. After removing the servicing valve and water, close the discharge valve.

2. Freeze-prevention work for extremely cold areas
Perform freeze prevention by wrapping a freeze-prevention heater (field supply) on the supply pipe.

- Wrap a freeze-prevention heater all the way to the Fresh Master.
- Insulation work must be performed upon the heater as well.

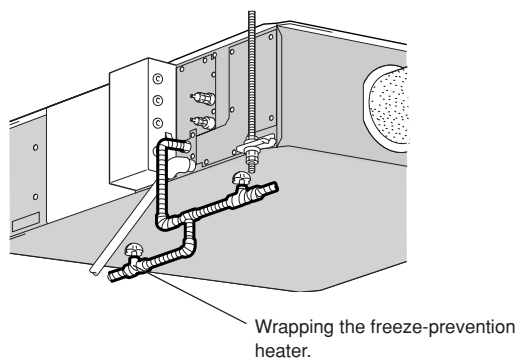

6.2. Drain pipe work

1. Connect a vinyl chloride VP25 elbow to the drain discharge port.
2. The drain pipe must be properly insulated from the drain discharge port.

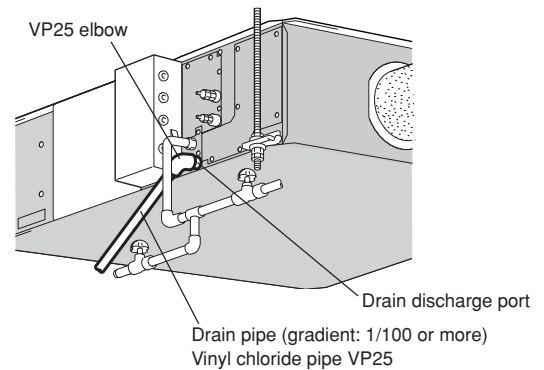

⚠ Caution:

- The pipe must be installed with gradient of more than 1/100.
- The drain pipe must be installed so that water does not accumulate inside.
- Check to make sure that the end of the drain pipe is at a location where discharge is possible and that the pipe can be properly drained.
- Do not install the drain pipe as shown below. (This will result in insufficient drainage)
- Do not insert the tip of the drain pipe into a gutter or the like. Doing so will cause the gutter to freeze in the event of heavy snowfall, resulting in water leakage from the main unit.

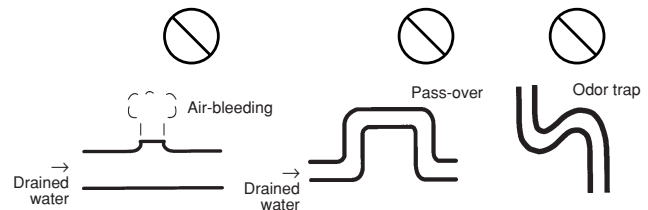

3. Make sure the pipe drains water properly.
 - (1) Remove the maintenance cover (for humidifying).
 - Remove the seven mounting screws, slide the maintenance cover to the right, and remove it from the potbelly-shaped holes (six locations for Model 50).
 - (2) Pull out the inner lid.
 - (3) Pour approximately 1,000 cc of water onto the drain tray.
 - (4) Confirm that the drain pipe drains away water at the pipe's final exit.
 - (5) Replace the inner lid and the maintenance cover (for humidifying).

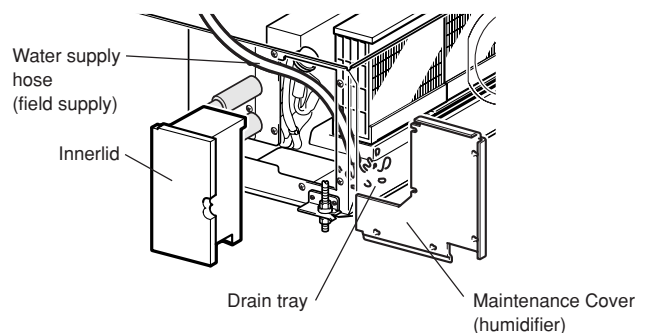

* The diagram shows GUF-50 · 100RDH3

7. Refrigerant pipe work

7.1. Refrigerant pipe specifications

To avoid dew drops, provide sufficient insulation to the refrigerant and drain pipes.

When using commercially available refrigerant pipes, be sure to use commercially available insulation (with a heat-resisting temperature of more than 100°C and thickness given below) onto both liquid and gas pipes.

Be also sure to use commercially available insulating material (with a formed polyethylene's specific gravity of 0.03 and thickness given below) onto all pipes which pass through rooms.

- ① Select the thickness of insulating material by pipe size.

Pipe size	Insulating material's thickness
6.4 mm to 25.4 mm	More than 12 mm
28.6 mm to 38.1 mm	More than 15 mm

- ② If the unit is used on the highest story of a building and under conditions of high temperature and humidity, it is necessary to use pipe size and insulating material's thickness more than those given in the table above.

- ③ If there are customer's specifications, simply follow them.

- ④ Refrigerant pipe specifications

Item		Model	GUF-50RDH3	GUF-100RDH3
			GUF-50RD3	GUF-100RD3
Refrigerant pipe (Flare connection)	Liquid pipe		ø6.35	ø9.52
	Gas pipe		ø12.7	ø15.88

- ⑤ Torque specifications

Outer dia of copper pipe	Tightening torque
ø6.35	14 ~ 18 N·m
ø9.52	34 ~ 42 N·m
ø12.7	49 ~ 61 N·m
ø15.88	68 ~ 82 N·m

- ⑥ Refrigerant system diagram

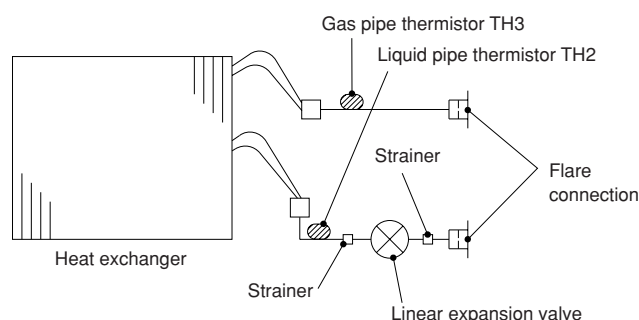

7.2. Refrigerant piping work

This piping work must be done in accordance with the installation manuals for both outdoor unit and BC controller (simultaneous cooling and heating series R2).

- With R2 systems connect Fresh Masters to BC controllers.
- For constraints on pipe length and allowable difference of elevation, refer to the outdoor unit manual.
- The method of pipe connection is flare connection.

Cautions On Refrigerant Piping

- ▶ Be sure to use non-oxidative brazing for brazing to ensure that no foreign matter or moisture enter into the pipe.
- ▶ Be sure to apply refrigerating machine oil over the flare connection seating surface and tighten the connection using a double spanner.
- ▶ Provide a metal brace to support the refrigerant pipe so that no load is imparted to the Fresh Master end pipe. This metal brace should be provided 50 cm away from the Fresh Master's flare connection.

⚠ Warning:

When installing and moving the unit, do not charge it with refrigerant other than the refrigerant (R410A R407C or R22) specified on the unit.

- Mixing of a different refrigerant, air, etc. may cause the refrigerant cycle to malfunction and result in severe damage.

⚠ Caution:

- Use refrigerant piping made of C1220 (CU-DHP) phosphorus deoxidized copper as specified in the JIS H3300 "Copper and copper alloy seamless pipes and tubes". In addition, be sure that the inner and outer surfaces of the pipes are clean and free of hazardous sulphur, oxides, dust/dirt, shaving particles, oils, moisture, or any other contaminant.
- Never use existing refrigerant piping.
 - The large amount of chlorine in conventional refrigerant and refrigerator oil in the existing piping will cause the new refrigerant to deteriorate.
- Store the piping to be used during installation indoors and keep both ends of the piping sealed until just before brazing.
 - If dust, dirt, or water gets into the refrigerant cycle, the oil will deteriorate and the compressor may fail.
- Use Suniso 4GS or 3GS (small amount) refrigerator oil to coat the flare and flange connection part. (For using R22)
- Use ester oil, ether oil or alkylbenzene (small amount) as the refrigerator oil to coat flares and flange connections. (For using R407C, R410A)
 - The refrigerant used in the unit is highly hygroscopic and mixes with water and will degrade the refrigerator oil.

- **Make sure to use new refrigerant piping.**
 - When using the existing piping which used R22, take care of the following points.
 - Replace the flare nut with that is attached to the product. Flare section must be finished with the flare processing.
 - Use of piping with thin wall should be avoided.

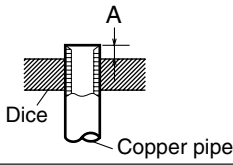

Pipe Dia. (mm)	Dimension A (mm)		
	R410A Flare Tool	When using conventional flare tool (R22/R407C)	
	Rigid (clutch type)		Imperial (wing nut) type
ø6.35 (1/4")	0~0.5	1.0~1.5	1.5~2.0
ø9.52 (3/8")	0~0.5	1.0~1.5	1.5~2.0
ø12.7 (1/2")	0~0.5	1.0~1.5	1.5~2.5
ø15.88 (5/8")	0~0.5	1.0~1.5	1.5~2.5

* When applying the flare processing for the refrigerant R410A using conventional tools, conduct the work referring to the above. If you use the copper pipe gauge for the adjustment of protrusion margin, you can secure the dimension A.

Coat small amount of ester oil, ether oil or hard alkylbenzen oil over the entire periphery of flare seat surface.

* Do not coat at the threaded section.
(Otherwise, you cannot lock the flare nut securely.)

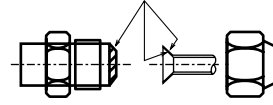

* Make sure to use only the flare nut attached to the main unit. (Off-the-shelf product could be cracked.)

Copper Pipe O.D.	Flare Dimension Dimension øB (mm)	
ø6.35	8.7~9.1	
ø9.52	12.8~13.2	
ø12.7	16.2~16.6	
ø15.88	19.3~19.7	

7.3. Request for refrigerant piping connection

Description of parts to be used

No.	Work procedures	Detail of work	Item to be observed	Reference drawing
1	Mount the provided pipe insulation (1) on the liquid pipe of the refrigerant piping, and then mount the flare insulation (2) on the gas pipe.	"IN" and "OUT" are marked on the inside of the flare insulation. Mount the portion marked "IN" near the unit body and the portion marked "OUT" on the field piping side.	<ul style="list-style-type: none"> Using the flare insulation of a different type may result in condensation forming. Check the type name on the insulation and be sure to use the correct one. To prevent a gap from forming near the unit's side plate, be sure that the flare insulation firmly contacts the unit's side plate before mounting. Incorrectly mounting the "INNER" and "OUTER" sides of the insulation may result in condensation forming. 	<p>Fig-1</p> <p>Fig-2 (Note *2)</p> <p>Fig-2</p>
2	Fixing of insulated pipe	<ul style="list-style-type: none"> Fasten the insulated pipe with the insulation tape. Firmly secure the insulation with the provided tie band (4) at the position indicated on the drawing. 	Seal the slit securely so that there are no openings. Be sure to mount the insulation so that the slit is on the top.	Fig-3 (Note *3)
3	Fixing of flare insulation	<ul style="list-style-type: none"> Fasten the flare insulation with the provided tape (3). Fasten with the provided tie band (4) at the position indicated on the drawing. 	Seal the slit securely so that there are no openings. Be sure to mount the insulation so that the slit is on the top.	Fig-3 (Note *4)

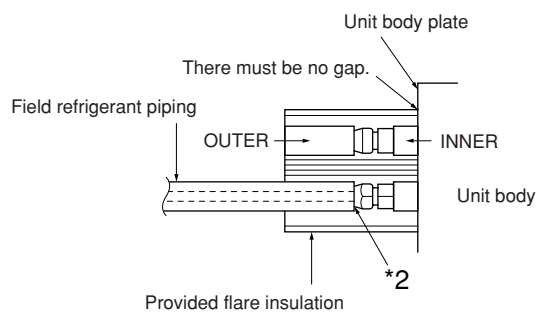
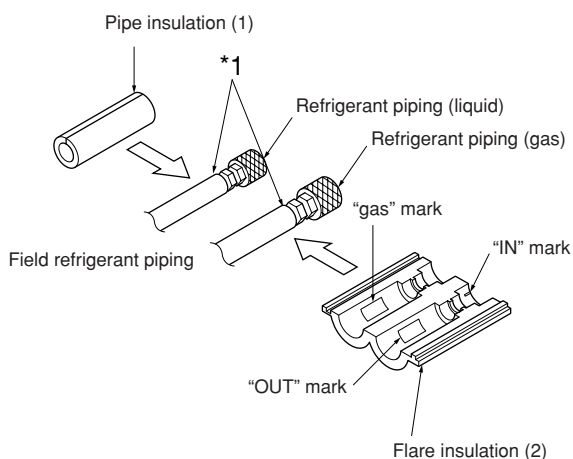

Fig-2 (figure showing the flare insulation)

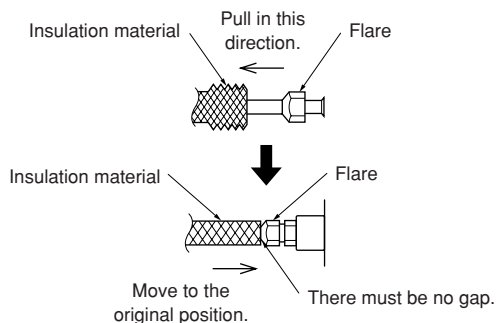

Fig-1

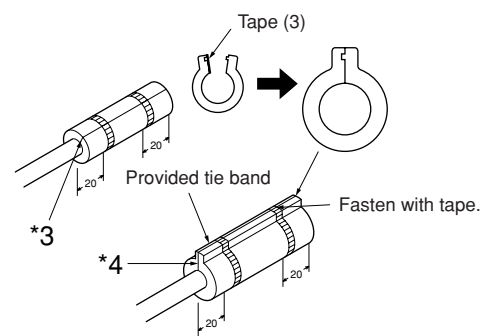

Fig-3

Notes:

- *1 Insert the flare nut into the field refrigerant piping. Pull the insulation material back at the area where it will be flared, then return it to its original position after performing the flare work.
Exposing copper piping may result in condensation forming. Be extremely careful when performing this operation.
- *2 There must be no gap.
- *3, *4 There must be no gap. Slit should be on the top.

8. Electrical wiring

8.1. Precautions on electrical wiring

⚠ Warning:

Electrical work should be done by qualified electrical engineers in accordance with “Engineering Standards For Electrical Installation” and supplied installation manuals. Special circuits should also be used. If the power circuit lacks capacity or has an installation failure, it may cause a risk of electric shock or fire.

1. Be sure to take power from the special branch circuit.
2. Be sure to install an earth leakage breaker to the power.
3. Install the unit to prevent that any of the control circuit cables (Remote controller, transmission cables) is brought in direct contact with the power cable outside the unit.
4. Ensure that there is no slack on all wire connections.

5. Some cables (power, Remote controller, transmission cables) above the ceiling may be bitten by mice. Use as many metal pipes as possible to insert the cables into them for protection.
6. Never connect the power supply cable to leads for the transmission cables. Otherwise the electronic circuit would be broken.
7. Be sure to connect control cables to the Fresh Master, Remote controller, and the outdoor unit.
8. Put the unit to the ground on the outdoor unit side.
9. Select control cables from the conditions given below.

⚠ Caution:

Be sure to put the unit to the ground on the outdoor unit side. Do not connect the earth cable to any gas pipe, water pipe, lightning rod, or telephone earth cable. Incomplete grounding may cause a risk of electric shock.

8.2. Types of control cables

1. Wiring M-NET transmission cables

- Types of transmission cables
Design wiring in accordance with the following table <Table 1>.
- Cable cross-sectional area 1.25 mm² to 2.00 mm²

<Table 1>

System configuration	For a single-refrigerant system		For a multi-refrigerant system
Transmission cable length	Less than 120 m	More than 120 m	Regardless of length
Facility example (for noise judgment)	Residence or independent store without noise	Building, clinic, hospital or communications station without noise supposedly generated from inverter equipment, private power generator, high-frequency medical equipment, radio-used communications equipment and so on	All facilities
Types of transmission cables	VCTF, VCTFK, CVV, CVS, VVR, VVF, VCT or shielding wire CVVS or CPEVS Shielding wire CVVS or CPEVS		

2. Remote controller cables

	MA Remote controller (PAR-20MAA)		ME Remote controller (PAR-F27MEA, PAC-SE51CRA)	
	Type	VCTF, VCTFK, CVV, CVS, VVR, VVF, VCT	10 m or shorter VCTF, VCTFK, CVV, CVS, VVR, VVF, VCT	If the length exceeds 10 m.
Wire Type	Number of conductors	2-conductor cable		M-NET transmission cable
	Wire diameter	0.3 ~ 1.25 mm ² (Note 1)	0.3 ~ 1.25 mm ² (Note 1) (0.75 ~ 1.25 mm ²) (Note 2)	
Total Length		Max. 200 m	Max. 10 m	If the length exceeds 10 m, keep the length within the maximum length of communications lines between indoor and outdoor units.

Note1 For work purposes, a wire diameter of 0.75 mm² is recommended.

Note2 If you are running the wires to the PAC-SE51CRA terminal block, use the wire diameter shown in ().

8.3. Electrical wiring diagram

■ GUF-50 · 100RDH3

- TM1, TM2, TM3 shown in dotted lines are field work.
- Be sure to connect the grounding wire.
- Breakers and controller switches should be provided by the customer.

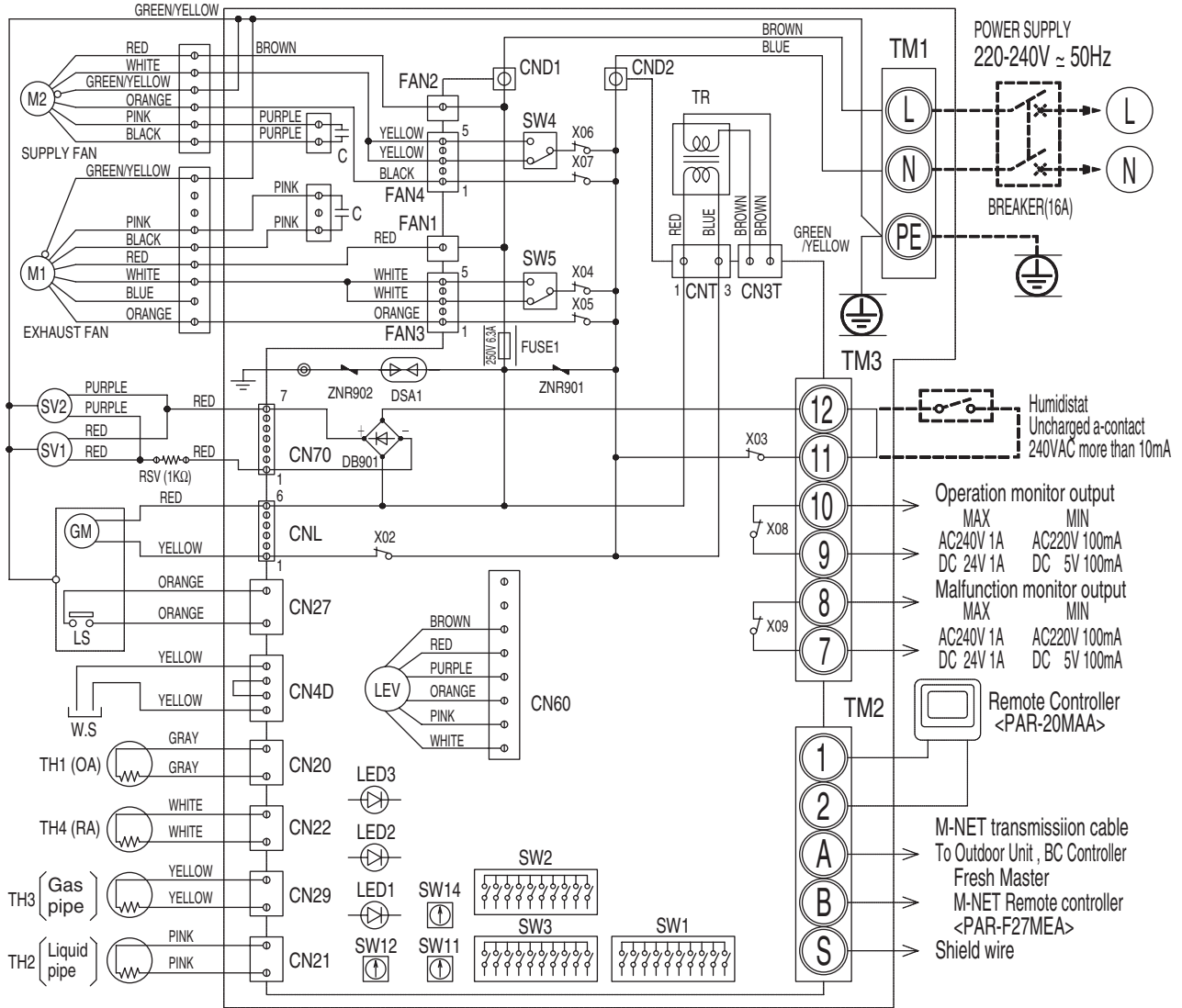

- NOTE
1. TM1, TM2, TM3 shown in dotted lines are field work.
 2. Be sure to connect the grounding wire.
 3. Breakers should be provided by the customer.
 4. MARK ○ : indicates terminal block, ⊙ : connector, ⊕ : board insertion connector or fastening connector of control board.

■ Warning
Before obtaining access to terminals, all supply circuits must be disconnected.

■ SYMBOL EXPLANATION

Symbol	Name	Symbol	Name	Symbol	Name
M1	Fan motor (exhaust)	TM1	Terminal block (power supply)	1, 2	Remote control terminal
M2	Fan motor (supply)	TM2	Terminal block (transmission)	A, B	M-NET transmission terminal
C	Capacitor	TM3	Terminal block (humidistat, monitor)	S	Shield
W.S	Water sensor	SW1	Switch (function selection)	CND1, CND2	Connector (power supply)
SV1	Solenoid valve (pressure regulator)	SW2	Switch (capacity code setting)	X02-X09	Relay
SV2	Solenoid valve (exhaust)	SW3	Switch (function selection)	TR	Transformer
TH1	Thermistor (outdoor air temp. detection)	SW4	Switch	GM	Damper motor
TH2	Thermistor (pipe temp. detection/liquid)	SW5	Switch	LS	Limit switch
TH3	Thermistor (pipe temp. detection/gas)	SW11	Switch (1st digit address set)	LED1	Power supply monitor
TH4	Thermistor (room air temp. detection)	SW12	Switch (2nd digit address set)	LED2	MA Remote controller Power supply monitor
LEV	Electronic linear expansion valve	SW14	Switch (branch NO. set)	LED3	M-NET Power supply monitor
RSV	Resistance(solenoid valve)				

■ GUF-50 · 100RD3

- TM1, TM2, TM3 shown in dotted lines are field work.
- Be sure to connect the grounding wire.
- Breakers and controller switches should be provided by the customer.

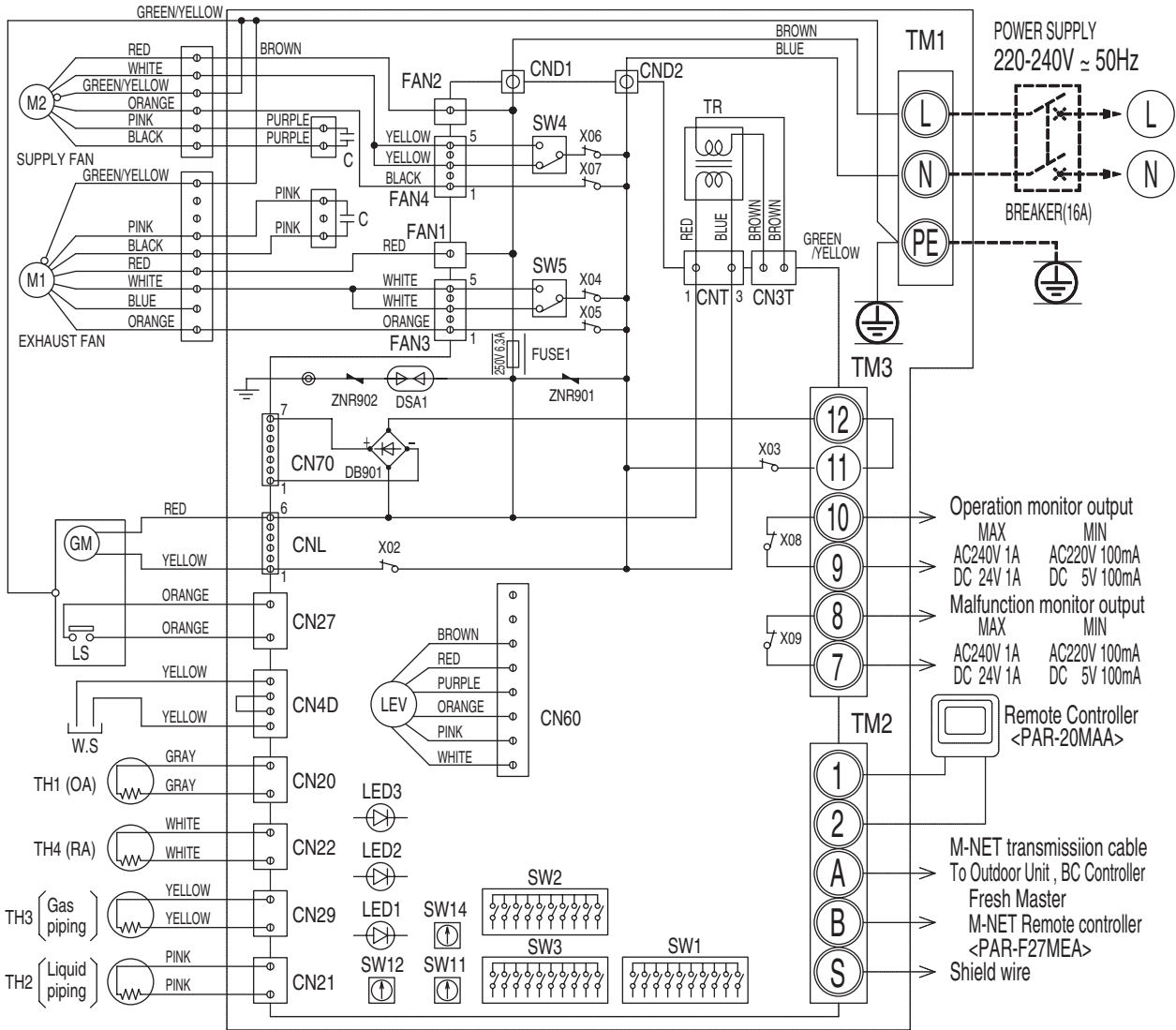

- NOTE
1. TM1, TM2, TM3 shown in dotted lines are field work.
 2. Be sure to connect the grounding wire.
 3. Breakers should be provided by the customer.
 4. MARK ○ : indicates terminal block, ⊙ : connector, ⊞ : board insertion connector or fastening connector of control board.

■ Warning
 Before obtaining access to terminals, all supply circuits must be disconnected.

■ SYMBOL EXPLANATION

Symbol	Name	Symbol	Name	Symbol	Name
M1	Fan motor (exhaust)	TM1	Terminal block (power supply)	1, 2	Remote control terminal
M2	Fan motor (supply)	TM2	Terminal block (transmission)	A, B	M-NET transmission terminal
C	Capacitor	TM3	Terminal block (humidistat, monitor)	S	Shield
W.S	Water sensor	SW1	Switch (function selection)	CND1, CND2	Connector (power supply)
TH1	Thermistor (outdoor air temp. detection)	SW2	Switch (capacity code setting)	X02-X09	Relay
TH2	Thermistor (pipe temp. detection/liquid)	SW3	Switch (function selection)	TR	Transformer
TH3	Thermistor (pipe temp. detection/gas)	SW4	Switch	GM	Damper motor
TH4	Thermistor (room air temp. detection)	SW5	Switch	LS	Limit switch
LEV	Electronic linear expansion valve	SW11	Switch (1st digit address set)	LED1	Power supply monitor
		SW12	Switch (2nd digit address set)	LED2	MA Remote controller Power supply monitor
		SW14	Switch (branch NO. set)	LED3	M-NET Power supply monitor

8.4. Power supply wiring

Power cable size: 1.5 mm² or more

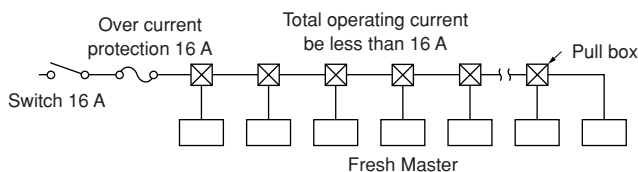

[Selecting non-fuse breaker (NF) or earth leakage breaker (NV)]

To select NF or NV instead of a combination of Class B fuse with switch, use the following:

- In the case of Class B fuse rated 15 A or 20 A,

NF model name (MITSUBISHI): NF30-CS (15 A) (20 A)

NV model name (MITSUBISHI): NV30-CA (15 A) (20 A)

Use an earth leakage breaker with a sensitivity of less than 30 mA 0.1 sec.

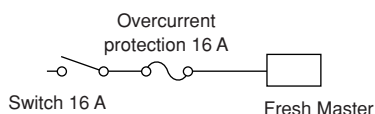

⚠ Caution:

Do not use anything other than the correct capacity breaker and fuse. Using fuse, wire or copper wire with too large capacity may cause a risk of malfunction or fire.

8.5. Connecting the Remote controller, the Fresh Master and outdoor transmission cables

(The Remote controller is optionally available.)

- Connect Fresh Master TM2 and outdoor unit TB3. (Non-polarized 2-wire)

The "S" on Fresh Master TM2 is a shielding wire connection. For specifications about the connecting cables, refer to the outdoor unit installation manual.

- Install the Remote controller following the manual supplied with the Remote controller.

[For using the ME Remote controller]

Connect the "A" and "B" on Fresh Master TM2 to the Remote controller. (Non-polarized 2-wire) Connect the Remote controller's transmission cable within 200 m. If the distance is more than 10 m, use a 1.25 mm² to 2.0 mm² cable.

[For using the MA Remote controller]

Connect the "1" and "2" on Fresh Master TM2 to the Remote controller. (Non-polarized 2-wire) Connect the Remote controller's transmission cable within 200 m.

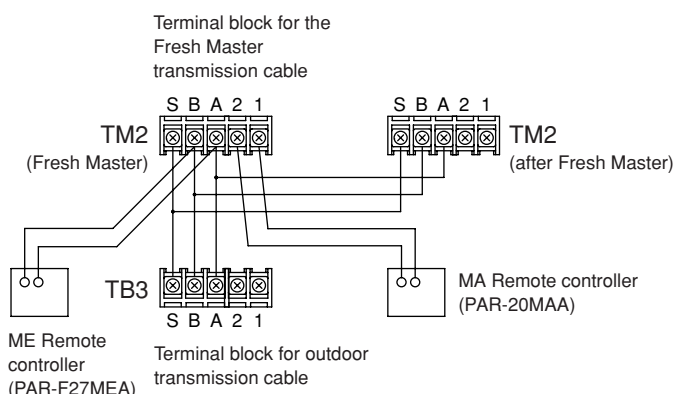

- 24 to 30 V DC between M1 and M2

Longest wiring length (L1+L2+L4 or L1+L3): less than 200 m

Longest wiring length (L2+L3+L4): less than 500 m

Length between the Fresh Master and the Remote controller (ℓ): within 10 m

Notes:

*1 Put the transmission cable earth via the outdoor unit's earth terminal (⊕) to the ground.

*2 If the Remote controller cable exceeds 10 m, use a 1.25 mm² to 2.0 mm² cable over the exceeded portion, and add that exceeded portion to within 200 m.

*3 The BC controller is required only for simultaneous cooling and heating series R2.

[Constraints on transmission cable]

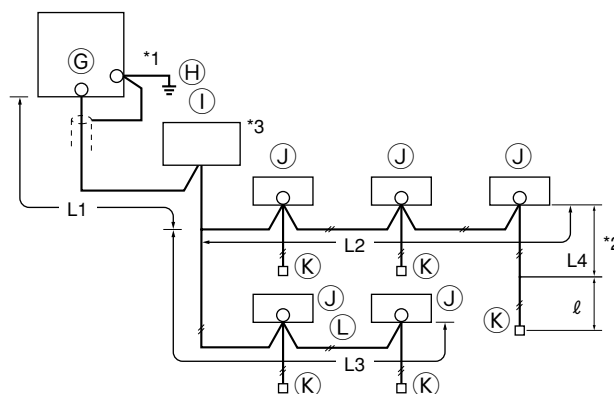

- Ⓒ Outdoor unit
- Ⓓ Earth
- Ⓔ BC controller
- Ⓕ Fresh Master
- Ⓖ Remote controller
- Ⓗ Non-polarized 2-wire

8.6. Connecting electrical connections

1. Remove the 4 screws to remove the control box cover.

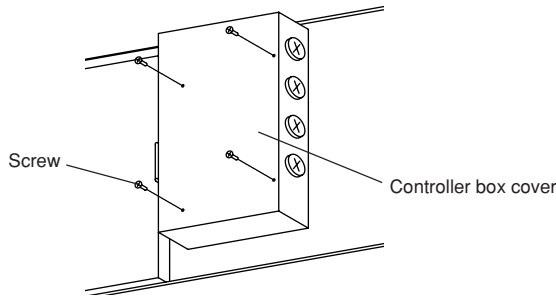

2. Install a PG connection or the like, then connect the power supply cable to the TM1 terminal block.

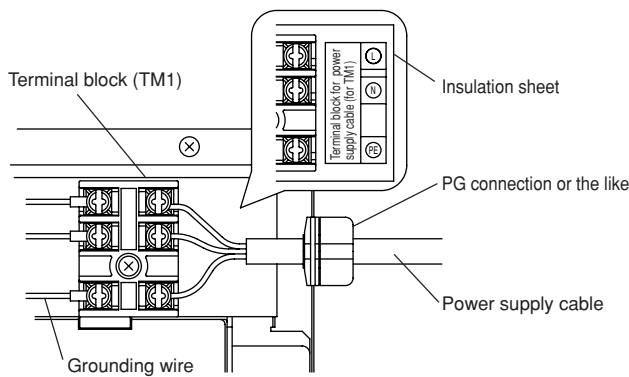

⚠ Caution:
Wire the power supply so that no tension is imparted. Otherwise disconnection, heating or fire may result.

3. Connect the transmission line to the TM2 terminal block as shown in the diagram.

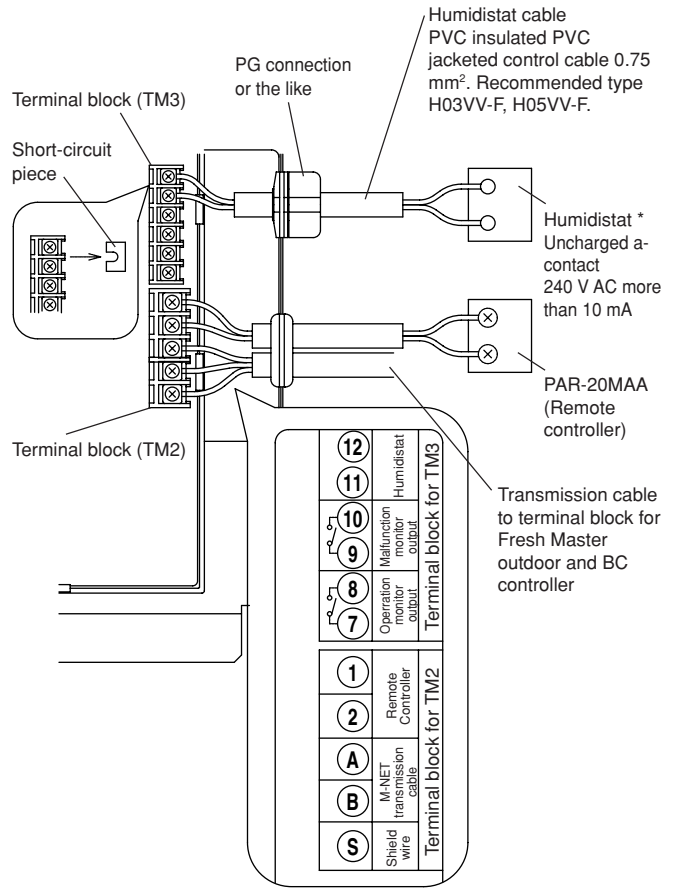

4. When connecting the humidistat input, remove the short-circuit piece from the TM3 terminal block as shown in the diagram, then install a PG connector and connect to the TM3 terminal block.

* The humidistat is the sensor designed specifically for the control of moisture environment.

The suitable model in this stage :

Uncharged a-contact turns on when atmospheric moisture content becomes less than your preset minimum allowable percentage.

9. Feature settings

⚠ Caution:

- * Always turn off the main power supply.
- * Remove the control box cover.

9.1. Address setting

(Determining the address depends on the own-site system. Please see to technical references, etc.)

Remove the control box cover.

Turn the address setting switch on the board using a Phillips screw-driver.

- The left side (SW12) shows the second digit and the right side (SW11) shows the first digit.
- The switch is set to 00 when factory shipped.
- Set the address between 1 and 50.

9.2. When using an R2 series external unit, setting for the branch No. is also required.

Turn the branch controller No. setting switch (SW14) on the board using a Phillips screwdriver.

- Set the refrigerant pipe of the external unit and the connected branch controller to the same number.
- The switch is set to 0 when factory shipped.

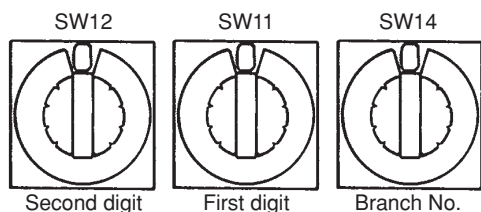

SW3---- GUF-50 · 100RDH3

	OFF	ON	
1	<input checked="" type="checkbox"/>	<input type="checkbox"/>	Synchronous air-conditioning switch (async when ON)
2	<input checked="" type="checkbox"/>	<input type="checkbox"/>	
3	<input checked="" type="checkbox"/>	<input type="checkbox"/>	Humidifier mode (OFF: humidifier; ON: heat save)
4	<input checked="" type="checkbox"/>	<input type="checkbox"/>	
5	<input type="checkbox"/>	<input checked="" type="checkbox"/>	Heater operation during synchronous operation/ stop temperature switch
6	<input checked="" type="checkbox"/>	<input type="checkbox"/>	
7	<input checked="" type="checkbox"/>	<input type="checkbox"/>	Exhaust fan operation when supply fan is stopped (exhaust fan also stopped when ON)
8	<input checked="" type="checkbox"/>	<input type="checkbox"/>	
9	<input checked="" type="checkbox"/>	<input type="checkbox"/>	Do not touch
10	<input checked="" type="checkbox"/>	<input type="checkbox"/>	

SW3---- GUF-50 · 100RD3

	OFF	ON	
1	<input checked="" type="checkbox"/>	<input type="checkbox"/>	Synchronous air-conditioning switch (async when ON)
2	<input checked="" type="checkbox"/>	<input type="checkbox"/>	
3	<input checked="" type="checkbox"/>	<input type="checkbox"/>	Do not touch
4	<input checked="" type="checkbox"/>	<input type="checkbox"/>	
5	<input checked="" type="checkbox"/>	<input type="checkbox"/>	Exhaust fan operation when supply fan is stopped (exhaust fan also stopped when ON)
6	<input checked="" type="checkbox"/>	<input type="checkbox"/>	
7	<input checked="" type="checkbox"/>	<input type="checkbox"/>	Do not touch
8	<input checked="" type="checkbox"/>	<input type="checkbox"/>	
9	<input checked="" type="checkbox"/>	<input type="checkbox"/>	Room temperature detected at main unit is decreased by 4°C when heating. (OFF: active; ON: inactive)
10	<input type="checkbox"/>	<input checked="" type="checkbox"/>	

9.3. Feature select switches (SW1, SW3, SW2)

* When shipped from the factory
Items concerning humidifying is for GUF-50 · 100RDH3 only.

SW1

	OFF	ON	
1	<input checked="" type="checkbox"/>	<input type="checkbox"/>	Fan test operation switch (test operation when ON)
2	<input checked="" type="checkbox"/>	<input type="checkbox"/>	
3	<input checked="" type="checkbox"/>	<input type="checkbox"/>	Filter maintenance display (displayed when ON)
4	<input checked="" type="checkbox"/>	<input type="checkbox"/>	
5	<input checked="" type="checkbox"/>	<input type="checkbox"/>	Filter maintenance time setting switch
6	<input checked="" type="checkbox"/>	<input type="checkbox"/>	
7	<input checked="" type="checkbox"/>	<input type="checkbox"/>	Do not touch
8	<input checked="" type="checkbox"/>	<input type="checkbox"/>	
9	<input checked="" type="checkbox"/>	<input type="checkbox"/>	Damper motor test operation (test operation when ON)
10	<input checked="" type="checkbox"/>	<input type="checkbox"/>	

SW2

	OFF	ON	
1	<input type="checkbox"/>	<input checked="" type="checkbox"/>	Do not touch
2	<input checked="" type="checkbox"/>	<input type="checkbox"/>	
3	<input type="checkbox"/>	<input checked="" type="checkbox"/>	Do not touch
4	<input type="checkbox"/>	<input checked="" type="checkbox"/>	
5	<input checked="" type="checkbox"/>	<input type="checkbox"/>	Do not touch
6	<input checked="" type="checkbox"/>	<input type="checkbox"/>	
7	<input checked="" type="checkbox"/>	<input type="checkbox"/>	Fan speed control method select switch 7: OFF, 8: ON fix to High speed. Both ONs fix to Low speed.
8	<input checked="" type="checkbox"/>	<input type="checkbox"/>	
9	<input checked="" type="checkbox"/>	<input type="checkbox"/>	Do not touch
10	<input checked="" type="checkbox"/>	<input type="checkbox"/>	

Notes:

- * The switches are vertical for explanation purposes.

9.3.1. Filter maintenance time setting

Set the filter maintenance display ON/OFF and time according to use.

Switch	OFF	ON	Maintenance time
SW1	2		Filter maintenance display ON
	2		Filter maintenance display OFF*
	3 4		1,500 hours
	3 4		3,000 hours*
	3 4		4,500 hours
	3 4		Unrestricted

When the accumulated operation time reaches the set time, indication for filter cleaning is notified to the Remote controller. After cleaning, press the filter button twice to reset the accumulated operation time.

9.3.2. Power-failure auto-recovery select (independent of Fresh Master)

Set the Fresh Master operation condition when power failure is recovered.

Switch	OFF	ON	Mode
SW1	9		Fresh Master stopped when power failure is recovered.*
	9		Fresh Master recovers to the prior state when power failure is recovered.

9.3.3. Power ON feature

Set whether to operate the Fresh Master or not when the main power is turned ON.

Switch	OFF	ON	Mode
SW1	10		Inactive: operates according to the SW1-9 setting*
	10		Active: operation starts with power ON

9.3.4. Indoor unit and synchronous setting

Setting to synchronize with the indoor unit.

Switch	OFF	ON	Mode
SW3	1		Synchronizing with the indoor unit*
	1		Asynchronous with the indoor unit. The Remote controller operation only.

9.3.5. Humidifier mode select (GUF-50 · 100RDH3 only)

Setting the humidifier mode.

Switch	OFF	ON	Mode
SW3	2		Standard humidifier mode*
	2		Heat save humidifier mode (see below)

Used when operating only the Fresh Master and the temperature during heating becomes too hot. The heating capability can be saved lower temperature than normal.

9.3.6. Heat operation stop temperature setting (GUF-50 · 100RDH3 only)

Stopping the heating operation when synchronous with the indoor unit. It becomes invalid when SW3-1 is ON.

Switch	OFF		Set outside temperature	ON		Set outside temperature
	3	4		3	4	
SW3	3		6°C	3		10°C*
	4			4		
	5			5		
	3		7°C	3		12°C
	4			4		
	5			5		
	3		8°C	3		14°C
	4			4		
	5			5		
	3		9°C	3		16°C
	4			4		
	5			5		

9.3.7. Exhaust fan operation setting

Setting the exhaust fan operation, although the supply fan will stop when defrosting during heating or when withdrawing the refrigerant.

Switch	OFF	ON	Mode
SW3	6		Exhaust fan in operation even when the supply fan is stopped*
	6		Exhaust fan is stopped when the supply fan is stopped

9.3.8. Automatic humidifier control setting (GUF-50 · 100RDH3 only)

Although the permeable-film humidifier is supplied with water for humidifying when heating, there is a feature to automatically stop the water supply depending on the outside temperature.

Switch	OFF	ON	Mode
SW3	8		Automatic humidifier control prohibited* Water is supplied to the permeable-film humidifier constantly when the heater is in operation.
	8		Automatic humidifier control permitted When the outside temperature is below 12°C during heating operation, supply water to the permeable-film humidifier.

9.3.9. Selecting the fan speed control method

This setting is used to select whether to operate according to the fan speed requested by the indoor unit, or to operate in high or low speed.

Switch	OFF	ON	Mode
SW2	7 8		Following the selected fan speed from controllers.*
	7 8		Following the selected fan speed from controllers.
	7 8		High fan speed mode (notch constantly on high)
	7 8		Low fan speed mode (notch constantly on low)

* When factory shipped.

9.3.10. Room temperature control (GUF-50 · 100RD3 only)

Room temperature detected at main unit is decreased by 4°C when heating.

Switch	OFF	ON	Mode
SW3	8		Effective*
	8		Ineffective

9.3.11. Room temperature sensor position (GUF-50 · 100RD3 only)

Switch	OFF	ON	Mode
SW3	9		Fresh Master's return air*
	9		Built in the Remote controller.

10. Test run

► Read the operation manual, too.

- After installing, piping and wiring the Fresh Master and outdoor units, make sure again that there is no refrigerant leakage, no slack on the power and transmission cables, or no polarity mistakes.
- Make sure using a 500 V DC megger that the resistance between the power terminal bed and ground is more than 2.0 MΩ. If less than 2.0 MΩ, do not operate the unit.

Warning:
Never measure the insulation resistance of the terminal block for transmission cables.

Caution:
When operating the Fresh Master for a test run, be sure there is no water leakage.

■ When operating the Fresh Master for a test run

- ① Turn ON the test run switches (1, 7, 8) of the function changeover switch (SW1).

Switch	OFF	ON	Mode
SW1	1		Power is delivered to the fans for air supply and exhaust, and they start operating.
	7		The damper motor is powered on, and the bypass ventilation is activated.
	8		The solenoid valve unit with a pressure regulator that supplies water to the solenoid valve unit with a pressure regulator for the humidifier is powered on, and water is supplied (GUF-50·100RDH3 only).

Notes:

- When the test run switches (1, 7, 8) are turned on, the Remote controller inspection code "0900" is displayed.
- The operating sound of the damper plate is generated when the test run switch 7 is turned on. However, it is not abnormal.

- ② Turn off the test run switches (1, 7, 8).

■ When operating the Fresh Master directly using the Remote controller (SW3-1 is ON)

Operational Procedure

- ① Turn ON power at least 12 hours before operation
- ② Press [TEST RUN] button twice → displaying "TEST RUN" on the screen
- ③ Press [Selecting operation] button → Check that wind is blowing out
- ④ Press [Selecting operation] button to change over to cooling (or heating) → Check that cool (or warm) air is blowing out
- ⑤ Press [Fan speed adjustment] button → Check that the wind speed is changed
- ⑥ → Check that the outdoor unit fan is operating
- ⑦ Press [ON/OFF] button to clear test run → Test run stops

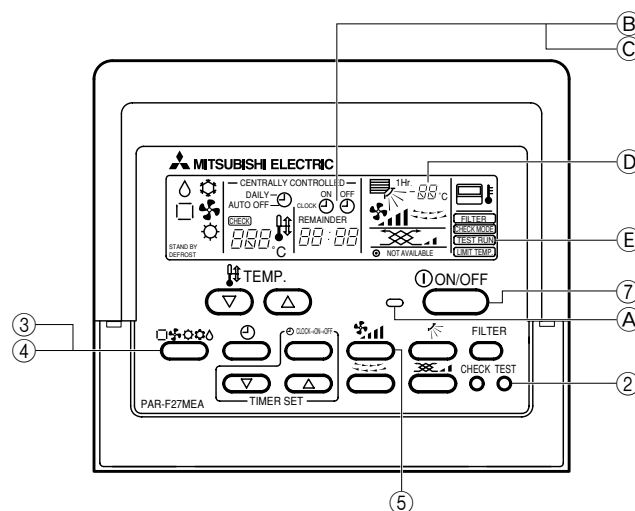

- ① Lighting in operation
- ② Displaying inspection code
- ③ Displaying remaining test run time
- ④ Displaying indoor unit's liquid pipe temperature
- ⑤ Displaying test run

Notes:

- It takes a while until warm air comes out when heating. When cooling, make sure that the display on the remote control shows "Cooling".
- The 2-hour-set timer is activated to automatically stop test run after two hours.

■ When operating the Fresh Master by synchronizing with the indoor unit

During test operation of the indoor unit, press the ventilation button to operate the Fresh Master simultaneously.

Check to make sure that the mode is the same as the indoor unit operation mode.

Notes:

- If the Remote controller shows an inspection code or does not operate normally, refer to the outdoor unit installation manual.
- The 2-hour-set timer is activated to automatically stop test run after two hours.
- The Remote controller displays the remaining test run time on the time display section during test run.
- The Remote controller displays the temperature of the indoor unit's liquid pipe on the temperature display section during test run.
- Depending on the model, the Remote controller displays "This function is not available" when pressing the [Up/down airflow selection] button. This is not a malfunction.

■ In case of abnormality during a test-run operation

If the unit fails to operate normally, check the phenomena and causes listed below, and correct the problem. (The phenomena listed below are applicable to the test-run mode.)

Phenomenon	Cause
(1) No Remote controller display appears at all.	• The source power supply is not turned on.
(2) No Remote controller display appears at all.	• Wiring error, short-circuit or contact failure of transmission line
(3) Inspection code "6600" flashes.	• Error in setting the indoor unit address There are duplicate address settings, meaning there are indoor units with the same address.
(4) Inspection code "7107" flashes.	• Error in setting the branch exit number.
(5) Inspection code "7106" flashes.	• The Remote controller was connected with the SW3-1 OFF.

11. Troubleshooting

See below for possible remedies when there is an error during test operation and [Check] followed by a 4-digit number is displayed on the remote controller.

Error code	Error content	Cause	Remedy
0900	Test run	<ul style="list-style-type: none"> Is the test operation SW of either the fan, humidifier solenoid valve or bypass damper turned ON? 	<ul style="list-style-type: none"> Set the test operation SW (SW1-1, 7, 8) to OFF.
2600	Drain error	<ul style="list-style-type: none"> Drain water is not properly discharged. Is there a leak from the permeable-film humidifier? Is there a leak from the permeable-film humidifier? When no problem is discovered after checking the above items. 	<ul style="list-style-type: none"> The body must be levelly installed. The drain pipe must be installed with gradient of more than 1/100. Fix the water leak. Replace the permeable-film humidifier. Replace the PCB (printed circuit board).
2601	Disconnected water sensor connector	<ul style="list-style-type: none"> Is the CN4D connector firmly connected? Is the relay connector between the PCB and water sensor firmly connected? When no problem is discovered after checking the above item. 	<ul style="list-style-type: none"> Firmly connect the connector. Firmly connect the connector. Replace the PCB (printer circuit board).
3602	Damper motor error	<ul style="list-style-type: none"> Is the CNL connector firmly connected? Is the connector of the damper motor section firmly connected? Does the damper operate when the damper motor is running? When no problem is discovered after checking the above items. 	<ul style="list-style-type: none"> Firmly connect the connector. Firmly connect the connector. Replace the damper motor if not working. Replace the PCB (printed circuit board).
4116	Fan motor error	<ul style="list-style-type: none"> The motor continues to run when the operation is stopped. 	<ul style="list-style-type: none"> Replace the PCB (printed circuit board).
5101	Indoor temperature sensor error	<ul style="list-style-type: none"> Are the connectors of each thermister firmly connected? 	<ul style="list-style-type: none"> Firmly connect each connector.
5102	Liquid pipe temperature sensor error	<ul style="list-style-type: none"> Is each relay connector firmly connected? 	<ul style="list-style-type: none"> Firmly connect each connector.
5103	Gas pipe temperature sensor error	<ul style="list-style-type: none"> When no problem is discovered after checking the above item. 	<ul style="list-style-type: none"> Replace the PCB (printed circuit board).
5104	Outdoor temperature sensor error		
H0	Booting system	<ul style="list-style-type: none"> Has 10 minutes passed since system boot-up? Has group registration been made? Has the Fresh Master address been changed? When no problem is discovered after checking the above items. 	<ul style="list-style-type: none"> After system boot-up, HO may flash for a maximum of 10 minutes. However, this is not a malfunction. Conduct group registration. If there is a master system controller such as the central controller, use the controller to conduct group registration. If the Fresh Master main unit address has been changed, conduct the group registration again. If HO continues to flash for more than 10 minutes after reregistering the group and rebooting, replace the PCB (printed circuit board).
–	Unable to register.	<ul style="list-style-type: none"> The Fresh Master which is linked with air conditioner, cannot be group registered other than the interlock setting with the Remote controller. 	<ul style="list-style-type: none"> Change the setting of the SW3-1 switch and reset the registration or register it interlocked.
–	Operation display comes up with the Remote controller, however it turns off immediately.	<ul style="list-style-type: none"> Main power hasn't supplied to the Fresh Master. 	<ul style="list-style-type: none"> Supply Main Power.

