

MITSUBISHI ELECTRIC MITSUBISHI ELECTRIC MULTI AIR CONDITIONERS OPTIONAL PARTS

CMY-Y100VBK2, Y200VBK2, Y300VBK2

Outdoor Twinning Kit Installation Manual

For safe and correct use, please read this installation manual thoroughly before installation. For your safety, follow the instructions with **WARNING** and **CAUTION** symbols.

Safety Precautions

- Before installing the unit, make sure you read all the "Safety precautions".
- These precautions provide very important points regarding safety. Make sure you follow them.
- The following symbols are intended to alert the presence of danger in case of miss-operation.

WARNING	This symbol indicates that failure to follow the instructions exactly as stated poses the risk of serious injury or death.
CAUTION	This symbol indicates that failure to follow the instructions exactly as stated poses the risk of injury or damage to the unit and other property.

WARNING

Ask the dealer or an authorized technician to install the unit.

- Improper installation may result in problems such as gas leakage.

Do not modify the unit in any way. Ask your dealer to repair the air conditioner.

- Improper installation by the user may result in water leakage, electric shock, or fire.

If refrigerant gas leaks during installation work, ventilate the room.

- If the refrigerant gas comes into contact with a flame, poisonous gases will be released.

Install the unit according to this Installation Manual.

- Select appropriate twinning types and sizes of connecting pipes. If inappropriate types or sizes are connected, the air conditioning system cannot deliver the expected performance.

When installing or moving the unit, make sure that the specified refrigerant (R410A only) is charged into the refrigerant circuit.

- Any presence of foreign substance or even air can cause abnormal pressure rise or explosion.

After the installation is completed, make sure that the refrigerant gas is not leaking.

- If the refrigerant gas leaks into the room, and it is exposed to a fan heater, space heater, kitchen range, or some other heat source, it may generate a noxious gas.

CAUTION

Safely dispose of the packing materials.

- Tear up and throw away any plastic packaging bags so that children will not play with them. If children play with a plastic bag which has not been torn apart, they run the risk of suffocation.

Do not touch the refrigerant pipes during and immediately after operation.

- During and immediately after the operation, the parts of the refrigerant circuit including the refrigerant piping or the compressor may be hot or cold, depending on the condition of the flowing refrigerant. To prevent the risk of frostbite or burns, do not touch these parts with bare hands.

* For general instructions on the installation of an outdoor unit, follow the Installation Manual for the outdoor unit.

1. Confirming the Supplied Parts

The twinning kit box (CMY-Y100VBK2, CMY-Y200VBK2, and CMY-Y300VBK2) contains the following twinning and accessory piping parts. Make sure that the kit contains all of these parts.

After checking, prepare the twinning kit by connecting the twinning pipes b, c, and d to the twinning pipe a.

*Always use the twinning pipes included in the kit when preparing the twinning kit.

Depending on the model type, the size of the field piping may be different from the pipe size of the twinning kit. In such a case, connect the following accessory piping parts to the kit.

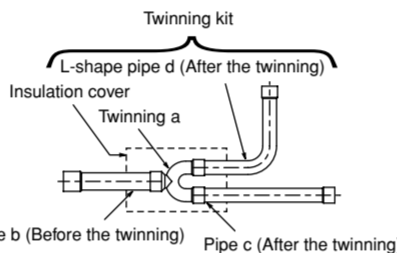

(1) Twinning pipes

Model	Section	Label	Twinning a	Pipe b (Before the twinning)	Pipe c (After the twinning)	L-shape pipe d (After the twinning)	Insulation cover	Instruction
CMY-Y100VBK2	Liquid	A	15.88×12.7×12.7	OD15.88-ID15.88 L83	OD12.7-ID12.7 L128	OD12.7-ID12.7	Small	1 (This sheet)
	Gas	D	28.58×25.4×25.4	OD28.58-ID28.58 L342	OD25.4-ID22.2 L190	OD25.4-ID22.2	Large	
CMY-Y200VBK2	Liquid	C	19.05×15.88×15.88	OD19.05-ID19.05 L85	OD15.88-ID15.88 L123	OD15.88-ID15.88	Small	
	Gas	B	31.75×28.58×28.58	OD31.75-ID34.93 L337	OD28.58-ID28.58 L192	OD28.58-ID28.58	Large	
CMY-Y300VBK2	Liquid Second row	A (Red)	15.88×12.7×12.7	OD15.88-ID19.05 L85	OD12.7-ID12.7 L128	OD12.7-ID12.7	Small	
	Liquid First row	C (Red)	19.05×15.88×15.88	OD19.05-ID19.05 L85	OD15.88-ID19.05 L125	OD15.88-ID15.88	Small	
	Gas Second row	D (Red)	28.58×25.4×25.4	OD28.58-ID34.93 L337	OD25.4-ID28.58 L192	OD25.4-ID28.58	Large	
	Gas First row	B (Red)	31.75×28.58×28.58	OD31.75-ID38.1 L339	OD28.58-ID34.93 L187	OD28.58-ID28.58	Large	

PUHY-P950 – P1250

Set model	PUHY-P950	PUHY-P1000	PUHY-P1050	PUHY-P1100	PUHY-P1150	PUHY-P1200	PUHY-P1250
Set Unit	Unit 1	PUHY-P400	PUHY-P400	PUHY-P400	PUHY-P400	PUHY-P450	PUHY-P450
	Unit 2	PUHY-P300	PUHY-P300	PUHY-P350	PUHY-P350	PUHY-P400	PUHY-P450
	Unit 3	PUHY-P250	PUHY-P300	PUHY-P300	PUHY-P350	PUHY-P350	PUHY-P350
Twinning Type CMY-Y300VBK2							
Indoor – Twinning 2	Liquid	a	ø19.05		ø41.28 (*)		
	Gas	b	ø34.93		ø41.28 (*)		
Twinning 1 – Twinning 2	Liquid	c	ø19.05		ø34.93		
	Gas	d	ø34.93		ø34.93		

PUHY-EP700 – EP900

Set model	PUHY-EP700	PUHY-EP750	PUHY-EP800	PUHY-EP850	PUHY-EP900
Set Unit	Unit 1	PUHY-EP300	PUHY-EP300	PUHY-EP300	PUHY-EP300
	Unit 2	PUHY-EP200	PUHY-EP200	PUHY-EP300	PUHY-EP300
	Unit 3	PUHY-EP200	PUHY-EP200	PUHY-EP200	PUHY-EP250
Outdoor Twinning Kit (optional parts) CMY-Y300VBK2					
Indoor unit - Twinning pipe 2	Liquid	a	ø19.05		ø41.28
	Gas	b	ø34.93		ø41.28
Twinning pipe 1 - Twinning pipe 2	Liquid	c	ø19.05		ø34.93
	Gas	d	ø34.93		ø34.93

Twinning pipe - Outdoor unit	Unit model	Liquid	Gas
	P250	e or g or i	f or h or j
P300	ø9.52 (*)	ø22.2	
P350	ø12.7 (*)	ø22.2	
P400	ø15.88	ø28.58	
P450	ø15.88	ø28.58	
EP200	ø9.52	ø19.05	
EP300	ø12.7	ø22.2	

(3) The angle of tilt of the twinning pipe

The angle of tilt of the twinning pipe should be within ±15° with the ground. Tilting the twinning pipe more than specified will cause damage to the unit.

Note: See the following drawing for the fitting position of the twinning pipe.

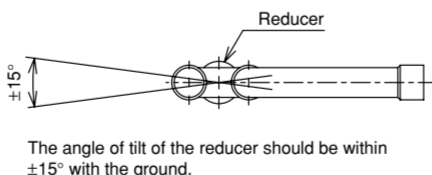

(4) The length of the straight part of the pipe before the twinning

For the twinning kit, always use the accessory piping parts. The length of the straight part of pipe connected in front of the twinning pipe must be 500 mm (19 inch) or longer. (Connect the field piping so that the length of the straight part of pipe connected in front of the twinning pipe can be 500 mm (19 inch) or longer.)

If the length is less than 500 mm (19 inch), it will cause damage to the unit.

(5) The piping connection

When connecting the twinning kit to the outdoor unit, note the following:

- If the length of piping from the twinning kit to the outdoor unit is more than 2 m (6 ft), install a trap within 2 m (6 ft) from the outdoor unit.

The height of the trap must be 200 mm (7 inch) or higher.

<2 m (6 ft) or less>

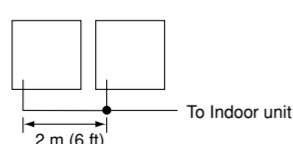

<More than 2 m (6 ft)>

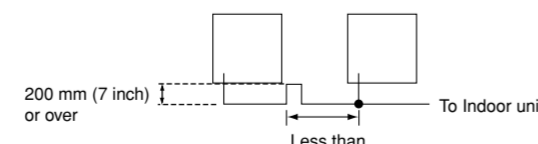

- When installing the twinning kit in a higher position than the outdoor unit base, make sure that the twinning kit is installed in a position lower than 200 mm (7 inch) from the outdoor unit base.

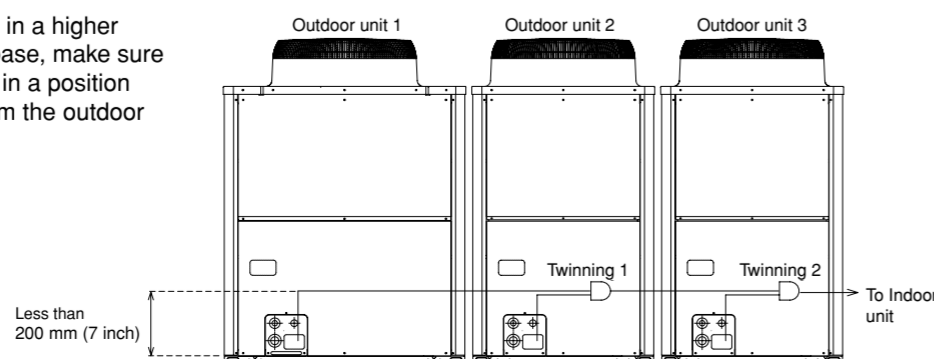

(2) Accessory piping parts

Model	Section	Supplied pipe			
		Liquid	Gas	Gas	Gas
CMY-Y100VBK2	Liquid	OD12.7-ID9.52 (2)	OD15.88-ID12.7		
	Gas	OD22.2-ID28.58	OD22.2-ID19.05 (2)		
CMY-Y200VBK2	Liquid	OD15.88-ID12.7 (2)			
	Gas	OD34.93-ID41.28			
CMY-Y300VBK2	Liquid	OD12.7-ID9.52	OD12.7-ID15.88 (2)	OD15.88-ID9.52	OD15.88-ID12.7
	Gas	OD28.58-ID22.2 (3)	OD38.1-ID41.28 (1)	OD28.58-ID19.05 (2)	OD38.1-ID34.93

(3) Field supplied parts

- Field supplied parts that do not come with the twinning kit
- Heat-resistant insulation material (for field piping)
- Insulation cover fixing tape

2. Selecting the Size of the Refrigerant Pipe and How to Use the Twinning Kit

(1) PUHY-P500 – P900, EP400 – EP650

(Outdoor unit x 2)

- Prepare the pipe to be connected in the field.
- Select the pipe size for each part from the table below. A (*) mark after a pipe size indicates that the specified pipe size in the following table can be obtained by connecting the accessory piping to the twinning kit.
- Cut the pipe with a pipe cutter and remove the burr. Connect the pipe after removing any dust or foreign matter.

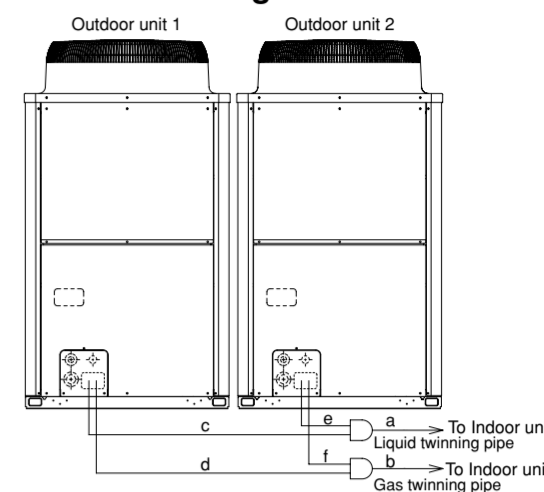

PUHY-P500 – P900

Set model	PUHY-P500	PUHY-P550	PUHY-P600	PUHY-P650	PUHY-P700	PUHY-P750	PUHY-P800	PUHY-P850	PUHY-P900
Set Unit	Unit 1	PUHY-P250	PUHY-P300	PUHY-P350	PUHY-P350	PUHY-P400	PUHY-P450	PUHY-P450	PUHY-P450
	Unit 2	PUHY-P250	PUHY-P250	PUHY-P300	PUHY-P350	PUHY-P350	PUHY-P350	PUHY-P400	PUHY-P450
Twinning Type CMY-Y100VBK2									
Indoor – Twinning	Liquid	a	ø15.88		ø19.05		ø41.28 (*)		
	Gas	b	ø28.58		ø34.93		ø41.28 (*)		

PUHY-EP400 – EP650

Set model	PUHY-EP400	PUHY-EP450	PUHY-EP500	PUHY-EP550	PUHY-EP600	PUHY-EP650
Set Unit	Outdoor unit 1	PUHY-EP200	PUHY-EP250	PUHY-EP300	PUHY-EP300	PUHY-EP300
	Outdoor unit 2	PUHY-EP200	PUHY-EP200	PUHY-EP200	PUHY-EP250	PUHY-EP300
Outdoor Twinning Kit (optional parts) CMY-Y100VBK2						
Indoor unit - Twinning pipe	Liquid	a	ø15.88		ø28.58	
	Gas	b	ø28.58		ø28.58	

Twinning pipe - Outdoor unit	Unit model	Liquid	Gas
	P250	c or e	d or f
P300	ø9.52 (*)	ø22.2	
P350	ø12.7 (*)	ø22.2	
P400	ø15.88	ø28.58	
P450	ø15.88	ø28.58	
EP200	ø9.52	ø19.05	
EP300	ø12.7	ø22.2	

(2) PUHY-P950 – P1250, EP700 – EP900

(Outdoor unit x 3)

- Prepare the pipe to be connected in the field.
- Select the pipe size for each part from the table below. A (*) mark after a pipe size indicates that the specified pipe size in the following table can be obtained by connecting the accessory piping to the twinning kit.
- Cut the pipe with a pipe cutter and remove the burr. Connect the pipe after removing any dust or foreign matter.

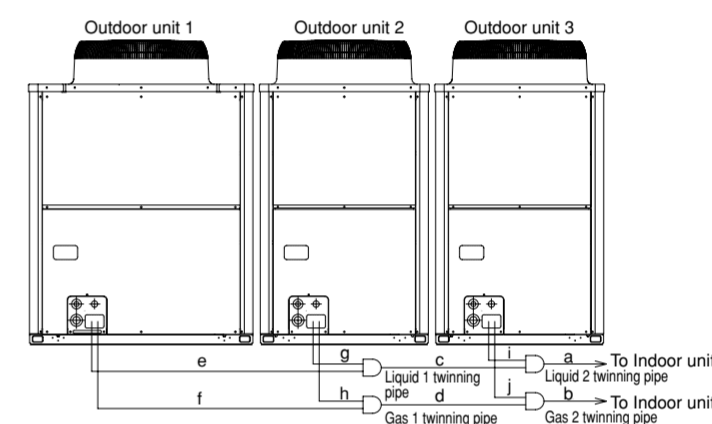

3. Example of a Pipe Connection

See the following drawing for connecting the pipes between the outdoor units.

<For 2 outdoor units>

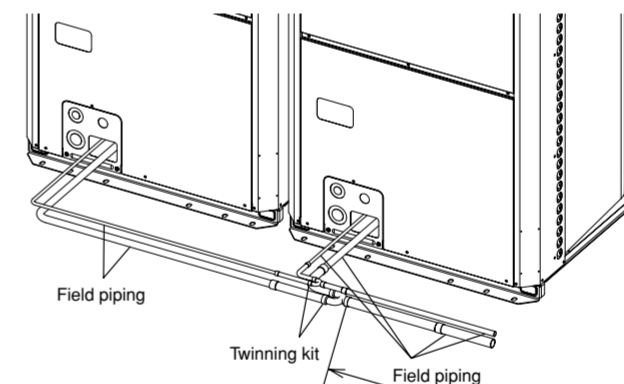

<For 3 outdoor units>

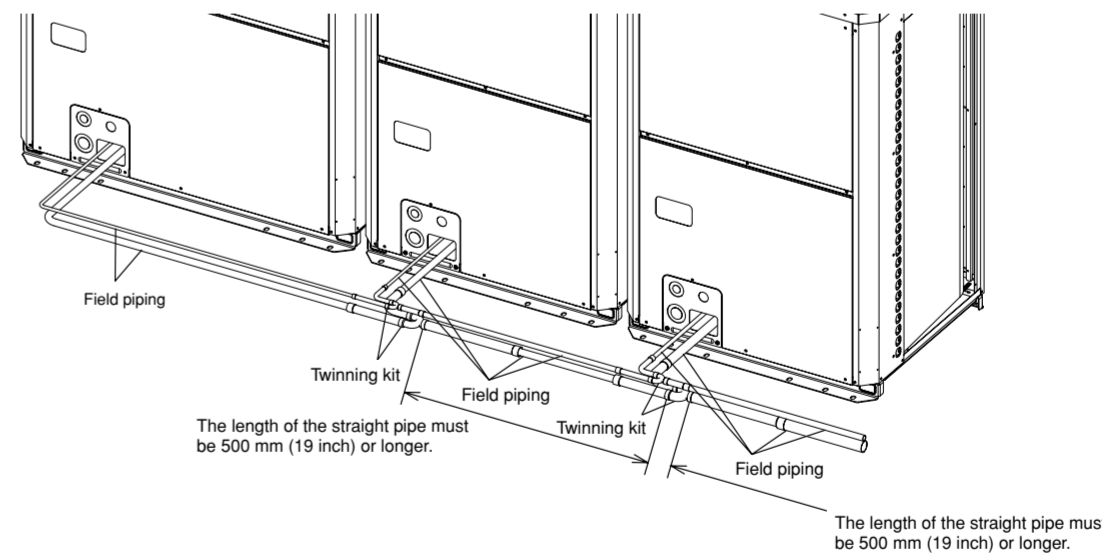

4. Installing the Insulation Cover

After brazing the pipes and the twinning kit, insulate the twinning kit with the insulation cover.

Add insulation materials on all the refrigerant piping, including the field piping. Make sure to insulate the pipes for liquid and gas separately. When using commercially available insulation material, make sure to use heat-resistant insulation material with heat-resistant temperature of 120 °C or higher.

Align the edges of the insulation cover and the heat-resistant insulation material so that there will be no gap. Seal also the periphery and centre of the twinning part with a tape (field supply).

