

7-2. OUTDOOR TWINNING KIT

For PURY-(E)P-YSHM-A, following optional Outdoor Twinning Kit is needed to use to combine to refrigerant flows of its PURY-(E)P-YHM-A. Details of selecting the proper kit should be referred to the System Design Section.

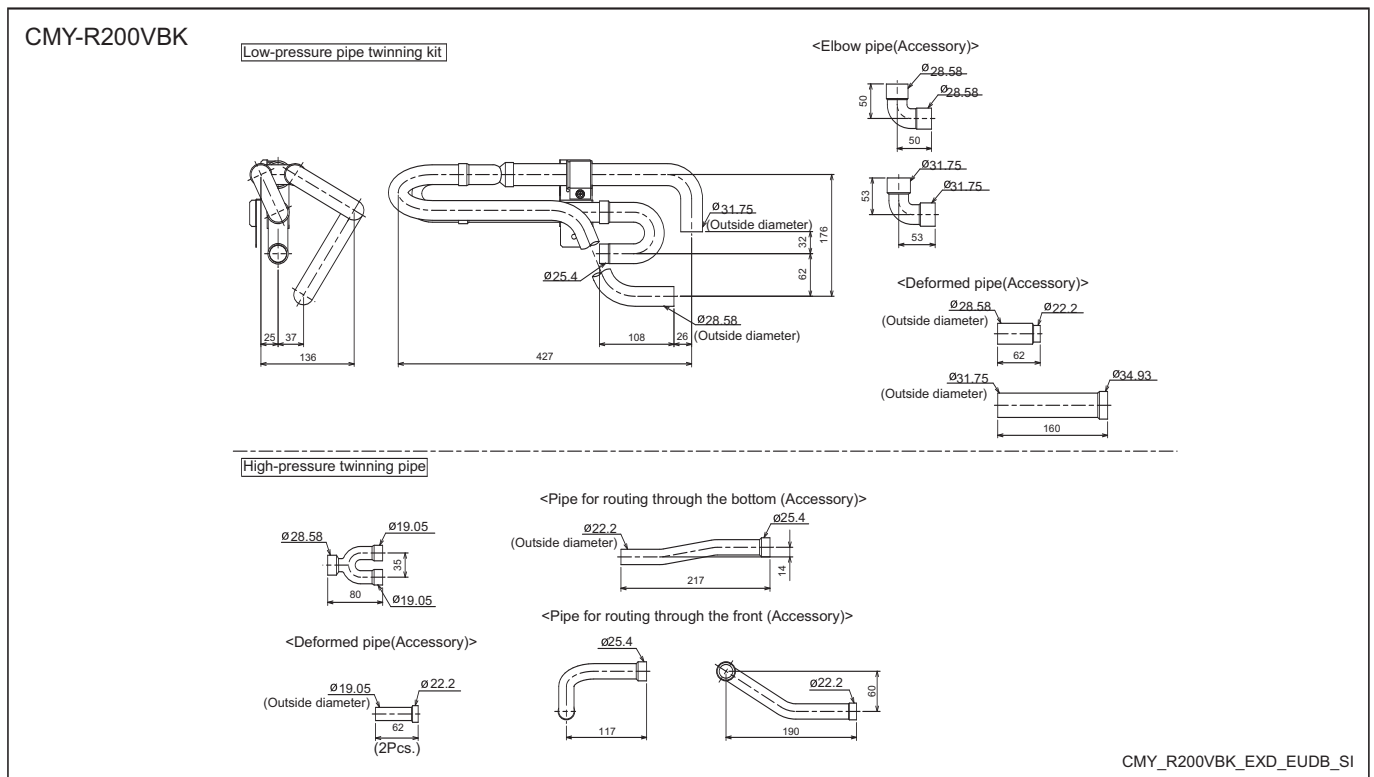

Note 1. Reference the attitude angle of the branch pipe below the fig.

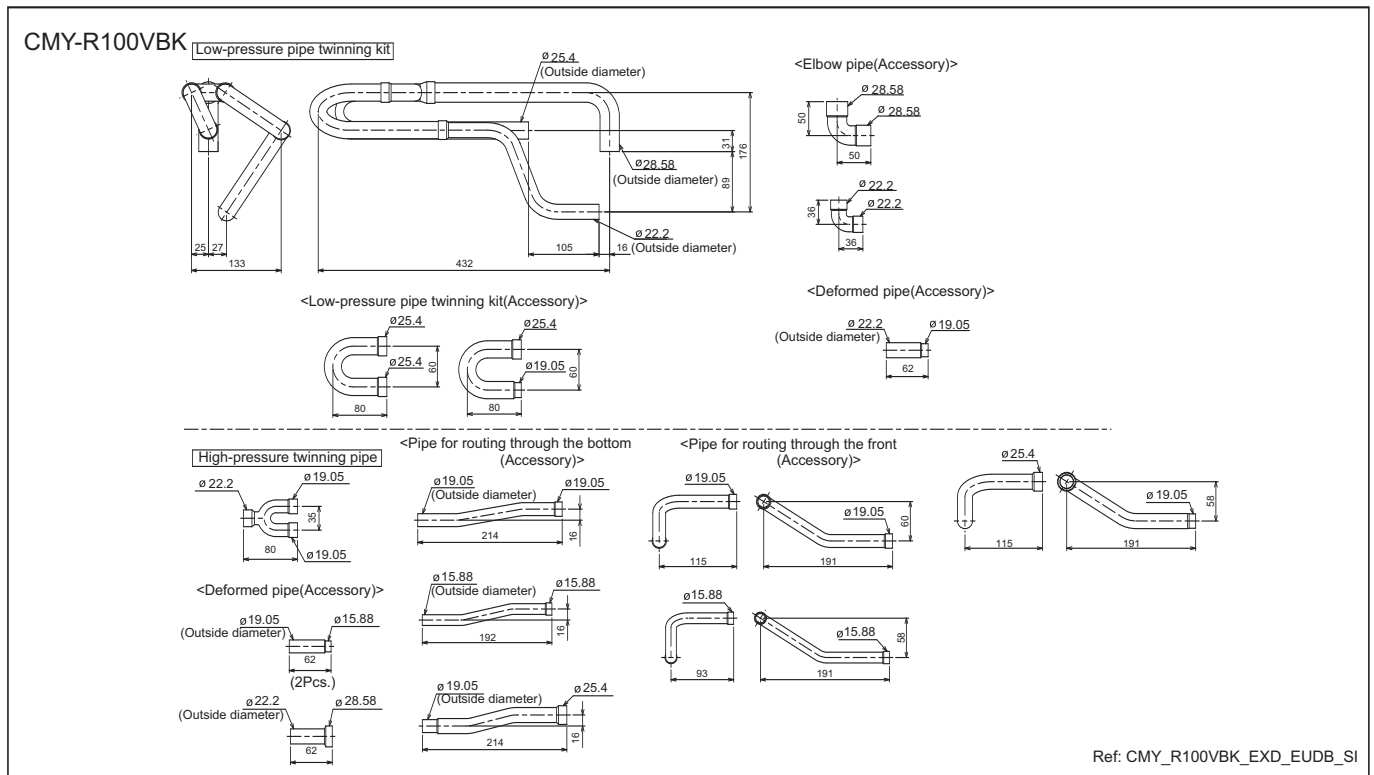
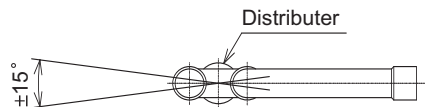

The angle of the branch pipe for high pressure is within $\pm 15^\circ$ against the ground.

2. Use the attached pipe to braze the port-opening of the distributor.
3. Pipe diameter is indicated by inside diameter.